

MODEL:	REV:	CHANGE LIST:	PAGE	FROM	TO
Z12 MB	1A	FIRST RELEASE : ECN NO. E200302-3095	1	1A	
	1B	MODIFY BOM : ECN NO. E200303-0277 PAGE05 : R495 CHANGE TO 127 ohm 1% PAGE06 : C604 & C654 CHANGE TO 220uF / 2.5V PAGE18 : D4 CHANGE TO CH715F PAGE26 : D35 DON'T STUFF PAGE33 : P06 CHANGE TO MAX1907AETL , PQ15 & PQ23 CHANGE TO FDB7045L , PC46 CHANGE TO 220pF PAGE36 : PUL3 CHANGE TO LM358AM	2	1A	
			3	3B	
			4	3A	
			5	1B	
			6	2A	
	1C	MODIFY BOM : ECN NO. E200303-2680 PAGE03 : Q40 CHANGE FOOTPRINT FOR SMT ISSUE PAGE06 : SOLVE FOR I2C BUS CAN'T READ DATA PAGE07 : C560 CHANGE FOOTPRINT FOR ASSEMBLY ISSUE PAGE08 : SOLVE FOR PCIRST SIGNAL NOT GOOD ISSUE PAGE09 : STUFF R634 FOR LAN WORKING PAGE10 : DDR ADDRESS LINE CHANGE & ADD EMI SOLUTION PAGE12 : SOLVE FOR I2C BUS CAN'T READING PAGE14 : U10 CHANGE TO CH7011A-T & CHANGE Q86,Q87 FOR SMBUS READING PAGE15 : SOLVE FOR LCD BACKLIGHT OFF ISSUE PAGE16 : UPDATE 4 IN 1 BOARD'S ALLOCATION HOLE SIZE PAGE18 : SOLVE FOR 4 IN 1 CARD READER MODULE READING SIGNAL PAGE19 : CHANGE LCD CONNECTOR FOOTPRINT FOR SMT ISSUE PAGE21 : ADD Q88 Q89 PAGE23 : ADD EMI SOLUTION PAGE24 : SOLVE FOR AUDIO QUALITY PAGE25 : ADD EMI SOLUTION & SOLVE FOR AUDIO QUALITY PAGE28 : SOLVE FOR USB2.0 ISSUE PAGE27 : CHANGE Q23 FOOTPRINT FOR SMT ISSUE PAGE29 : ADD EMI SOLUTION PAGE30 : ADD EMI SOLUTION PAGE32 : PQ6 CHANGE TO SI4810DY	7	1C	
			8	3B	
			9	3D	
			10	1C	
			11	1A	
			12	3C	
			13	3B	
			14	3B	
			15	3A	
			16	3A	
			17	3B	
			18	3B	
2A	MODIFY BOM : ECN NO. E200303-3536 PAGE06 : ADD R480 FOR TV-OUT PAGE21 : DON'T STUFF R510 FOR MINI PCI LAN CARD DON'T WORK PAGE27 : DON'T STUFF R150 FOR PWROK SIGNAL QUALITY	19	3D		
3A	MODIFY BOM : ECN NO. E200304-2184 PAGE03 : SOLVE LEAKAGE CURRENT ISSUE (Q40) PAGE04 : CHANGE FOOTPRINT FOR SMT ISSUE PAGE09 : CHANGE R460 FOR USB2.0 EYE DIAGRAM PAGE12 : ADD CLK BYPASS CAPACITOR FOR SIGNAL QUALITY PAGE14 : SOLVE FOR TV-OUT NOT GOOD ISSUE PAGE15 : ADD ACER'S REQUEST (HOT-KEY FOR BACKLIGHT) PAGE16 : ADD FINGER FOR ASSEMBLY ISSUE PAGE19 : SOLVE LEAKAGE CURRENT ISSUE (Q57) PAGE23 : CHANGE PART FOR ASSEMBLY ISSUE PAGE24 : SOLVE AUDIO NOISE & VOLUME ISSUE PAGE25 : SOLVE AUDIO NOISE ISSUE PAGE26 : CHANGE PART BY PURCHASE DEPT REQUEST PAGE27 : SOLVE LEAKAGE CURRENT ISSUE (Q23) PAGE28 : CONNECT USB HUB OVER CURRENT SIGNAL 1&2 TOGETHER PAGE29 : DELETE UNUSED NET PAGE31 : CHANGE PART FOR ASSEMBLY ISSUE	20	3B		
		21	3D		
		22	3B		
		23	3A		
		24	3B		
		25	3B		
		26	3A		
		27	3B		
		28	3D	3E	
		29	3B		
		3B	MODIFY BOM : ECN NO. E200305-1836 & E200305-2668 & E200306-0261 PAGE03 : DELETE ITP & SOLVE THERMAL SIGNAL MIXER PAGE08 : ENHANCE PCIRST SIGNAL QUALITY PAGE12 : ADD SUSC# FOR CLOCK POWERDOWN PAGE13 : SOLVE FOR ACER'S LCD MONITOR 1280x1024 NO DISPLAY ISSUE PAGE14 : SOLVE FOR VIEW SONIC'S MONITOR DISPLAY NO GOOD ISSUE PAGE17 : ENHANCE IDE RST SIGNAL PAGE18 : IMPROVE ICH_PME# SIGNAL PAGE19 : PREVENT SUPPEND LEAKAGE CURRENT ISSUE PAGE20 : IMPROVE ICH_PME# SIGNAL PAGE21 : IMPROVE ICH_PME# SIGNAL PAGE22 : SOLVE WAKE UP ON LAN ISSUE PAGE24 : SOLVE MIC SMALL VOLUME ISSUE PAGE25 : SOLVE PCMCIA DOS TEST NO SOUND ISSUE PAGE27 : SOLVE WAKE UP ON LAN ISSUE PAGE29 : PREVENT THERMAL SIGNAL UNPROBABLY WORK ISSUE PAGE35 : PREVENT DTC144EUA TRANSISTOR BAD CAUSE HDD NO POWER & REBOOT FAIL ISSUE	30	1C
31	3A				
32	1C				
33	1B				
34	1A				
35	3B				
36	1B				
37	1A				
3C	MODIFY BOM : ECN NO. E200306-1724 PAGE12 : MODIFY R244 TO 22 OHM 1% FOR USB CLOCK TIMEING ISSUE				
3D	PAGE09 : MODIFY ICH4 USB port 4 to Bluetooth PAGE19 : MODIFY 4IN1 USB port PAGE21 : MODIFY MDC USB port PAGE28 : MODIFY HUB USB port				
3E	PAGE28 : MODIFY HUB UPSTREAM PULL HIGH POWER				



PROJECT : Z12
Quanta Computer Inc.

PROJECT : Z12

MB ASSY'S P/N : 31Z12MB0007

APPROVE BY: LAWRENCE CHAO

PROJECT LEADER: JIM HSU

DRAWING BY: JACKY CHENG

DOCUMENT NO: 204

REV E3E

DATE : 2003/07/25

COVER SHEET 1 OF 1

Dr-Bios.com

ZI2 BLOCK DIAGRAM

CENTRINO

	PIRQ#	REQ#/GNT#	IDSEL
VGA	X	X	X
CARDBUS	C, (B)	3	22
IEEE 1394	B	2	23
MINI-PCI	E, F	1	20
LAN	D	0	18
USB 2.0	X	X	X

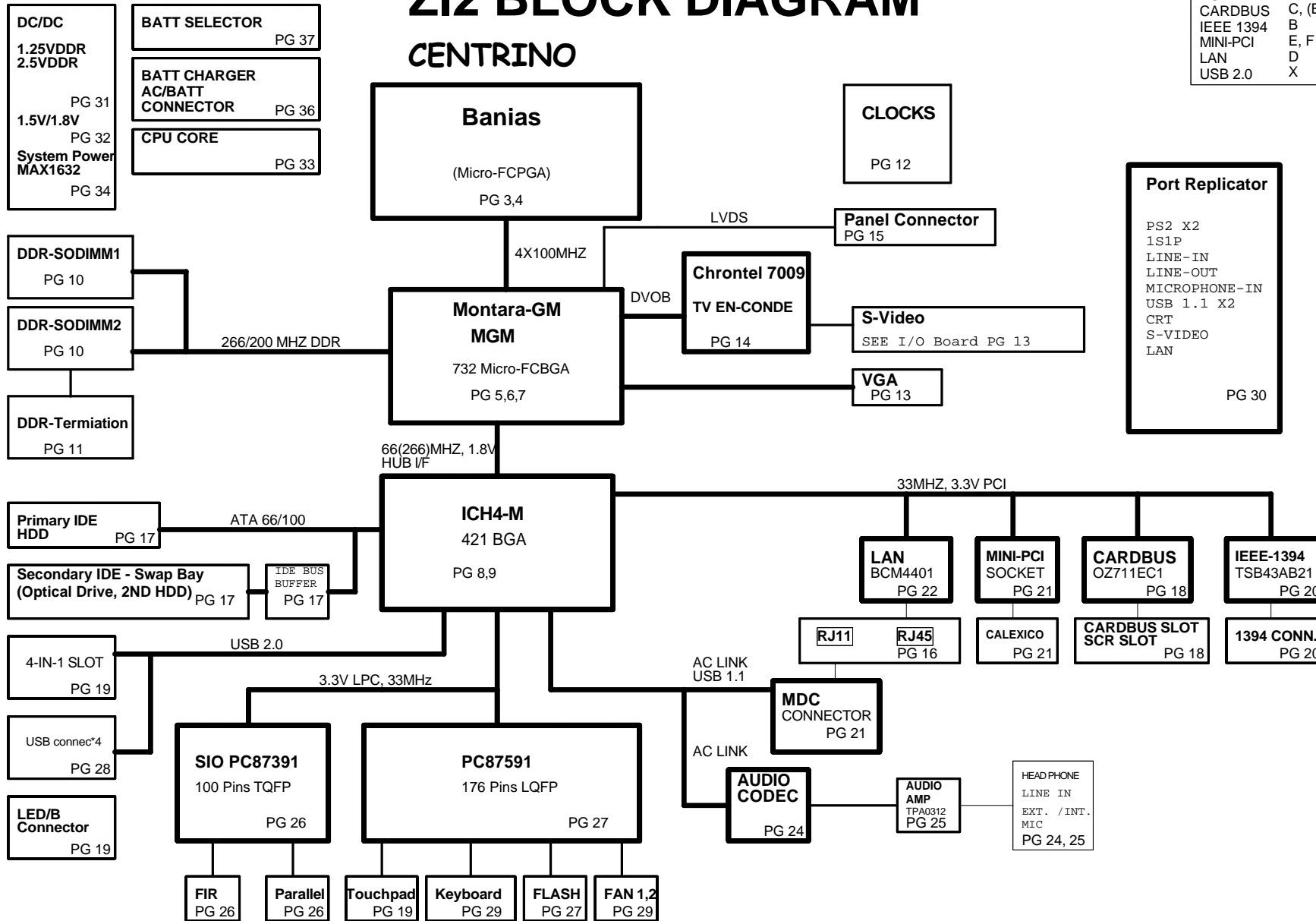

Dr-Bios.com

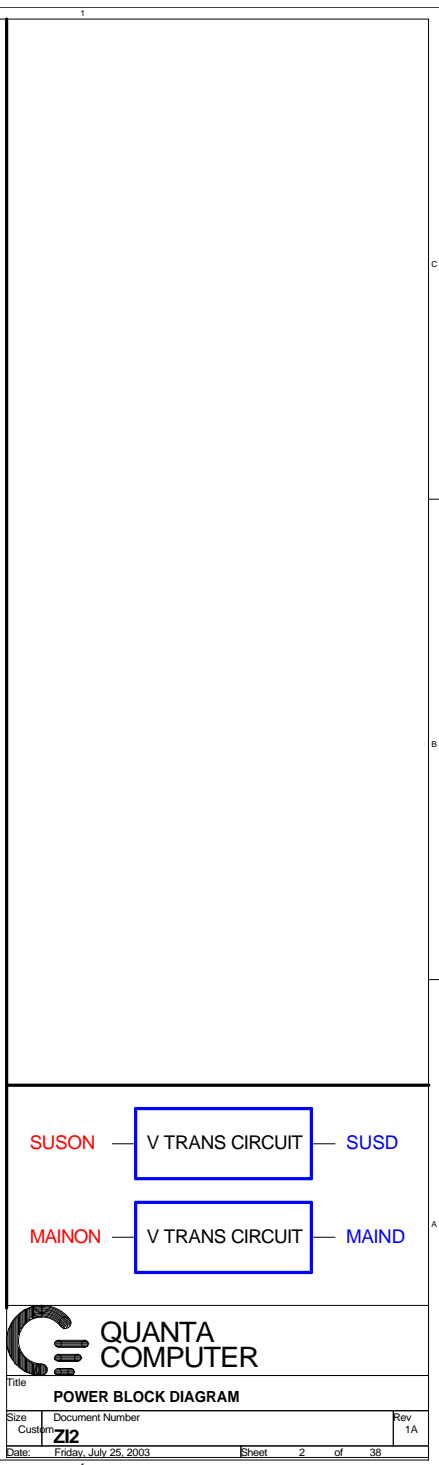
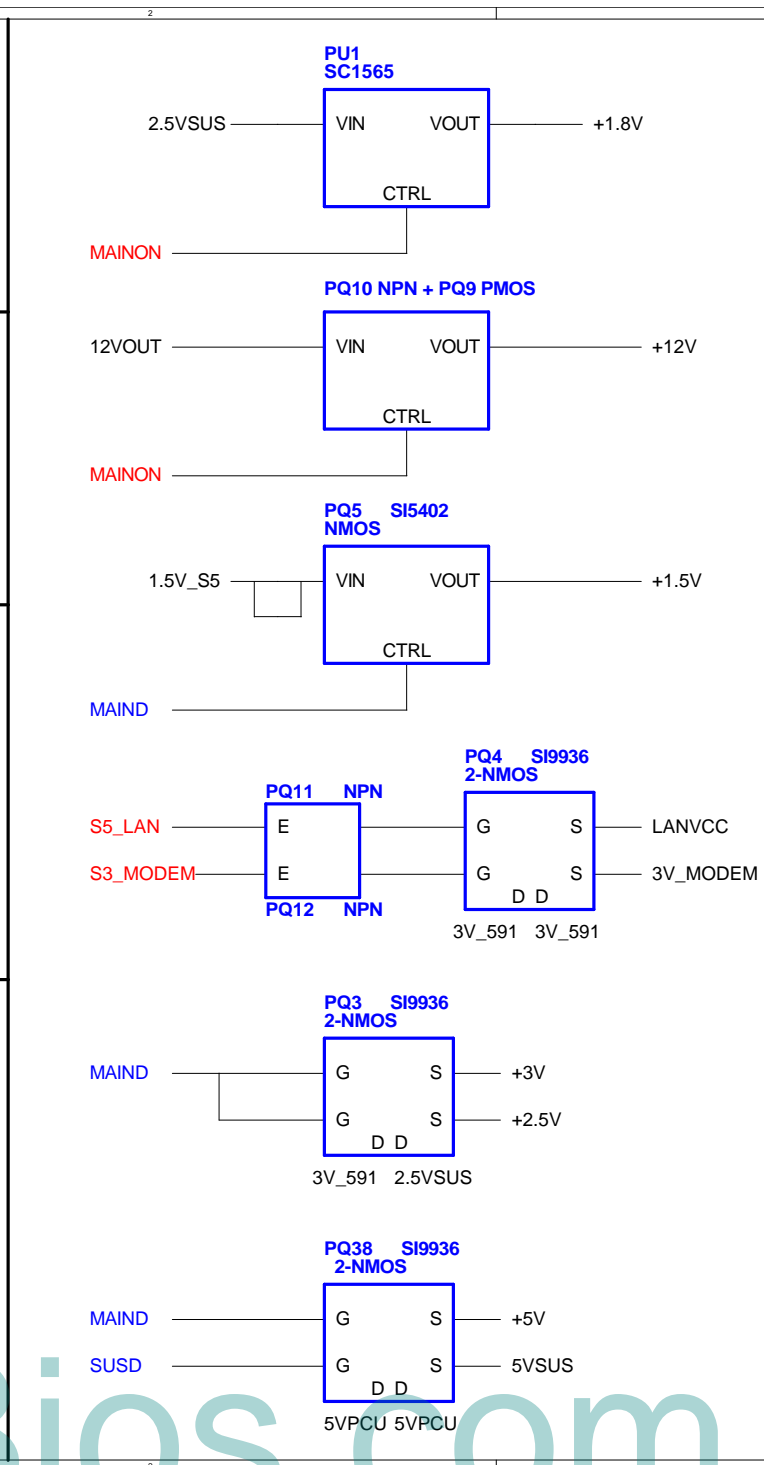
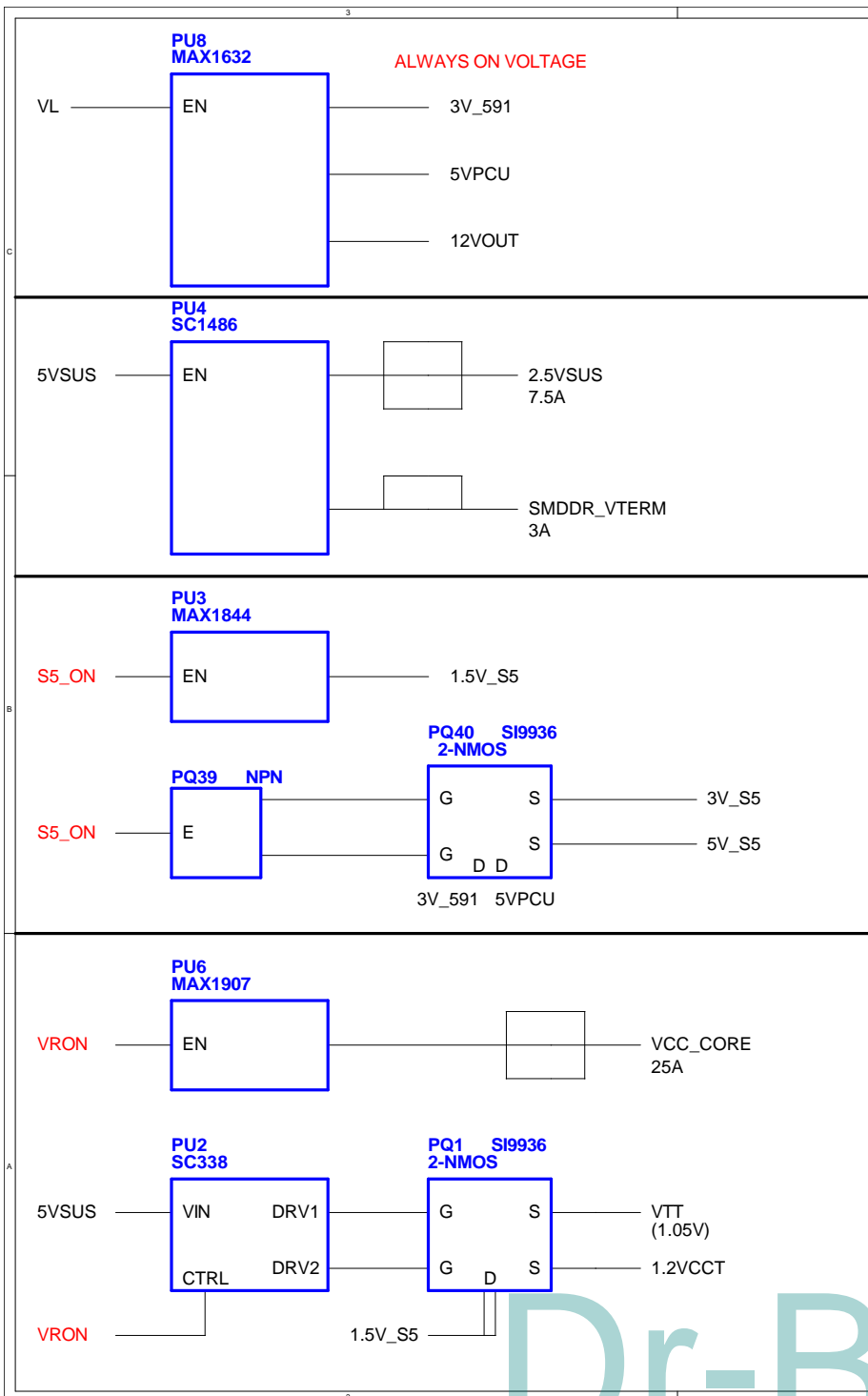

Dr-Bios.com

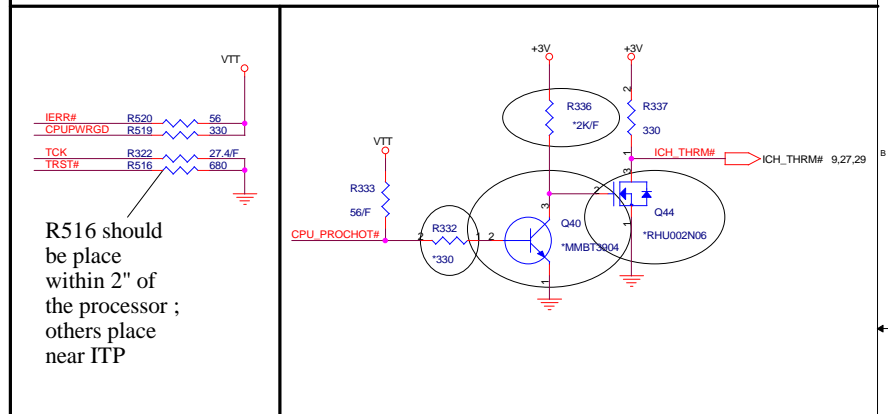
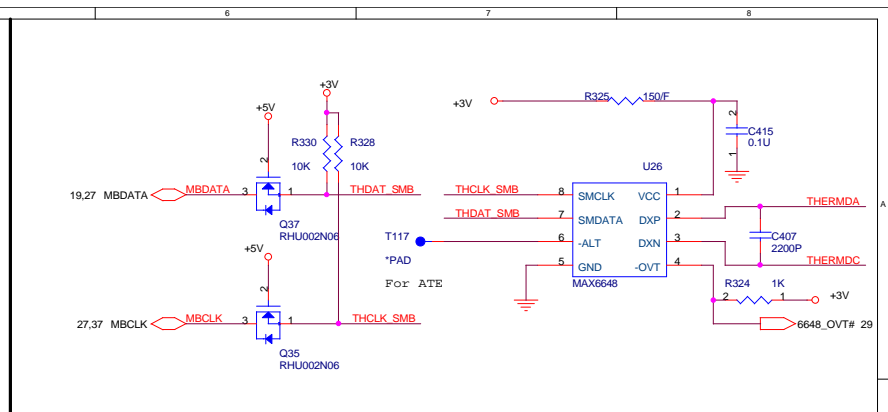
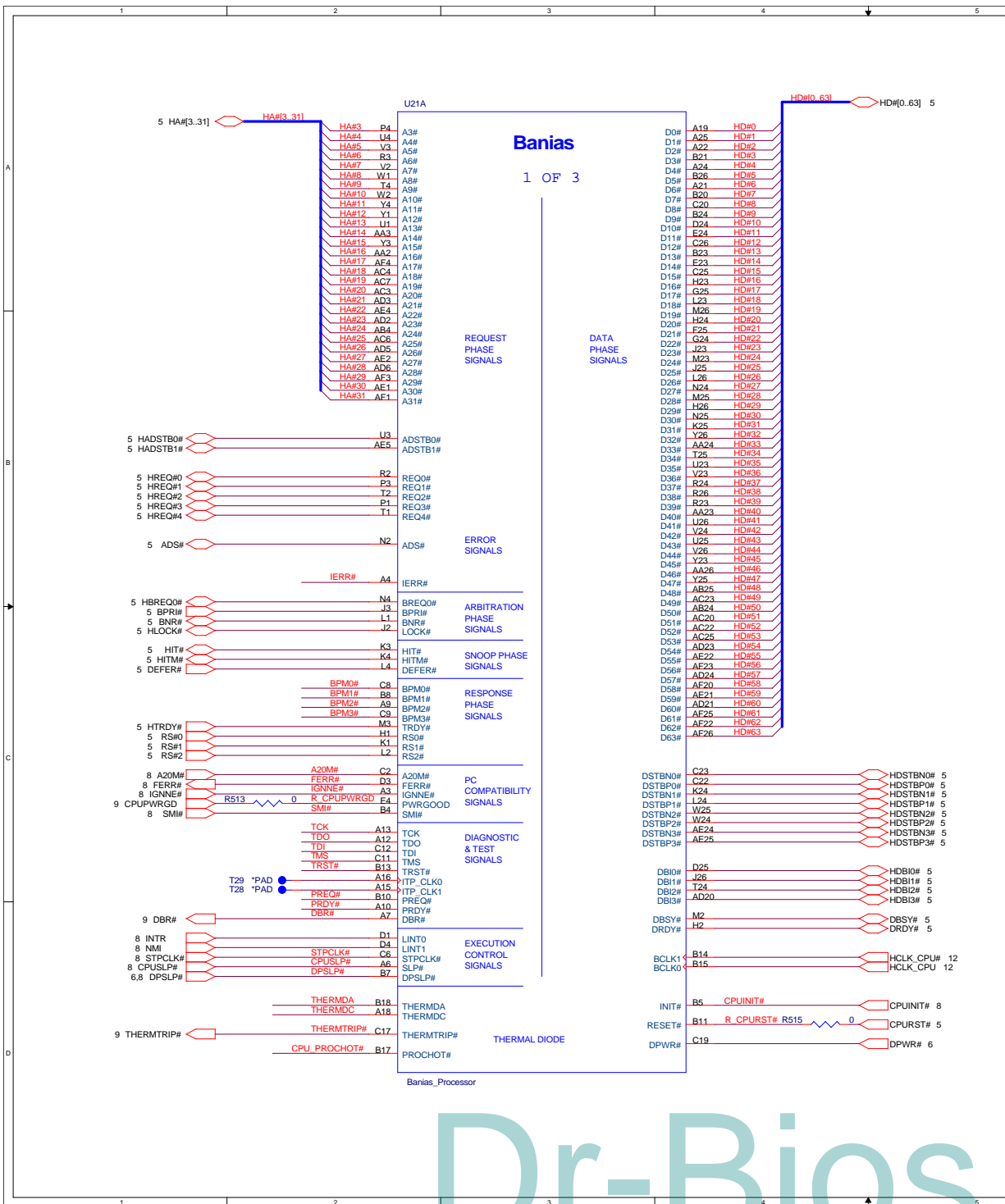

R516 should be place within 2" of the processor ; others place near ITP

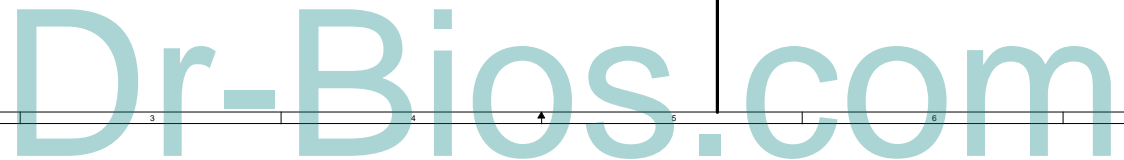
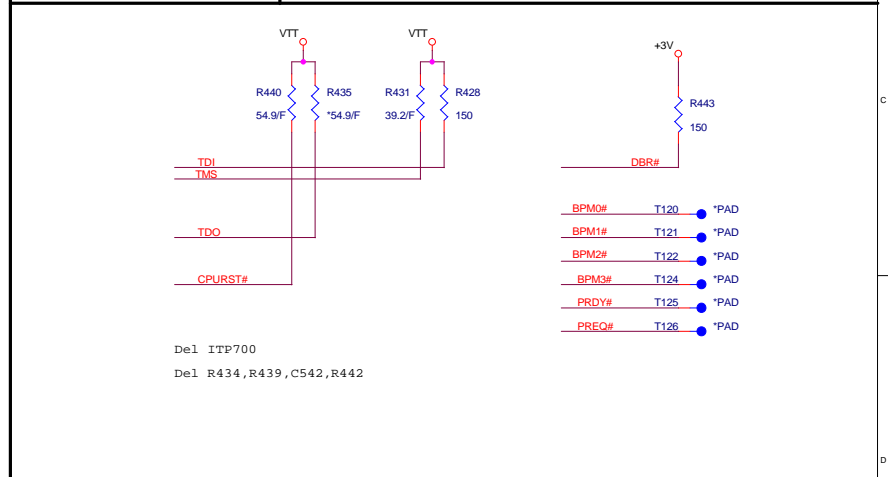

These 4 Resistors need to place with 0.5" of CPU.
 Comp0,2 trace need to be zo=27.4 ohm,
 comp1,3 traces need to be zo=55 ohm.

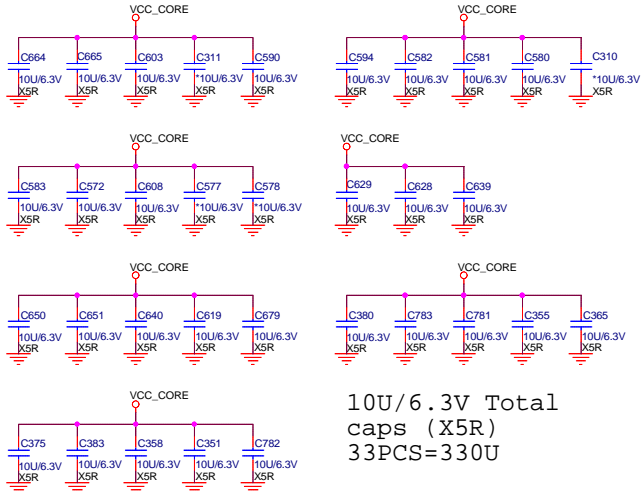
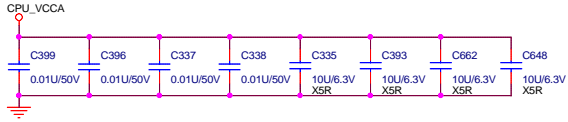
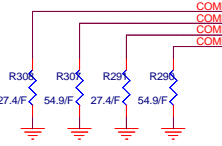

10U/6.3V Total
 caps (X5R)
 33PCS=330U

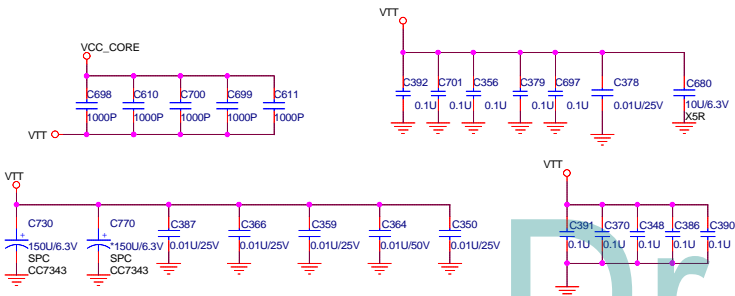

GTLREF: 2/3 VCCP+-2%
 T<0.5" 25 mils space

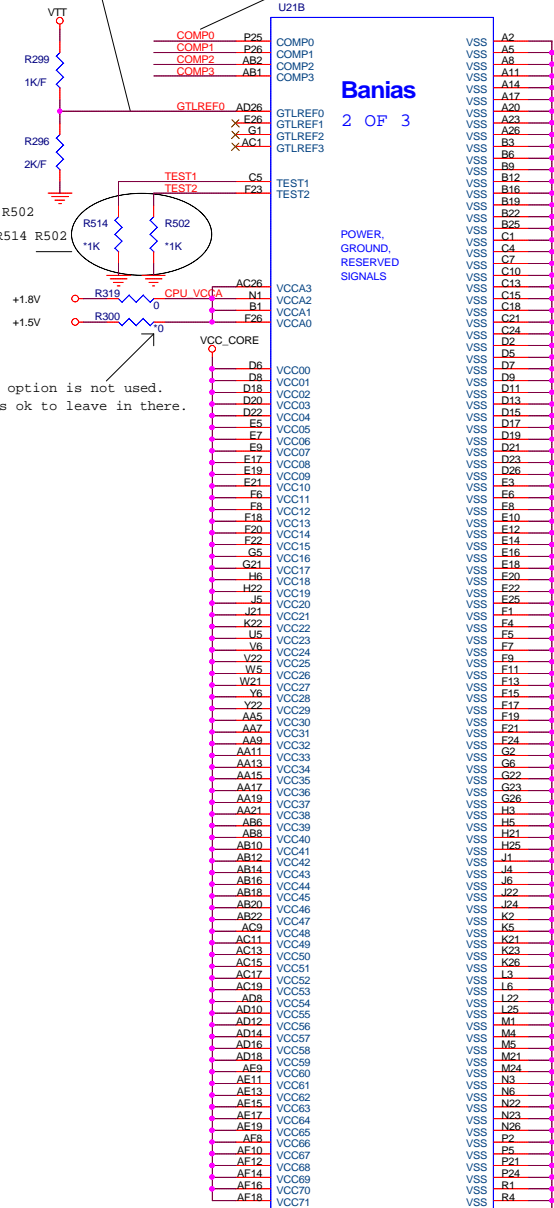

Banias
 2 OF 3

POWER, GROUND, RESERVED SIGNALS

Banias_Processor

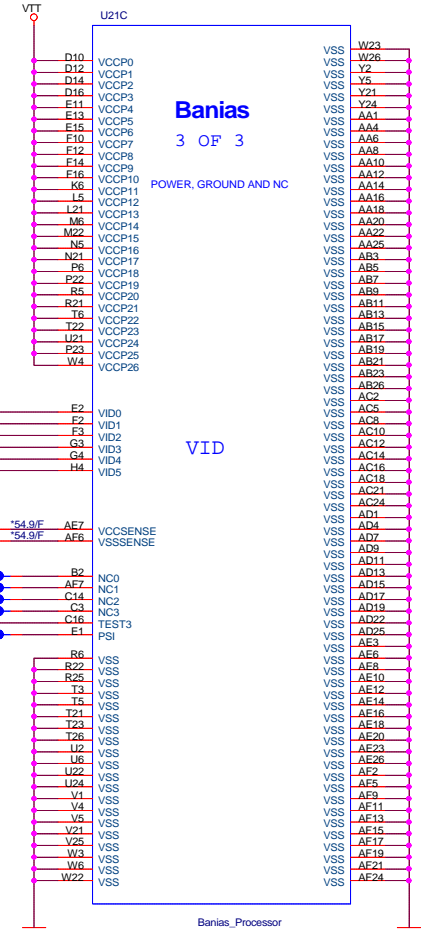

Banias
 3 OF 3

POWER, GROUND AND NC

VID

Banias_Processor

* VCC_BOOT 1.2V
 VCC_CORE 1.468V
 (DEEPER SLEEP) 0.956V
 VTT 1.05V
 VCCA 1.8V



Title Banias Processor (POWER)		
Size Z12	Document Number 712	Rev 3A
Date Friday, July 25, 2003	Sheet 4	of 38

Dr-Bios.com

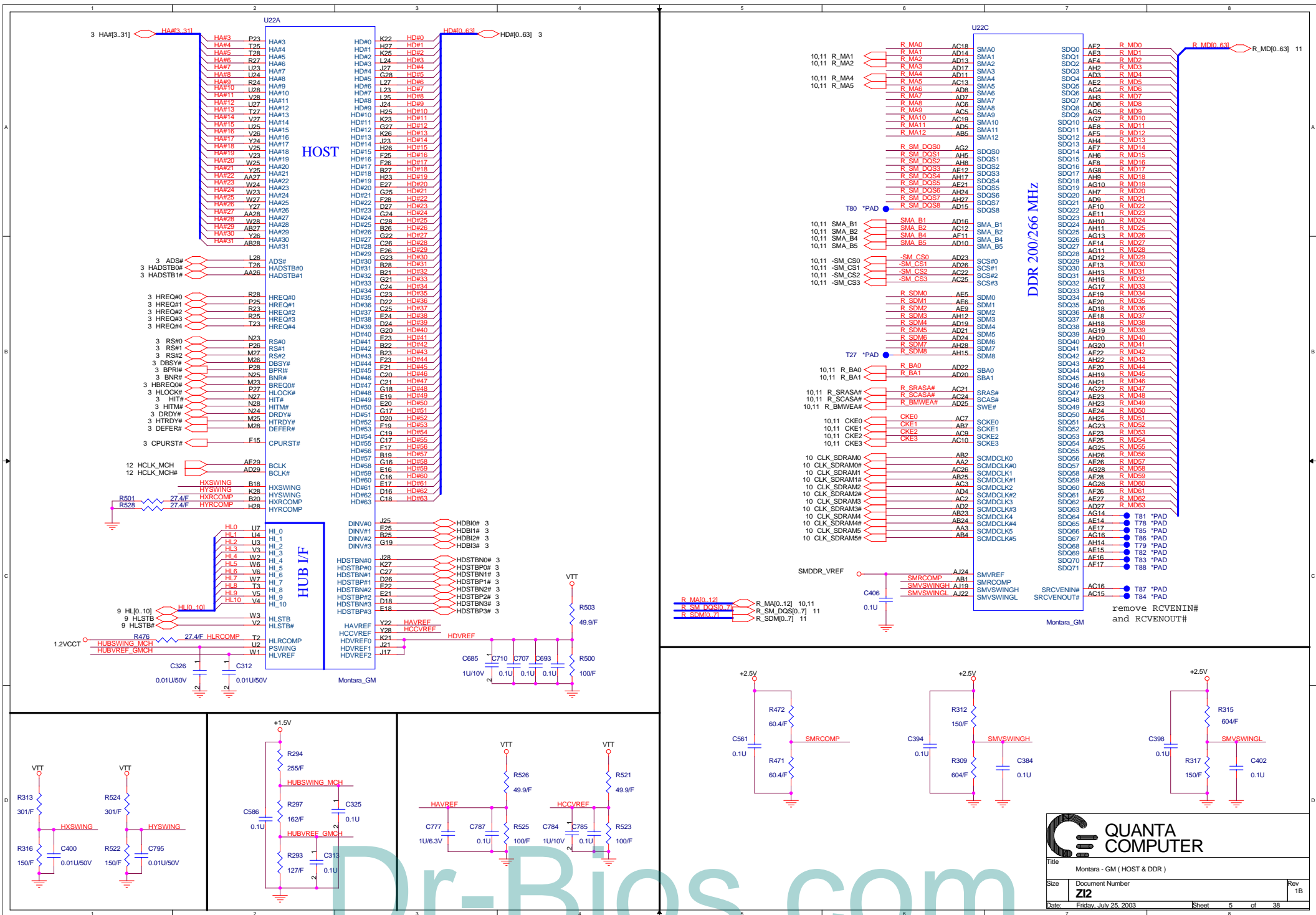

QUANTA COMPUTER

Title: Montara - GM (HOST & DDR)

Size: Document Number **Z12** Rev 1B

Date: Friday, July 25, 2003 Sheet 5 of 38

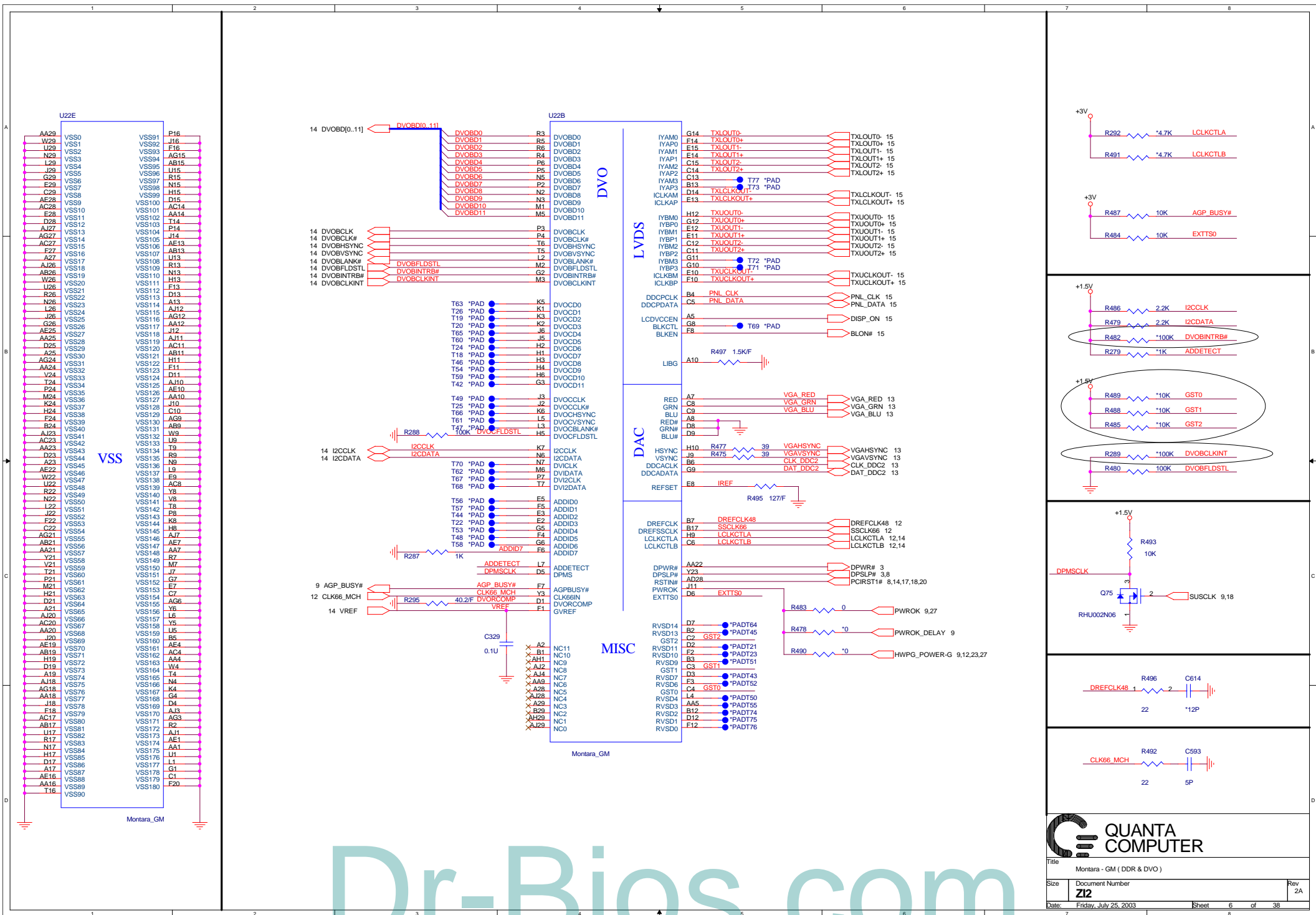

Dr-Bios.com

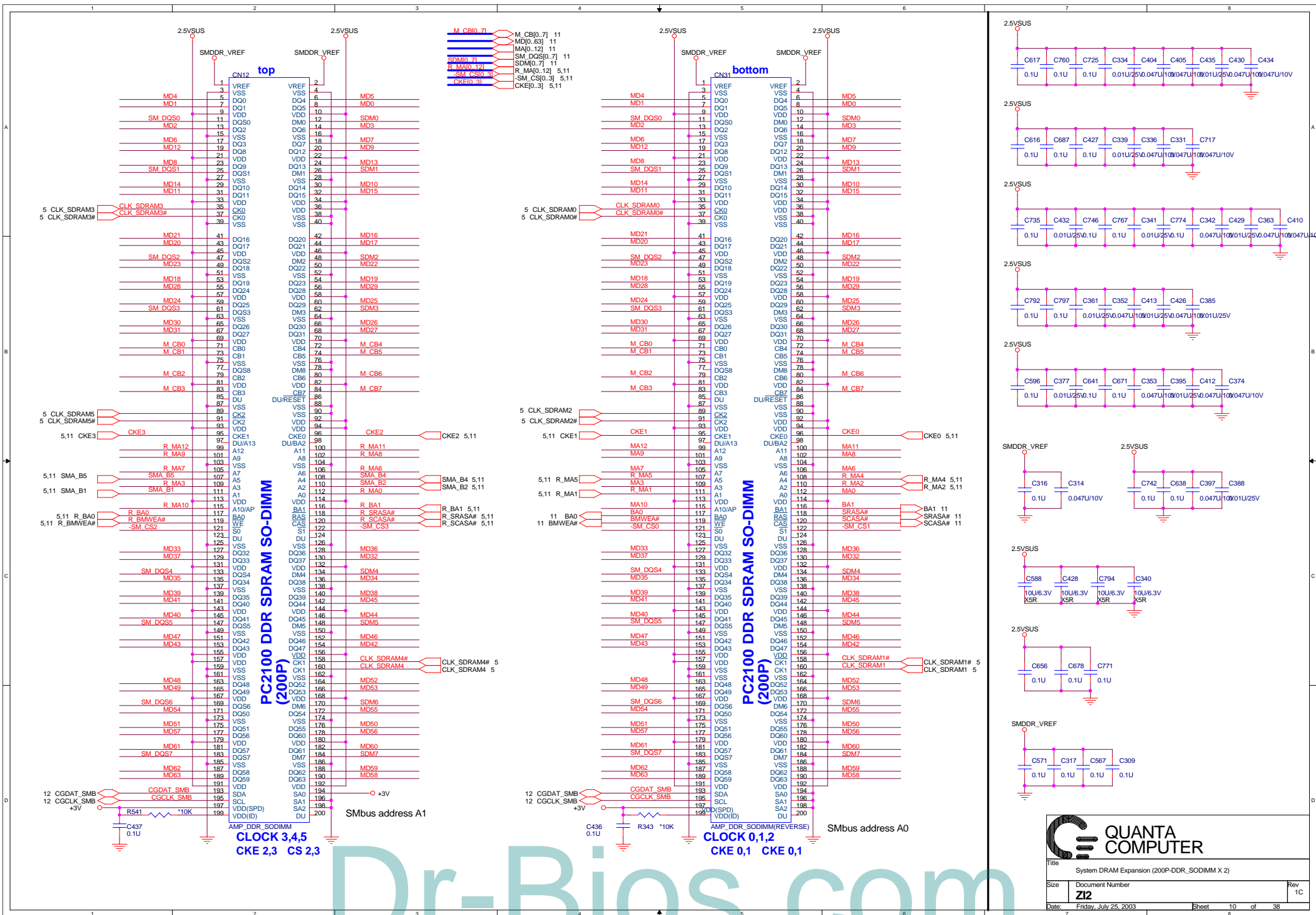

Dr-Bios.com

QUANTA COMPUTER

Title: System DRAM Expansion (200P-DDR_SODIMM X 2)

Size	Document Number	Rev
	Z12	1C

Date: Friday, July 25, 2003 Sheet 10 of 38

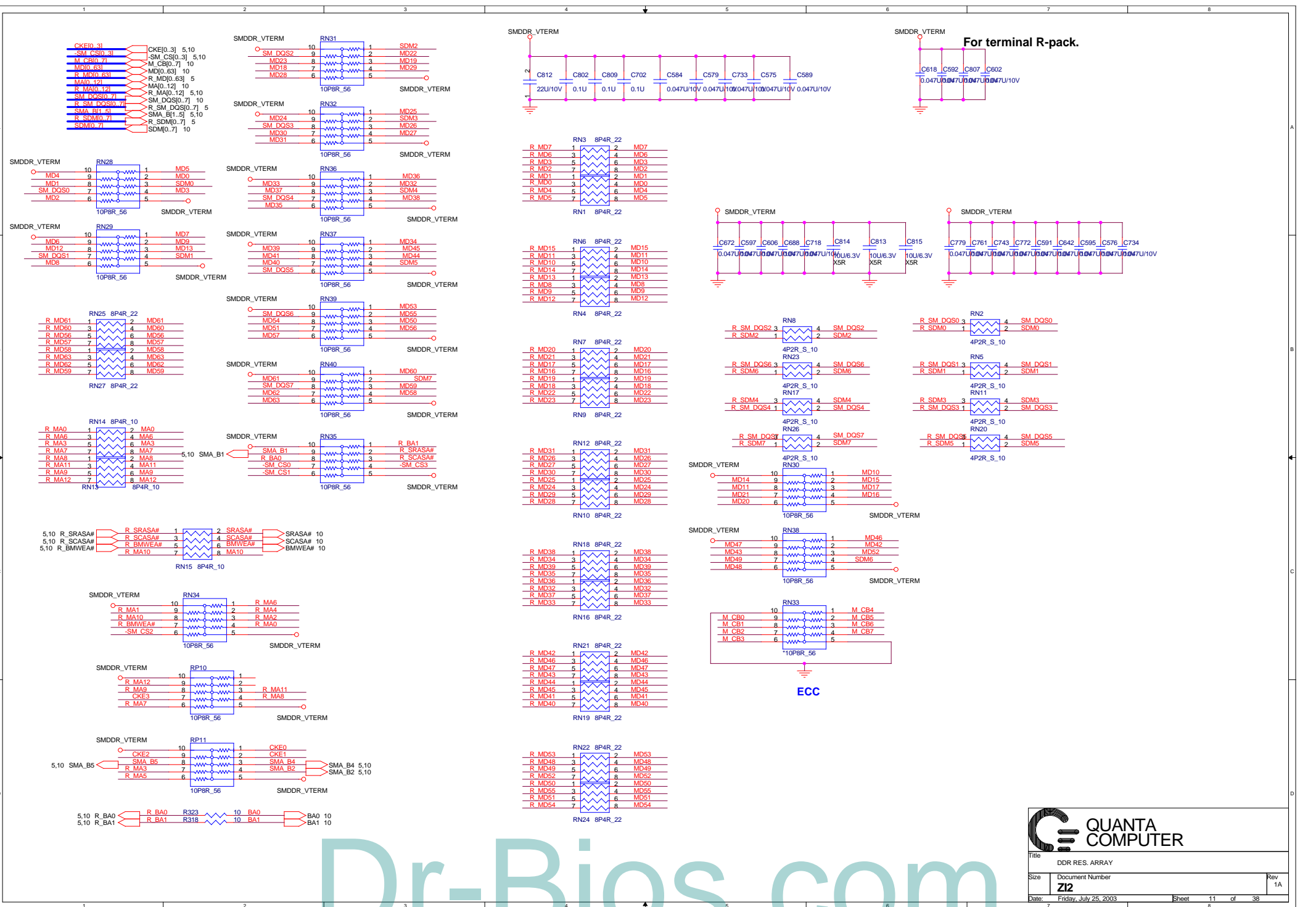

Dr-Bios.com

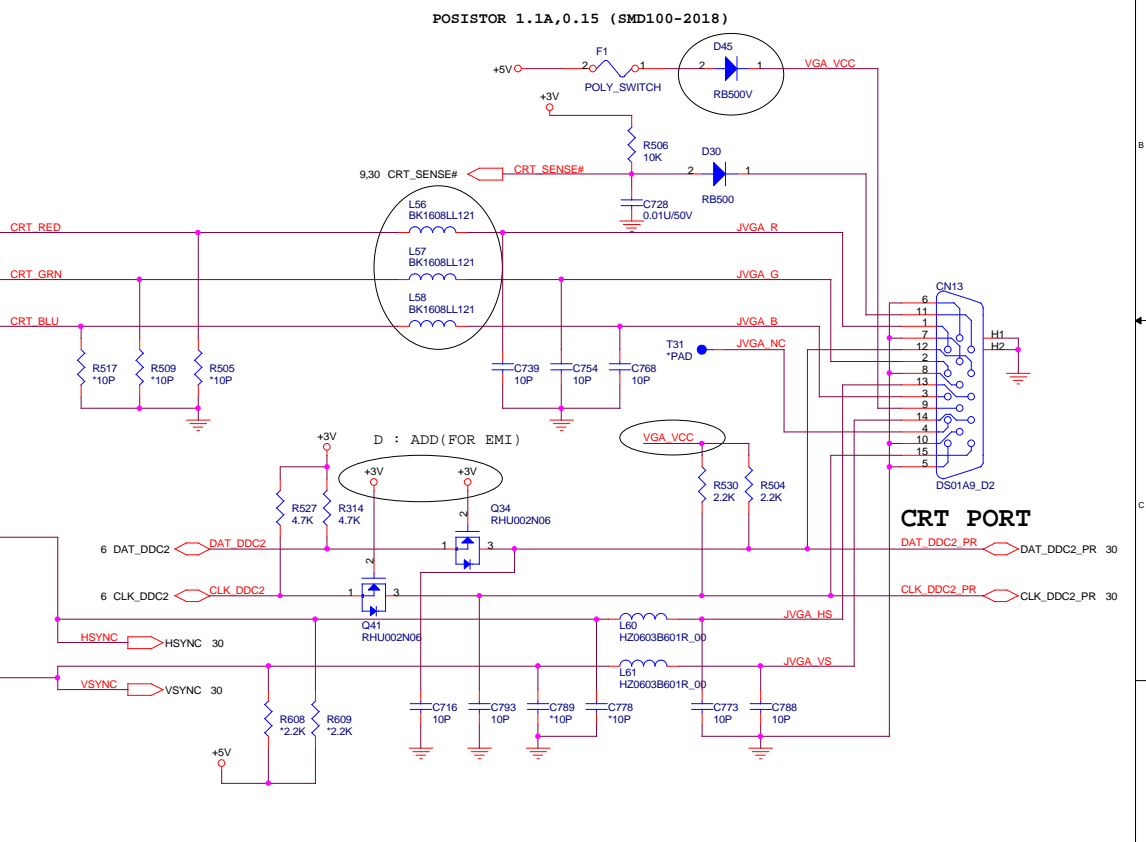
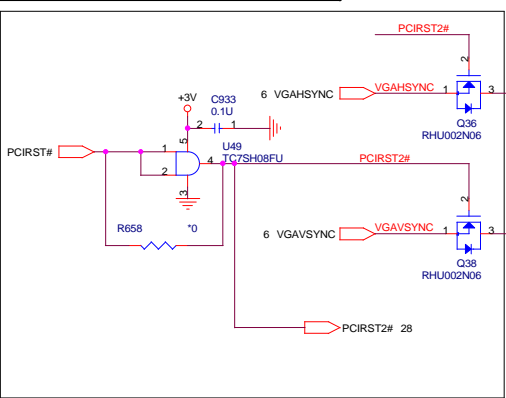
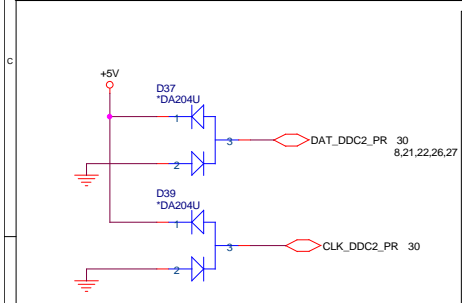
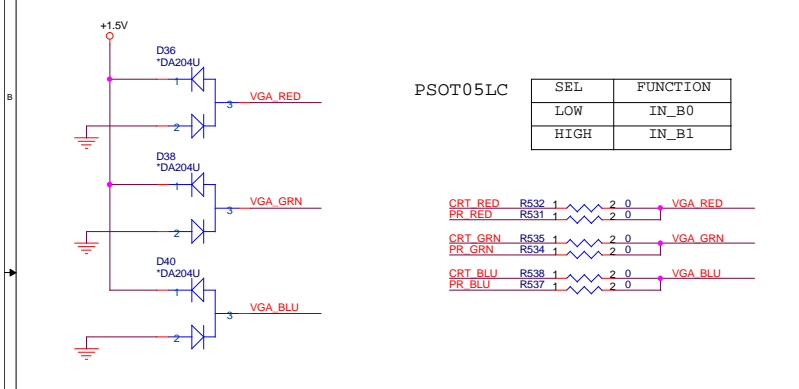
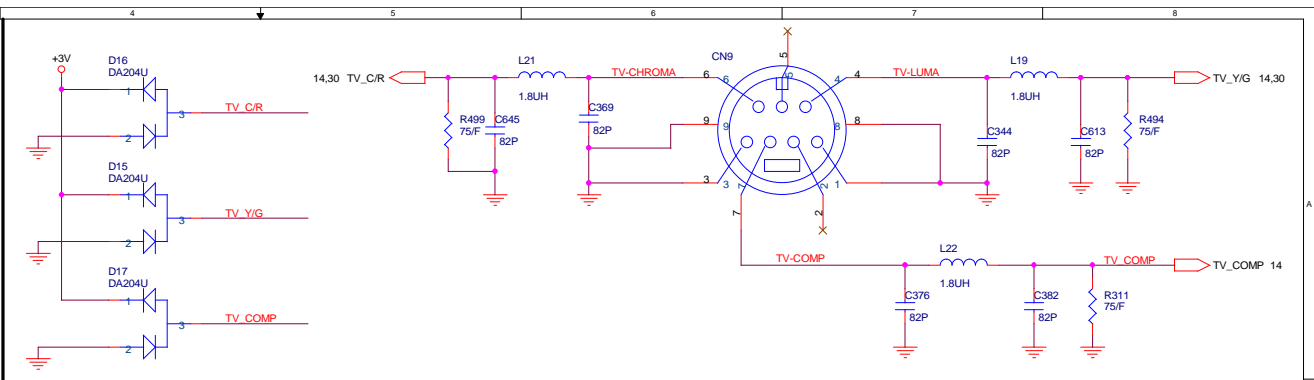
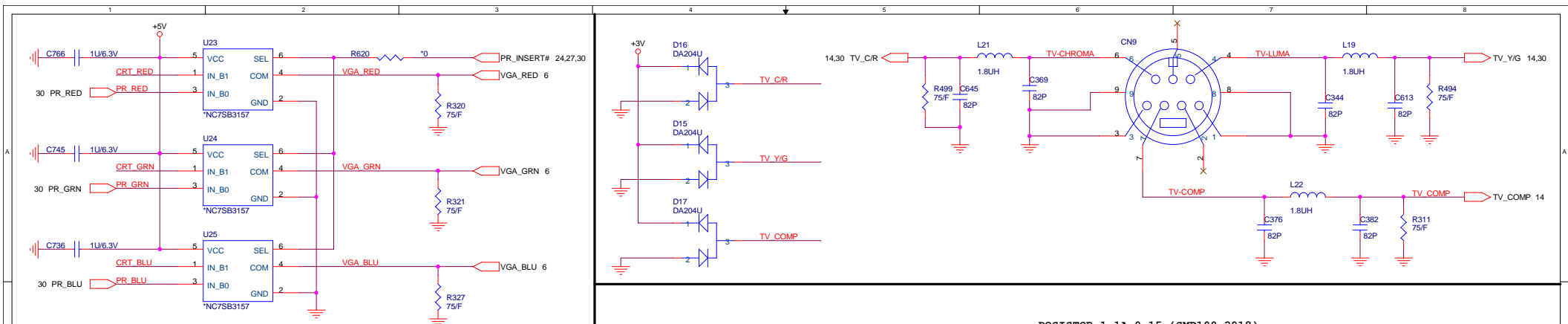

Dr-Bios.com

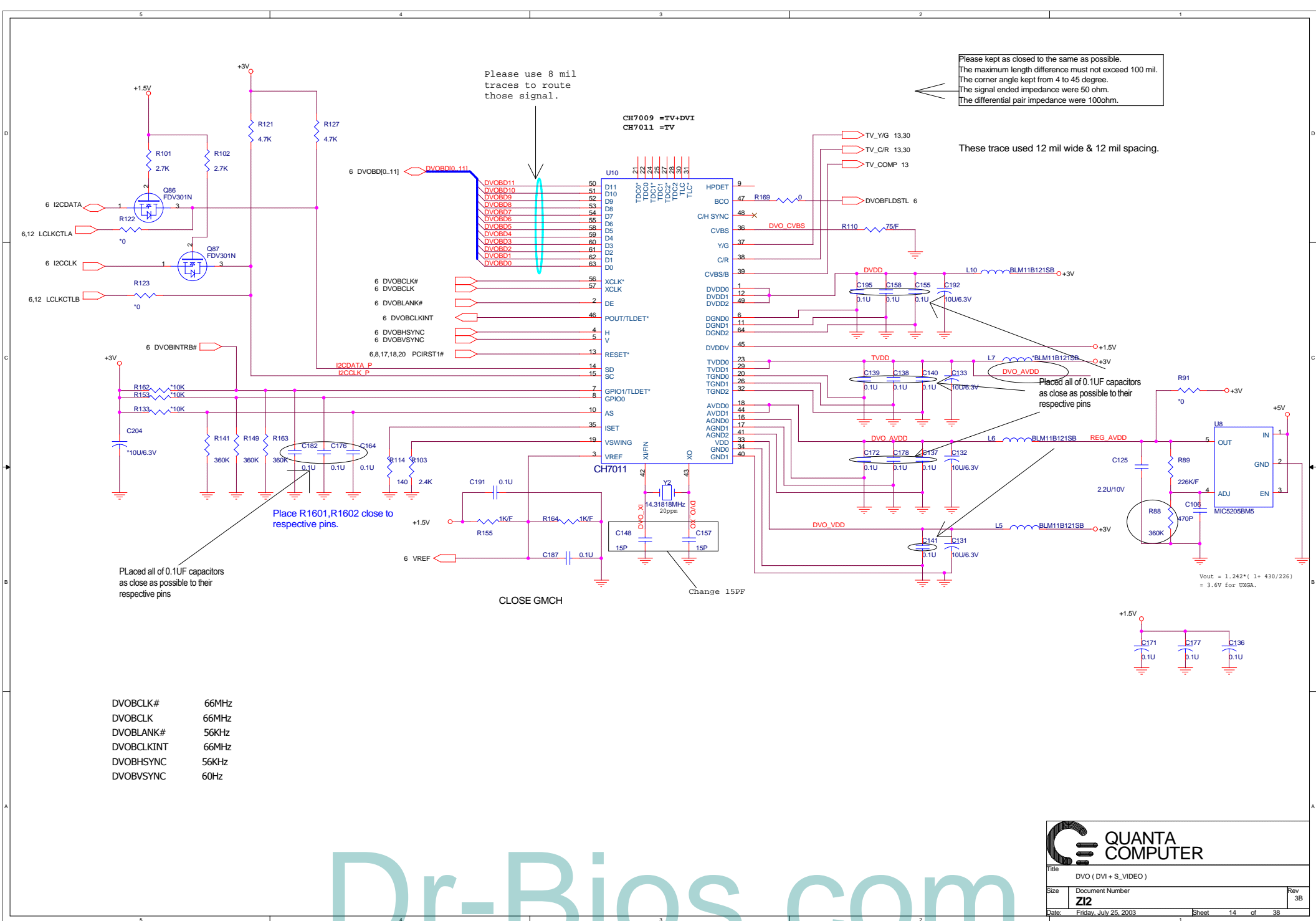

Please use 8 mil traces to route those signal.

Please kept as closed to the same as possible.
 The maximum length difference must not exceed 100 mil.
 The corner angle kept from 4 to 45 degree.
 The signal ended impedance were 50 ohm.
 The differential pair impedance were 100ohm.

These trace used 12 mil wide & 12 mil spacing.

Place R1601,R1602 close to respective pins.

Placed all of 0.1uF capacitors as close as possible to their respective pins

Placed all of 0.1uF capacitors as close as possible to their respective pins

CLOSE GMCH

Change 15PF

$$V_{out} = 1.242 * (1 + 430/226) = 3.6V \text{ for } 0VGA.$$

DVOBCLK#	66MHz
DVOBCLK	66MHz
DVOBLANK#	56KHz
DVOBCLKINT	66MHz
DVOBHSYNC	56KHz
DVOBVSNC	60Hz

Dr-Bios.com

QUANTA COMPUTER

Title: DVO (DVI + S_VIDEO)

Size: Document Number **Z12** Rev: 3B

Date: Friday, July 25, 2003 Sheet 14 of 38

FILTER FBM2125 HM330-T (4A, 0.015)

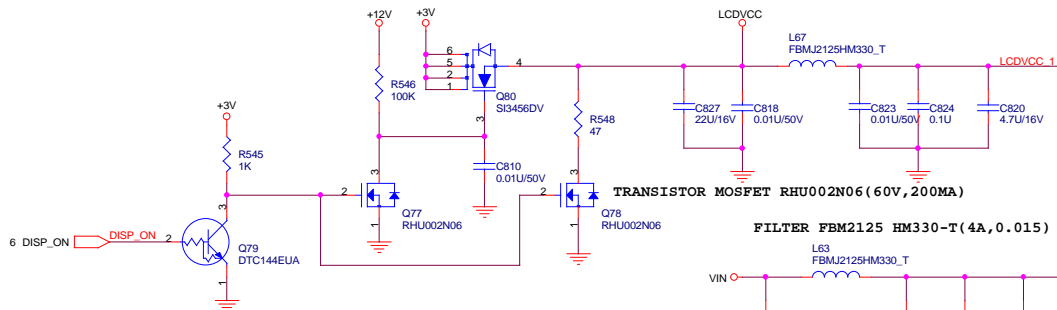

FILTER FBM2125 HM330-T (4A, 0.015)

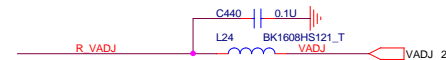
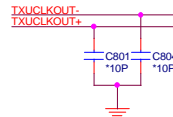
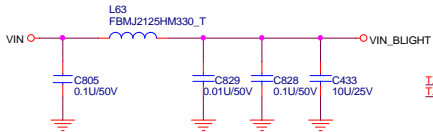

PANEL ID:

	PANEL_ID2	PANEL_ID1	PANEL_ID0
ID3 XGA	0	1	1
ID4 UXGA	1	0	0
ID5 SXGA+	1	0	1
ID6 SXGA	1	1	0
ID7 NC	1	1	1

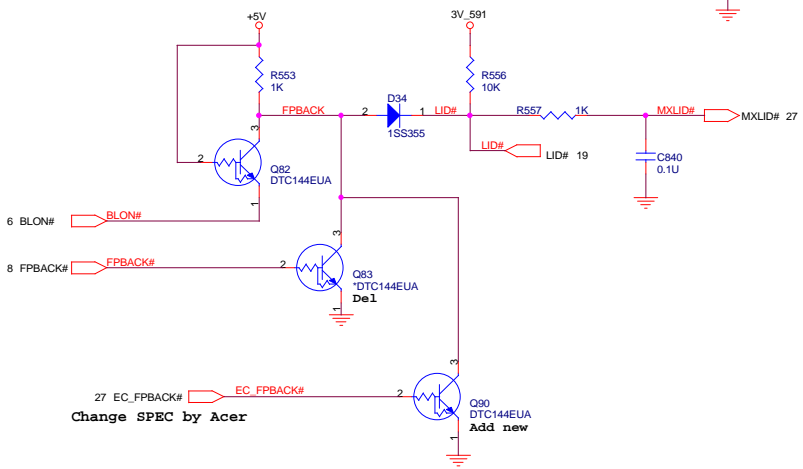
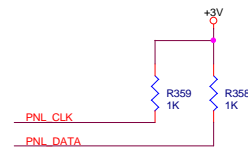

Change SPEC by Acer

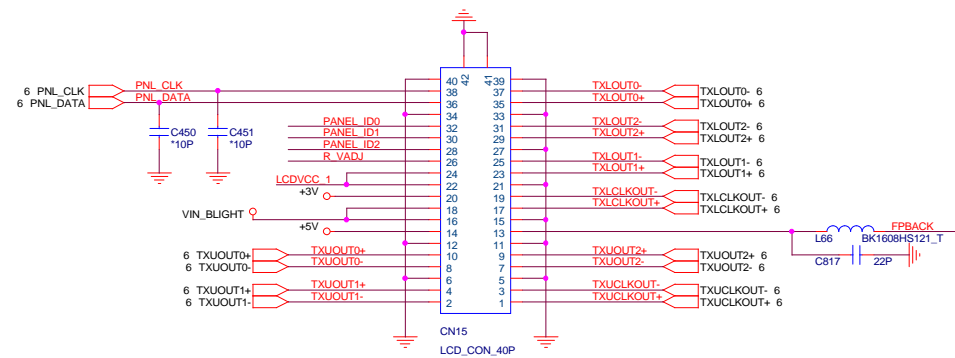

QUANTA COMPUTER

Title: **LCD CONN**

Size: Custom
 Document Number: **Z12**
 Date: Friday, July 25, 2003

Rev: 3A

Sheet: 15 of 38

Dr-Bios.com

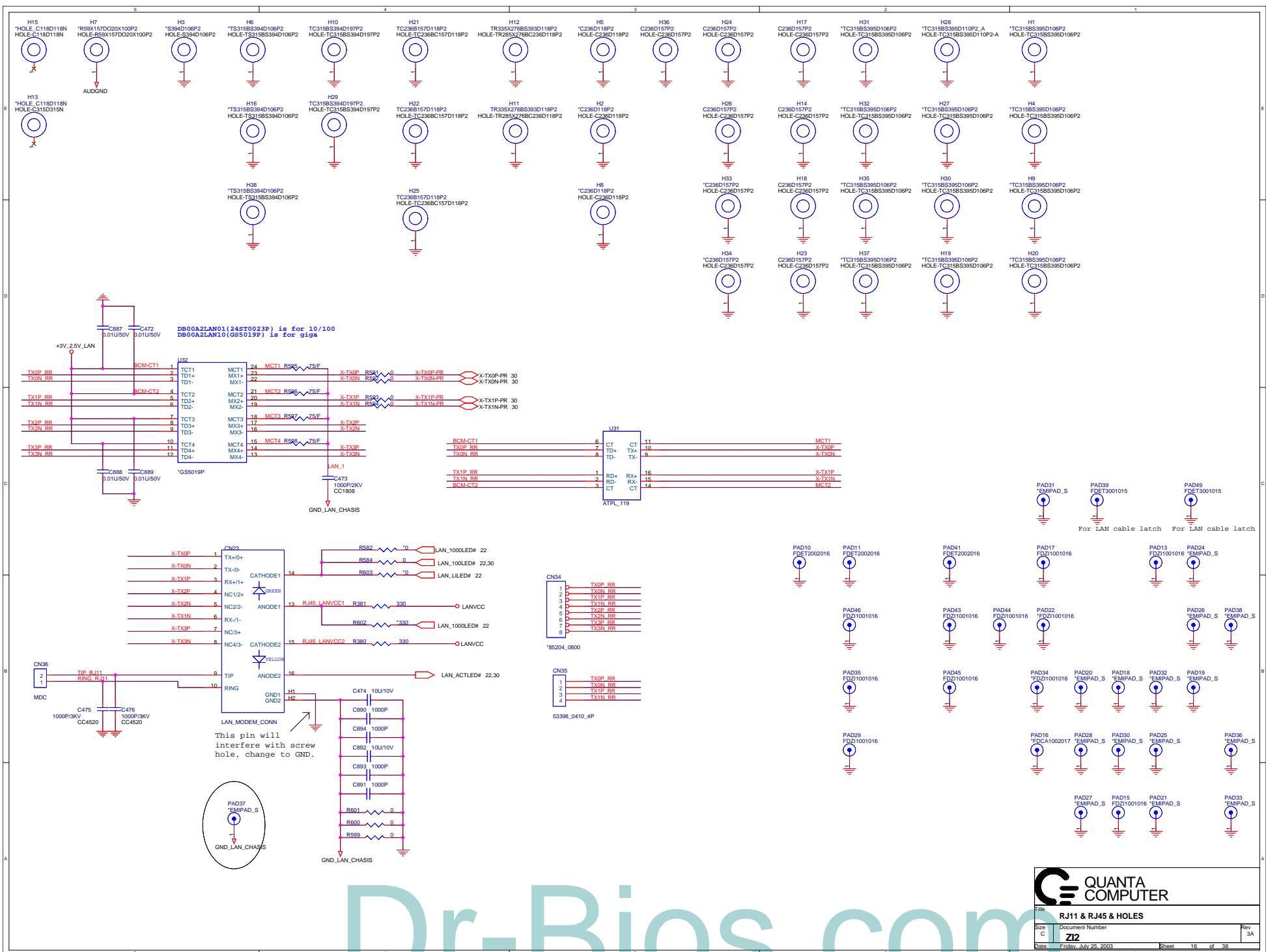

QUANTA COMPUTER

Title: **RJ11 & RJ45 & HOLES**

Size: C Document Number: **Z1Z** Rev: 3A

Date: Friday, July 25, 2003 Sheet: 16 of 38

Dr-Bios.com

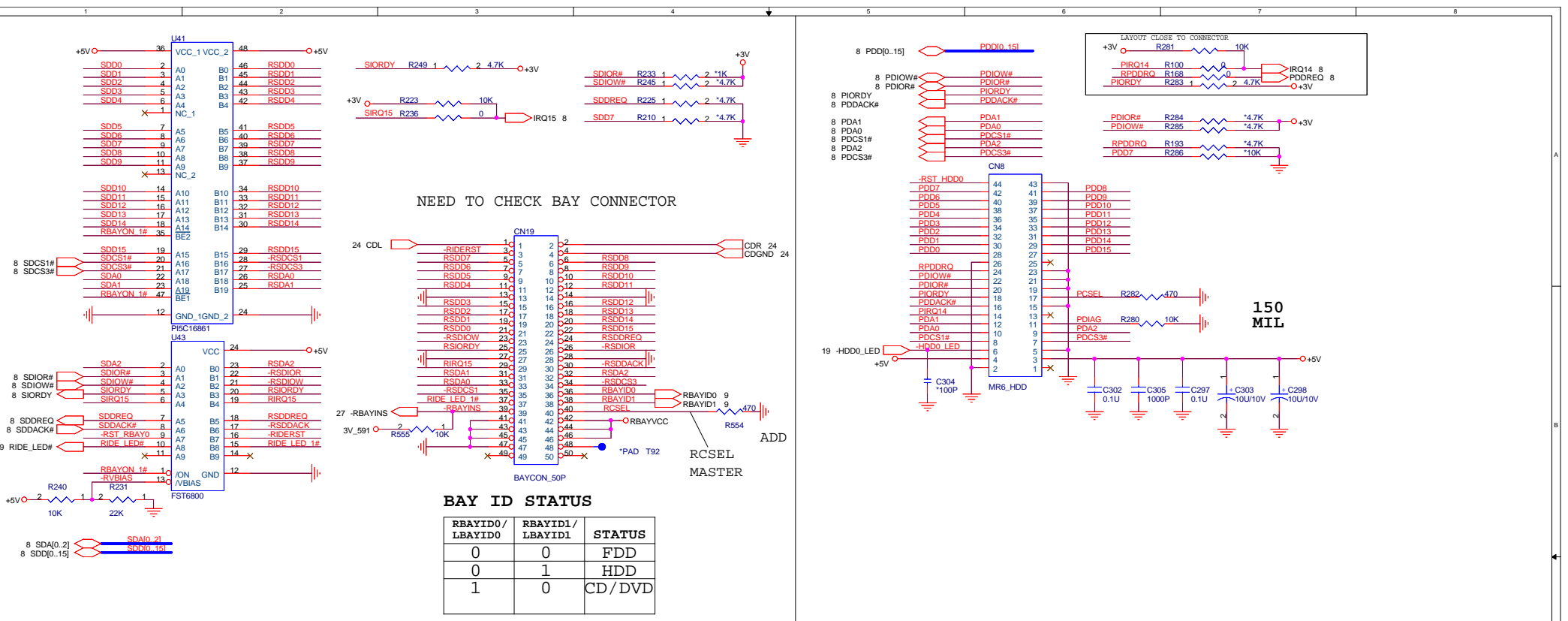

SWAP BAY: OPTICAL DRIVE, 2ND BATTERY, 2ND HDD

HDD CONNECTOR

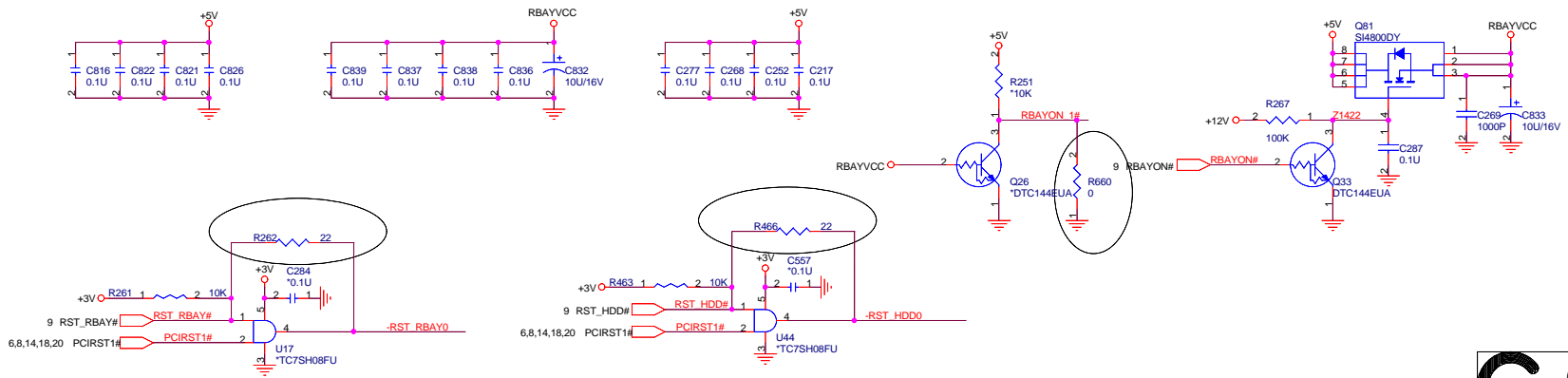

SWAP BAY POWER CONTROL& RESET

QUANTA COMPUTER

Title: **DEVICE BAY**

Size: Custom
 Document Number: **Z12**
 Date: Friday, July 25, 2003
 Sheet: 17 of 38

Dr-Bios.com

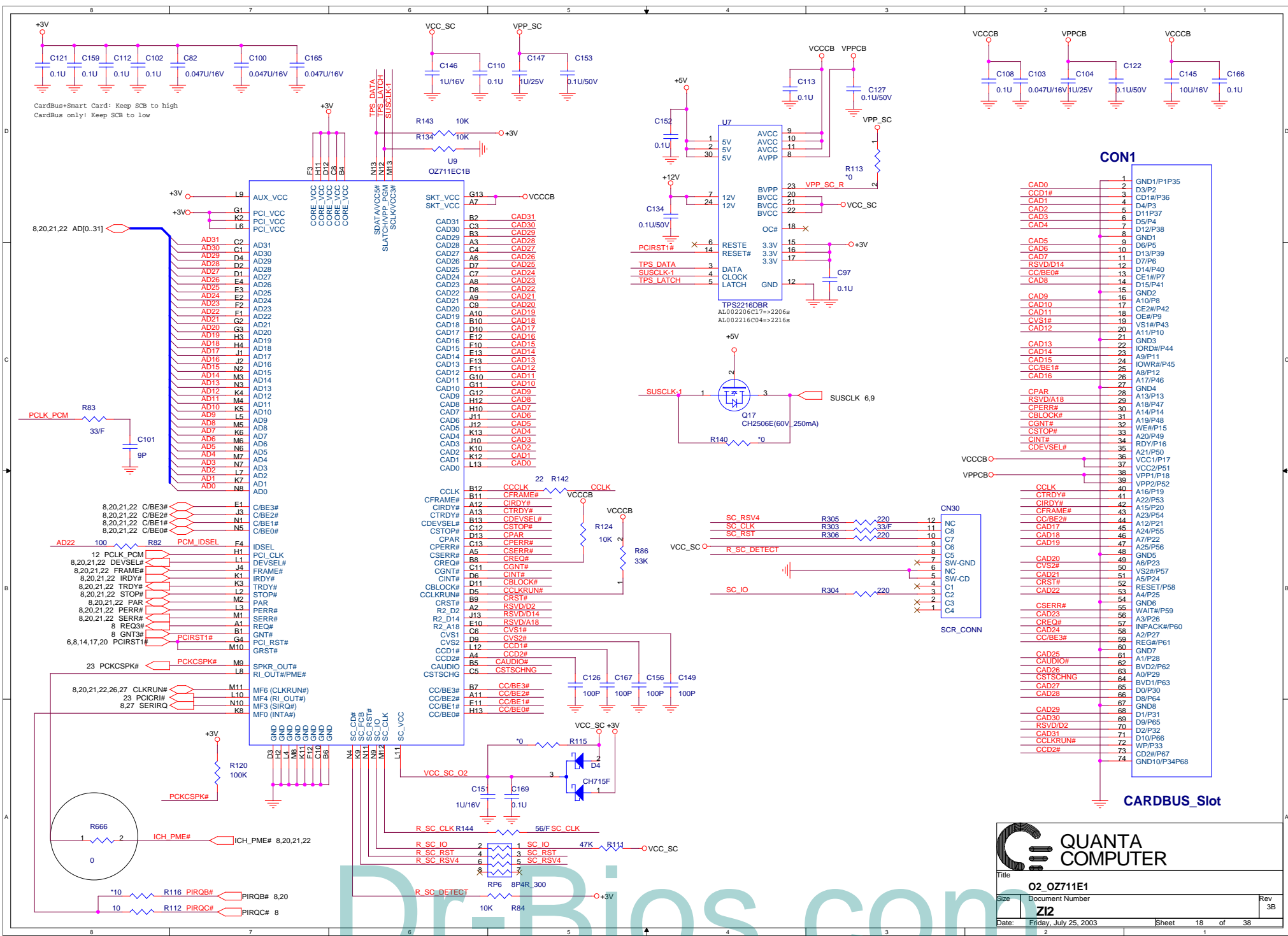

Dr-Bios.com



IEEE-1394

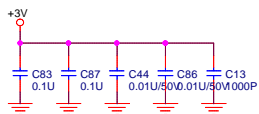

Used for vccp
(Pin20,35,48,62,78)

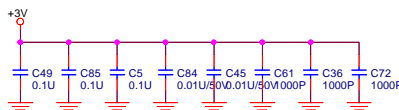

Used for vcc3
(Pin15,27,39,51,59,72,88,100)

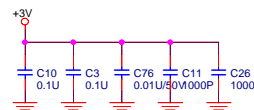

Used for AVCC
(Pin1,2,107,108,120)

ID Select : AD23
Interrupt Pin : PIRQB#
Request indicates : REQ2#
Grant indicates : GNT2#

8,18,21,22 AD[0..31] → AD[0..31]

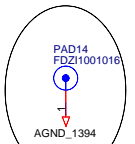
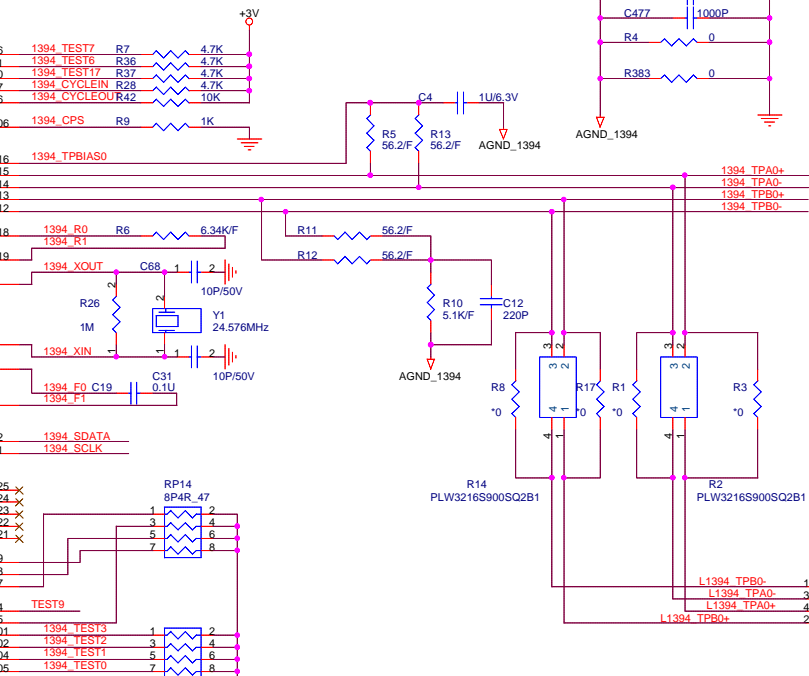
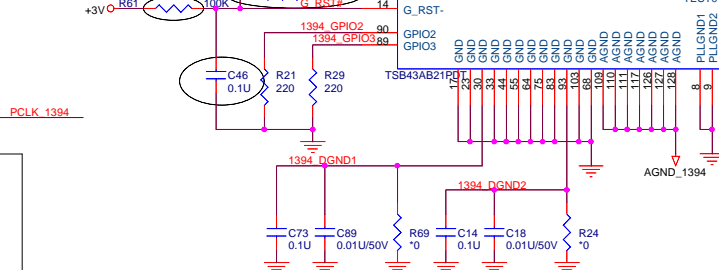
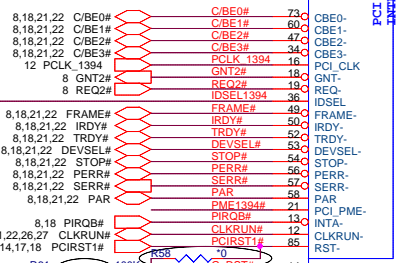
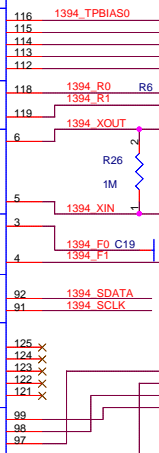
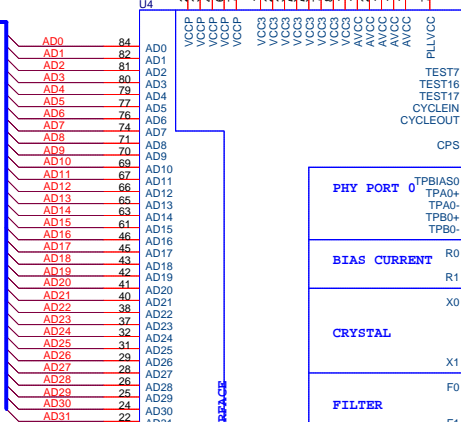

For EMI Request; PAD size is not determined yet.

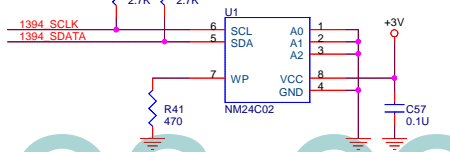

Title		TSB43AB21[1394]	
Size	Document Number	Rev	
Custom	Z12	3B	
Date	Friday, July 25, 2003	Sheet	20 of 38

Dr-Bios.com

ID Select : AD20
Interrupt Pin : PIRQ# , PIRQ#
Request indicates : REQ1#
Grant indicates : GNT1#

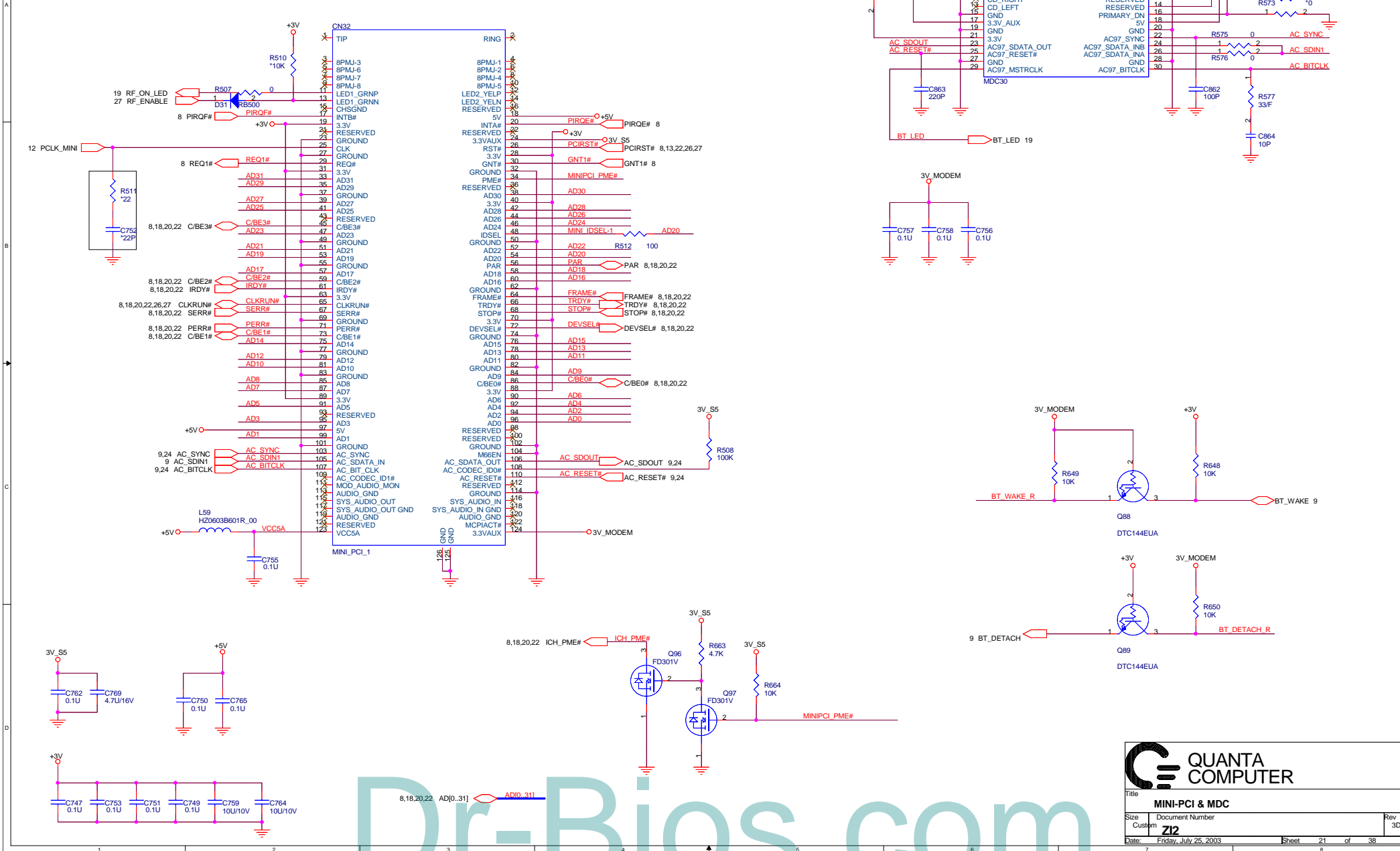

QUANTA COMPUTER
 Title: **MINI-PCI & MDC**
 Size: Custom
 Document Number: **Z12**
 Date: Friday, July 25, 2003
 Sheet: 21 of 38
 Rev: 3D

Dr-Bios.com

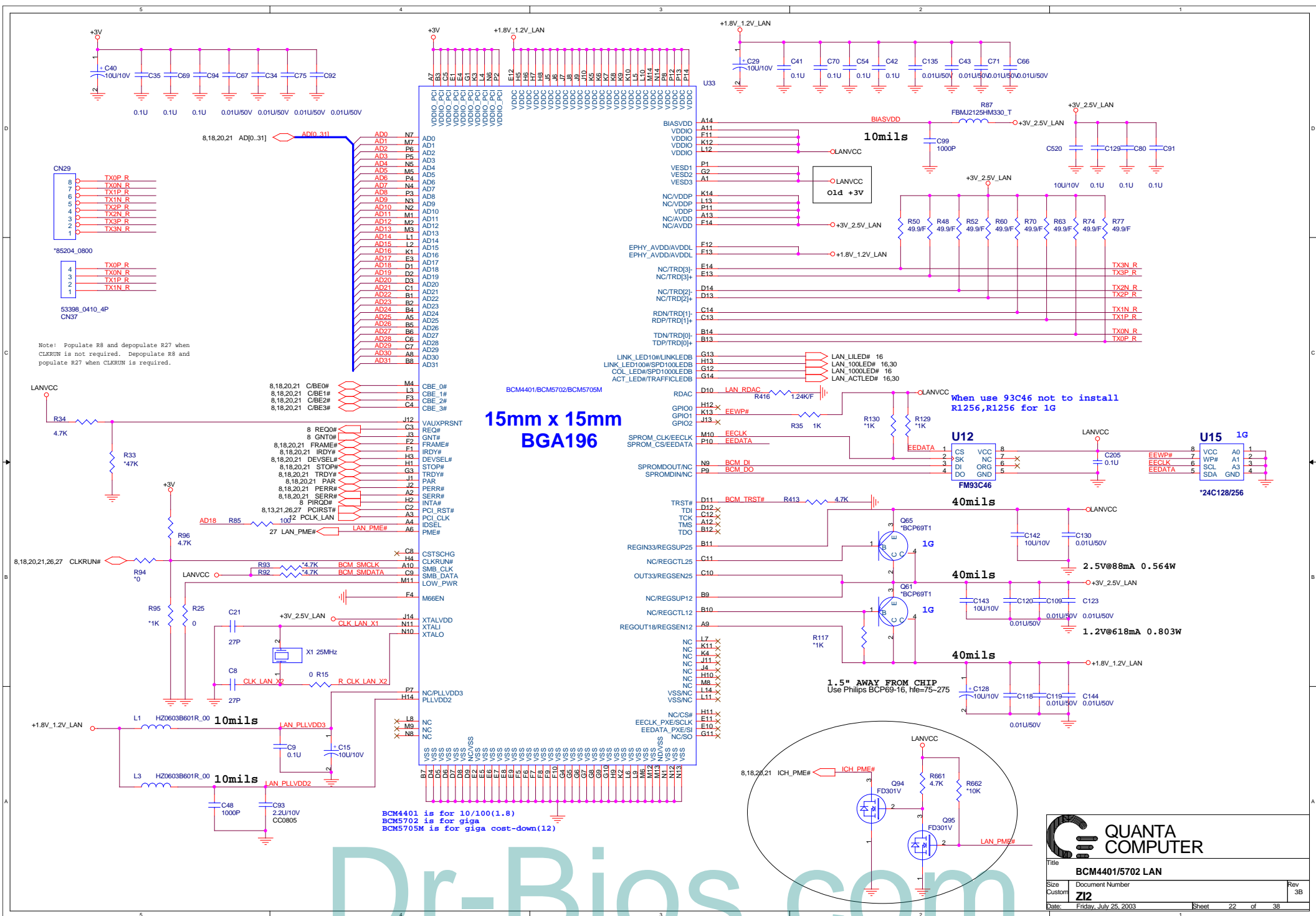

15mm x 15mm BGA196

BCM4401/BCM5702/BCM5705M

BCM4401 is for 10/100(1.8)
 BCM5702 is for giga
 BCM5705M is for giga cost-down(12)

When use 93C46 not to install R1256,R1256 for 1G

40mils

40mils

40mils

1.5" AWAY FROM CHIP
 Use Philips BCP69-16, hfe=75-275

QUANTA COMPUTER

Title: **BCM4401/5702 LAN**

Size: Custom Document Number: **Z12** Rev: 3B

Date: Friday, July 25, 2003 Sheet: 22 of 38

Dr-Bios.com

AUDIO POWER

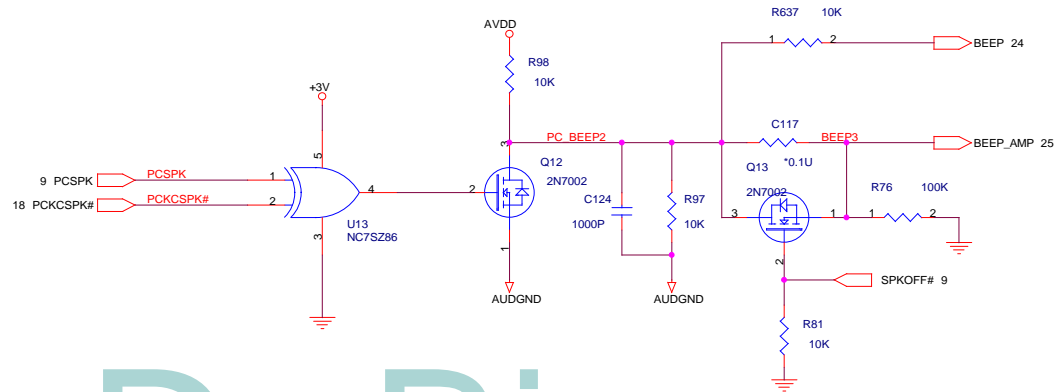
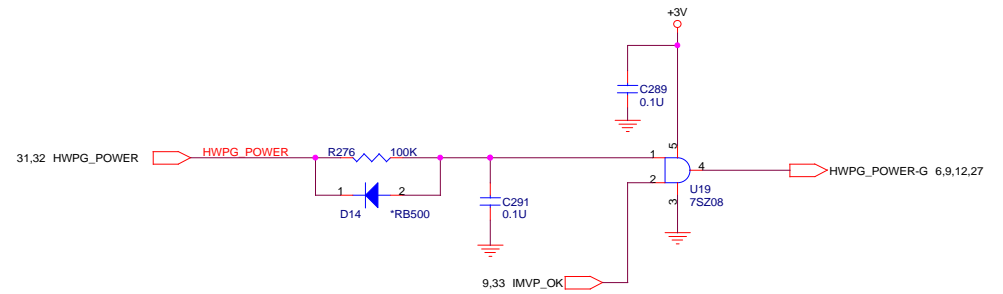
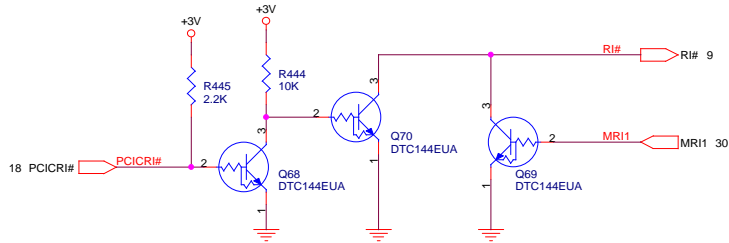
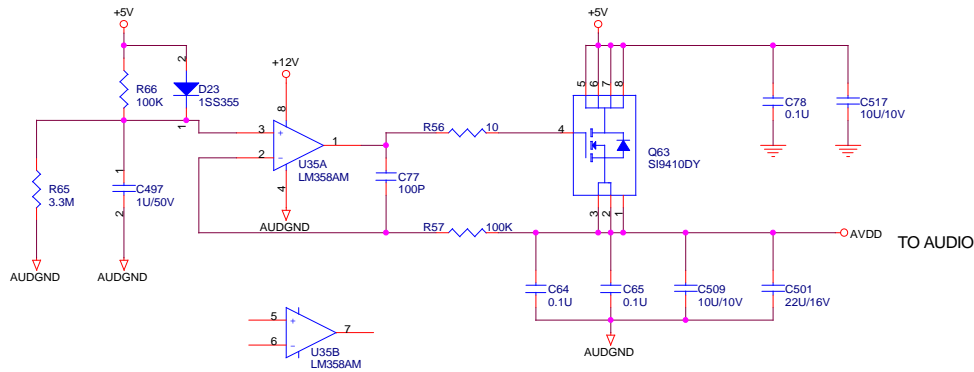

 QUANTA COMPUTER		
Size: Custom	Document Number: Z12	Rev: 3A
Date: Friday, July 25, 2003	Sheet: 23	of 38

Dr-Bios.com

AC97 CODEC

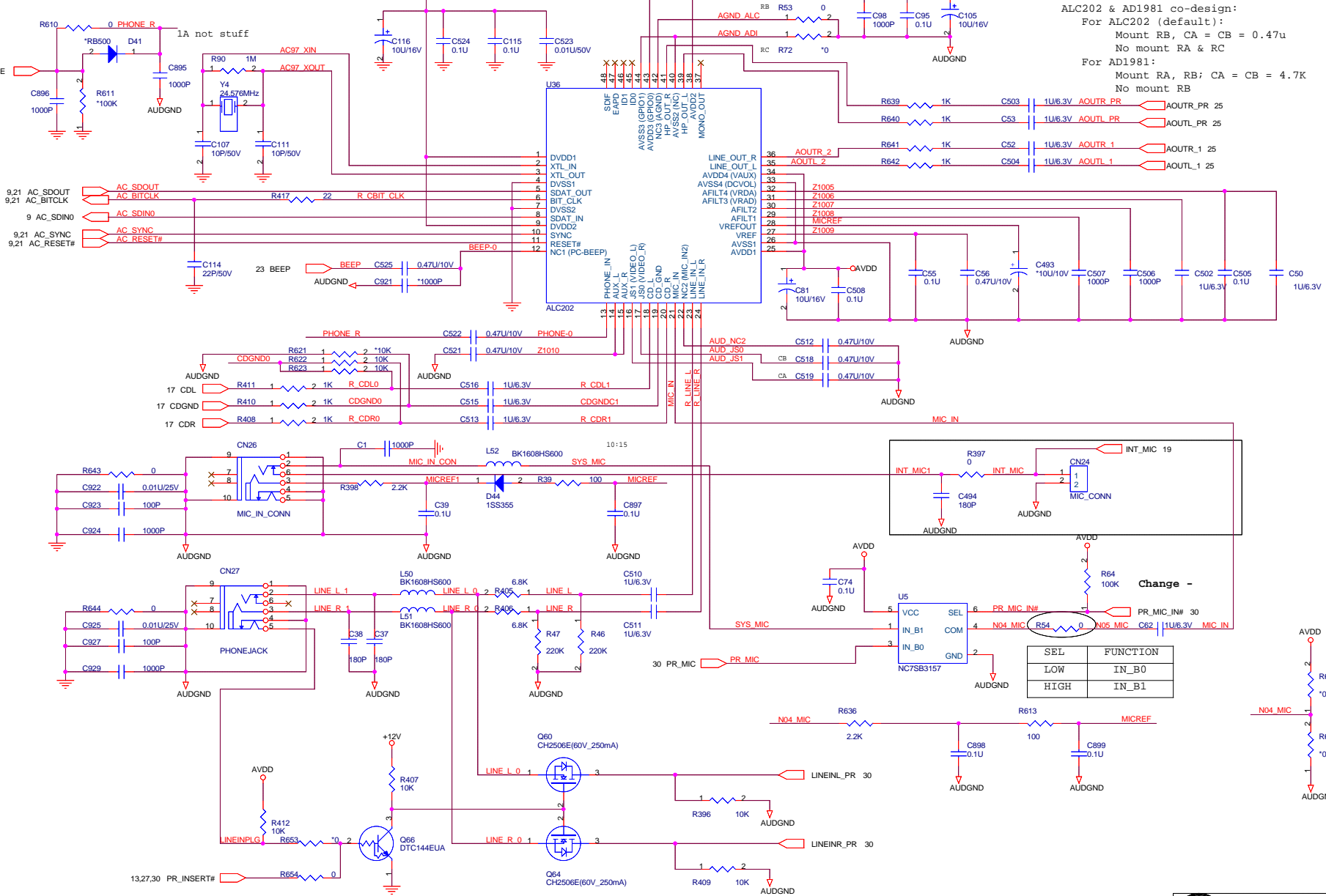

ALC202 & AD1981 co-design:
 For ALC202 (default):
 Mount RB, CA = CB = 0.47u
 No mount RA & RC
 For AD1981:
 Mount RA, RB; CA = CB = 4.7K
 No mount RB

SEL	FUNCTION
LOW	IN_B0
HIGH	IN_B1

Spec Change 10/02

Dr-Bios.com

QUANTA COMPUTER

Title: **ACP7 CODEC**

Size	Document Number	Rev
Customer	Z12	3B
Date:	Friday, July 25, 2003	Sheet 24 of 38

Audio Amplifier

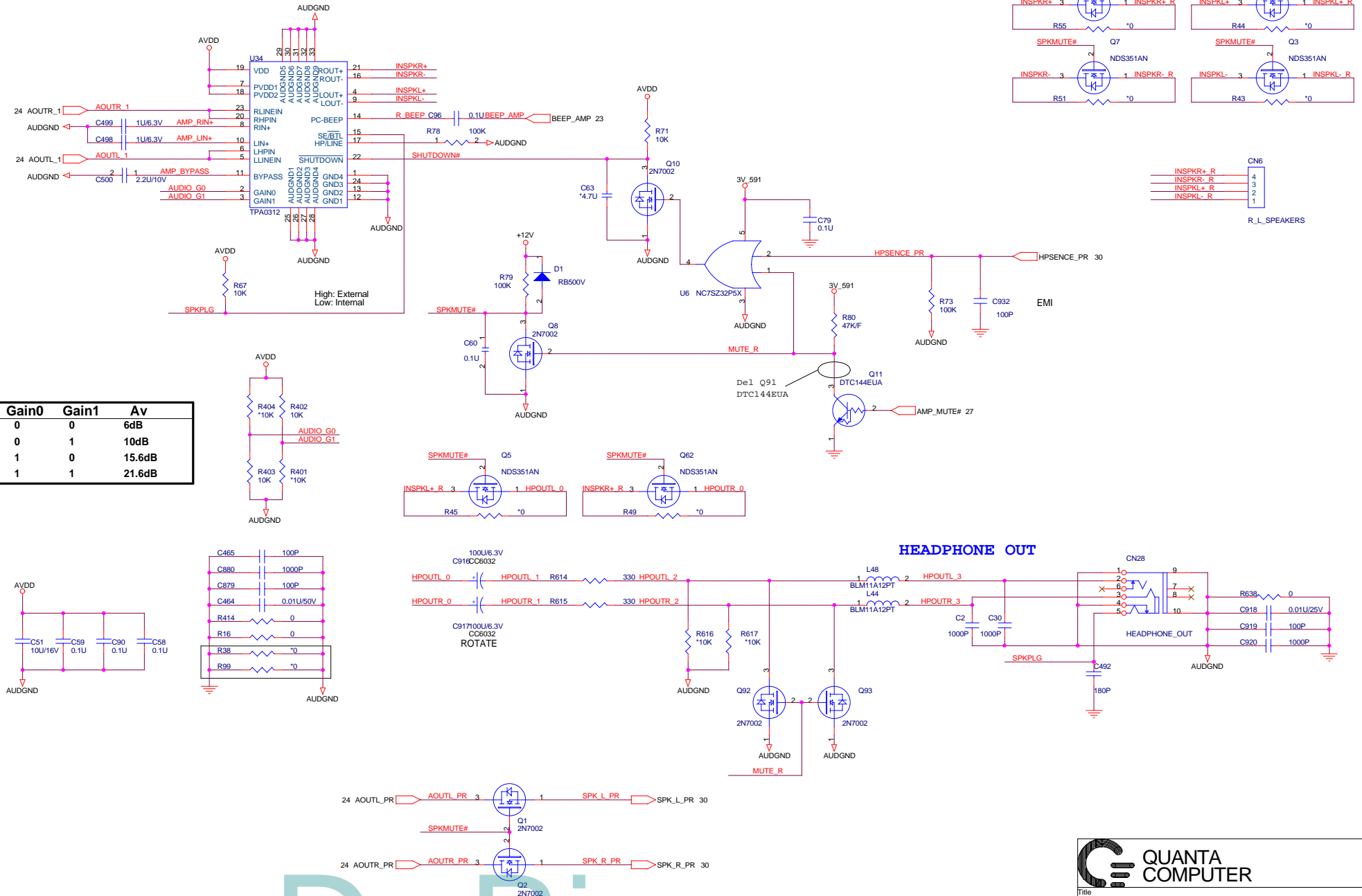

Gain0	Gain1	Av
0	0	6dB
0	1	10dB
1	0	15.6dB
1	1	21.6dB

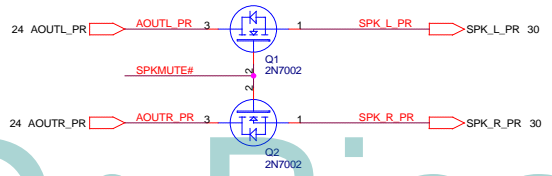
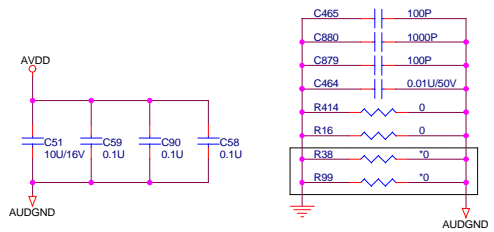
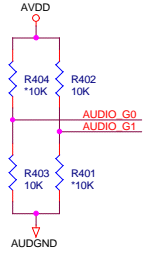



QUANTA COMPUTER

Title		
AUDIO AMP		
Size	Document Number	Rev
Custom	Z12	3B
Date:	Friday, July 25, 2003	Sheet 25 of 38

Dr-Bios.com

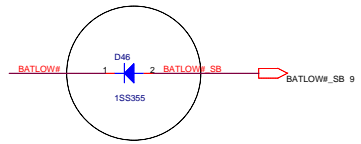

LDRQ#(pin 8) internal is no use

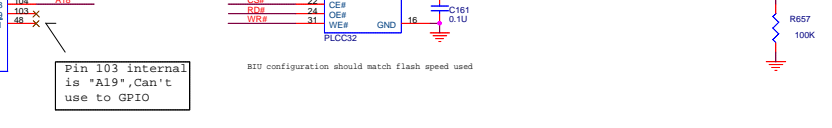
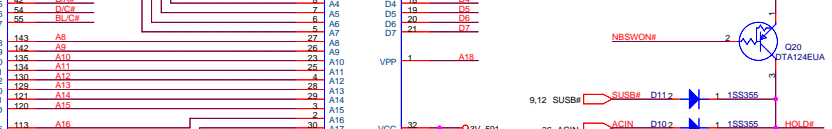
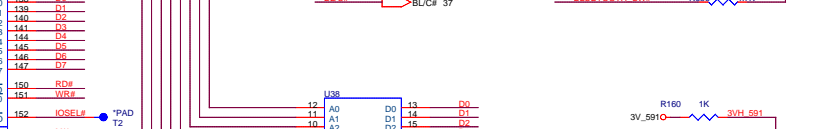
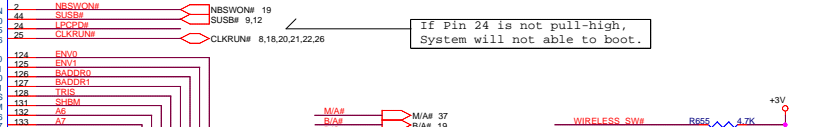
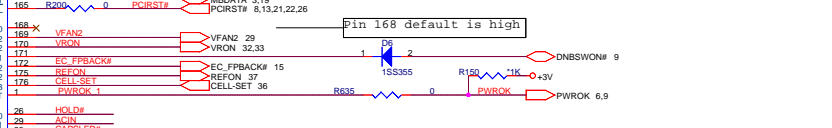
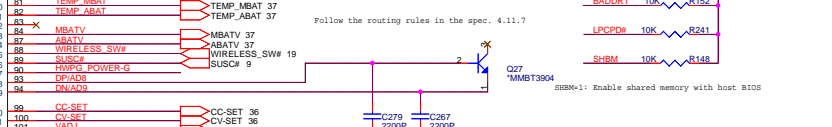
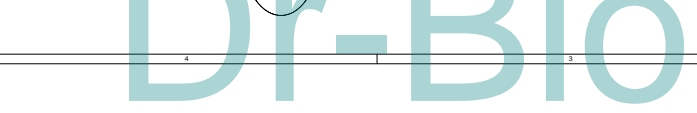
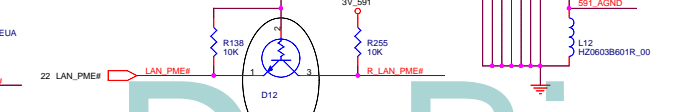
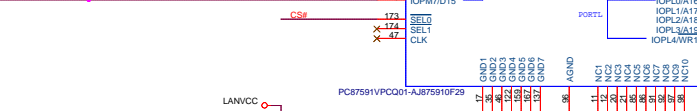
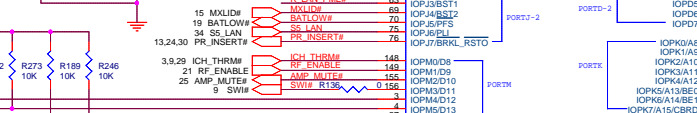
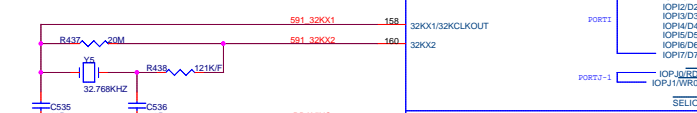
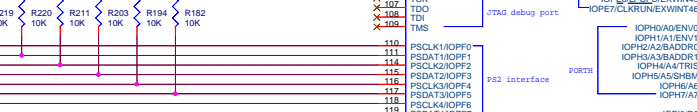
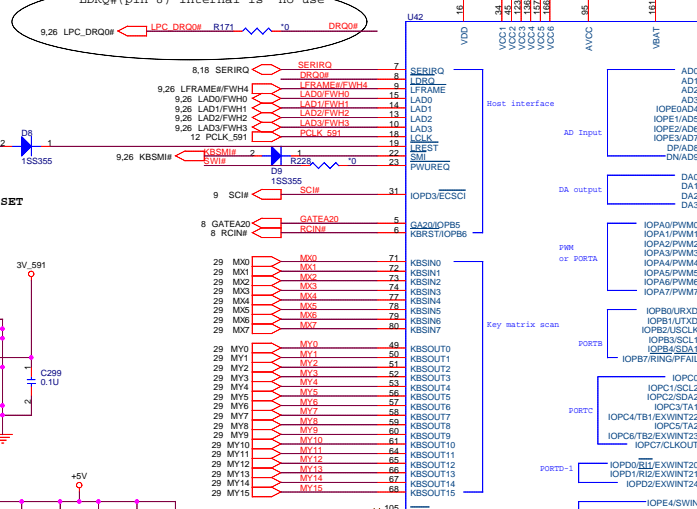
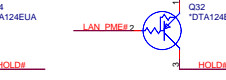
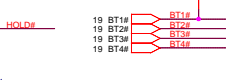
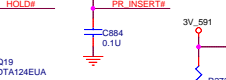
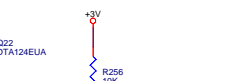
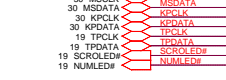
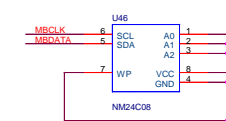
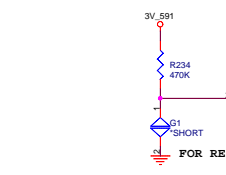

Should have a 0.1uF capacitor close to every GND-VCC pair + one larger cap on the supply.

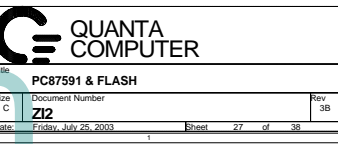
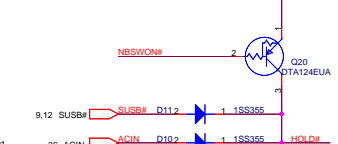
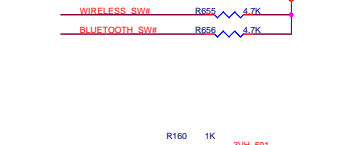
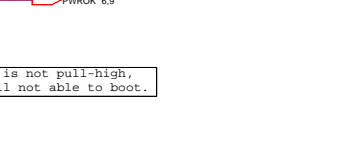
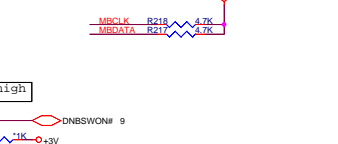
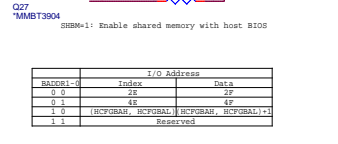
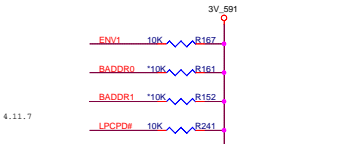

Backbit	Index	Index	Index
0	0	25	25
0	3	48	48
1	0	ICP0BAR, ICP1BAR, ICP2BAR, ICP3BAR, ICP4BAR, ICP5BAR, ICP6BAR, ICP7BAR, ICP8BAR, ICP9BAR, ICP10BAR, ICP11BAR, ICP12BAR, ICP13BAR, ICP14BAR, ICP15BAR, ICP16BAR, ICP17BAR, ICP18BAR, ICP19BAR, ICP20BAR, ICP21BAR, ICP22BAR, ICP23BAR, ICP24BAR, ICP25BAR, ICP26BAR, ICP27BAR, ICP28BAR, ICP29BAR, ICP30BAR, ICP31BAR, ICP32BAR, ICP33BAR, ICP34BAR, ICP35BAR, ICP36BAR, ICP37BAR, ICP38BAR, ICP39BAR, ICP40BAR, ICP41BAR, ICP42BAR, ICP43BAR, ICP44BAR, ICP45BAR, ICP46BAR, ICP47BAR, ICP48BAR, ICP49BAR, ICP50BAR, ICP51BAR, ICP52BAR, ICP53BAR, ICP54BAR, ICP55BAR, ICP56BAR, ICP57BAR, ICP58BAR, ICP59BAR, ICP60BAR, ICP61BAR, ICP62BAR, ICP63BAR, ICP64BAR, ICP65BAR, ICP66BAR, ICP67BAR, ICP68BAR, ICP69BAR, ICP70BAR, ICP71BAR, ICP72BAR, ICP73BAR, ICP74BAR, ICP75BAR, ICP76BAR, ICP77BAR, ICP78BAR, ICP79BAR, ICP80BAR, ICP81BAR, ICP82BAR, ICP83BAR, ICP84BAR, ICP85BAR, ICP86BAR, ICP87BAR, ICP88BAR, ICP89BAR, ICP90BAR, ICP91BAR, ICP92BAR, ICP93BAR, ICP94BAR, ICP95BAR, ICP96BAR, ICP97BAR, ICP98BAR, ICP99BAR	Reserved
1	1	Reserved	Reserved

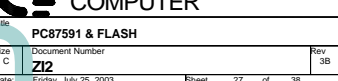
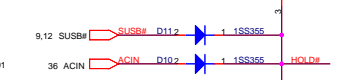
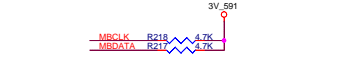

QUANTA COMPUTER

Title: **PC87591 & FLASH**

Size: C Document Number: **Z12** Rev: 3B

Date: Friday, July 25, 2003 Sheet: 27 of 38

Dr-Bios.com

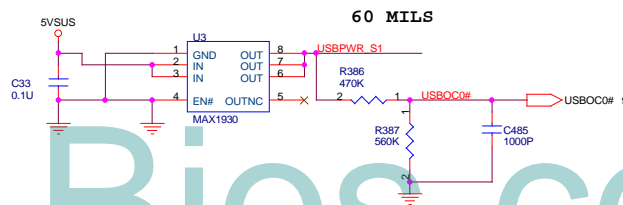
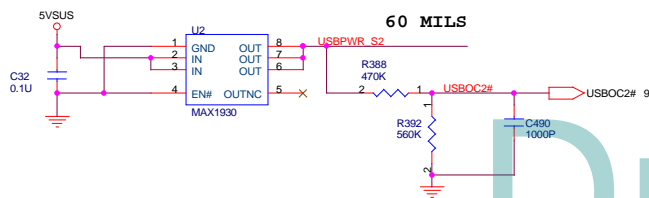
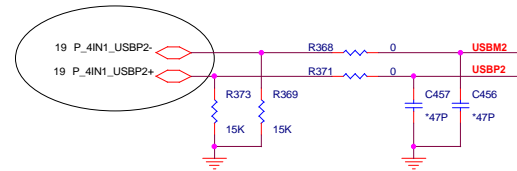
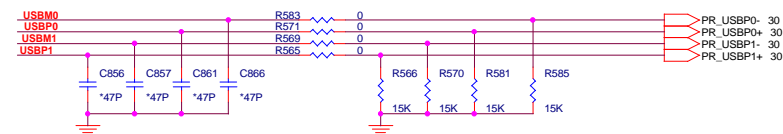
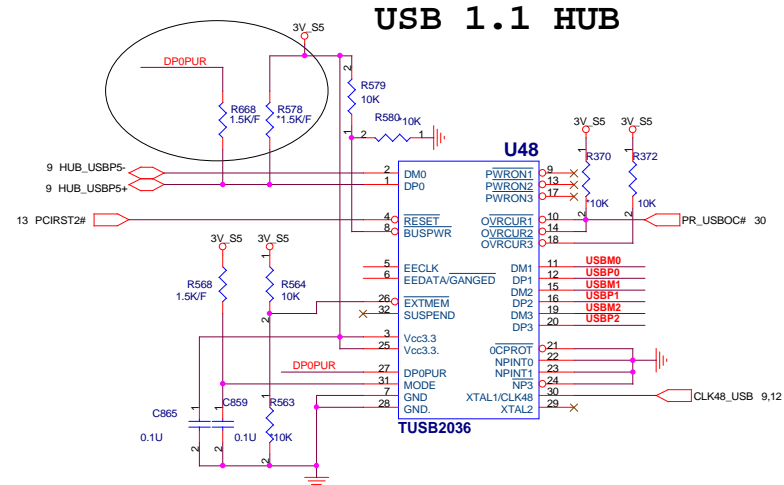
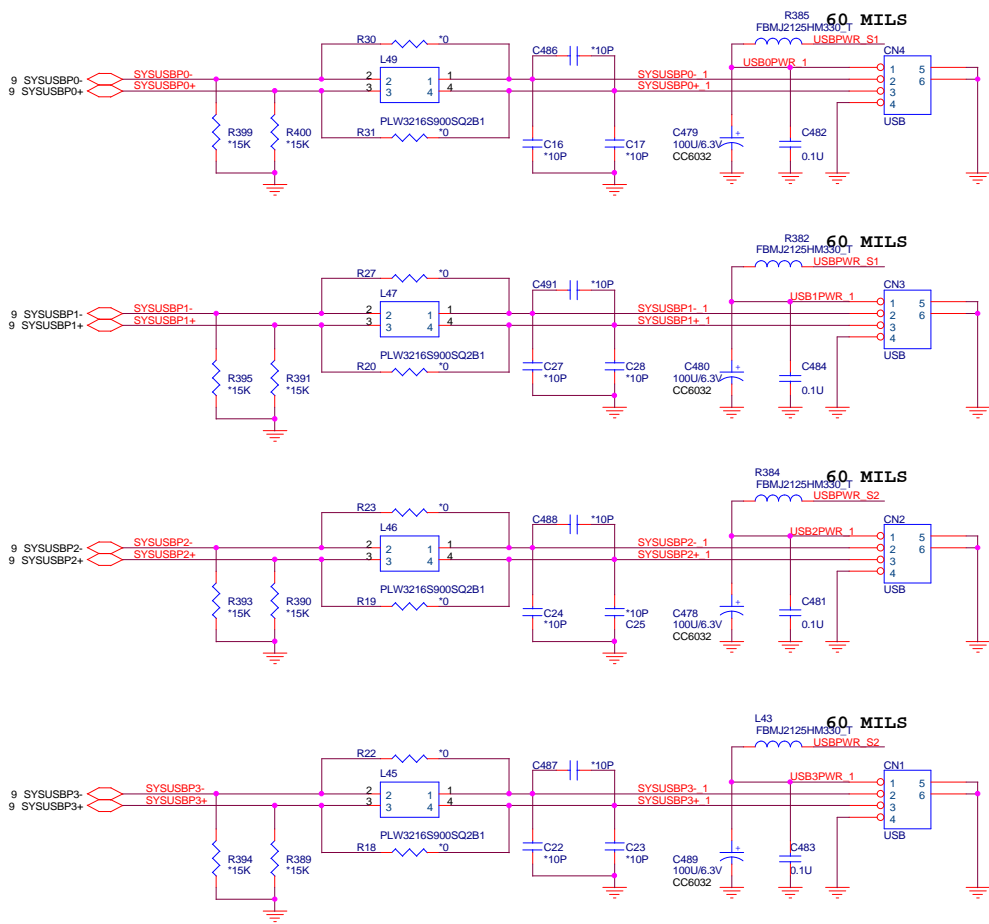

Title		
USB CONN.		
Size	Document Number	Rev
Custom	Z12	3E
Date:	Friday, July 25, 2003	Sheet 28 of 38

Dr-Bios.com

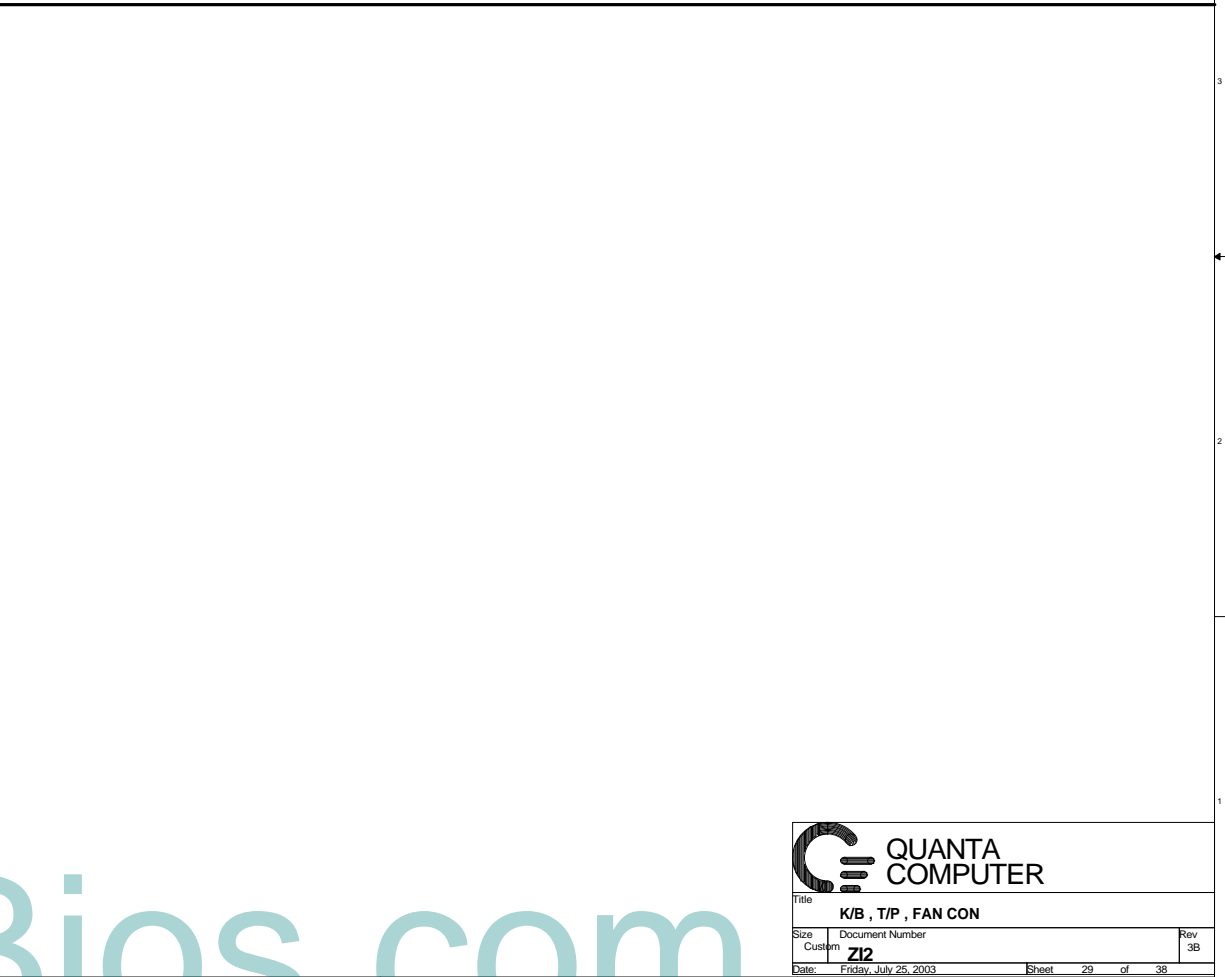
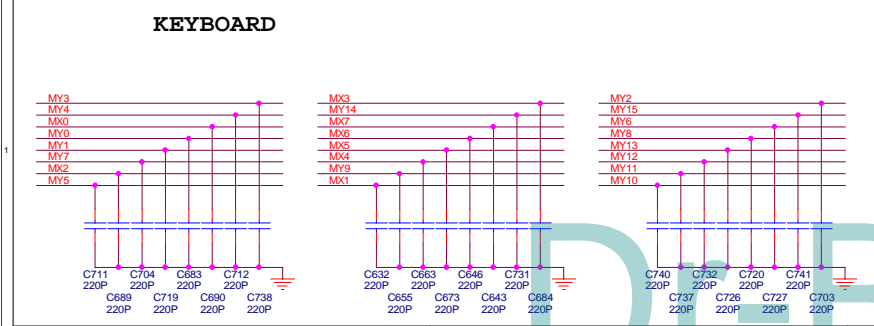
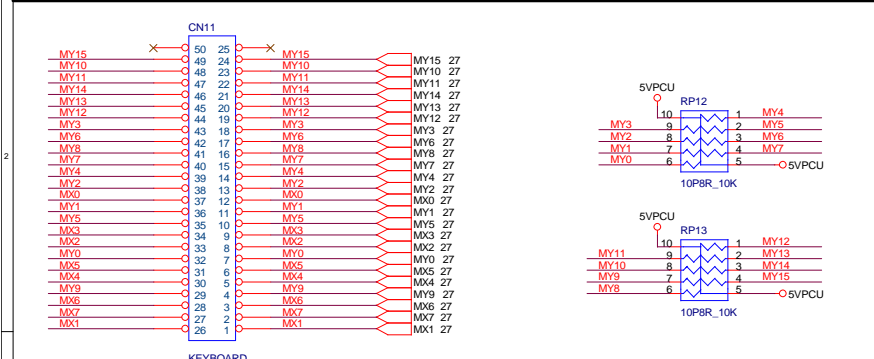
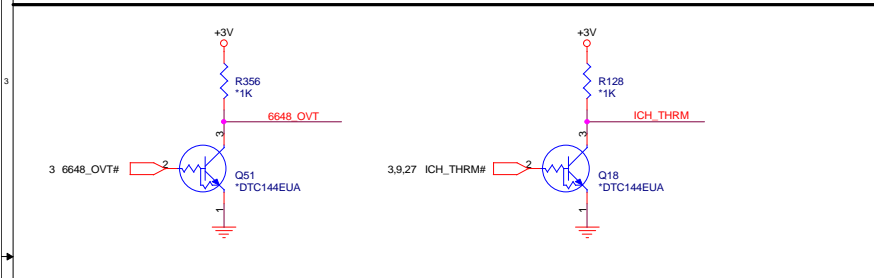
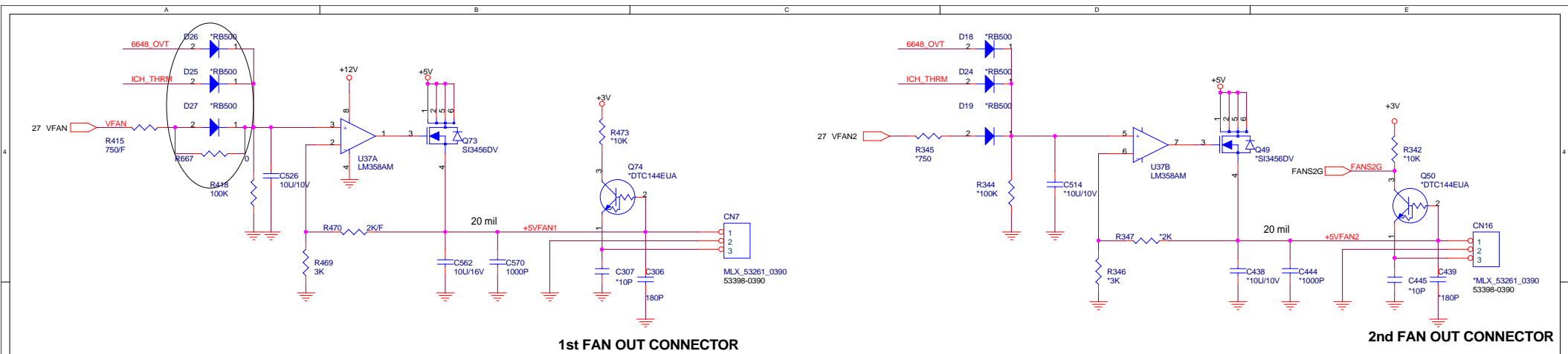

QUANTA COMPUTER

Title: **K/B , T/P , FAN CON**

Size: Custom
 Document Number: **Z12**
 Date: Friday, July 25, 2003

Rev: 3B

Sheet: 29 of 38

DIPBios.com

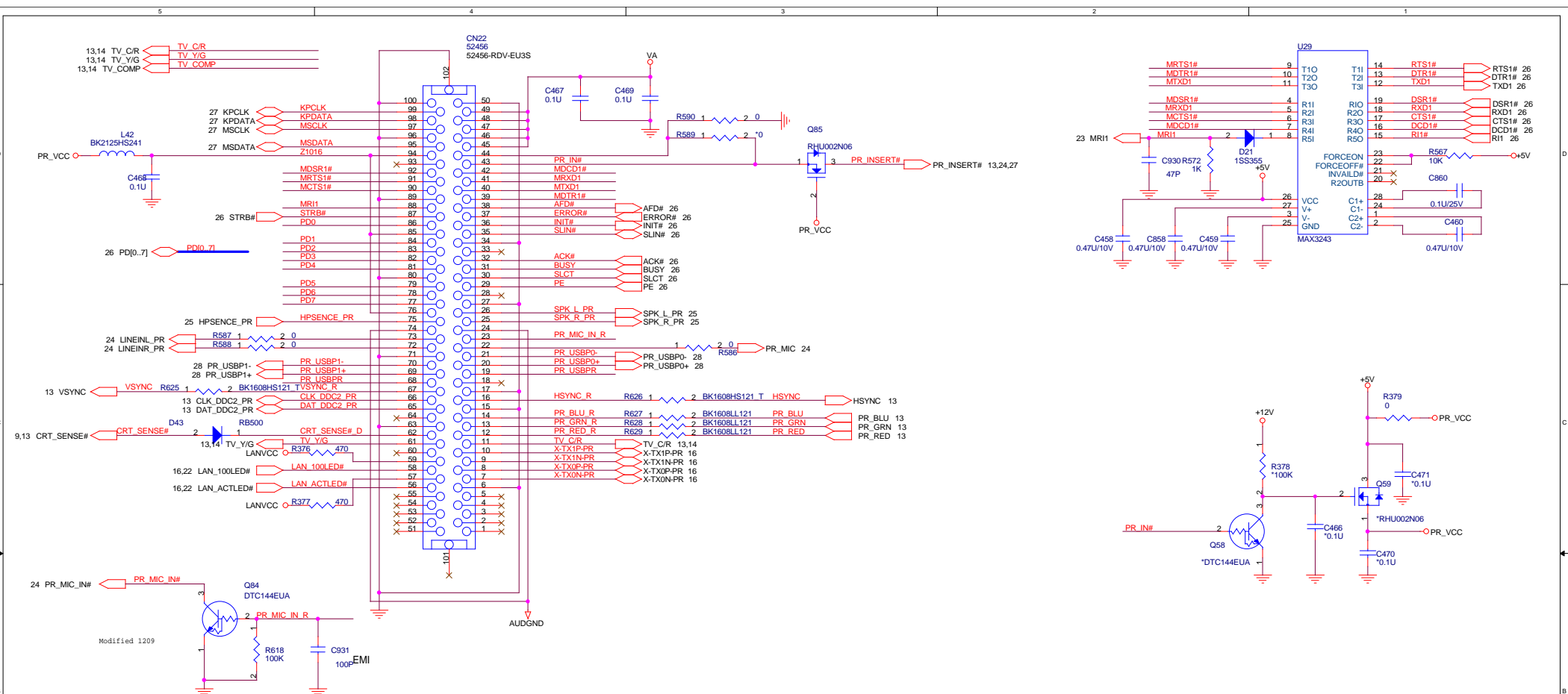

PR_MIC_IN#	C900	*100P
PR_MIC	C901	47P
LAN_100LED#	C902	1000P
LAN_ACTLED#	C903	*1000P
TV_C/R	C904	*22P
TV_Y/G	C905	10P/50V
CLK_DDC2_PR	C906	10P
DAT_DDC2_PR	C907	10P
KPCLK	C908	47P
KPDATA	C909	47P
MSCLK	C910	47P
MSDATA	C911	47P

SPK_L_PR	C463	220P
SPK_R_PR	C462	220P
LINEINL_PR	C885	220P
LINEINR_PR	C886	220P
PR_USBPO-	C878	10P/50V
PR_USBPO+	C881	10P/50V
PR_USBPR-	C883	10P/50V
PR_USBPR+	C882	10P/50V
PR_BLU_R	C872	*10P
PR_GRN_R	C874	*10P
PR_RED_R	C873	*10P
HSYNC_R	C875	*10P
VSYNC_R	C877	*10P
CRT_SENSE#	C876	10P
X-TX1P-PR	C871	10P
X-TX1N-PR	C867	10P
X-TX0P-PR	C869	10P
X-TX0N-PR	C870	10P

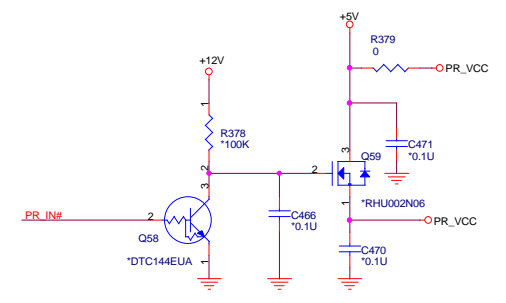
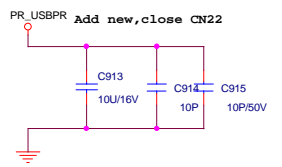
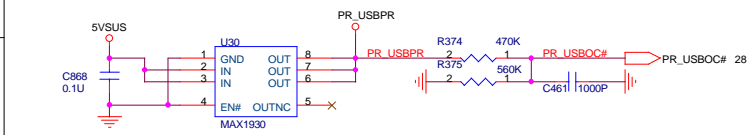

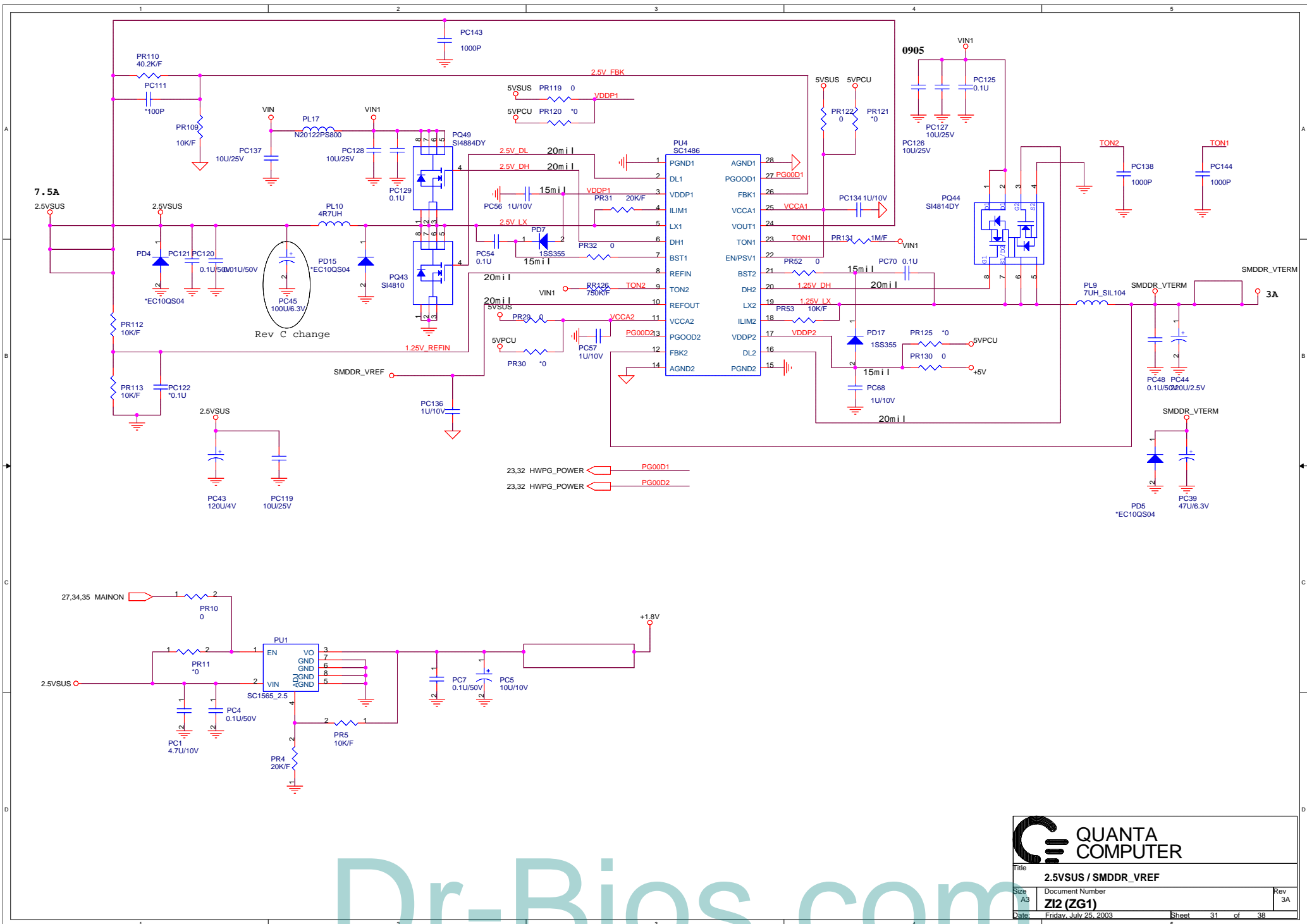

Dr-Bios.com

QUANTA COMPUTER

Title	2.5VSUS / SMDR_VREF	
Size	Document Number	Rev
A3	Z12 (ZG1)	3A
Date	Friday, July 25, 2003	Sheet 31 of 38

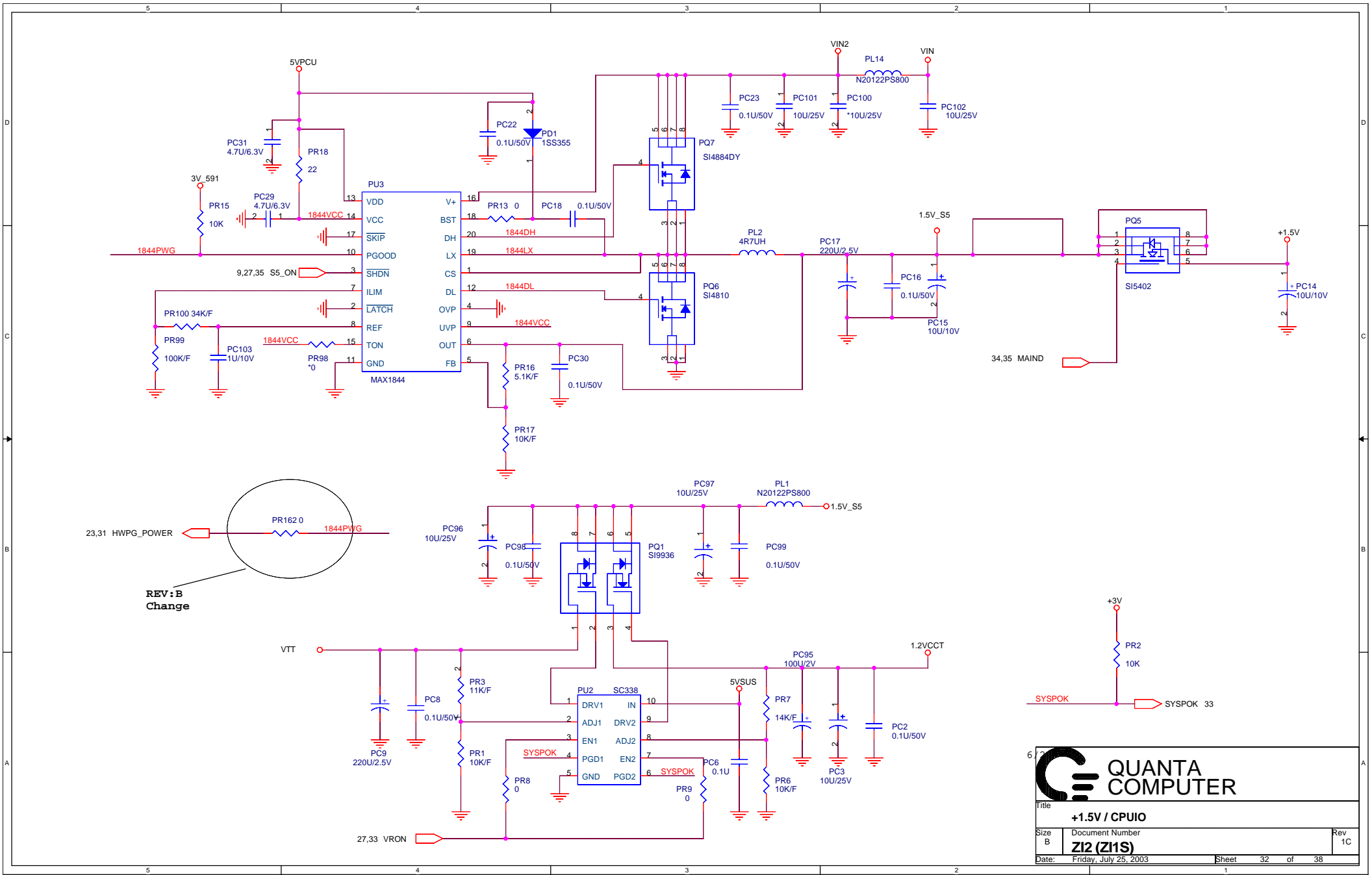

Dr-Bios.com

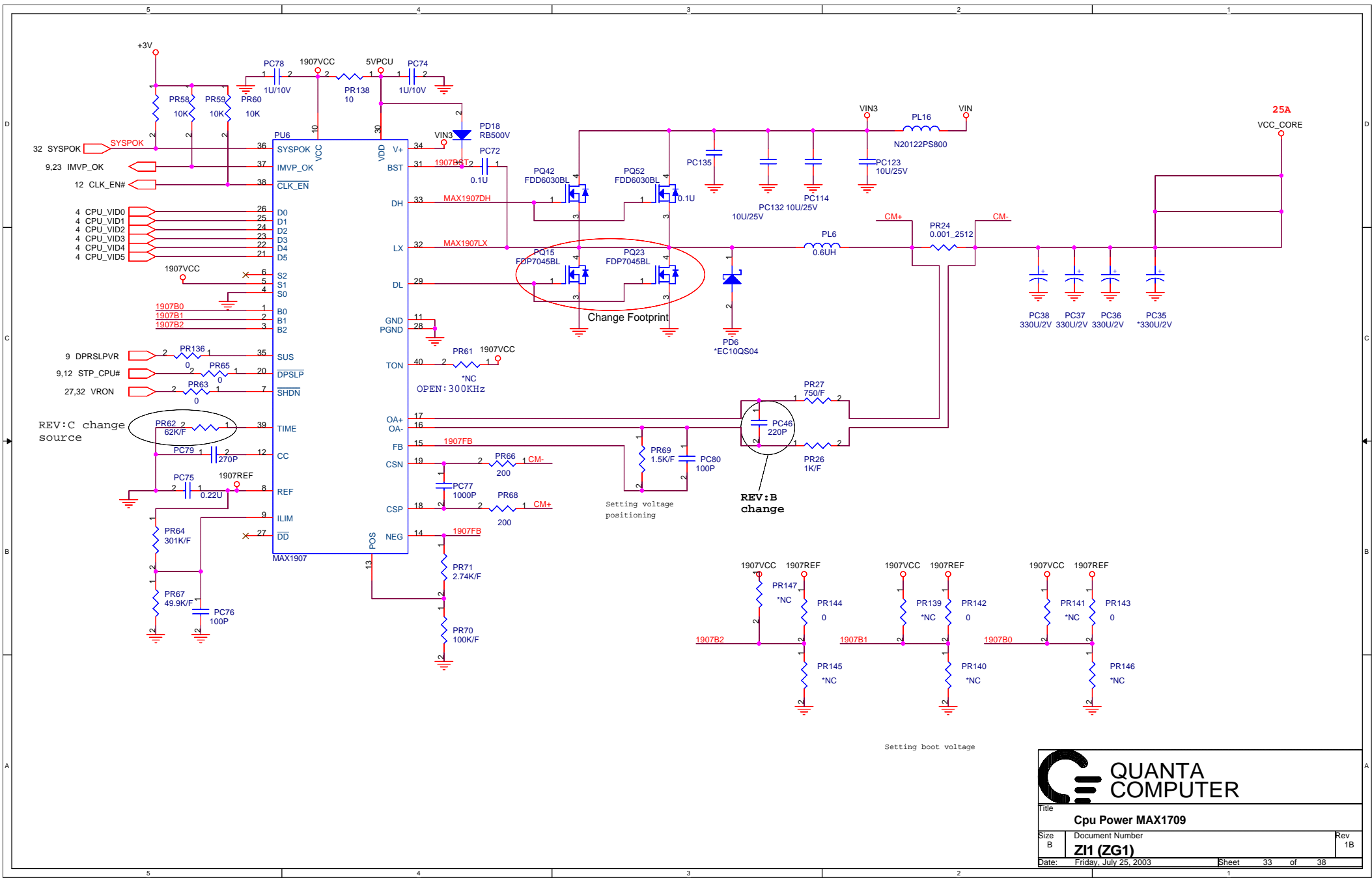

QUANTA COMPUTER

Title: **Cpu Power MAX1709**

Size B	Document Number	Rev 1B
Z11 (ZG1)		
Date: Friday, July 25, 2003	Sheet 33 of 38	

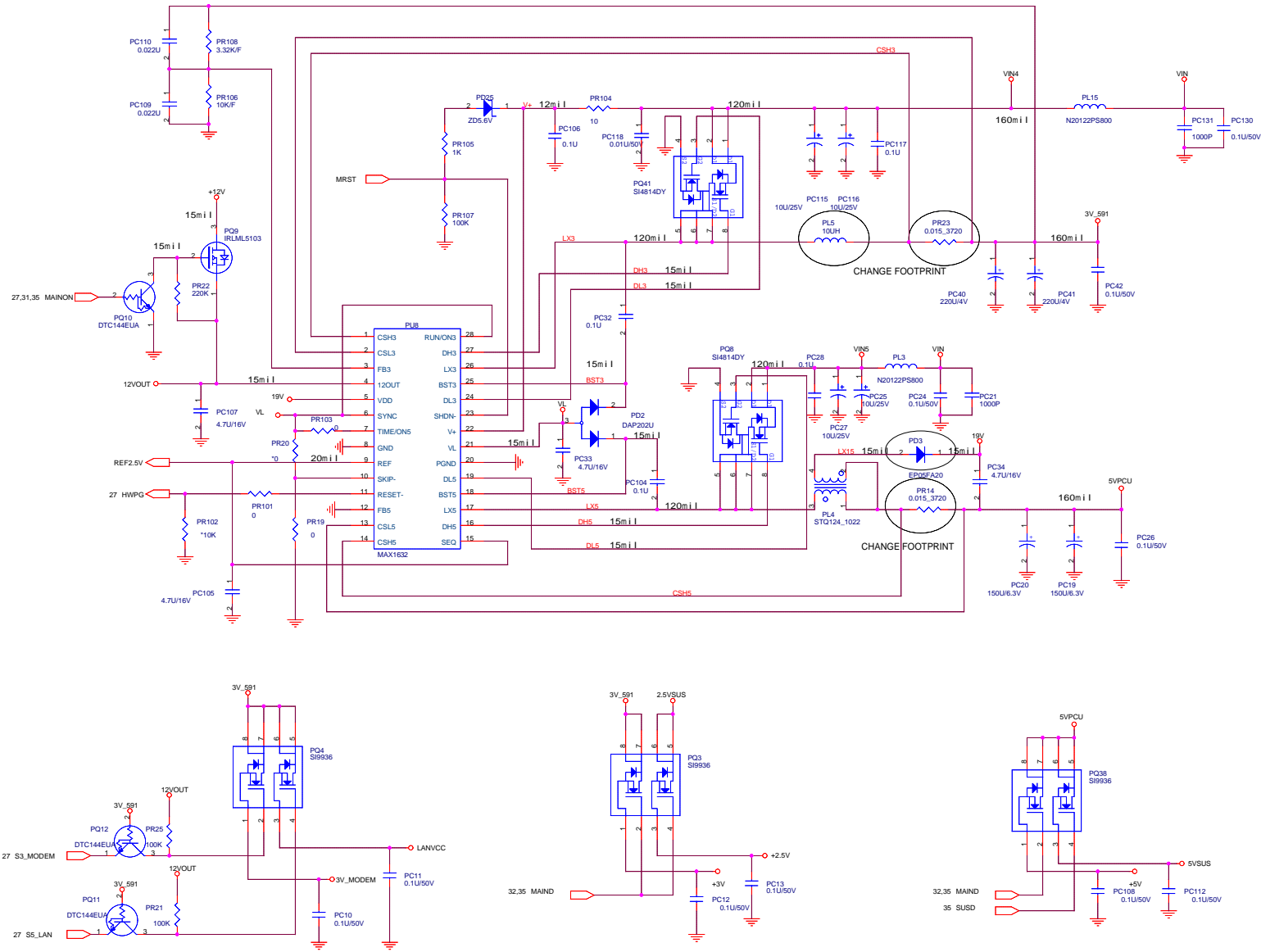

Dr-Bios.com

QUANTA COMPUTER

Title: **System Power 1632**

Size: C Document Number: **Z12 (ZG1)** Rev: 1A

Date: Friday, July 25, 2003 Sheet: 34 of 38

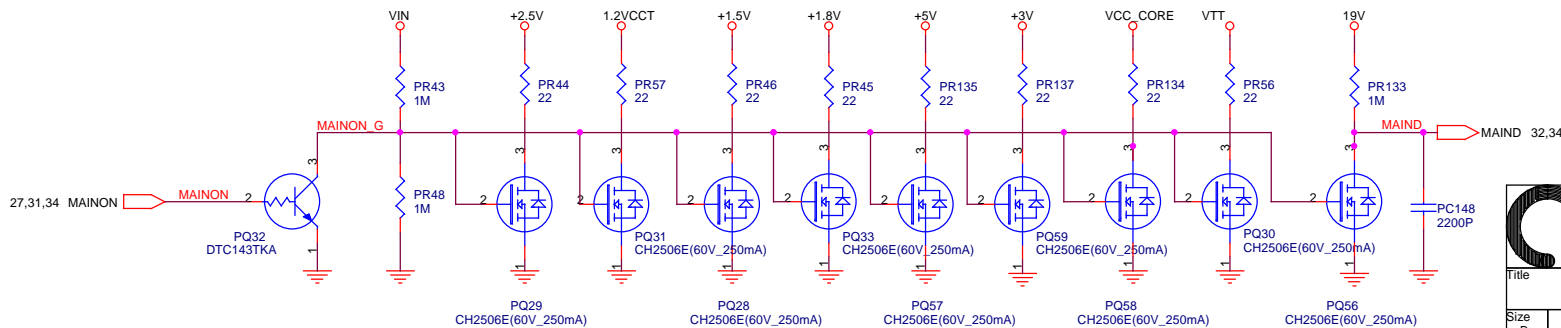
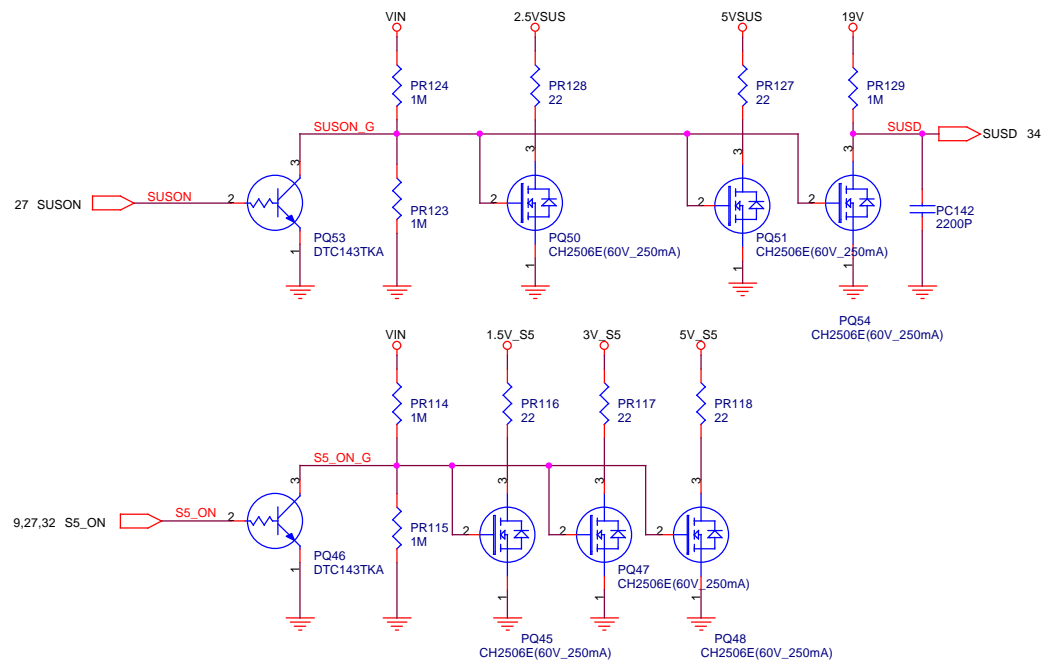
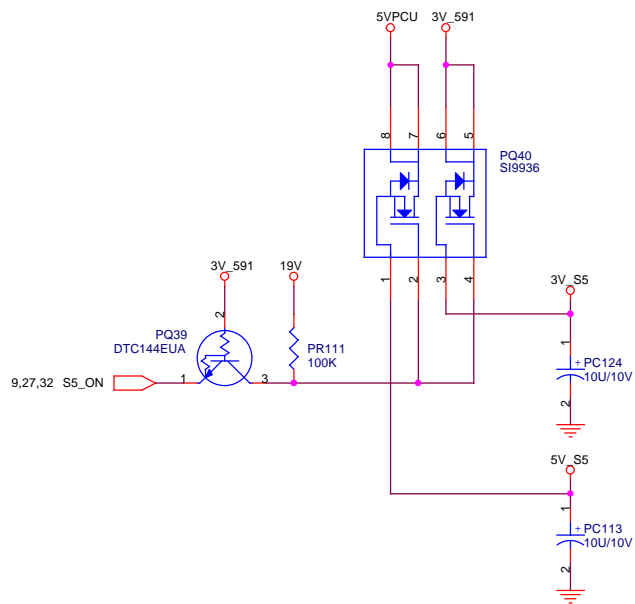

Title		
Discharge Circuit		
Size B	Document Number	Rev 3B
Z12 (ZG1)		
Date: Friday, July 25, 2003	Sheet 35 of 38	

Dr-Bios.com

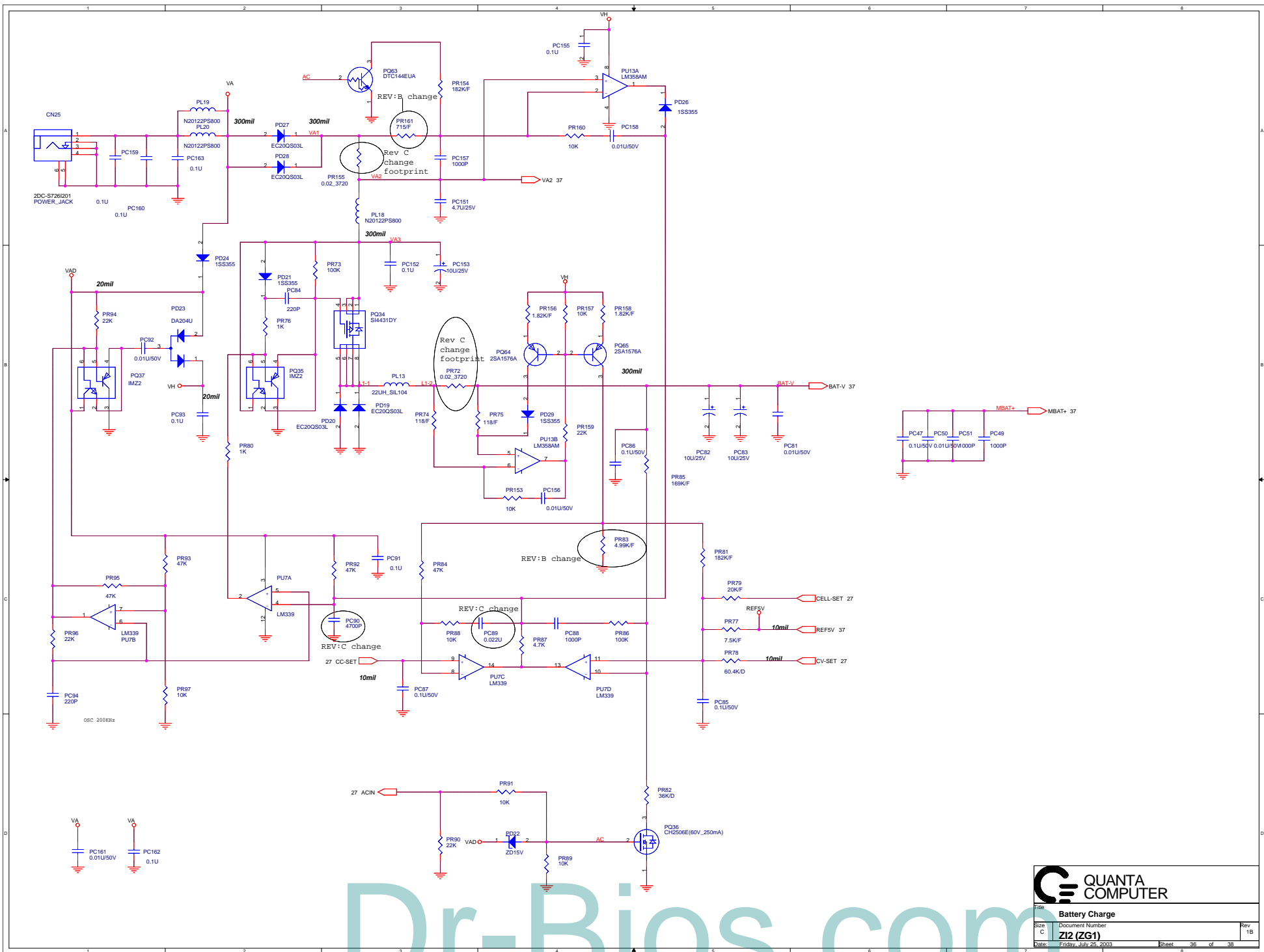

Dr-Bios.com

QUANTA COMPUTER

Battery Charge

Size: C Document Number: **Z12 (ZG1)** Rev: 1B

Date: Friday, July 25, 2003 Sheet: 36 of 38

1ST_BATT_CONN

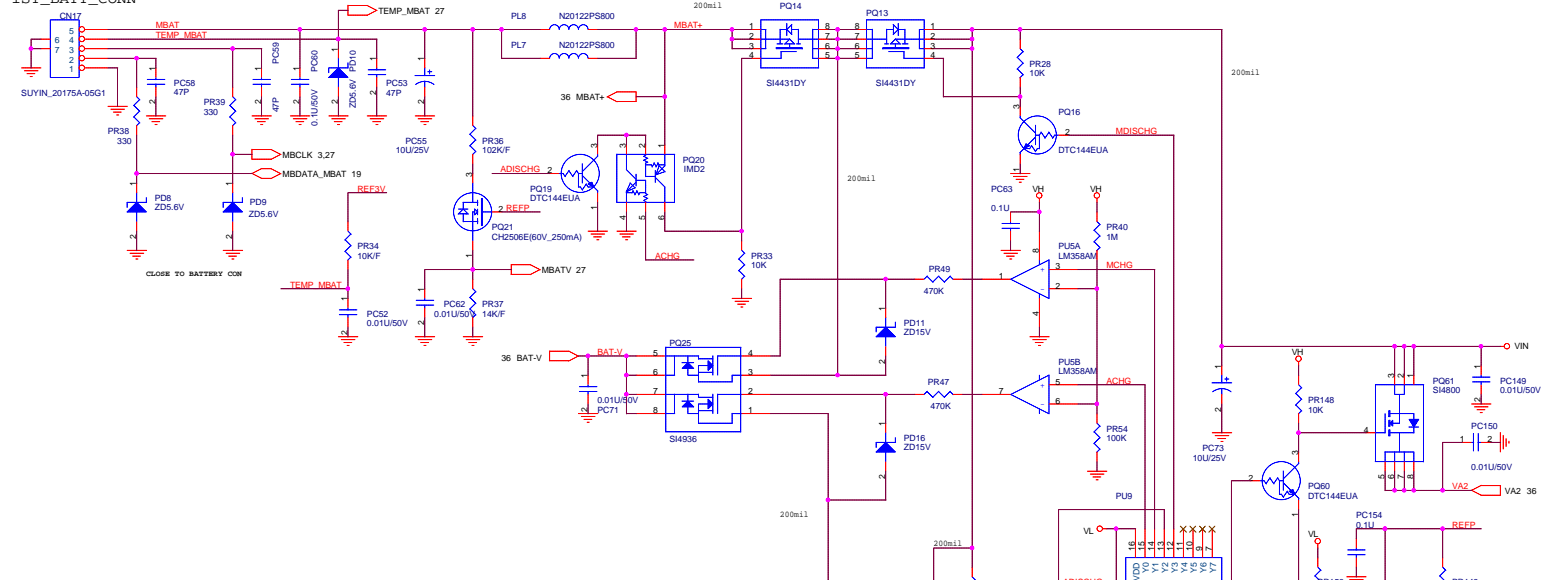

2ND_BATT_CONN

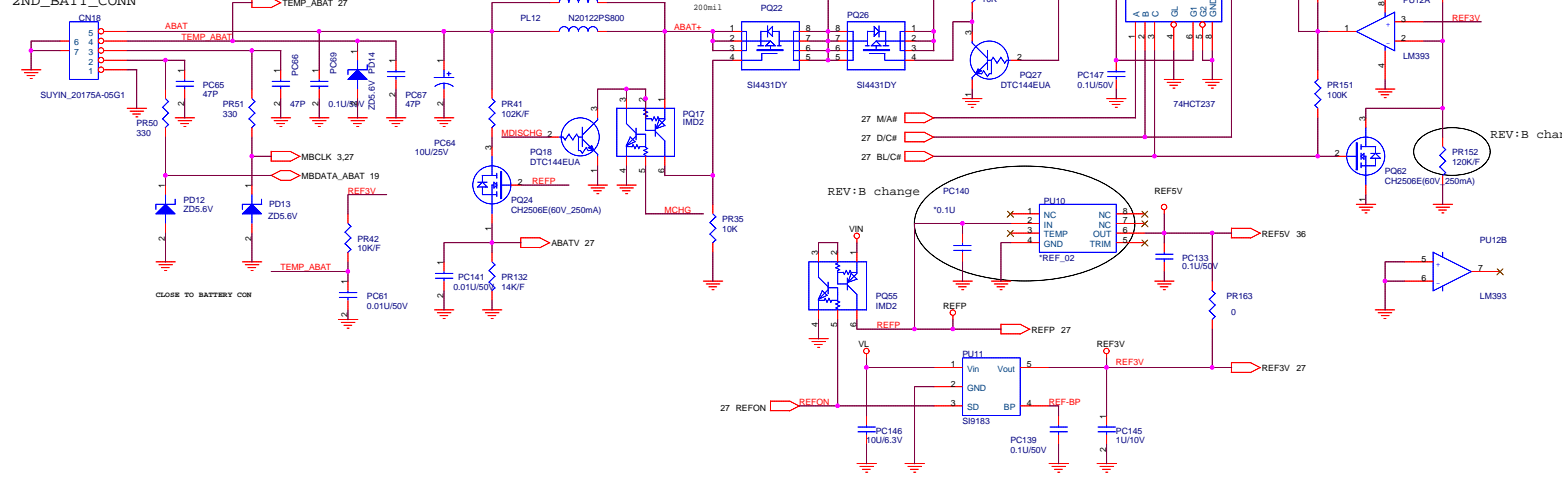

Title		Battery Select	
Size	C	Document Number	Z12 (ZG1)
Date	Friday, July 25, 2003	Sheet	37 of 38

Dr-Bios.com