

KiliManjaro

CS Build(A02)

2008.02.04

www.kyuthuatvithinh.com

DATE	CHANGE NO.	REV

DRAWER	EE	DATE	POWER	DATE	INVENTEC					
DESIGN					TITLE <i>KiliManjaro</i>					
CHECK					SIZE = 3					
RESPONSIBLE					FILE NAME: XXXX-XXXXXX-XX	VER:	SIZE A3	CODE CS	DOC. NUMBER	REV X01
					P/N: XXXXXXXXXXXX		SHEET	1	OF	58

TABLE OF CONTENTS

PAGE

MAINBOARD

- 1.COVER PAGE
- 2.INDEX
- 3.BLOCK DIAGRAM
- 4.POWER SEQUENCE BLOCK
- 5-12.SYSTEM POWER
- 13.CLOCK GENERATOR
- 14-17.CPU Merom
- 18.FAN & THERMAL CONTROLLER
- 19-25.N/B Calistoga
- 26.DDR2 DIMM0
- 27.DDR2 DIMM1
- 28.DDR DAMPING
- 29.MXM CONN
- 30.CRT CONN
- 31.HDMI CONN
- 32.LCD CONN
- 33-37.S/B ICH8
- 38.EXPRESS CARD

PAGE

- 39.CARD READER
- 40.LAN CONTROLLER
- 41.RJ45 & TRANSFORMER
- 42.MINI CARD CONN
- 43.ODD & HDD CONN
- 44.USB CONN
- 45.BT & LED & CIR & SW
- 46.KBC
- 47.CODEC
- 48-49.AUDIO AMP&JACK
- 50.MDC
- 51.SCREW & EMI
- 52.TO OTHER BOARD CONN

PAGE

SMALL BOARD

- 53.IO BOARD(TV Turner or Robson)
- 54.USB & TV BOARD
- 55.PWR JACK LED BOARD
- 56.PWR BUTTON & LID BOARD
- 57.E-KEY BOARD
- 58.TH-BUTTON BOARD
- 59.HOTKEY BOARD

INVENTEC

TITLE
KiliManjaro

SIZE A3	CODE CS	DOC. NUMBER <i>Model No</i>	REV X01
SHEET		2	OF 58

CHANGE by *Erison* *12-Dec-2007*

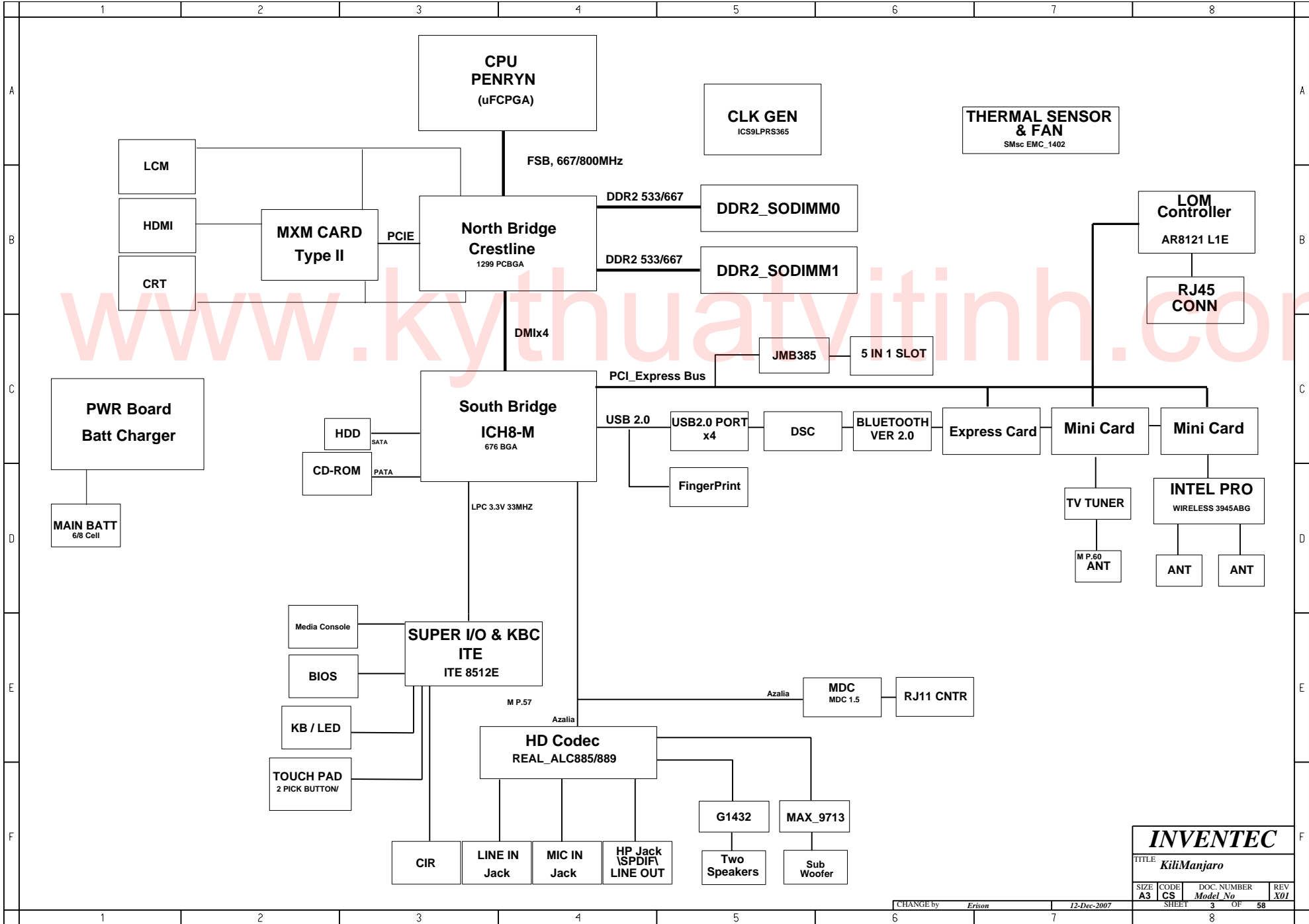

INVENTEC			
TITLE <i>KiliManjaro</i>			
SIZE A3	CODE CS	DOC. NUMBER <i>Model No</i>	REV X01
SHEET 3		OF 58	

CHANGE by *Erison* 12-Dec-2007

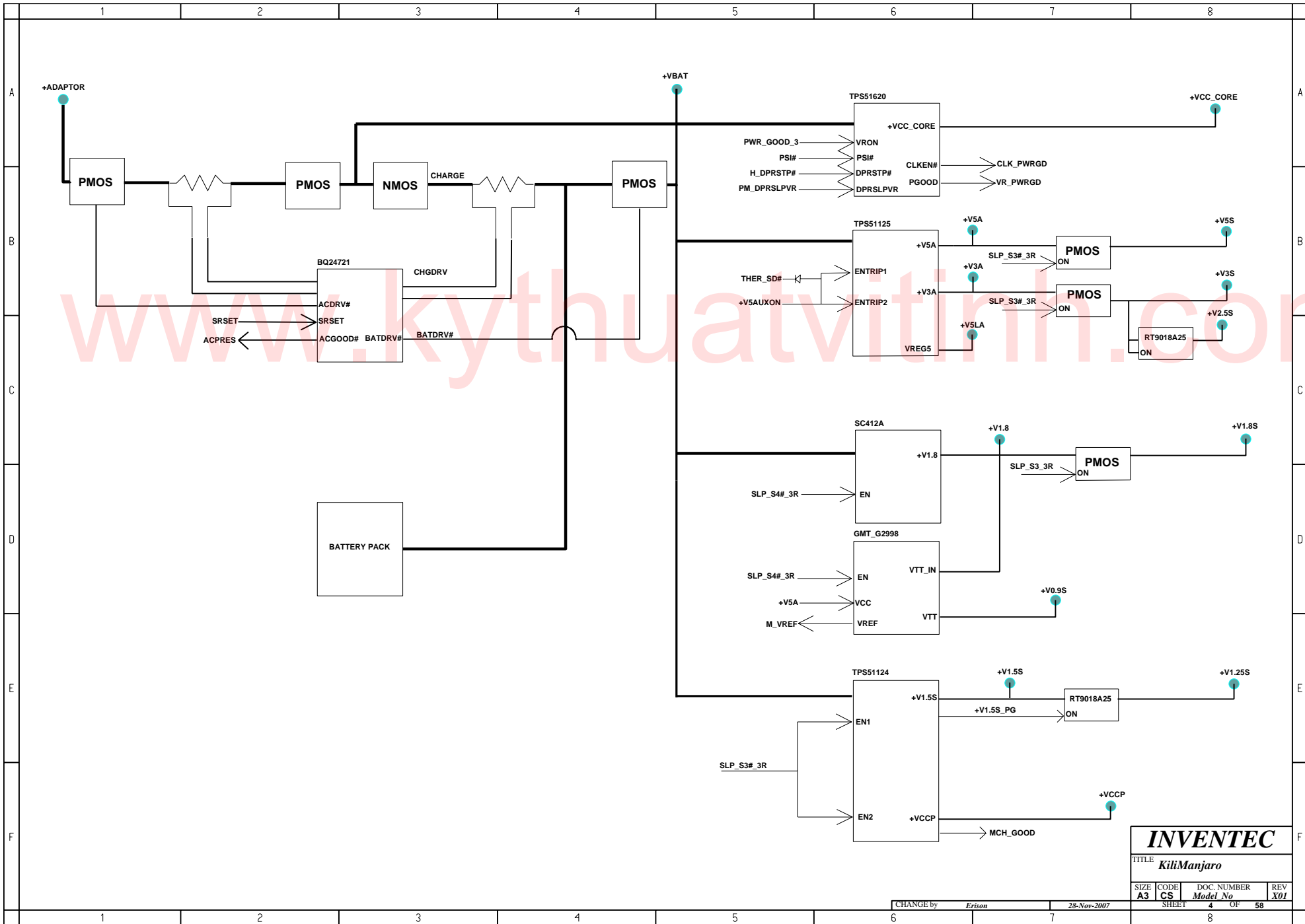

INVENTEC			
TITLE <i>KiliManjaro</i>			
SIZE A3	CODE CS	DOC. NUMBER <i>Model No</i>	REV X01
CHANGE by <i>Erison</i>		28-Nov-2007	
SHEET 4		OF 58	

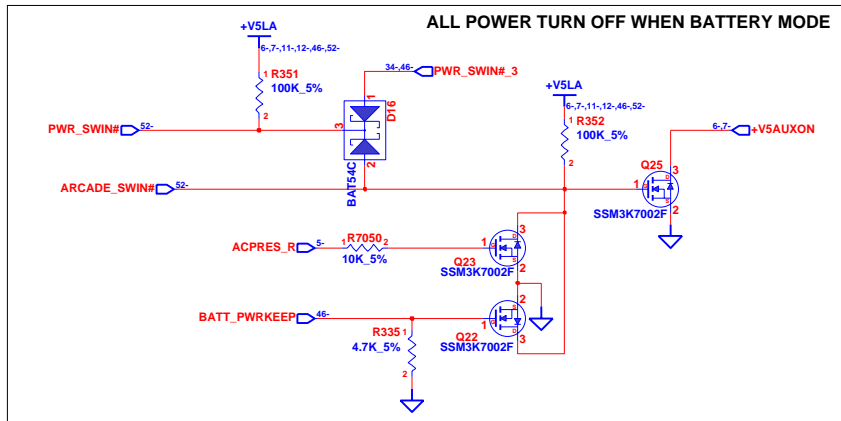
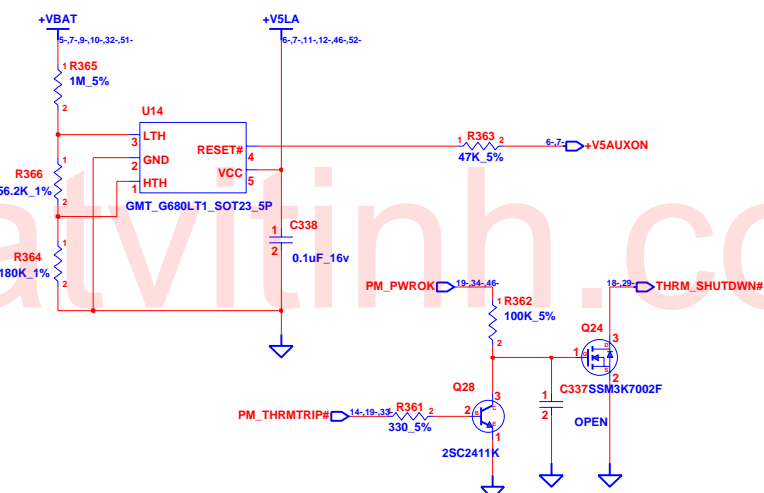
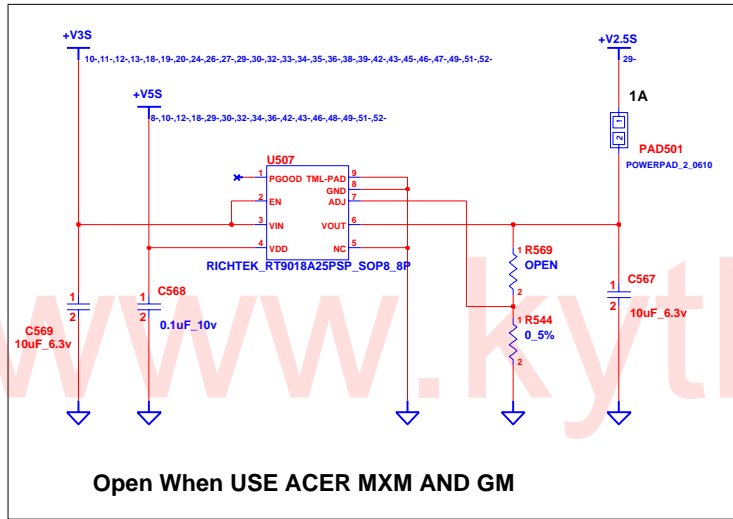

INVENTEC

TITLE			
KiliManjaro			
+V2.5S / RESET			
SIZE	CODE	DOC. NUMBER	REV
A3	CS	Model No	X01

CHANGE by Erison 10-Jan-2008

SHEET 6 OF 58

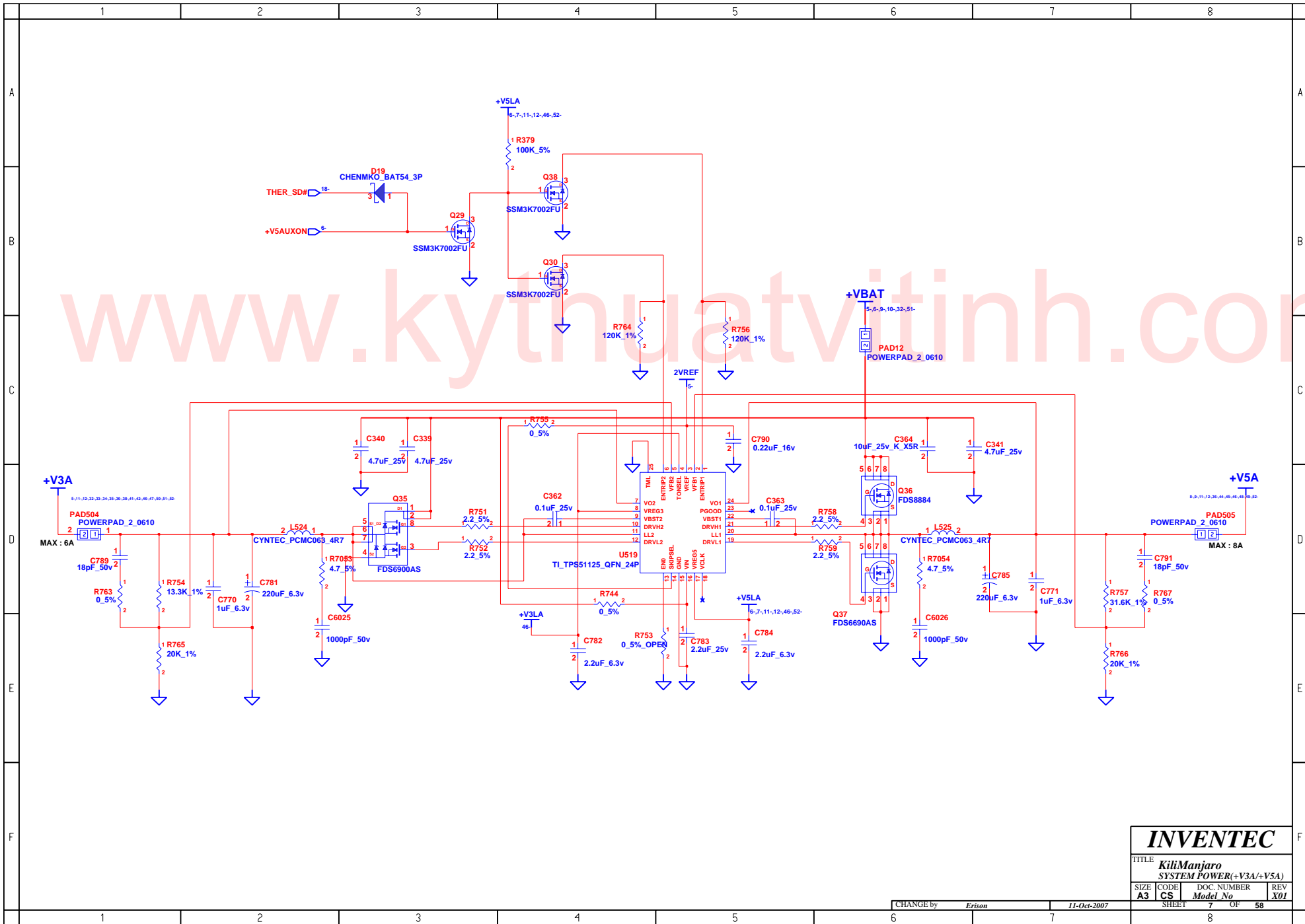

INVENTEC			
TITLE KiliManjaro SYSTEM POWER(+V3A/+V5A)			
SIZE A3	CODE CS	DOC NUMBER Model No	REV X01
CHANGE by <i>Erison</i>		11-Oct-2007	
SHEET 7		OF 58	

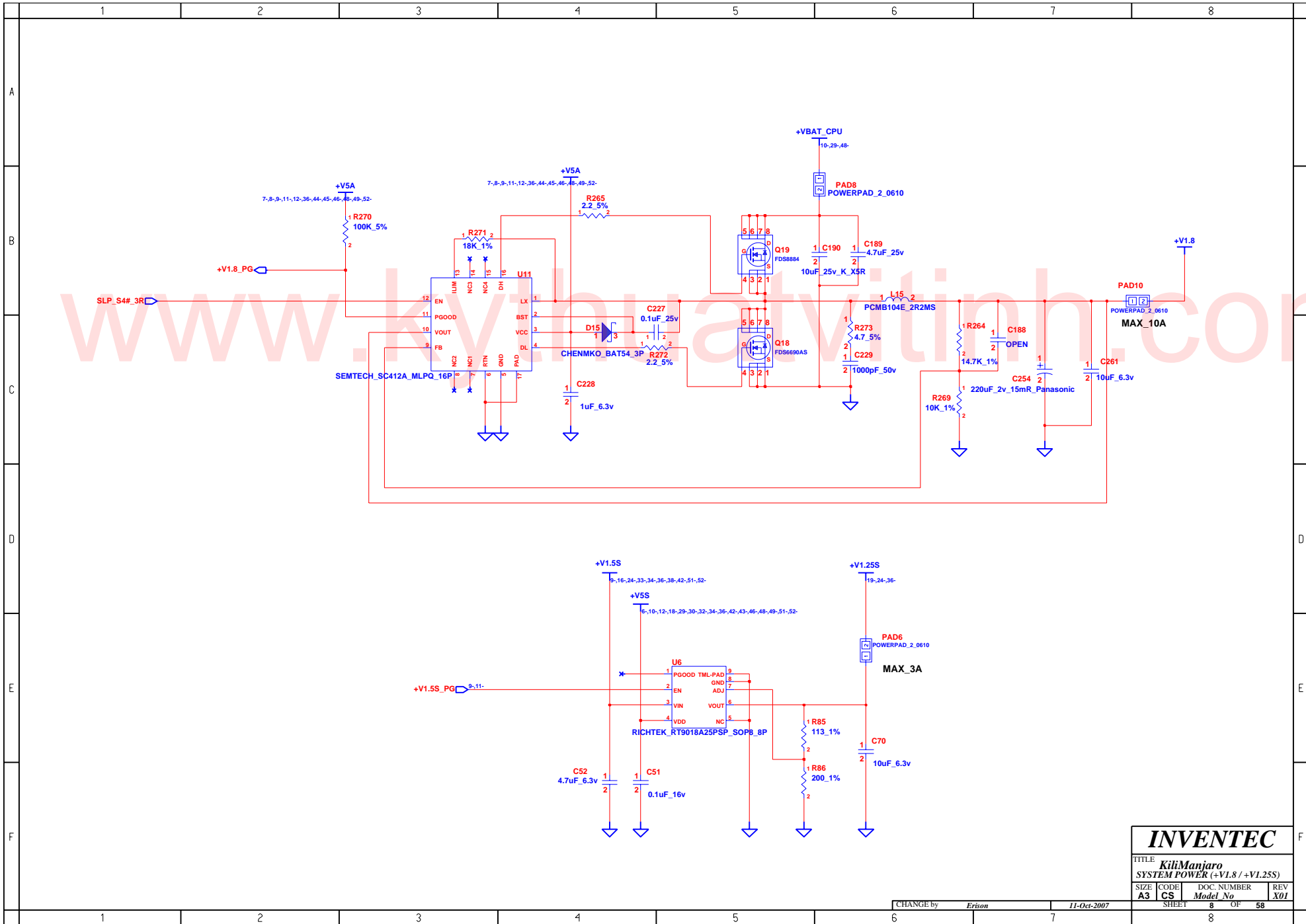

INVENTEC			
TITLE <i>KiliManjaro</i> SYSTEM POWER (+V1.8 / +V1.25S)			
SIZE A3	CODE CS	DOC. NUMBER Model No	REV X01
CHANGE by <i>Erison</i>		11-Oct-2007	
SHEET 8		OF 58	

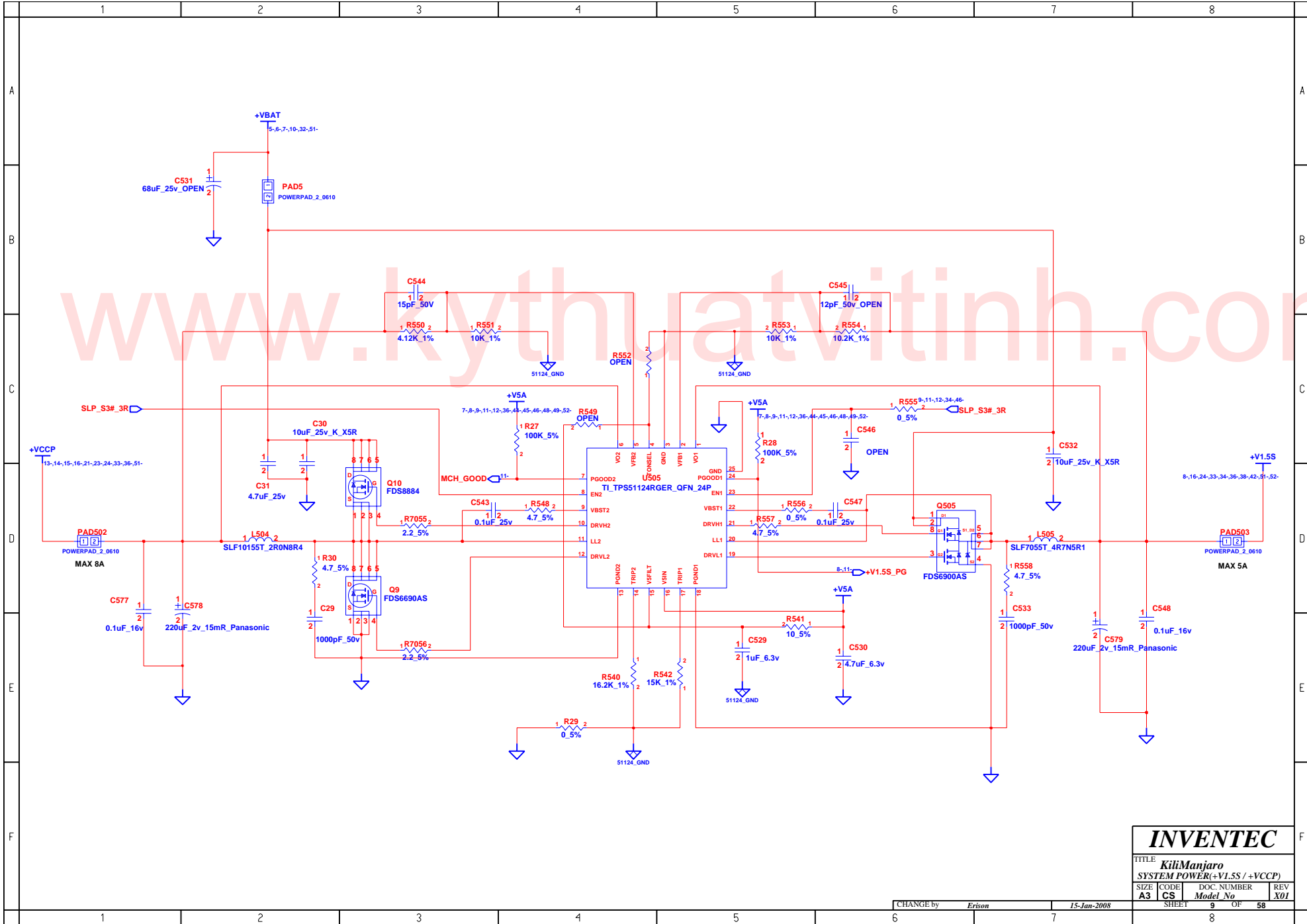

INVENTEC			
TITLE KiliManjaro			
SYSTEM POWER(+V1.5S / +VCCP)			
SIZE A3	CODE CS	DOC. NUMBER Model No	REV X01
CHANGE by Erison		15-Jan-2008	
SHEET 9		OF 58	

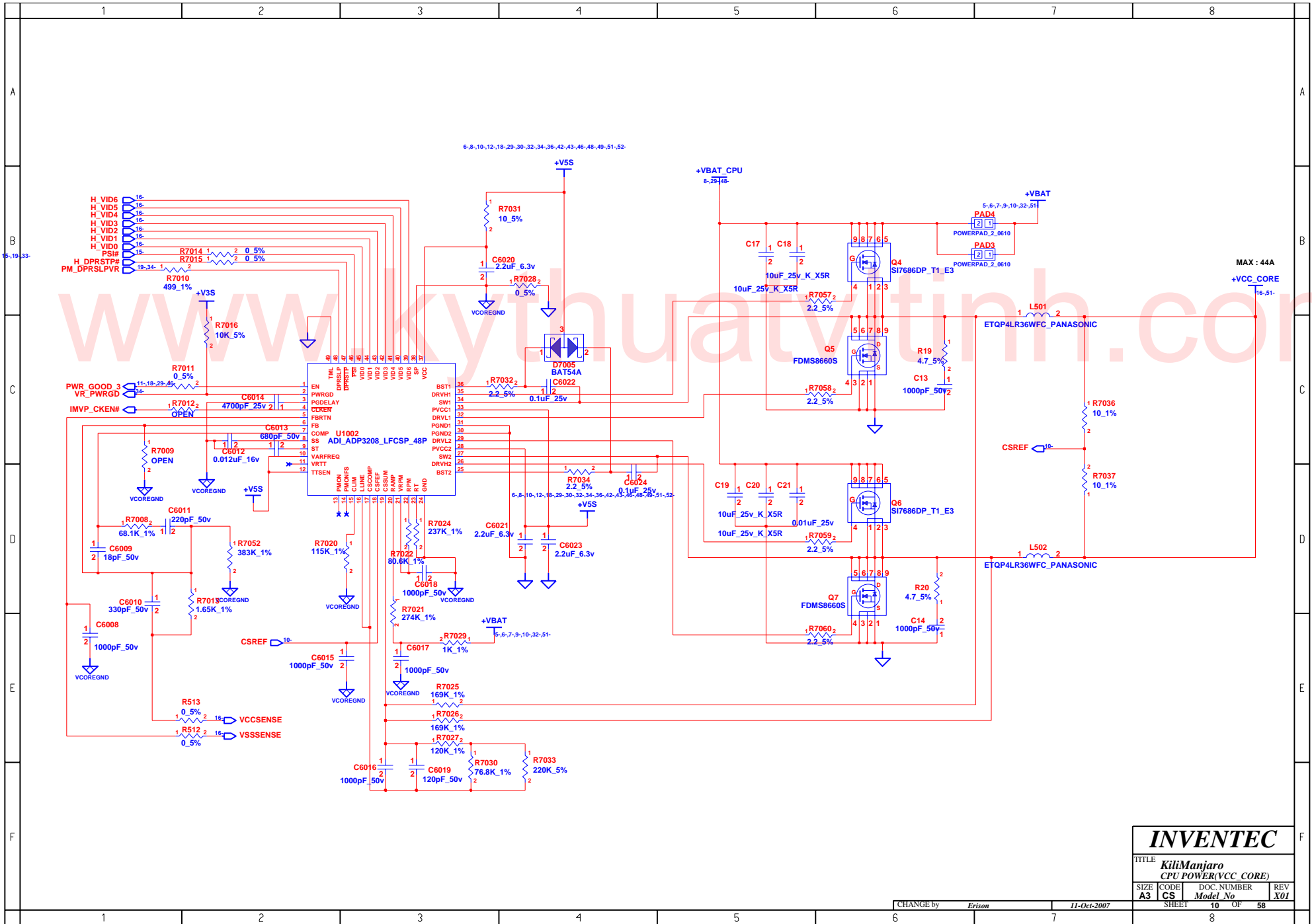

INVENTEC			
TITLE KiliManjaro CPU POWER(VCC_CORE)			
SIZE A3	CODE CS	DOC. NUMBER Model No	REV X01
CHANGE by Erison		11-Oct-2007	
SHEET 10		OF 58	

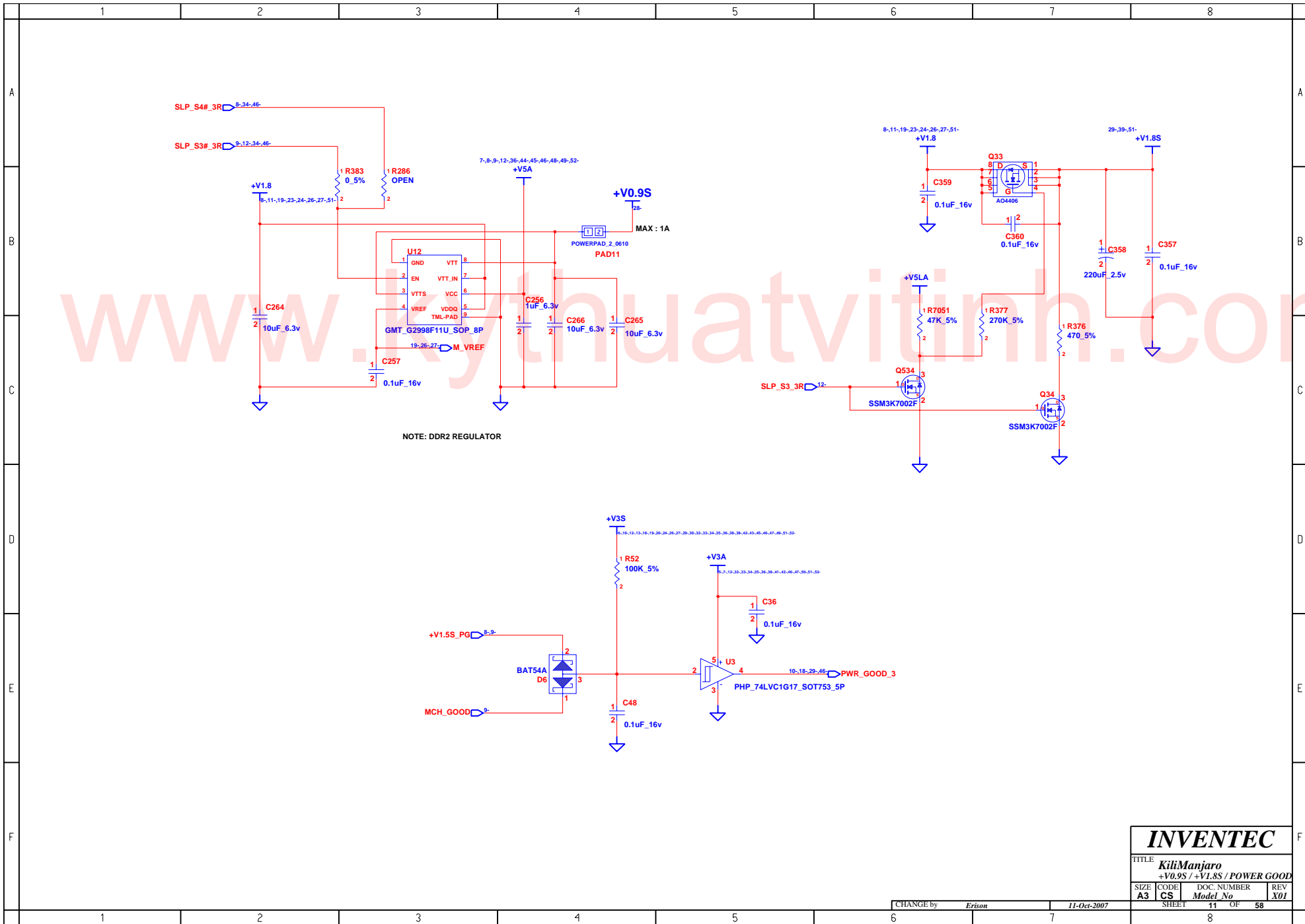

INVENTEC			
TITLE KiliManjaro			
+V0.9S / +V1.8S / POWER GOOD			
SIZE A3	CODE CS	DOC. NUMBER <i>Model No</i>	REV X01
CHANGE by <i>Erison</i>		11-Oct-2007	
SHEET 11		OF 58	

www.kythatvithinh.com

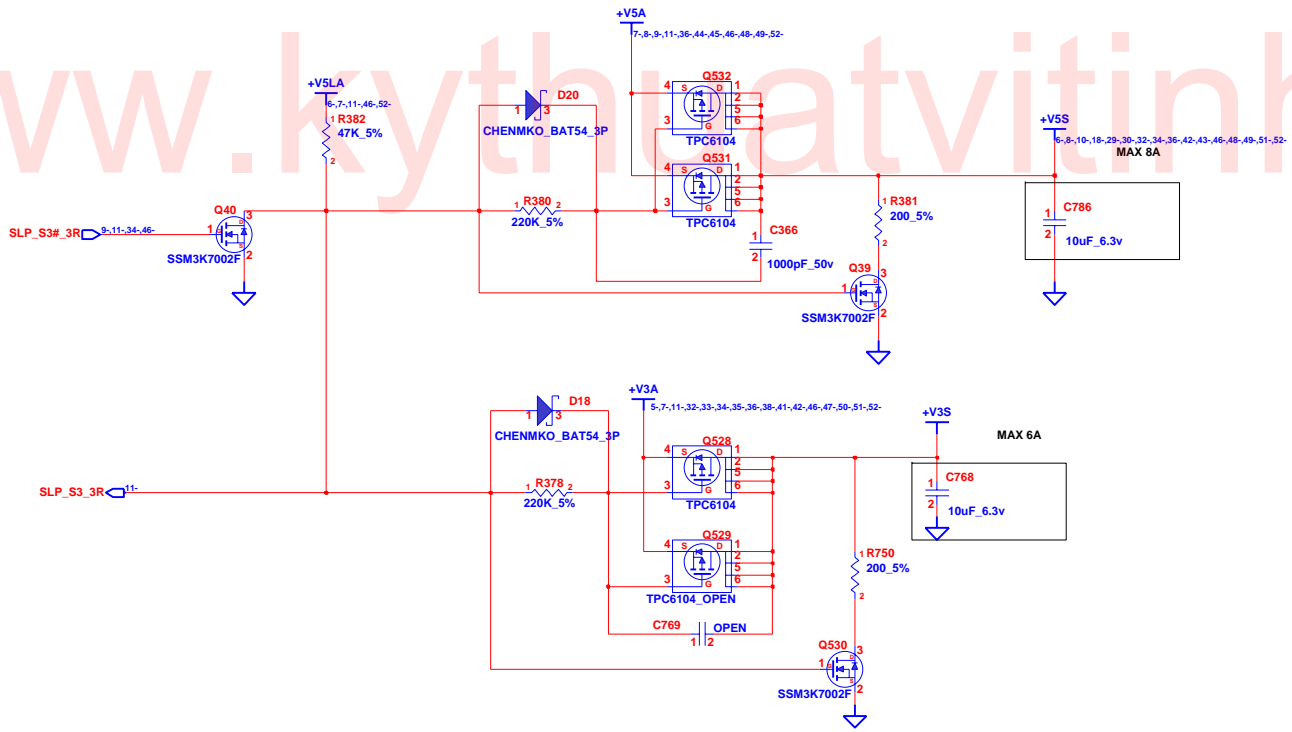

INVENTEC

TITLE			
KiliManjaro			
POWER(+V3S / +V5S)			
SIZE	CODE	DOC. NUMBER	REV
A3	CS	Model No	X01
CHANGE by		11-Oct-2007	
Erison		SHEET 12 OF 58	

CHANGE by Erison 11-Oct-2007

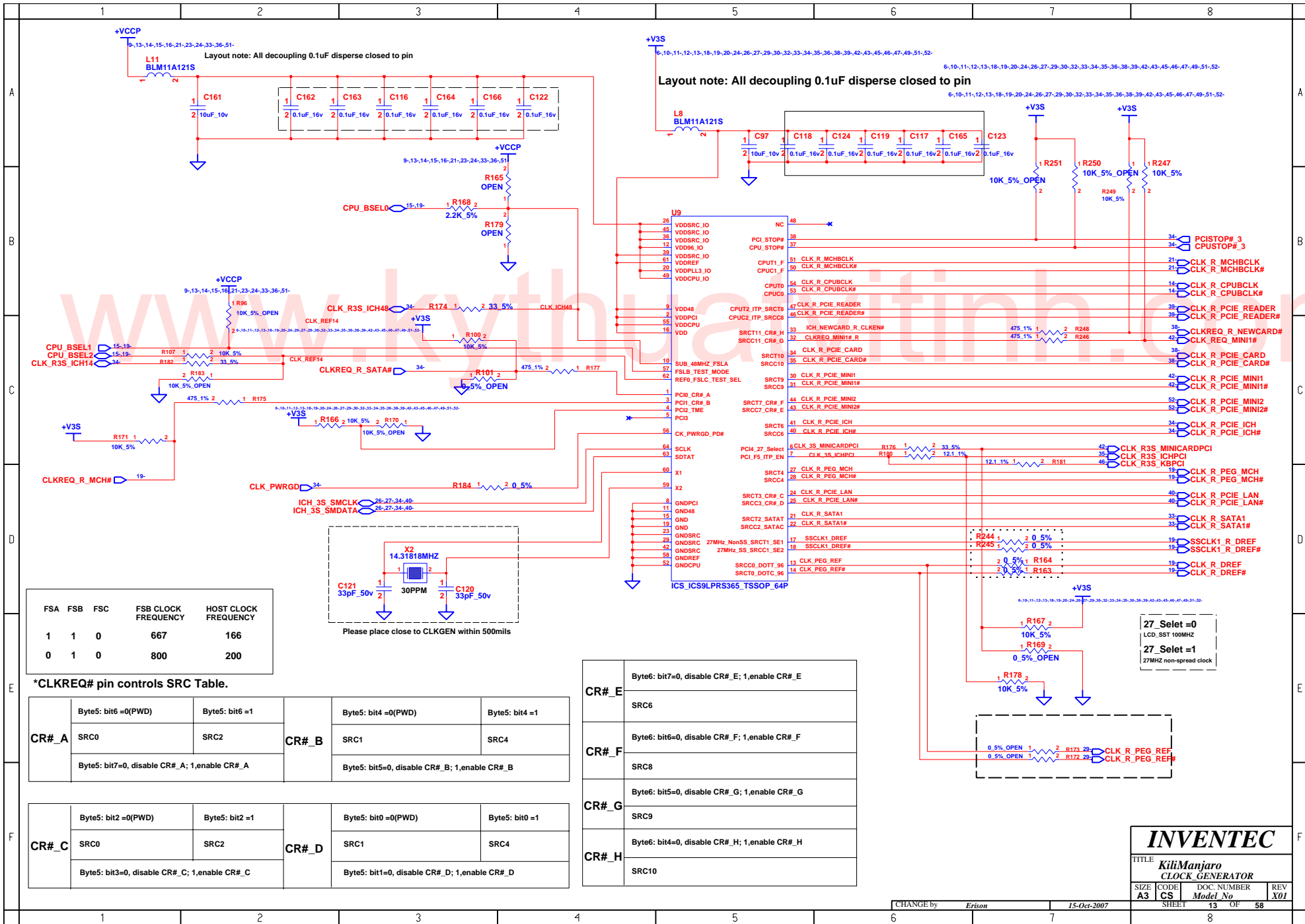

Layout note: All decoupling 0.1uF disperse closed to pin

Layout note: All decoupling 0.1uF disperse closed to pin

6,10,11,12,13,18,19,20,24,26,27,29,30,32,33,34,35,36,38,39,42,43,45,46,47,49,51,52

6,10,11,12,13,18,19,20,24,26,27,29,30,32,33,34,35,36,38,39,42,43,45,46,47,49,51,52

FSA	FSB	FSC	FSB CLOCK FREQUENCY	HOST CLOCK FREQUENCY
1	1	0	667	166
0	1	0	800	200

*CLKREQ# pin controls SRC Table.

CR#_A	Byte5: bit6 =0(PWD)		Byte5: bit6 =1		CR#_B	Byte5: bit4 =0(PWD)		Byte5: bit4 =1	
	SRC0	SRC2	SRC1	SRC4					
Byte5: bit7=0, disable CR#_A; 1,enable CR#_A						Byte5: bit5=0, disable CR#_B; 1,enable CR#_B			

CR#_C	Byte5: bit2 =0(PWD)		Byte5: bit2 =1		CR#_D	Byte5: bit0 =0(PWD)		Byte5: bit0 =1	
	SRC0	SRC2	SRC1	SRC4					
Byte5: bit3=0, disable CR#_C; 1,enable CR#_C						Byte5: bit1=0, disable CR#_D; 1,enable CR#_D			

CR#_E	Byte6: bit7=0, disable CR#_E; 1,enable CR#_E
SRC6	
CR#_F	Byte6: bit6=0, disable CR#_F; 1,enable CR#_F
SRC8	
CR#_G	Byte6: bit5=0, disable CR#_G; 1,enable CR#_G
SRC9	
CR#_H	Byte6: bit4=0, disable CR#_H; 1,enable CR#_H
SRC10	

27_Selet =0
LCD_SST 100MHZ

27_Selet =1
27MHZ non-spread clock

INVENTEC

TITLE
KiliManjaro
CLOCK GENERATOR

SIZE	CODE	DOC. NUMBER	REV
A3	CS	Model No	X01

CHANGE by Erison 15-Oct-2007

SHEET 13 OF 58

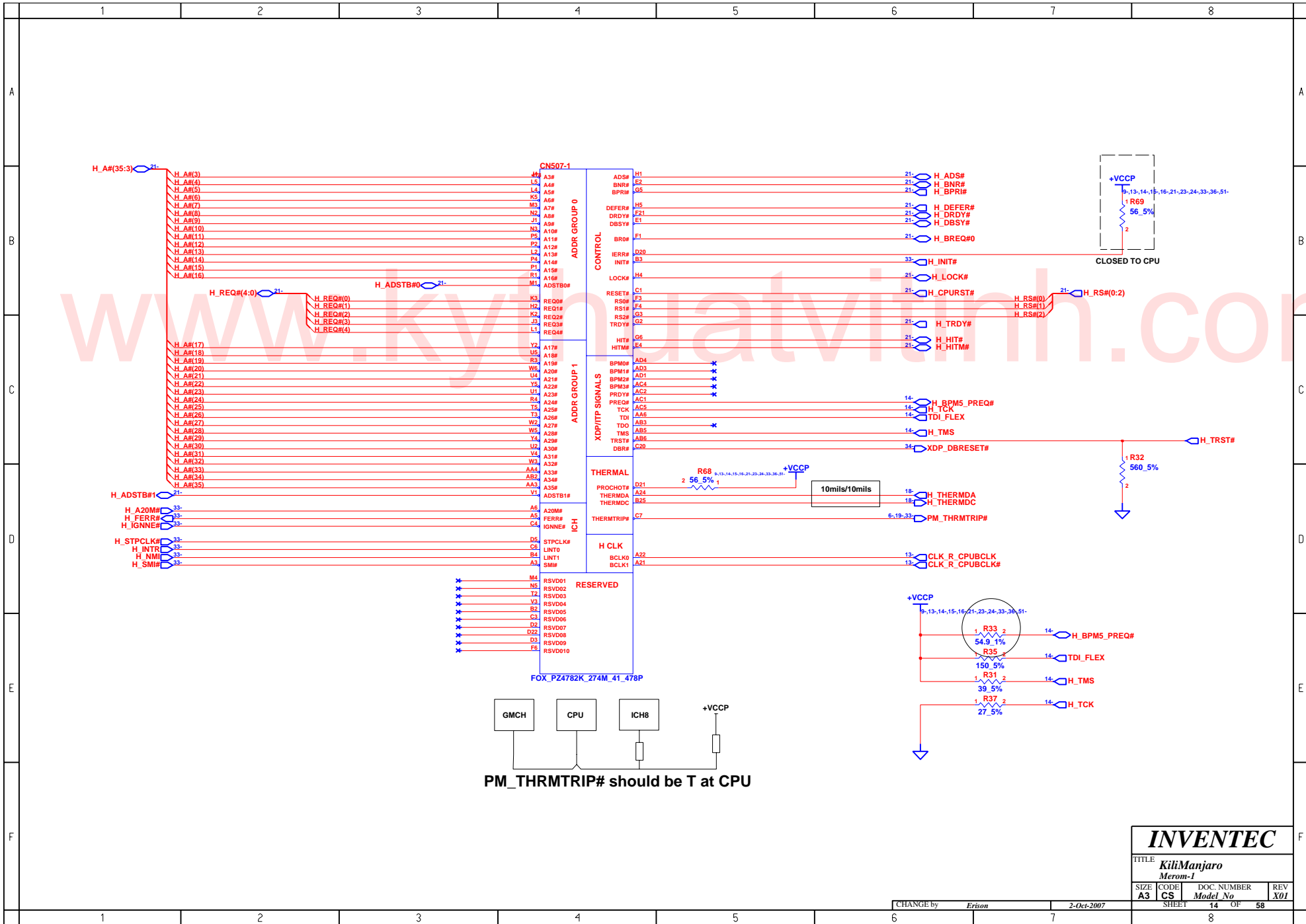

INVENTEC			
TITLE <i>KiliManjaro</i> <i>Merom-1</i>			
SIZE A3	CODE CS	DOC. NUMBER <i>Model No</i>	REV X01
CHANGE by <i>Erison</i>		2-Oct-2007	
SHEET 14		OF 58	

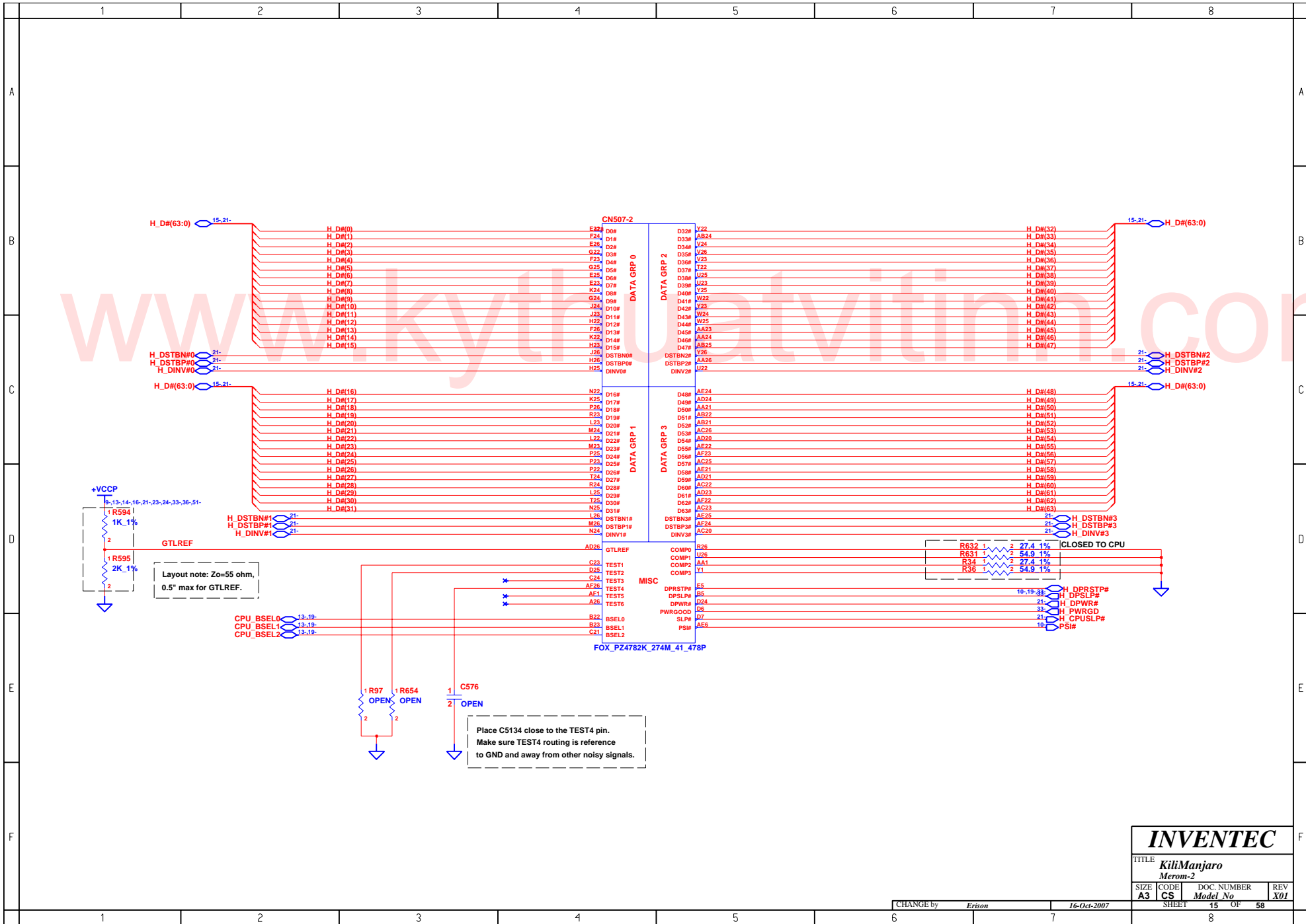

INVENTEC			
TITLE KiliManjaro			
Merom-2			
SIZE A3	CODE CS	DOC. NUMBER Model No	REV X01
CHANGE by <i>Erison</i>		16-Oct-2007	
SHEET 15		OF 58	

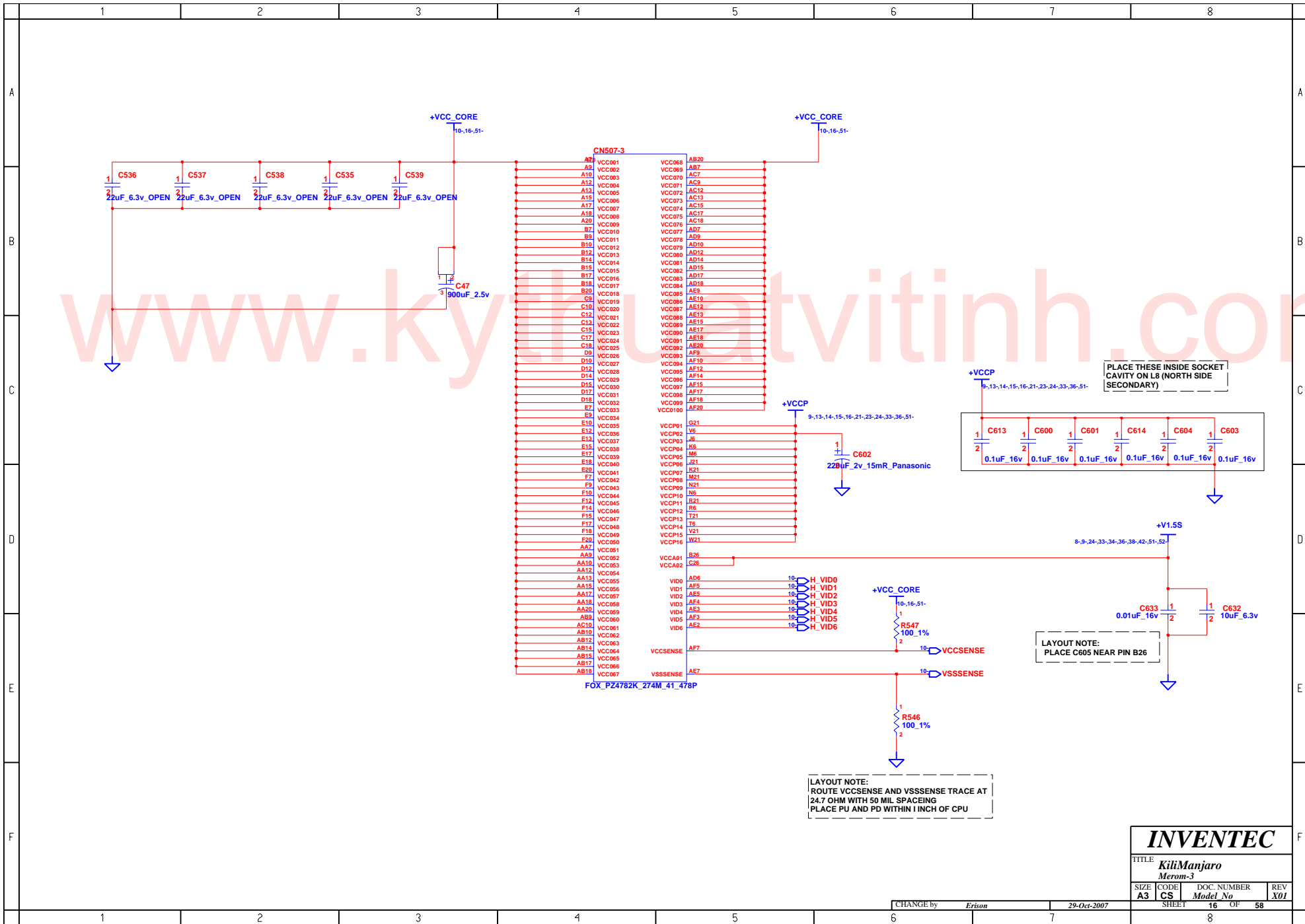

INVENTEC

TITLE			
KiliManjaro			
Merom-3			
SIZE	CODE	DOC. NUMBER	REV
A3	CS	Model No	X01
SHEET 16 OF 58			

CHANGE by *Erison* 29-Oct-2007

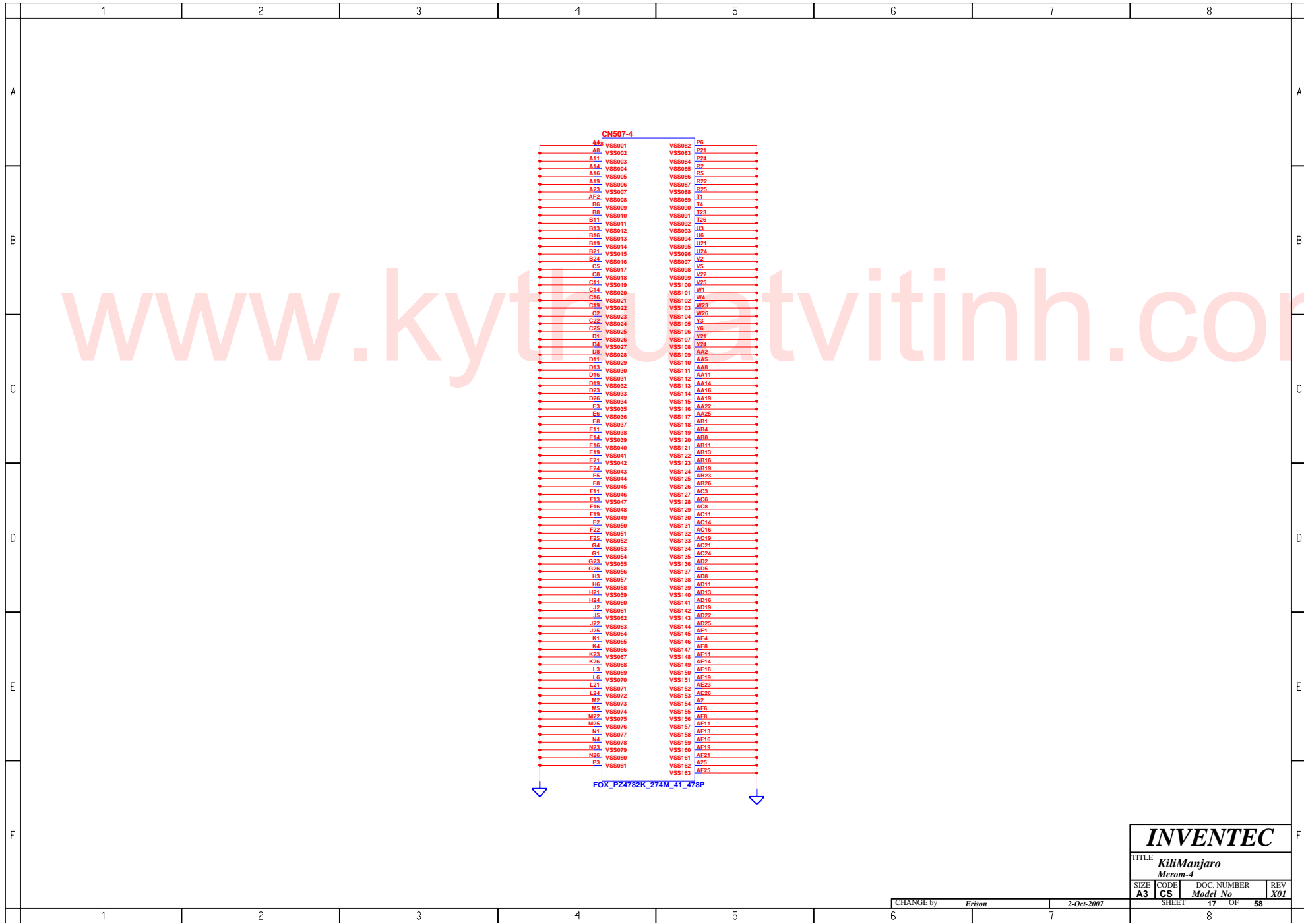

INVENTEC			
TITLE <i>KiliManjaro</i> <i>Merom-4</i>			
SIZE A3	CODE CS	DOC. NUMBER <i>Model No</i>	REV X01
CHANGE by <i>Erison</i>		2-Oct-2007	
SHEET 17		OF 58	

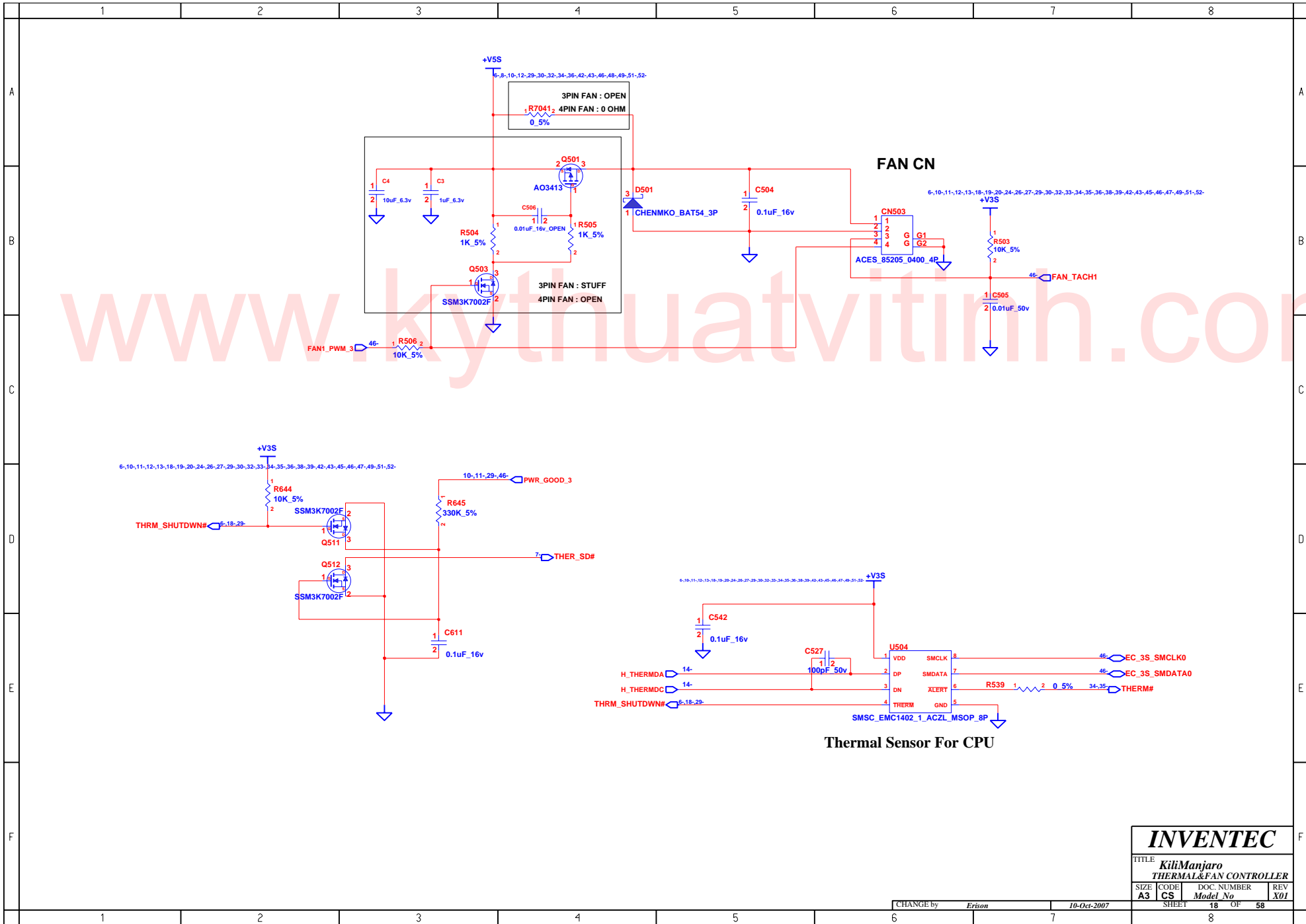

INVENTEC			
TITLE KiliManjaro			
THERMAL&FAN CONTROLLER			
SIZE A3	CODE CS	DOC. NUMBER Model No	REV X01
CHANGE by <i>Erison</i>		10-Oct-2007	SHEET 18 OF 58

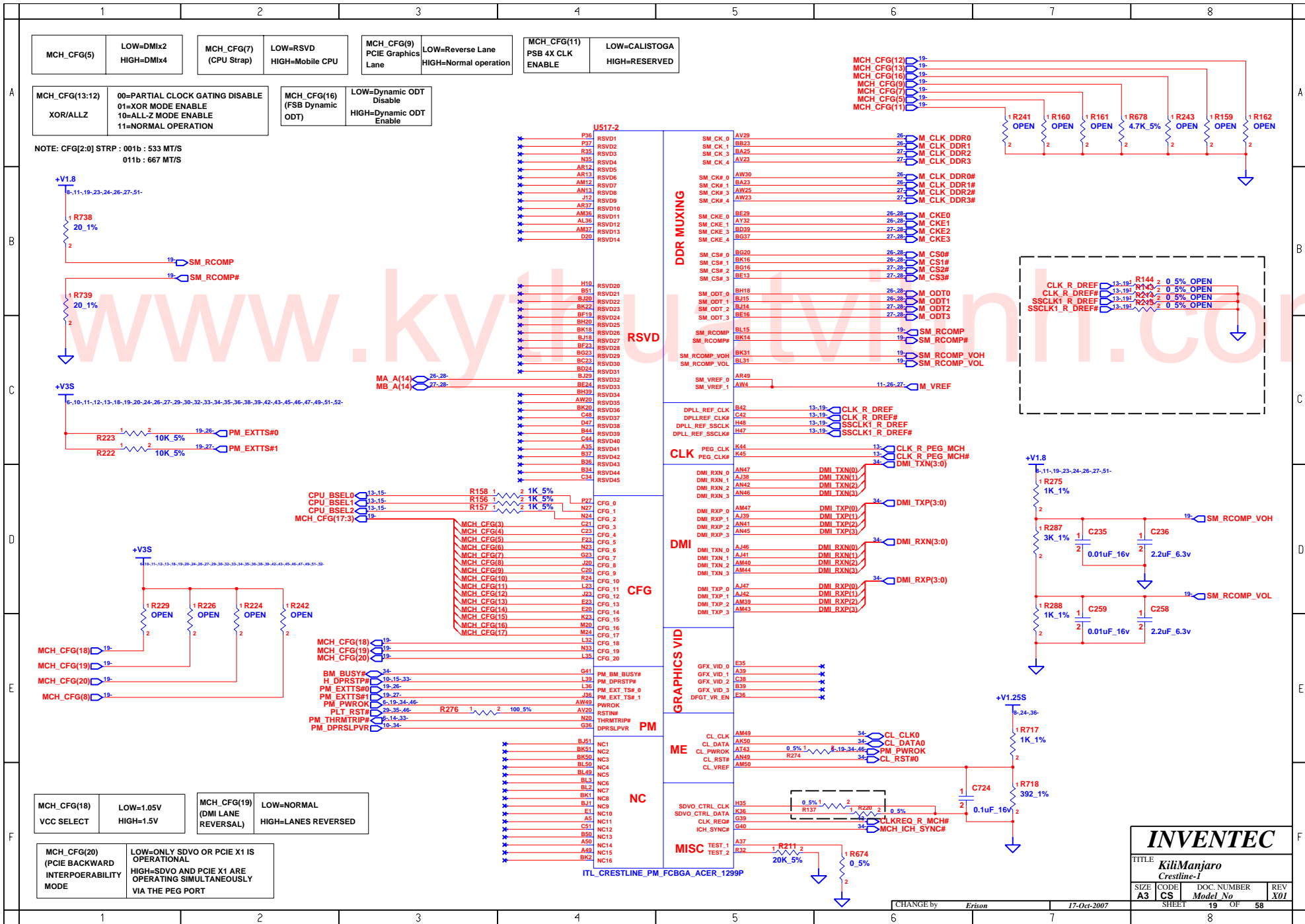

INVENTEC

TITLE: KiliManjaro Crestline-I

SIZE	CODE	DOC. NUMBER	REV
A3	CS	Model No	X01

SHEET 19 OF 58

CHANGE by Erison 17-Oct-2007

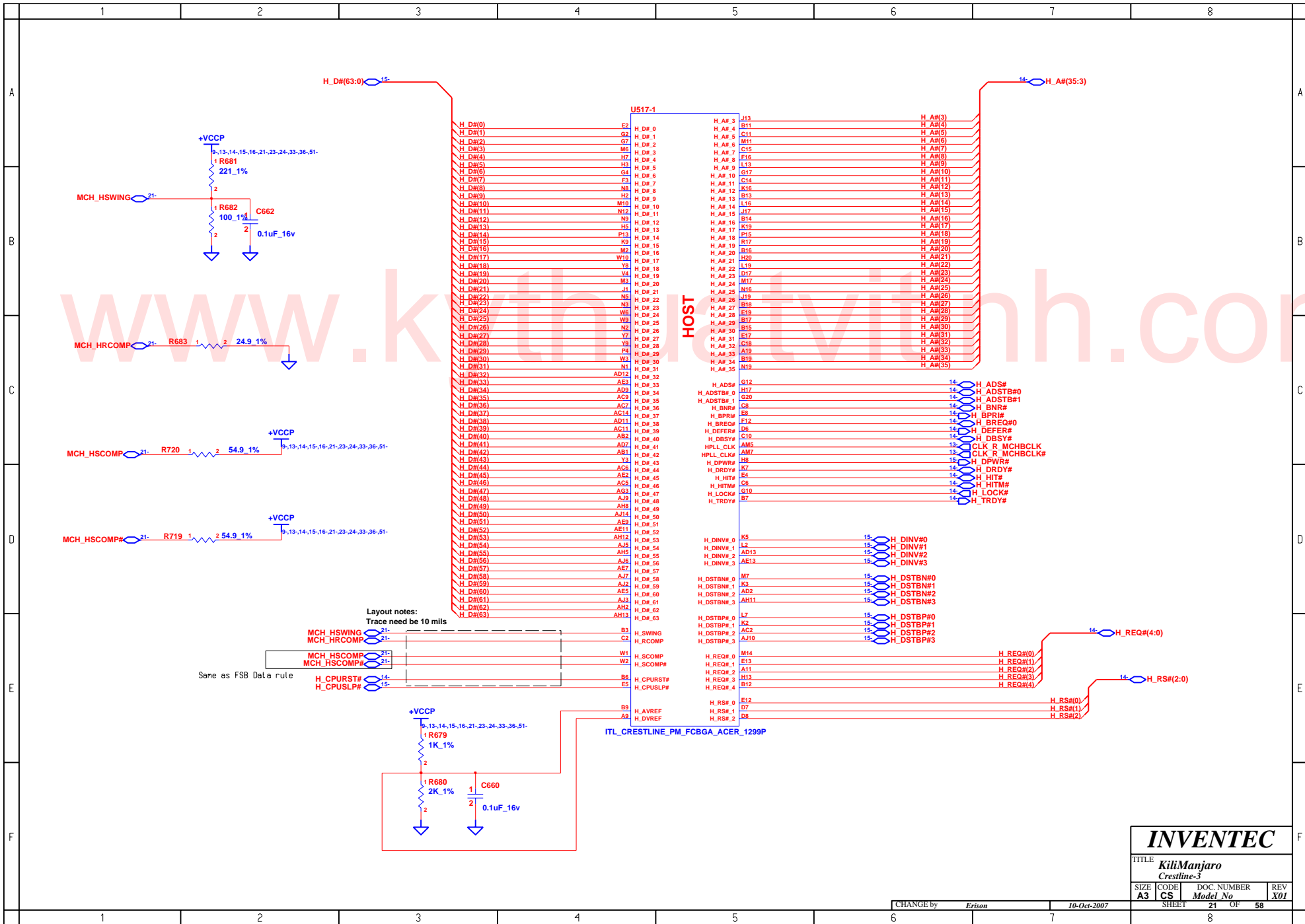

INVENTEC			
TITLE KiliManjaro Crestline-3			
SIZE A3	CODE CS	DOC. NUMBER Model No	REV X01
CHANGE by Erison		10-Oct-2007	
SHEET 21		OF 58	

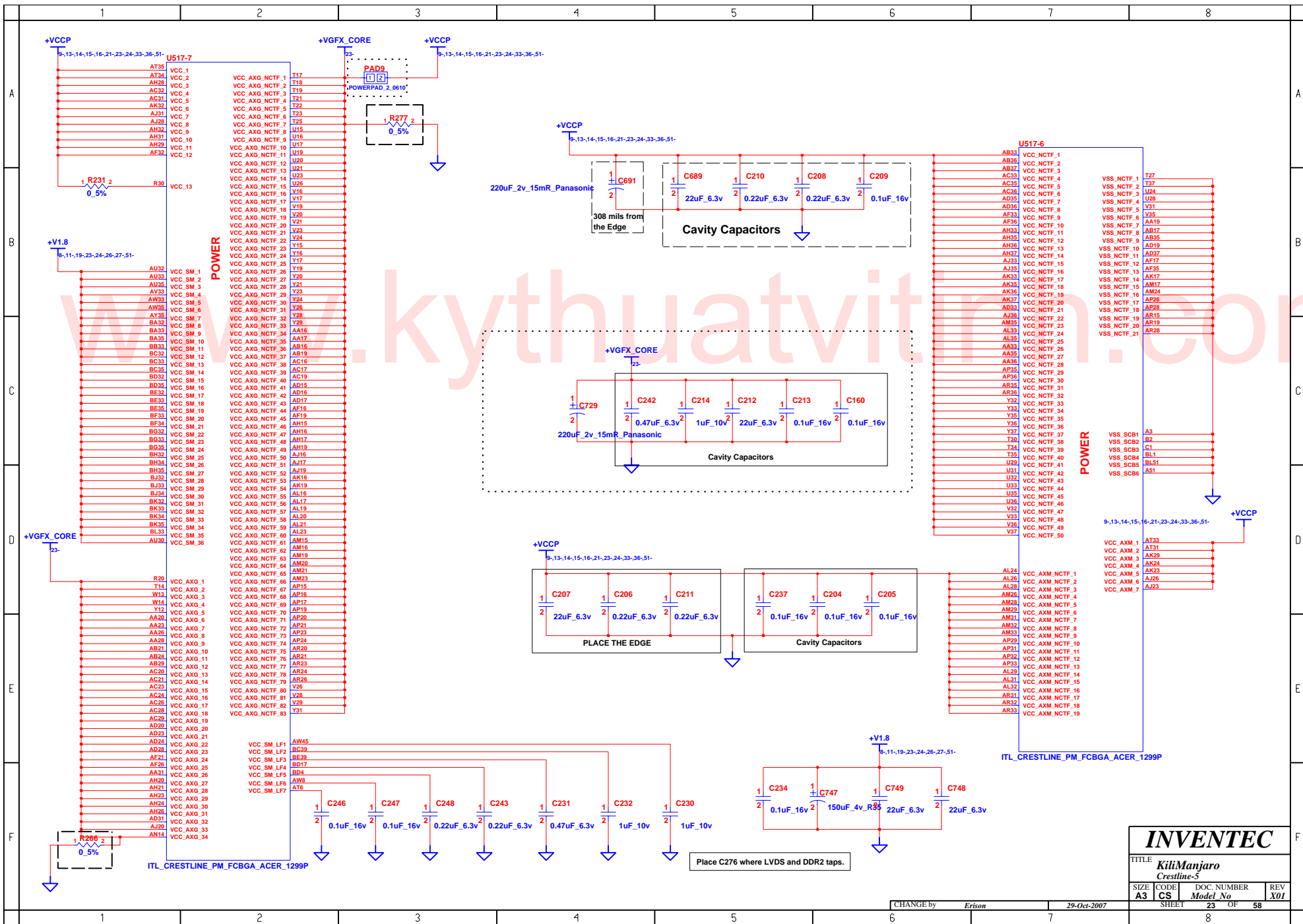

INVENTEC			
TITLE <i>KiliManjaro Crestline-5</i>			
SIZE A3	CODE CS	DOC. NUMBER <i>Model No</i>	REV X01
CHANGE by <i>Erison</i>		29-Oct-2007	
SHEET 23		OF 58	

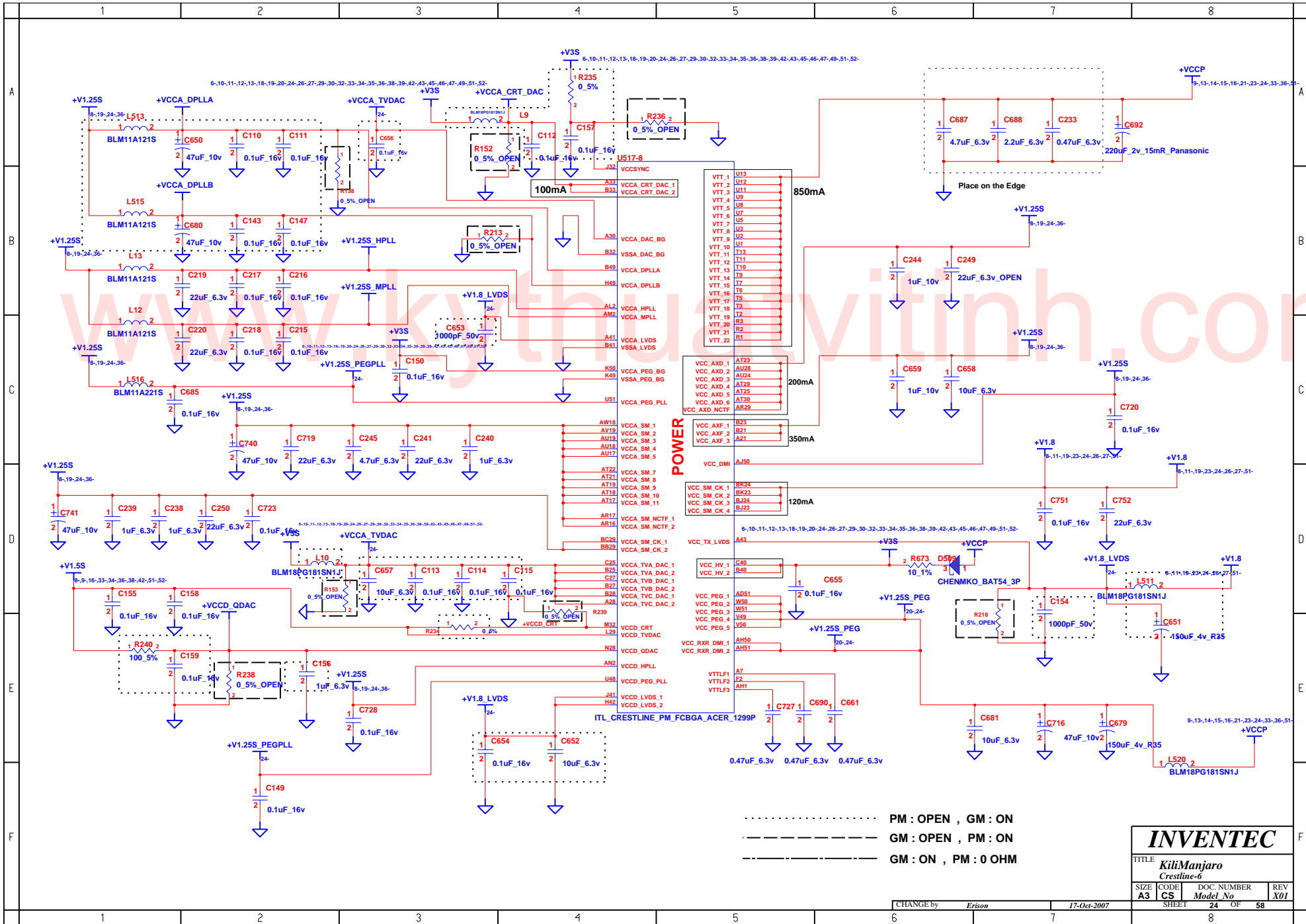

..... PM : OPEN , GM : ON
 - - - - - GM : OPEN , PM : ON
 _____ GM : ON , PM : 0 OHM

INVENTEC			
TITLE KiliManjaro Crestline-6			
SIZE A3	CODE CS	DOC. NUMBER Model No	REV X01
CHANGE by Erison		17-Oct-2007	
SHEET 24		OF 58	

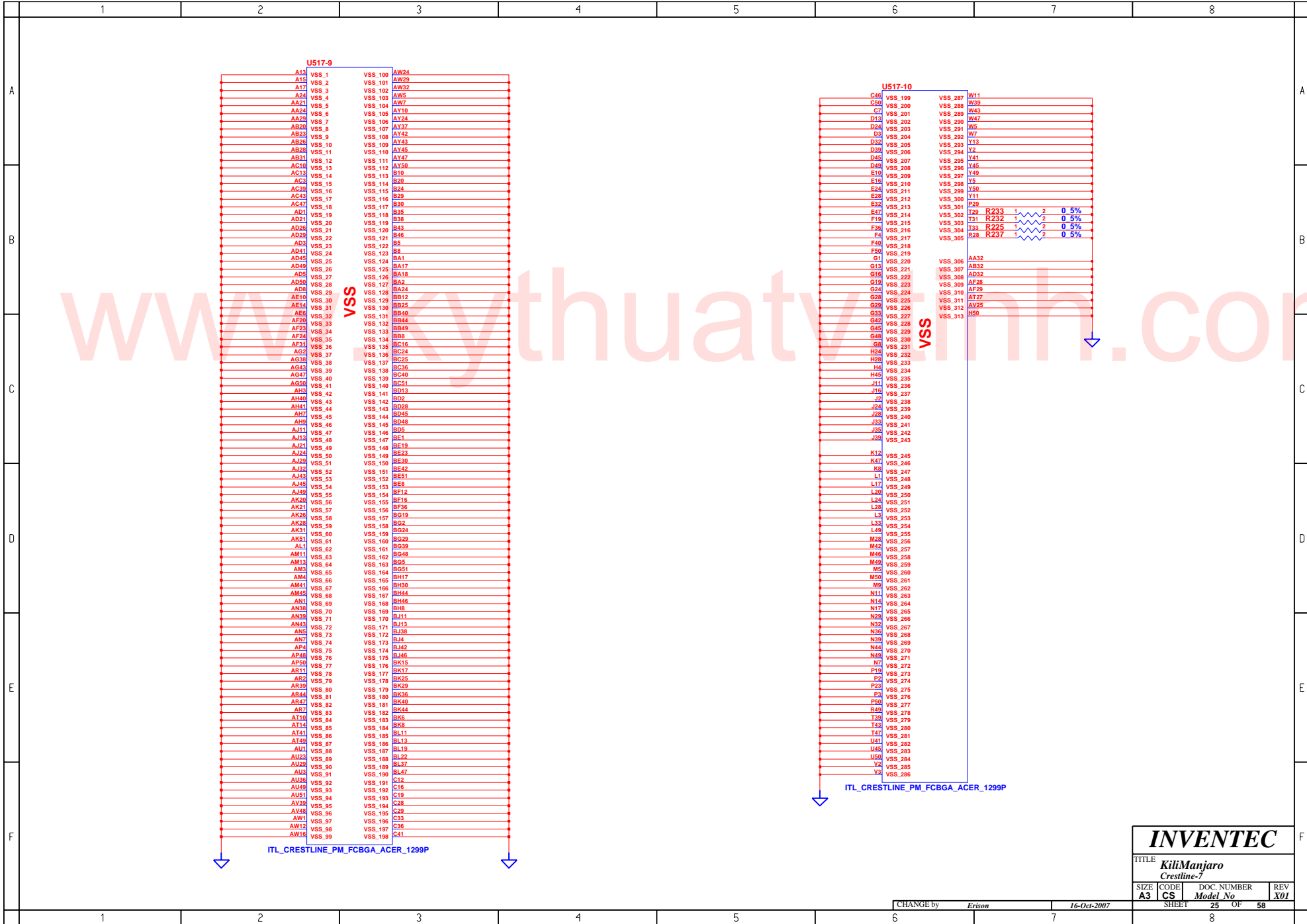

INVENTEC			
TITLE KiliManjaro Crestline-7			
SIZE A3	CODE CS	DOC. NUMBER Model No	REV X01
CHANGE by Erison		16-Oct-2007	SHEET 25 OF 58

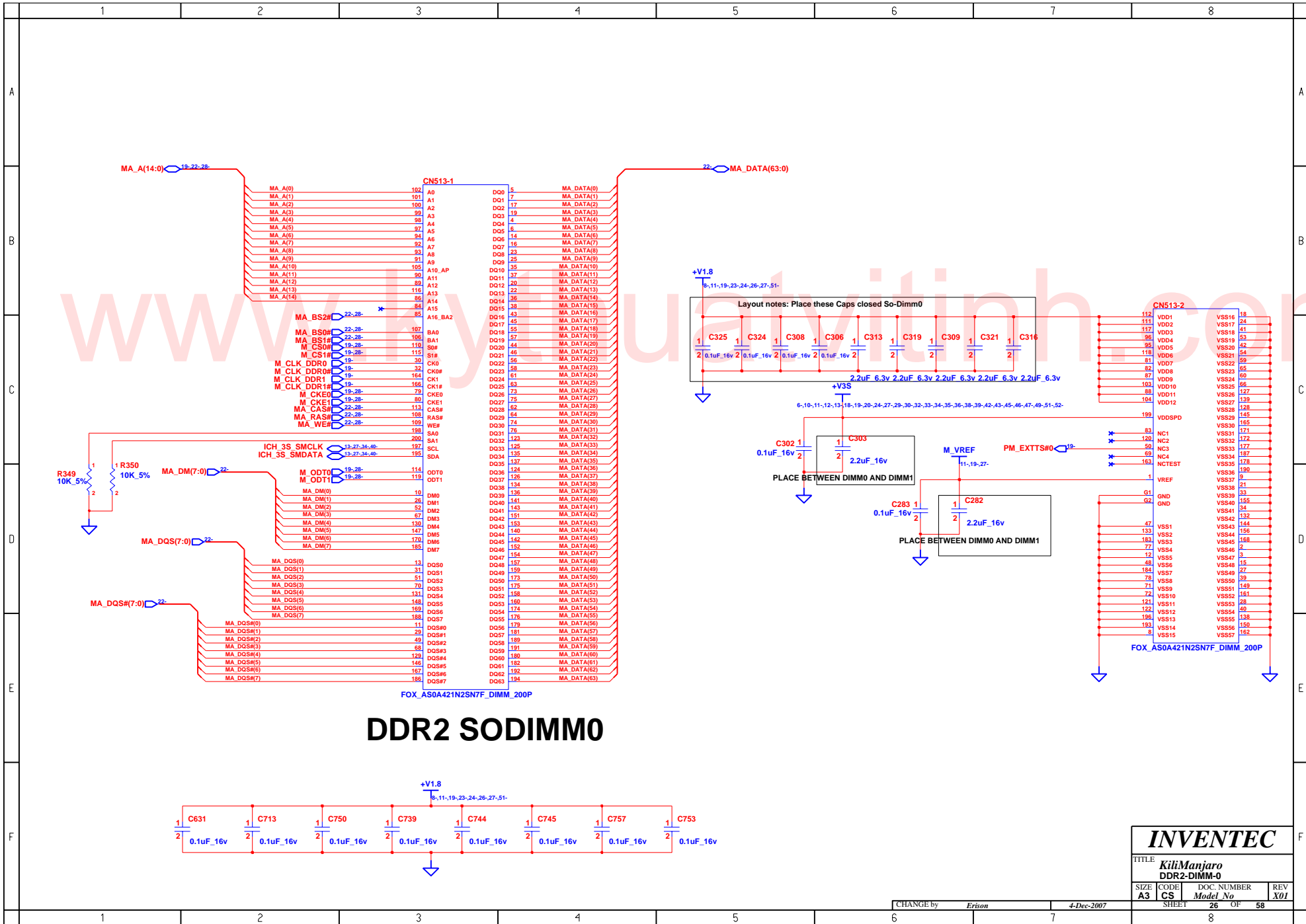

INVENTEC			
TITLE KiliManjaro DDR2-DIMM-0			
SIZE A3	CODE CS	DOC. NUMBER Model No	REV X01
CHANGE by Erison		4-Dec-2007	
SHEET 26		OF 58	
8			

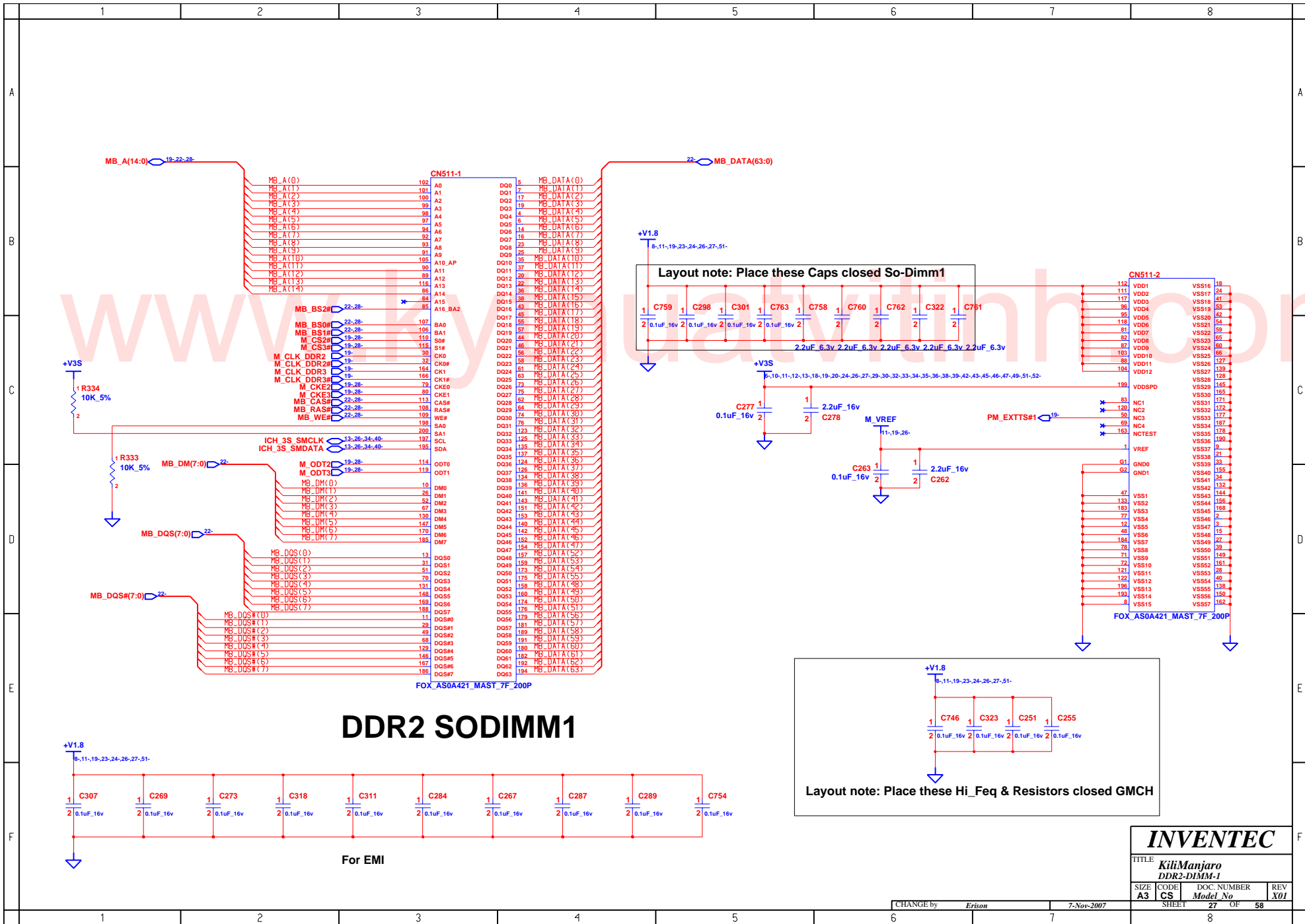

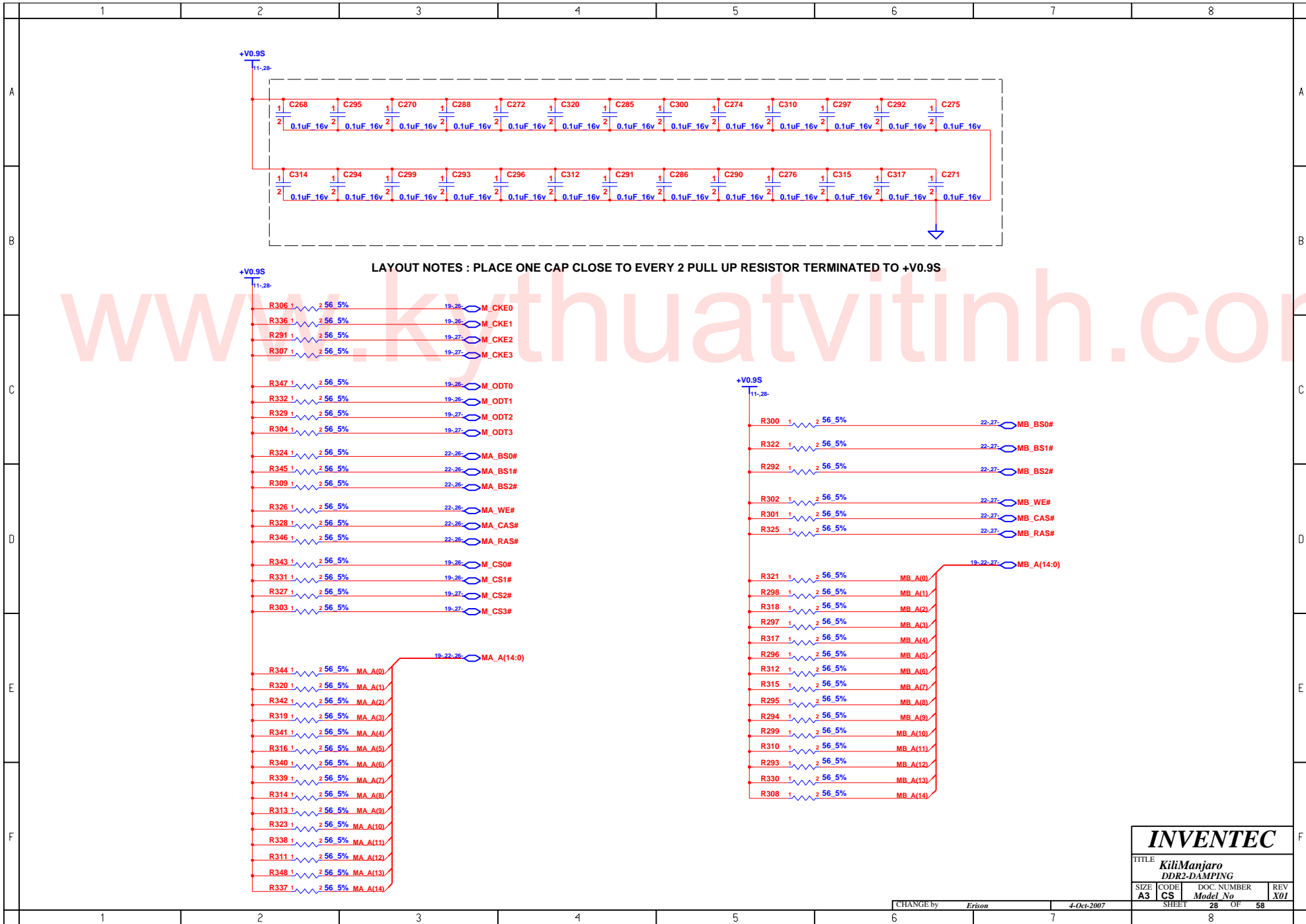

LAYOUT NOTES : PLACE ONE CAP CLOSE TO EVERY 2 PULL UP RESISTOR TERMINATED TO +V0.9S

www.kyathuatvithinh.com

INVENTEC

TITLE
KiliManjaro
 DDR2-DAMPING

SIZE A3	CODE CS	DOC. NUMBER <i>Model No</i>	REV X01
-------------------	-------------------	--------------------------------	-------------------

CHANGE by *Erison* 4-Oct-2007

SHEET 28 OF 58

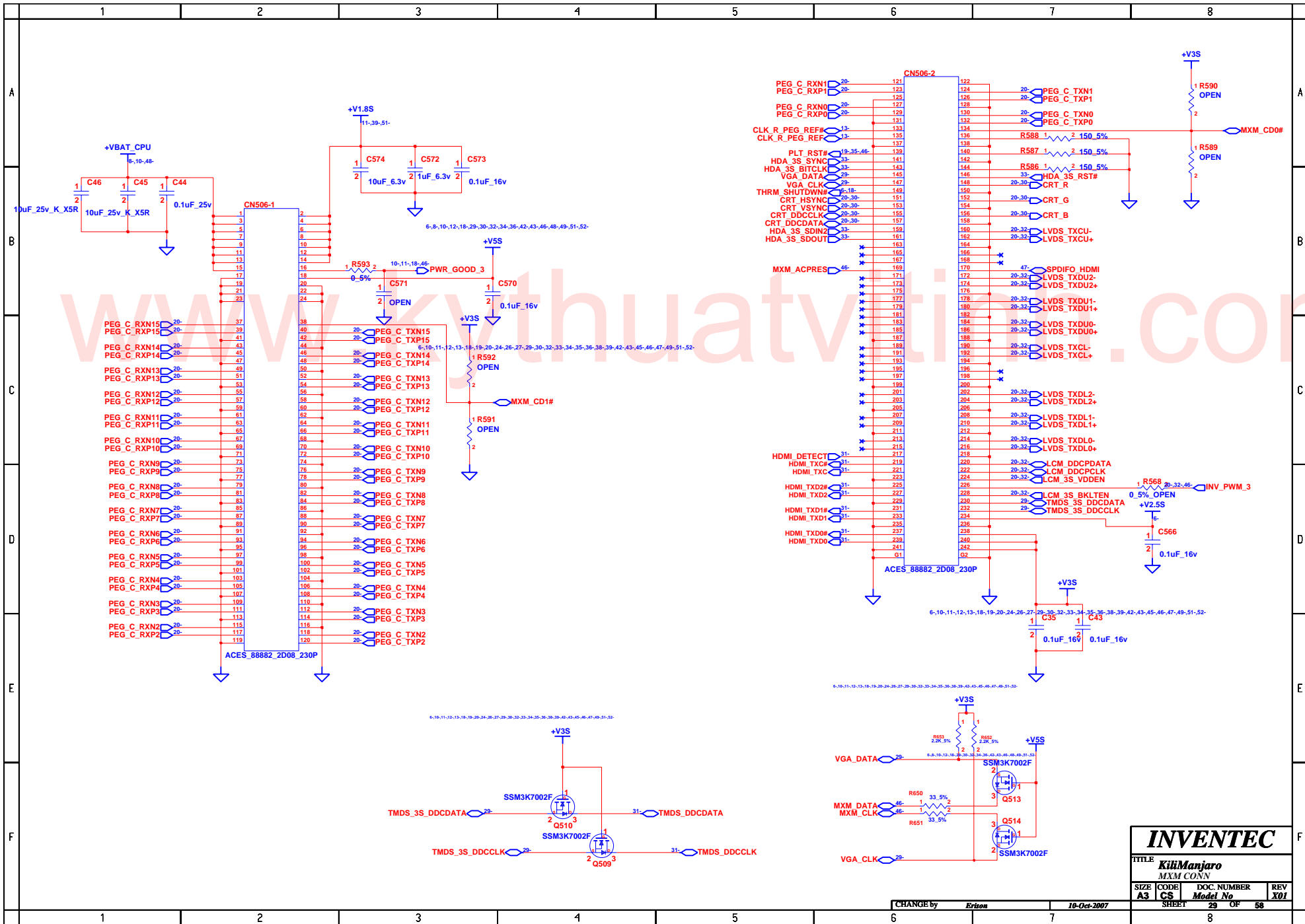

INVENTEC			
TITLE KiliManjaro MXM CONN			
SIZE A3	CODE CS	DOC. NUMBER Model No	REV X01
SHEET 29		OF 58	

CHANGE by *Erison* 10-Oct-2007

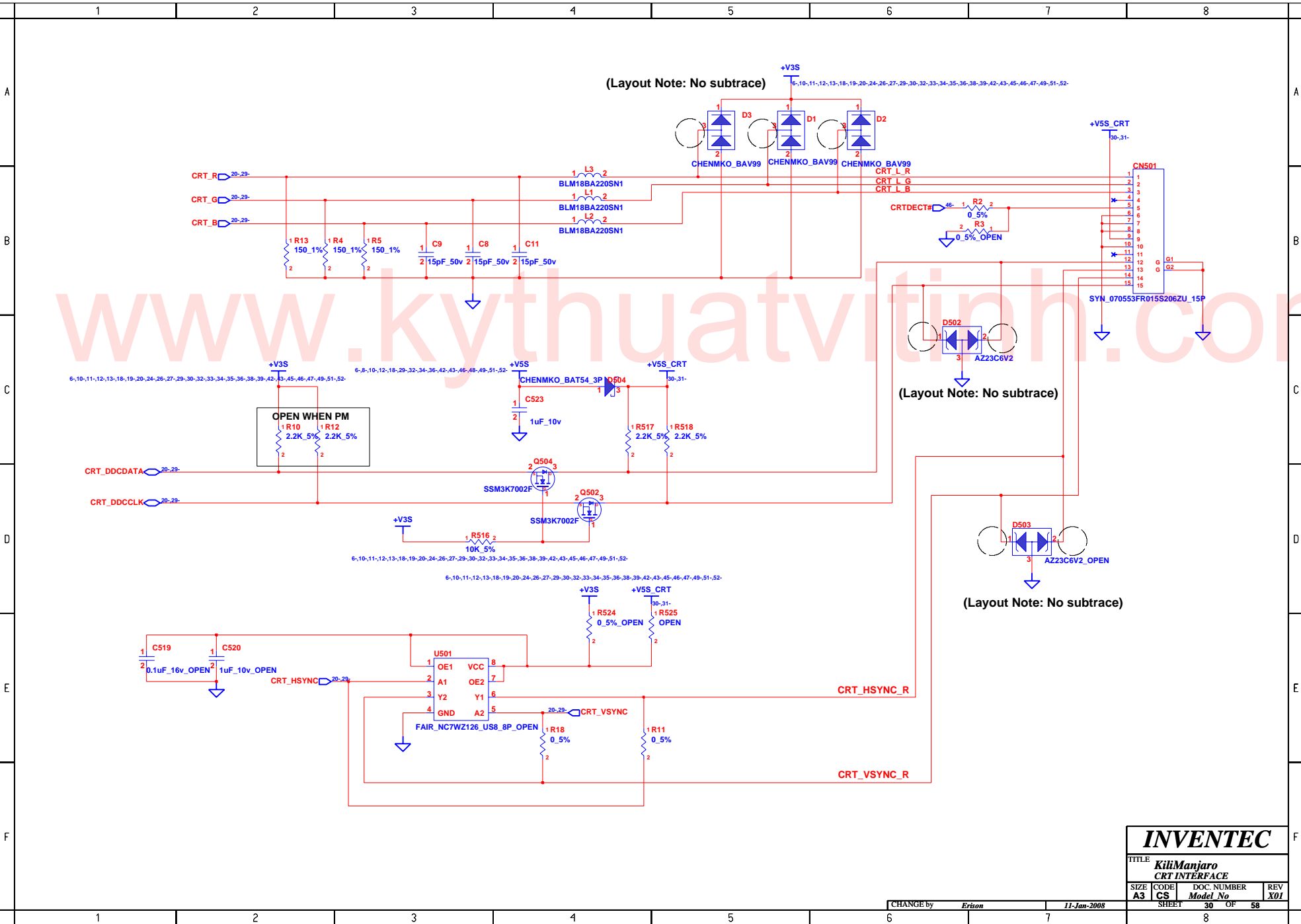

INVENTEC			
TITLE KiliManjaro CRT INTERFACE			
SIZE A3	CODE CS	DOC NUMBER Model No	REV X01
CHANGE by <i>Erison</i>		11-Jan-2008	
SHEET		30 OF 58	

www.kythuatchitinh.com

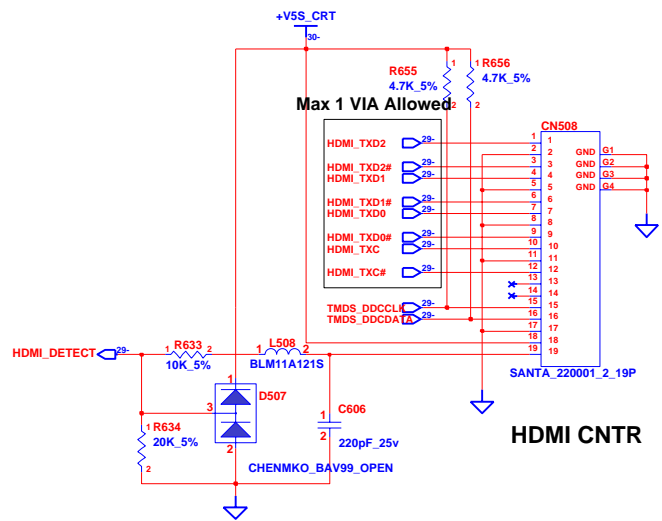

INVENTEC			
TITLE <i>KiliManjaro</i>			
HDMI			
SIZE	CODE	DOC. NUMBER	REV
A3	CS	Model No	X01
CHANGE by <i>Erison</i>		5-Dec-2007	
SHEET		31	OF 58
		8	

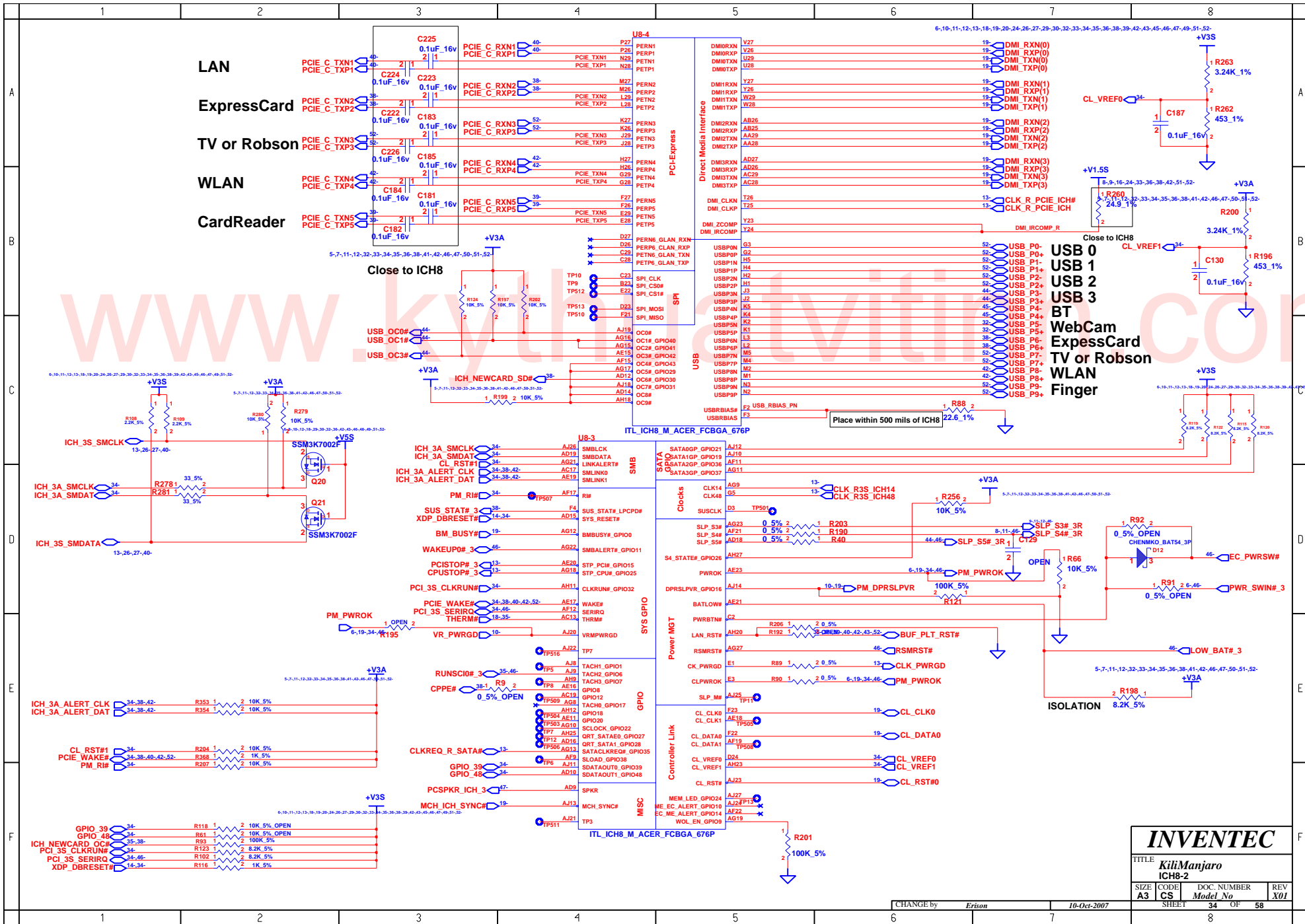

INVENTEC			
TITLE KiliManjaro ICH8-2			
SIZE A3	CODE CS	DOC. NUMBER <i>Model No</i>	REV X01
CHANGE by <i>Erison</i>		10-Oct-2007	
SHEET 34		OF 58	

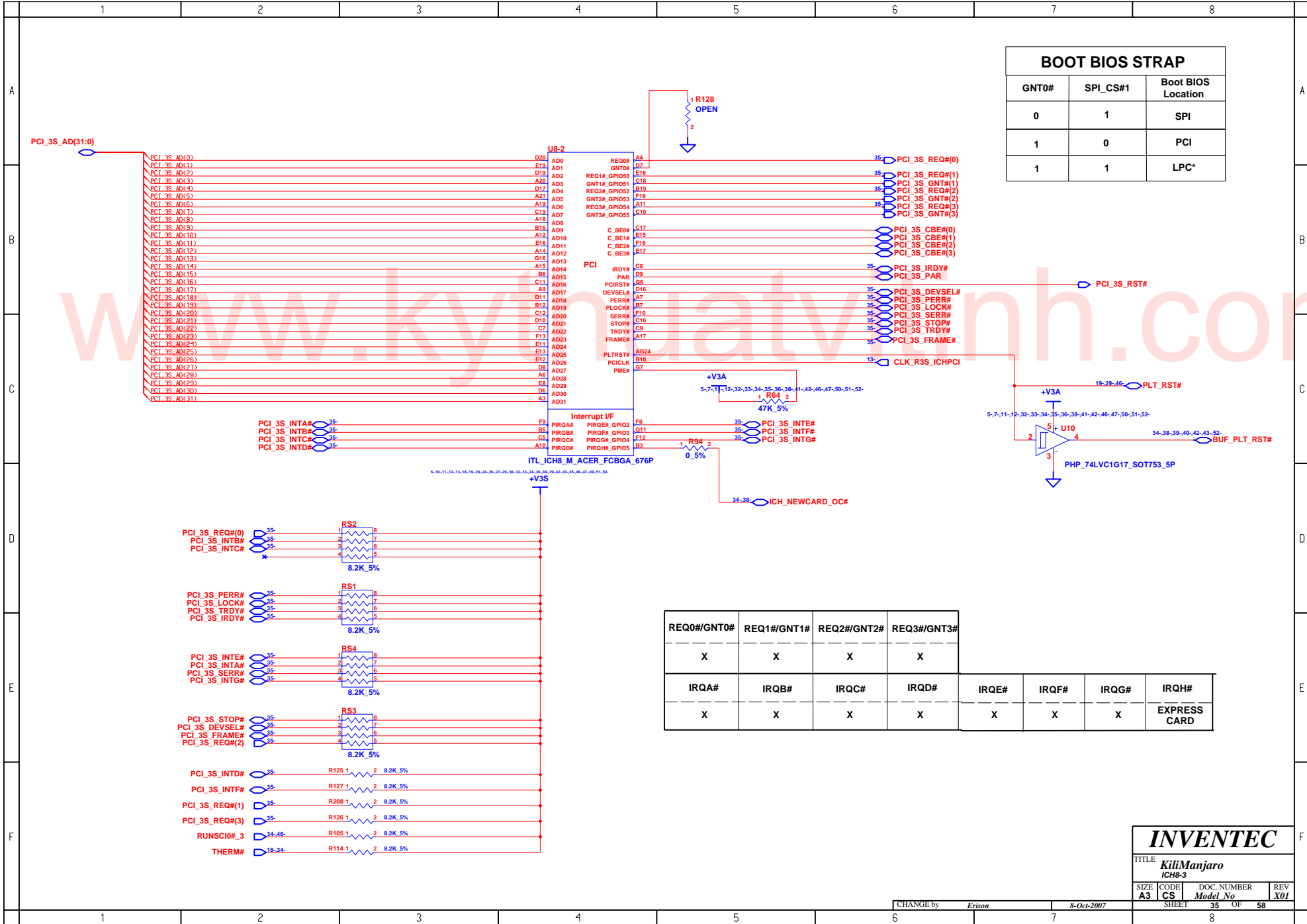

BOOT BIOS STRAP		
GNT0#	SPI_CS#1	Boot BIOS Location
0	1	SPI
1	0	PCI
1	1	LPC*

REQ0#/GNT0#	REQ1#/GNT1#	REQ2#/GNT2#	REQ3#/GNT3#	IRQA#	IRQB#	IRQC#	IRQD#	IRQE#	IRQF#	IRQG#	IRQH#
X	X	X	X	X	X	X	X	X	X	X	EXPRESS CARD

INVENTEC			
TITLE KiliManjaro ICH8-3			
SIZE A3	CODE CS	DOC. NUMBER Model No	REV X01
CHANGE by Erison		8-Oct-2007	
SHEET 35		OF 58	

	1	2	3	4	5	6	7	8	
A									
B									
C									
D									
E									
F									

U8-5

A23	VSS001	VSS090	K7
A3	VSS002	VSS100	L1
AA2	VSS003	VSS100	L13
AA7	VSS004	VSS100	L15
A25	VSS005	VSS100	L26
AB1	VSS006	VSS104	L27
AB24	VSS007	VSS106	L4
AC11	VSS008	VSS106	L5
AC14	VSS009	VSS107	M12
AC24	VSS010	VSS108	M13
AC26	VSS011	VSS108	M14
AC27	VSS012	VSS110	M15
AD17	VSS013	VSS111	M16
AD20	VSS014	VSS112	M17
AD28	VSS015	VSS113	M23
AD29	VSS016	VSS114	M28
AD3	VSS017	VSS115	M29
AD4	VSS018	VSS116	N1
AD6	VSS019	VSS115	N1
AE1	VSS020	VSS118	M11
AE12	VSS021	VSS119	M12
AE2	VSS022	VSS120	M13
AE22	VSS023	VSS121	N14
AD1	VSS024	VSS122	M15
AE29	VSS025	VSS123	M16
AE5	VSS026	VSS124	M17
AE6	VSS027	VSS124	M18
AE9	VSS028	VSS126	N26
AF14	VSS029	VSS127	N27
AF16	VSS030	VSS128	M4
AF18	VSS031	VSS129	N5
AF3	VSS032	VSS130	N6
AF4	VSS033	VSS131	P12
AG5	VSS034	VSS133	P13
AG6	VSS035	VSS133	P14
AH10	VSS036	VSS134	P15
AH13	VSS037	VSS136	P16
AH16	VSS038	VSS136	P17
AH19	VSS039	VSS137	P23
AH2	VSS040	VSS138	P28
AH20	VSS041	VSS139	P29
AH22	VSS042	VSS140	R11
AH24	VSS043	VSS141	R12
AH26	VSS044	VSS142	R13
AH3	VSS045	VSS144	R14
AH4	VSS046	VSS144	R15
AH8	VSS047	VSS146	R16
A49	VSS048	VSS146	R17
B11	VSS049	VSS146	R18
B14	VSS050	VSS146	R28
B17	VSS051	VSS148	R4
B2	VSS052	VSS150	T12
B20	VSS053	VSS151	T13
B22	VSS054	VSS152	T14
B8	VSS055	VSS153	T15
C24	VSS056	VSS154	T16
C25	VSS057	VSS155	T17
C27	VSS058	VSS156	T2
C6	VSS059	VSS157	T12
D12	VSS060	VSS158	U14
D15	VSS061	VSS159	U14
D18	VSS062	VSS160	U15
D2	VSS063	VSS161	U16
D4	VSS064	VSS163	U17
E21	VSS065	VSS163	U23
E24	VSS066	VSS164	U26
E4	VSS067	VSS165	U27
E9	VSS068	VSS166	U3
F15	VSS069	VSS165	U5
E23	VSS070	VSS168	V13
F28	VSS071	VSS169	V15
F29	VSS072	VSS170	V29
F7	VSS073	VSS171	V29
G1	VSS074	VSS172	W2
E2	VSS075	VSS173	W25
G10	VSS076	VSS174	W27
G13	VSS077	VSS174	Y28
G19	VSS078	VSS176	Y29
G23	VSS079	VSS177	Y4
G25	VSS080	VSS178	AB4
G26	VSS081	VSS179	AB23
G27	VSS082	VSS180	AB5
H25	VSS083	VSS181	AB6
H28	VSS084	VSS183	AD5
H29	VSS085	VSS183	U4
H3	VSS086	VSS184	W24
H6	VSS087	VSS_NCTF_01	A1
J1	VSS088	VSS_NCTF_02	A2
J25	VSS089	VSS_NCTF_03	A28
J26	VSS090	VSS_NCTF_04	A29
J27	VSS091	VSS_NCTF_05	AH1
J4	VSS092	VSS_NCTF_06	AH29
J5	VSS093	VSS_NCTF_07	AJ1
K23	VSS094	VSS_NCTF_08	AJ2
K26	VSS095	VSS_NCTF_09	AJ29
K29	VSS096	VSS_NCTF_010	AJ29
K3	VSS097	VSS_NCTF_011	B1
K4	VSS098	VSS_NCTF_012	B29

ITL_ICH8_M_ACER_FCBGA_676P



www.kynuatvitrine.com

INVENTEC

TITLE			
KiliManjaro			
ICH8-5			
SIZE	CODE	DOC. NUMBER	REV
A3	CS	Model No	X01
SHEET		OF	
37		OF	58

CHANGE by *Erison* 4-Oct-2007

	1	2	3	4	5	6	7	8	
--	---	---	---	---	---	---	---	---	--

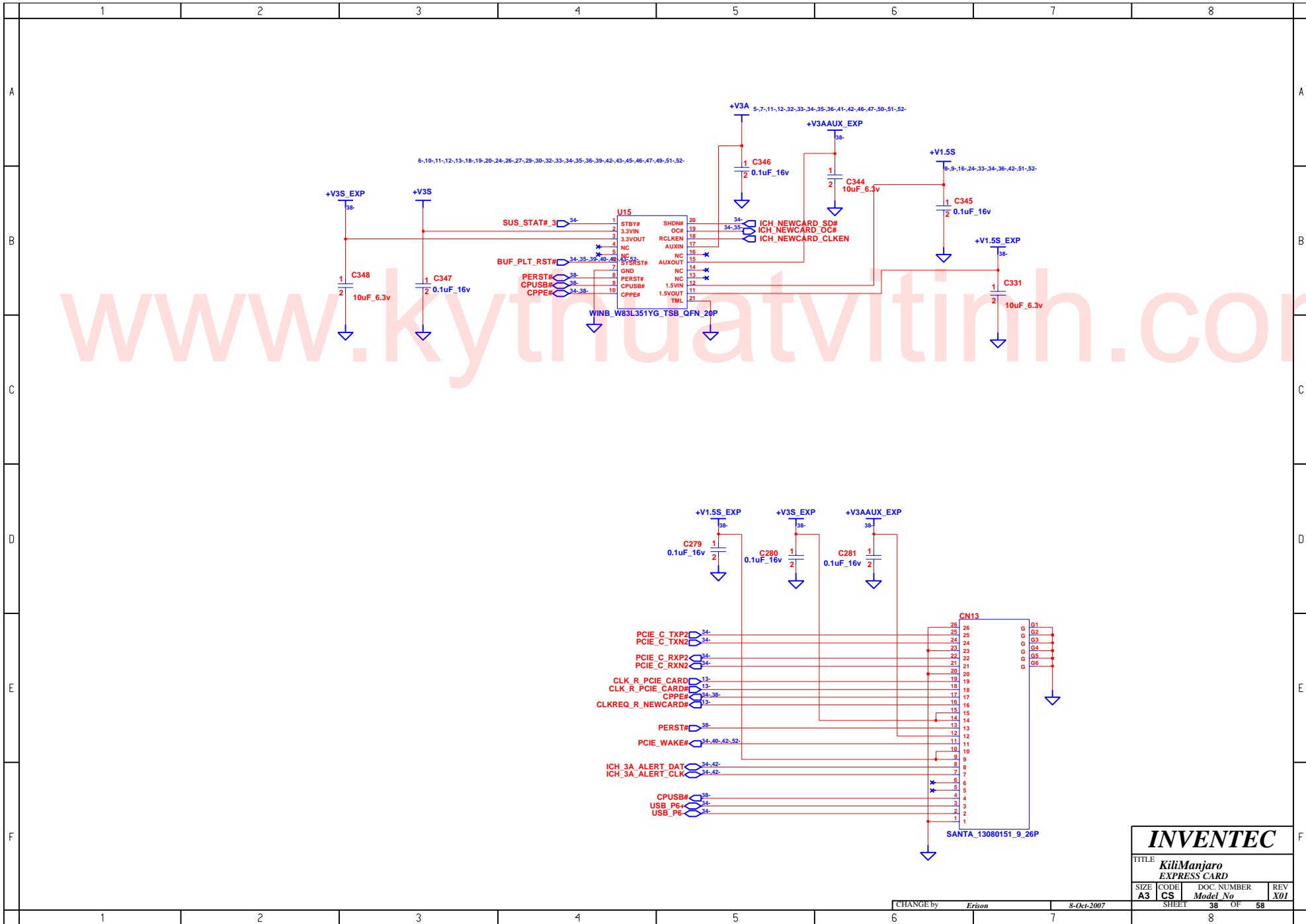

www.kytruatvitinh.com

INVENTEC			
TITLE KiliManjaro EXPRESS CARD			
SIZE A3	CODE CS	DOC. NUMBER <i>Model No</i>	REV X01
CHANGE by <i>Erison</i>		8-Oct-2007	
SHEET 38		OF 58	

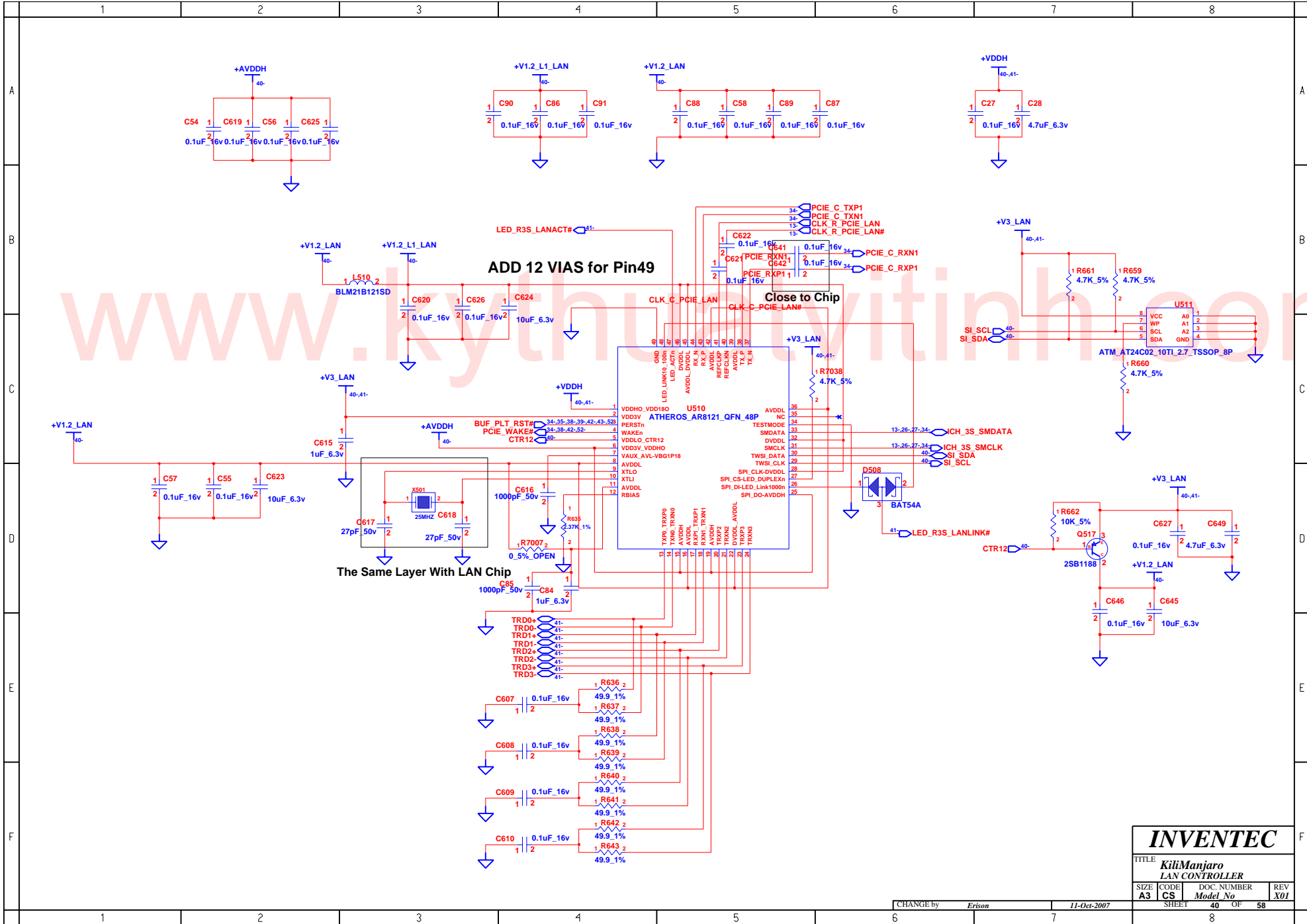

INVENTEC			
TITLE KiliManjaro LAN CONTROLLER			
SIZE A3	CODE CS	DOC. NUMBER Model No	REV X01
CHANGE by <i>Erison</i>		11-Oct-2007	
SHEET 40		OF 58	

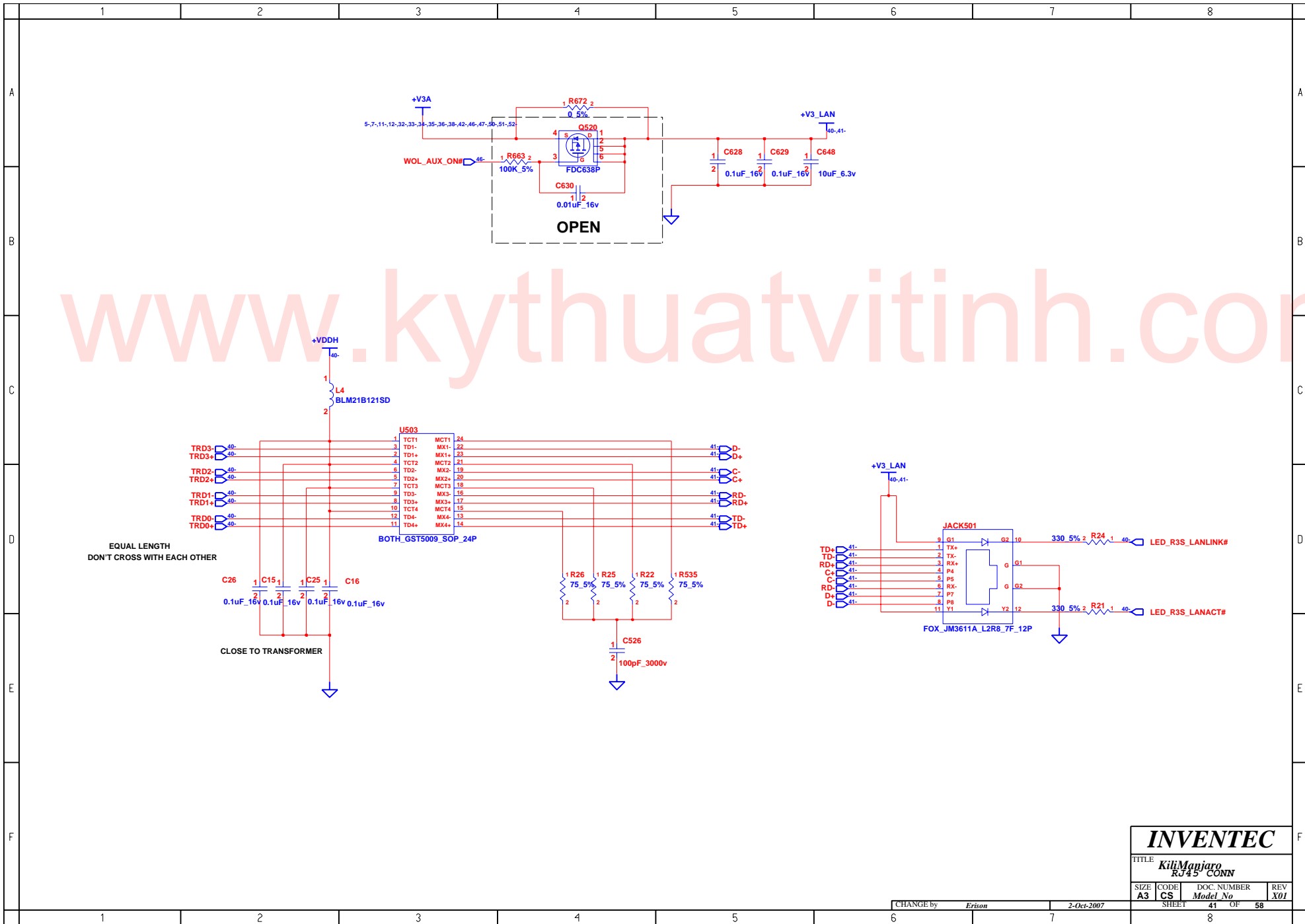

INVENTEC			
TITLE <i>KiliManjaro</i> RJ45 CONN			
SIZE A3	CODE CS	DOC. NUMBER <i>Model No</i>	REV X01
CHANGE by <i>Erison</i>		2-Oct-2007	
SHEET 41		OF 58	

www.kythuatinh.com

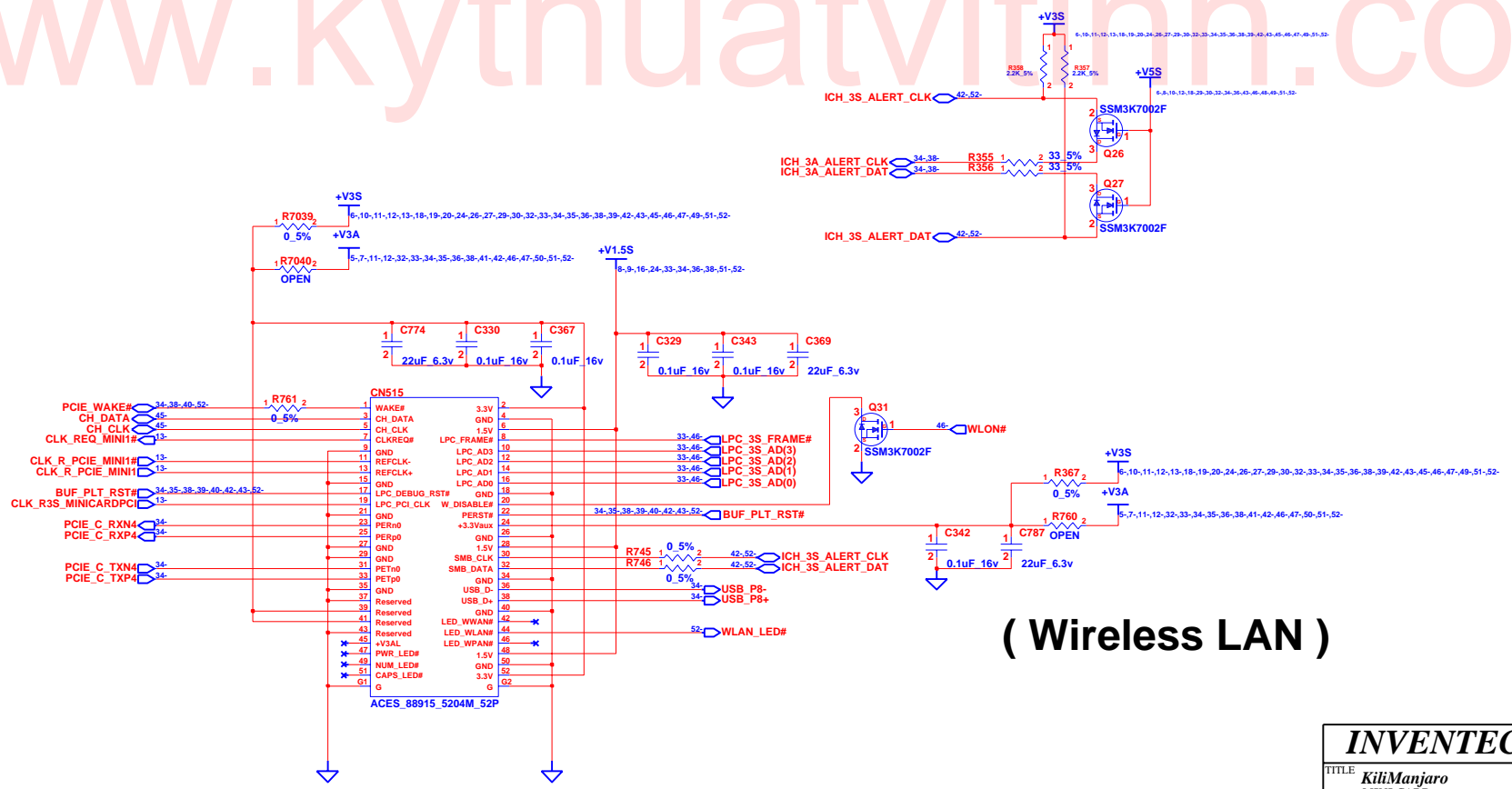

(Wireless LAN)

INVENTEC			
TITLE <i>KiliManjaro MINI CARD</i>			
SIZE A3	CODE CS	DOC. NUMBER <i>Model No</i>	REV X01
CHANGE by <i>Erison</i>		2-Oct-2007	
SHEET 42		OF 58	

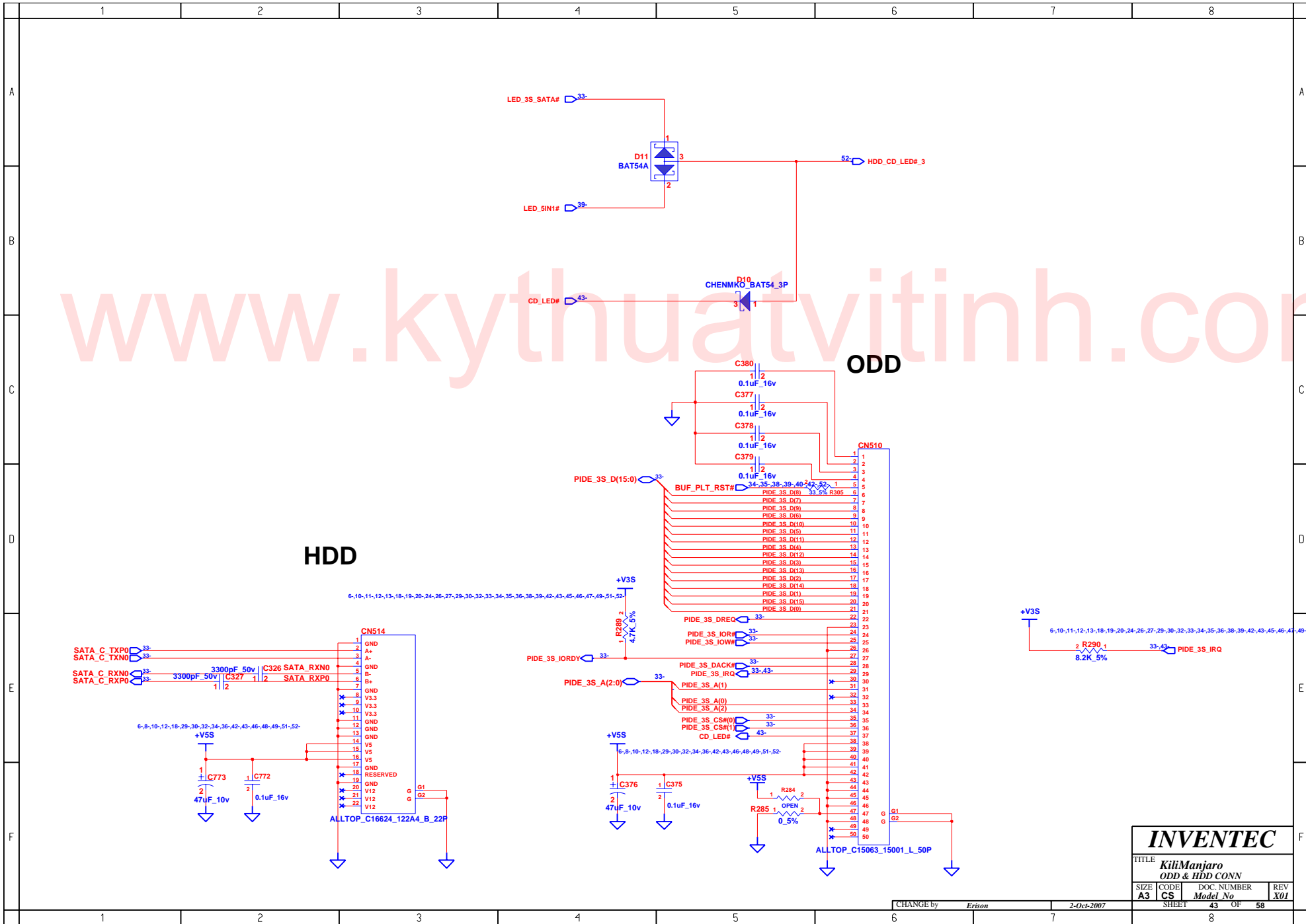

INVENTEC			
TITLE KiliManjaro ODD & HDD CONN			
SIZE A3	CODE CS	DOC. NUMBER <i>Model No</i>	REV X01
CHANGE by <i>Erison</i>		2-Oct-2007	
SHEET 43		OF 58	

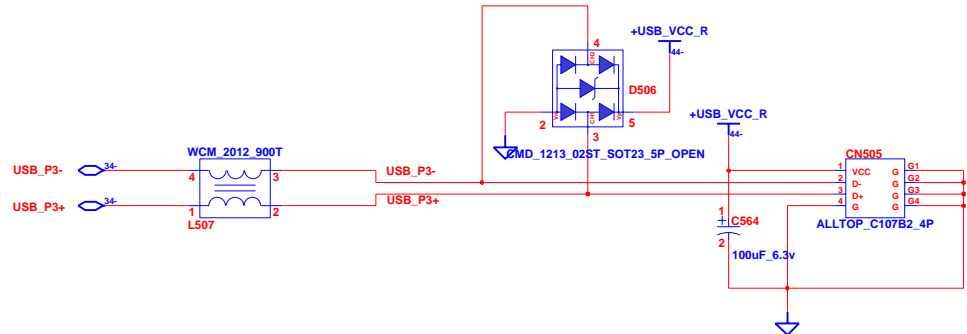
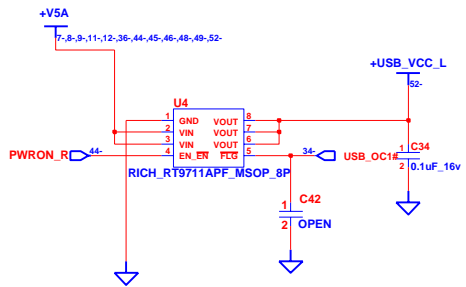
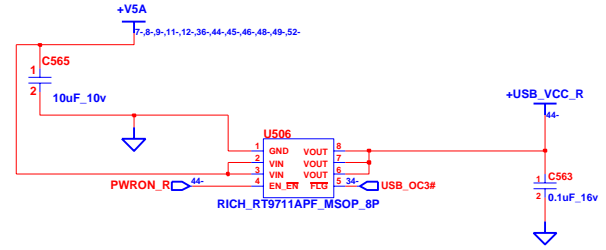
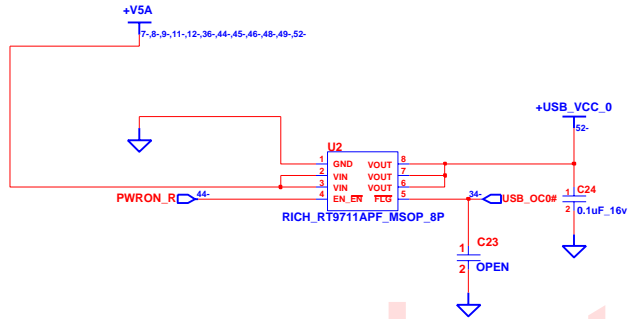

SLP_SS#_3R 34-46- R43 1 2 0.5%
 USB_PWRON 46- R45 1 2 0.5% OPEN

USB POWER STATE	S0	S3	S5
AC MODE	ON	ON	OFF
DC MODE	ON	ON	OFF

www.kythuatvithinh.com

INVENTEC			
TITLE KiliManjaro USB CONN			
SIZE A3	CODE CS	DOC. NUMBER 44	REV X01
CHANGE by Erison		11-Jan-2008	
SHEET 44		OF 58	

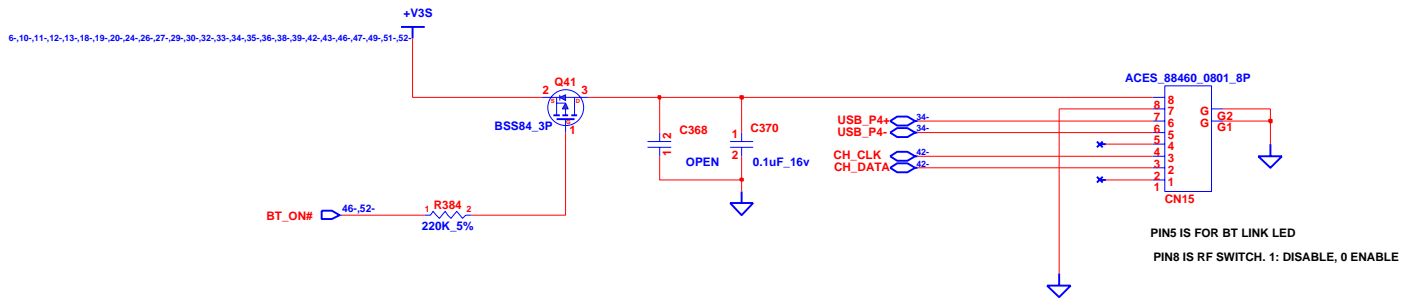

BLUE TOOTH

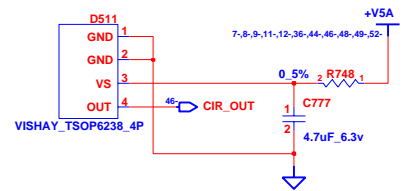

CIR

www.kythuatchitinh.com

INVENTEC			
TITLE KiliManjaro BLUETOOTH			
SIZE A3	CODE CS	DOC. NUMBER 45	REV X01
CHANGE by <i>Erison</i>		2-Oct-2007	
SHEET		OF 58	

	1	2	3	4	5	6	7	8
A								
B								
C								
D								
E								
F								
	1	2	3	4	5	6	7	8

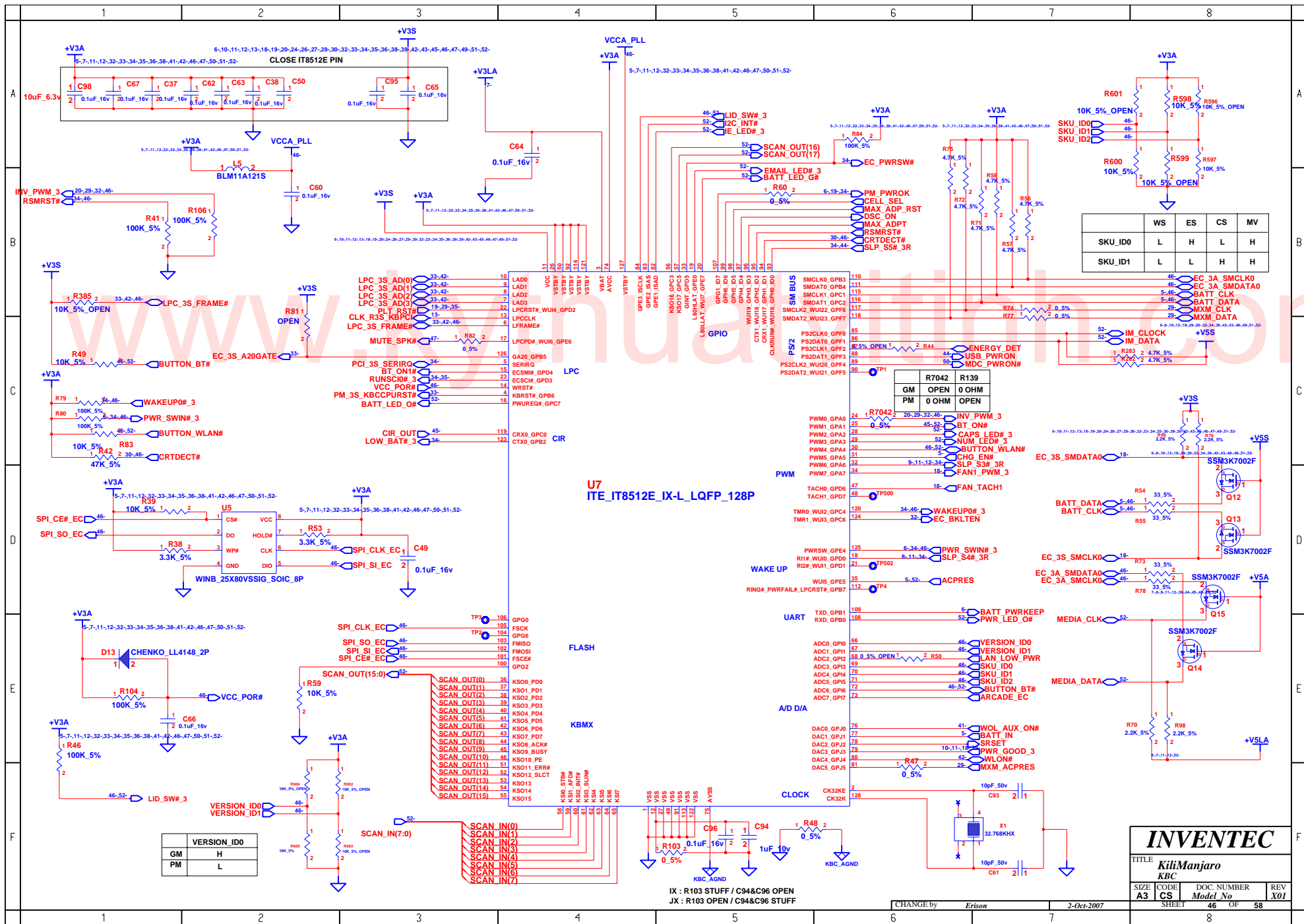

	WS	ES	CS	MV
SKU_ID0	L	H	L	H
SKU_ID1	L	L	H	H
SKU_ID2				

GM	OPEN	0 OHM
PM	0 OHM	OPEN

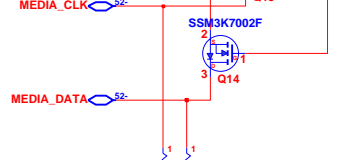
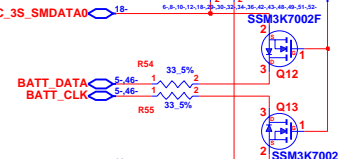

INVENTEC

TITLE: **KiliManjaro KBC**

SIZE: **A3 CS** CODE: **Model No** DOC. NUMBER: **46** REV: **X01**

IX : R103 STUFF / C94&C96 OPEN
 JX : R103 OPEN / C94&C96 STUFF

CHANGE by: *Erison* 2-Oct-2007

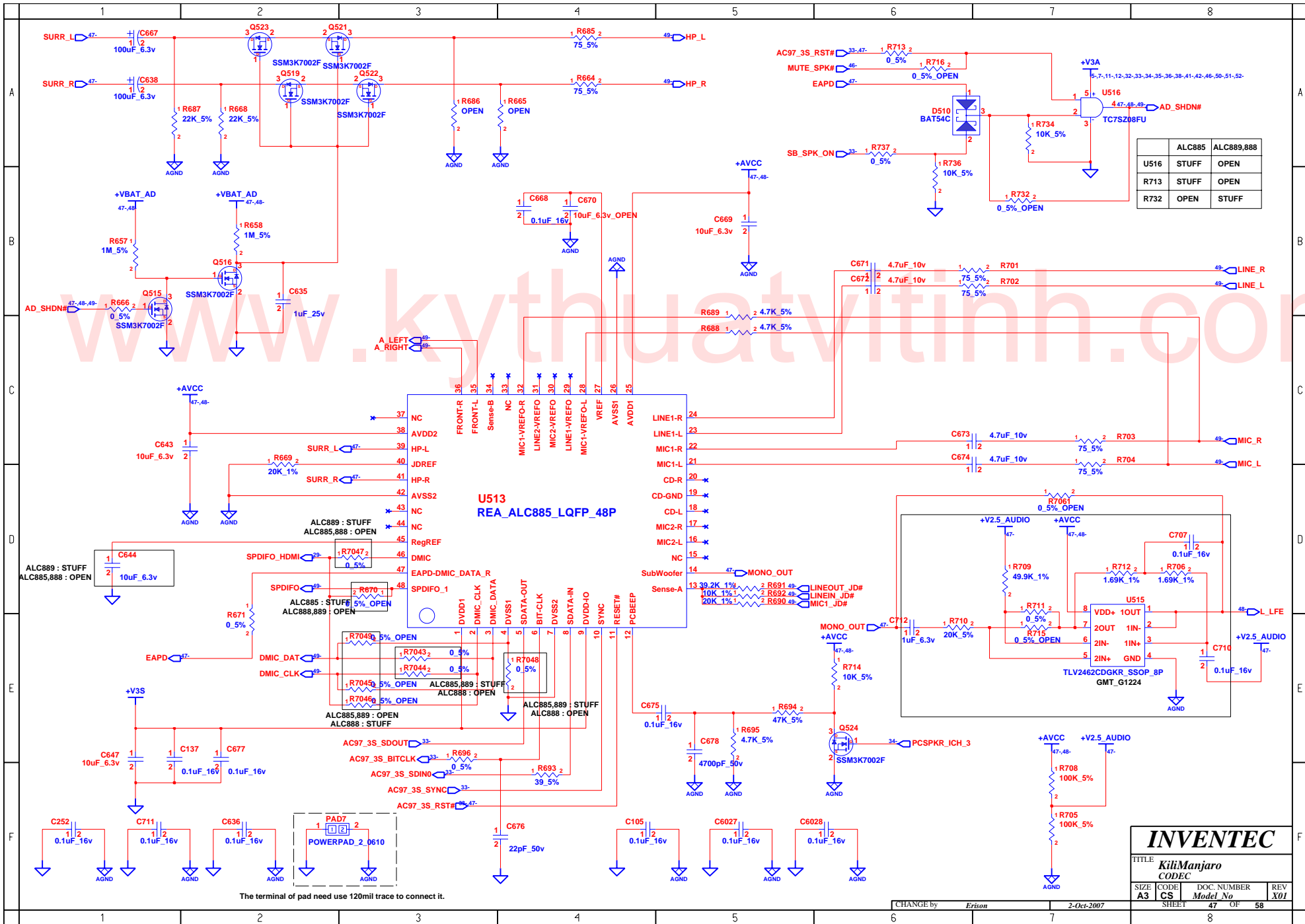

	ALC885	ALC889,888
U516	STUFF	OPEN
R713	STUFF	OPEN
R732	OPEN	STUFF

INVENTEC			
TITLE: KiliManjaro CODEC			
SIZE: A3	CODE: CS	DOC. NUMBER: Model No	REV: X01
SHEET: 47		OF: 58	

The terminal of pad need use 120mil trace to connect it.

CHANGE by: Erison 2-Oct-2007

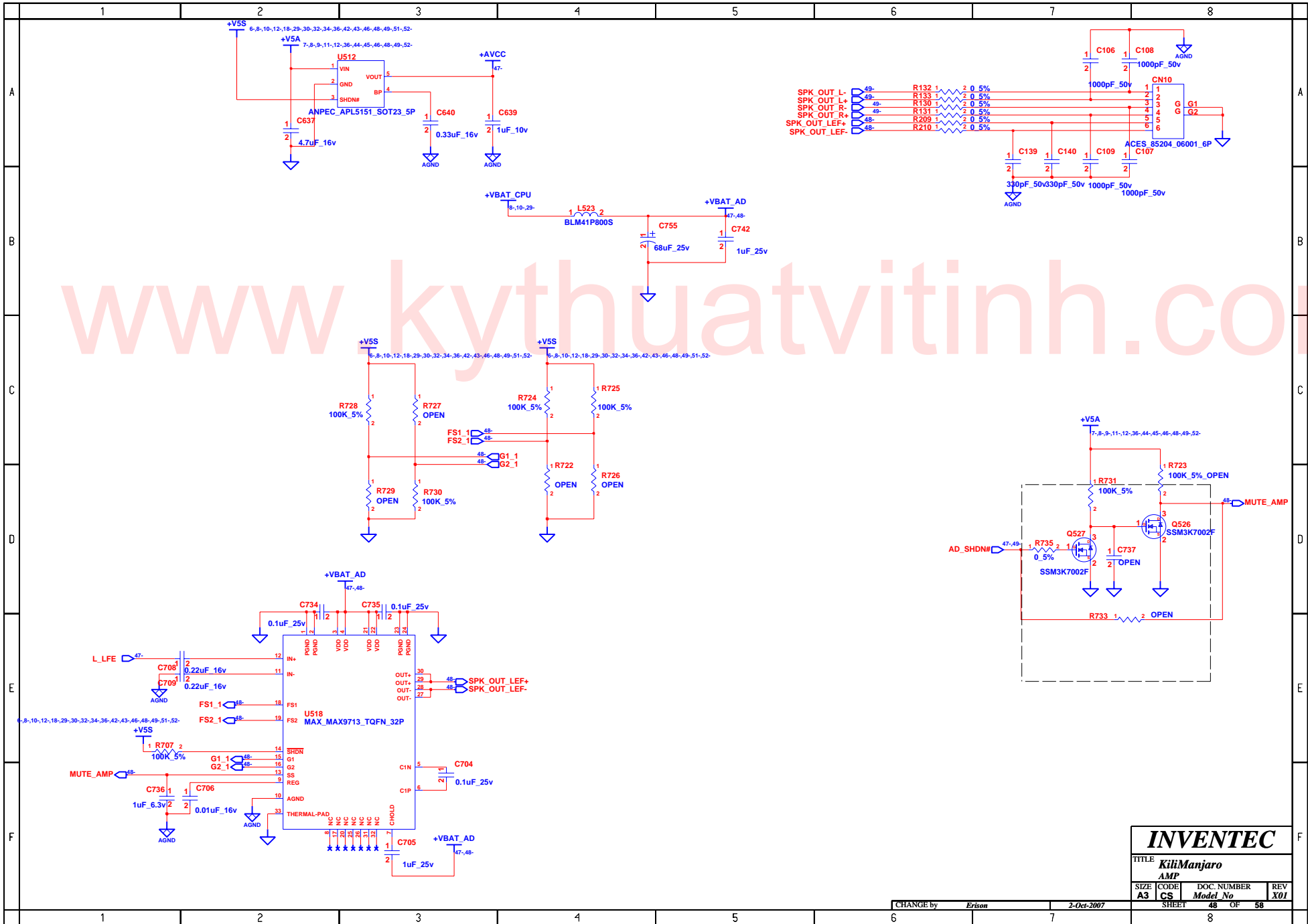

INVENTEC			
TITLE KiliManjaro			
AMP			
SIZE A3	CODE CS	DOC. NUMBER Model No	REV X01
CHANGE by Erison		2-Oct-2007	
SHEET 48		OF 58	

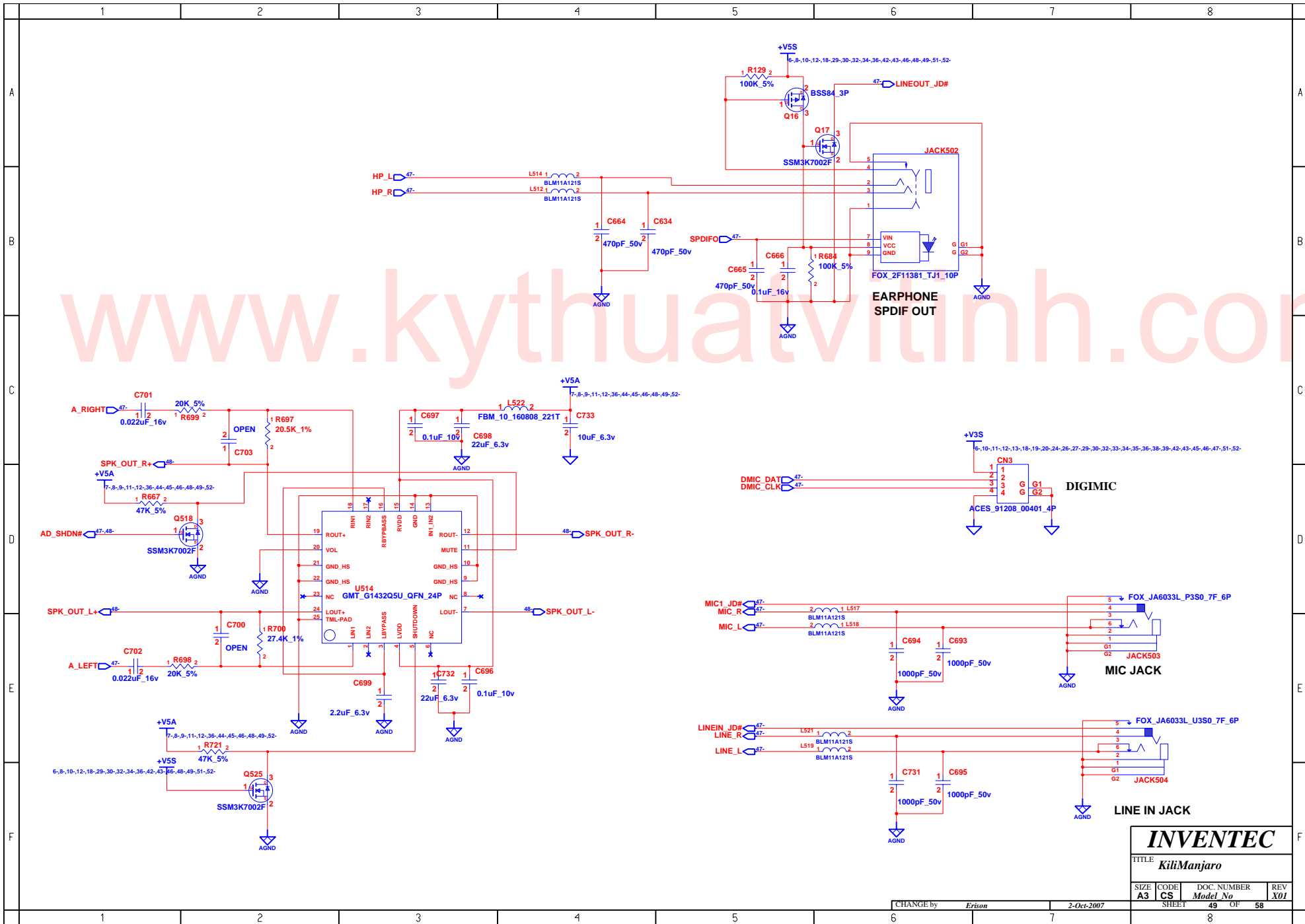

INVENTEC			
TITLE <i>KiliManjaro</i>			
SIZE A3	CODE CS	DOC. NUMBER <i>Model No</i>	REV X01
CHANGE by <i>Erison</i>		2-Oct-2007	
SHEET 49		OF 58	

www.kythuatvithinh.com

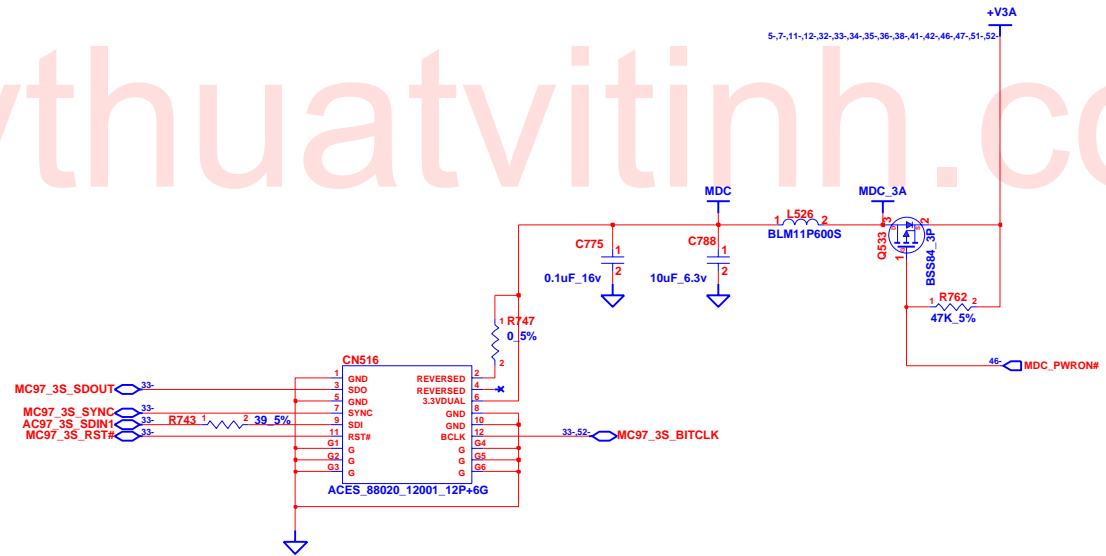

INVENTEC

TITLE			
KiliManjaro			
MDC			
SIZE	CODE	DOC. NUMBER	REV
A3	CS	Model No	X01
SHEET		50	OF 58

CHANGE by Erison 8-Oct-2007

IO BOARD

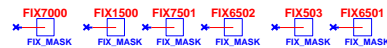
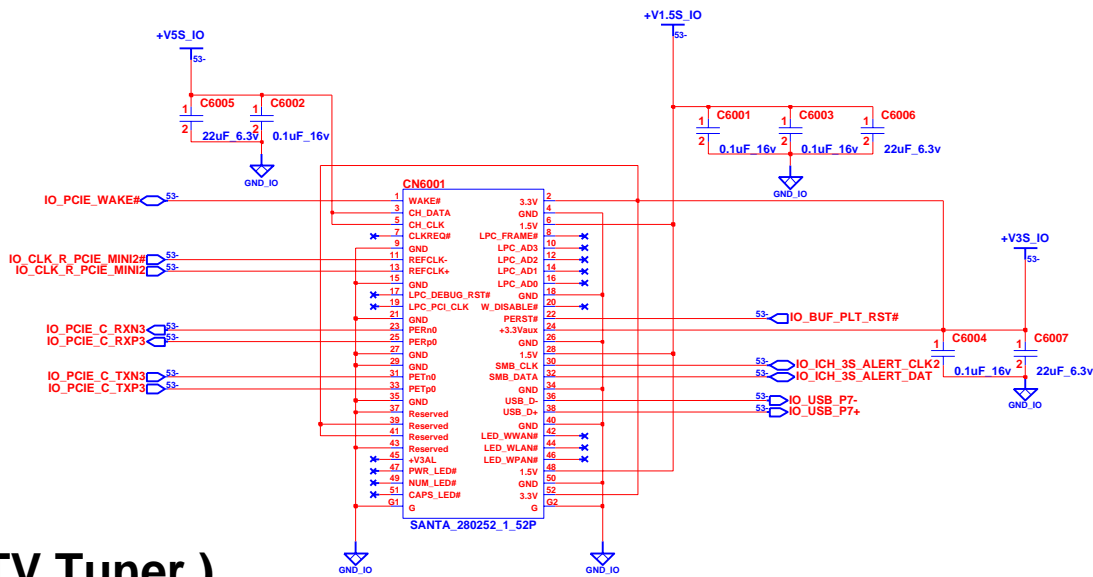
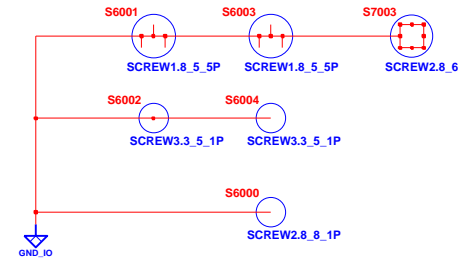
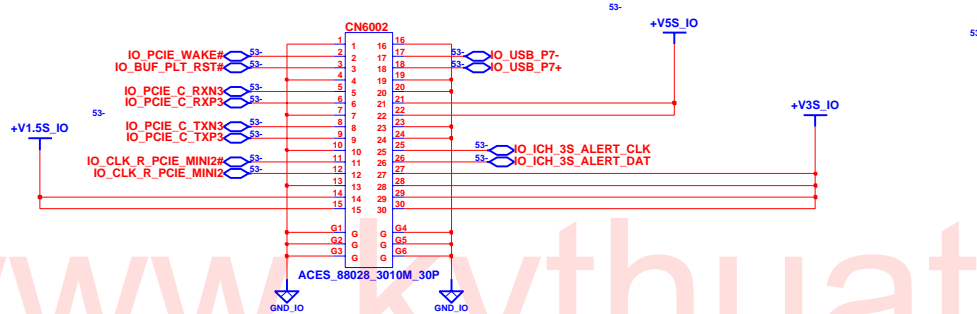

(TV Tuner)

INVENTEC

TITLE
**KiliManjaro
MEDIA BOARD**

SIZE A3	CODE CS	DOC. NUMBER Model No	REV X01
-------------------	-------------------	-------------------------	-------------------

CHANGE by *Erison* 11-Jan-2008

SHEET 53 OF 58

USB & TV BOARD

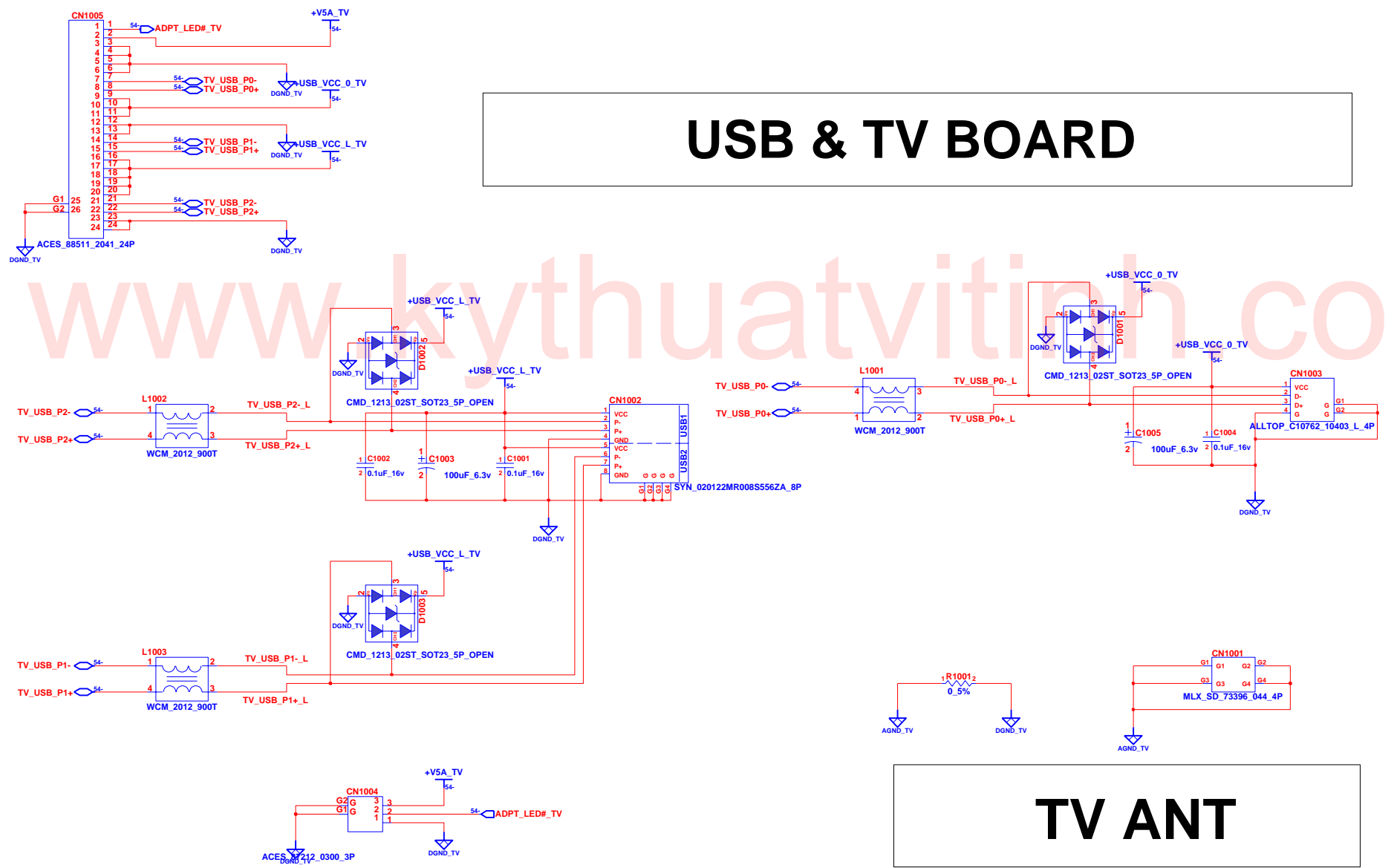

TV ANT

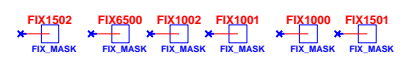

INVENTEC			
TITLE KiliManjaro USB & TV BOARD			
SIZE A3	CODE CS	DOC. NUMBER Model No	REV X01
CHANGE by Erison		25-Nov-2007	
SHEET 54		OF 58	

HINGE LED Board 1

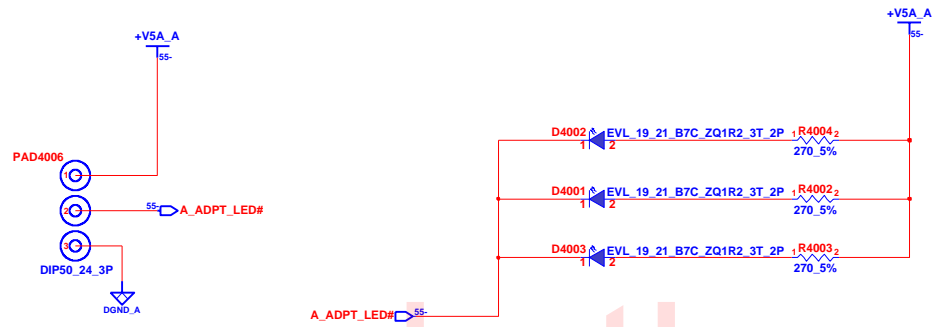

HINGE LED Board 2

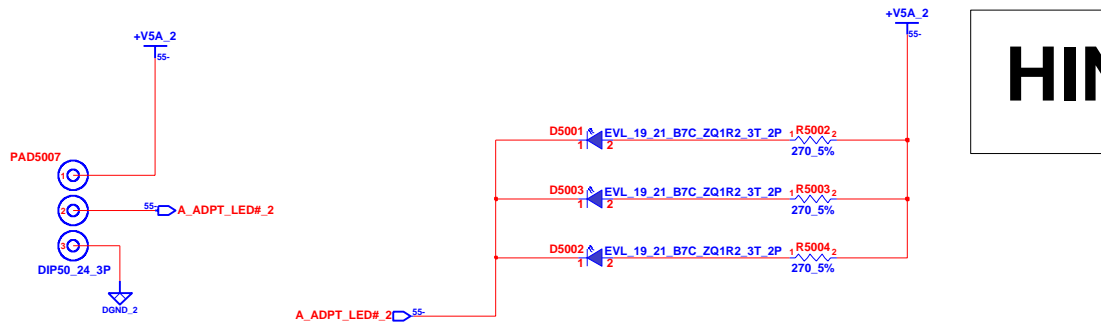

INVENTEC

TITLE			
KiliManjaro LED BOARD			
SIZE	CODE	DOC. NUMBER	REV
A3	CS	Model No	X01

PowerButton Board

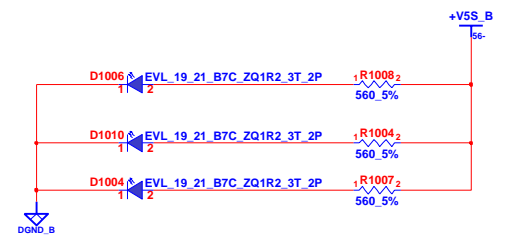
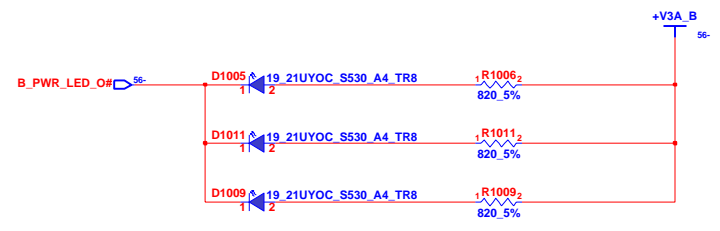
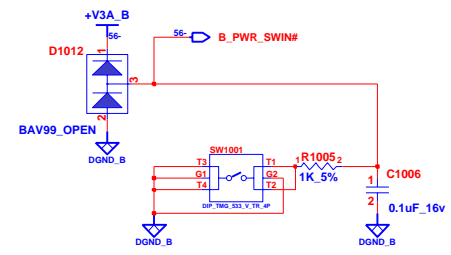
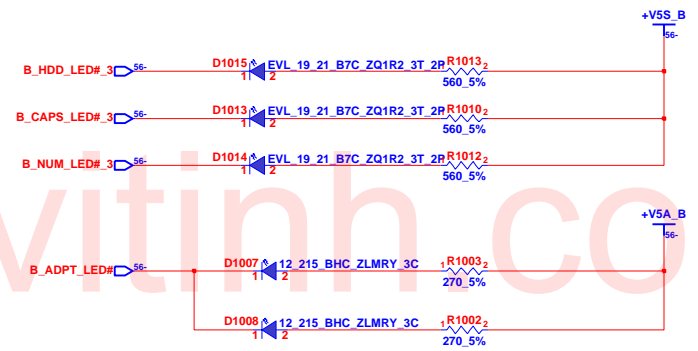
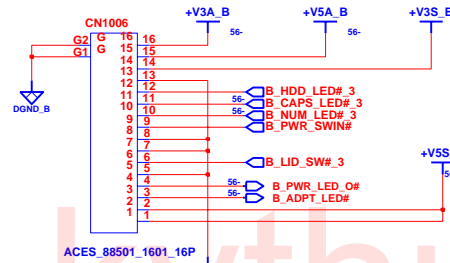

LID SWITCH

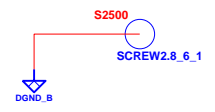

INVENTEC			
TITLE KiliManjaro PowerButton Board			
SIZE A3	CODE CS	DOC NUMBER Model No	REV X01
CHANGE by <i>Erison</i>		12-Nov-2007	
SHEET 56		OF 58	

E-KEY Board

www.kythatvithinh.com

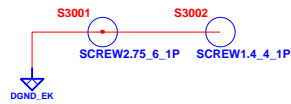
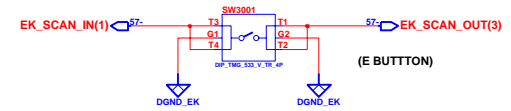
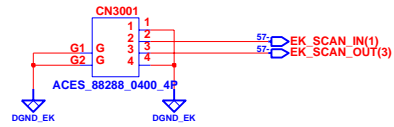

INVENTEC

TITLE			
KiliManjaro			
E-KEY BOARD			
SIZE	CODE	DOC. NUMBER	REV
A3	CS	Model No	X01
SHEET		OF	
57		OF	58

CHANGE by *Erison* 11-Jan-2008

TouchButton Board

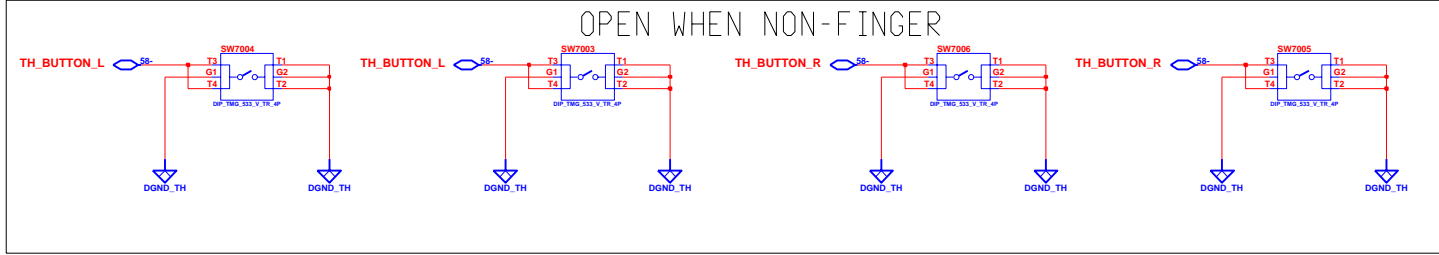
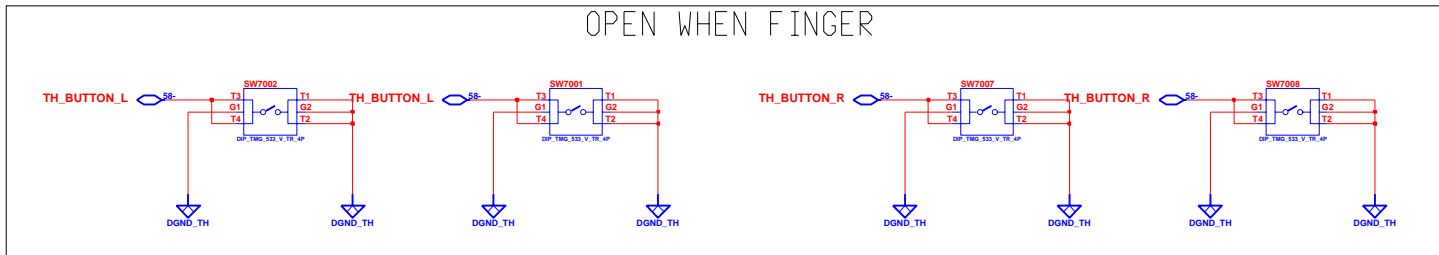
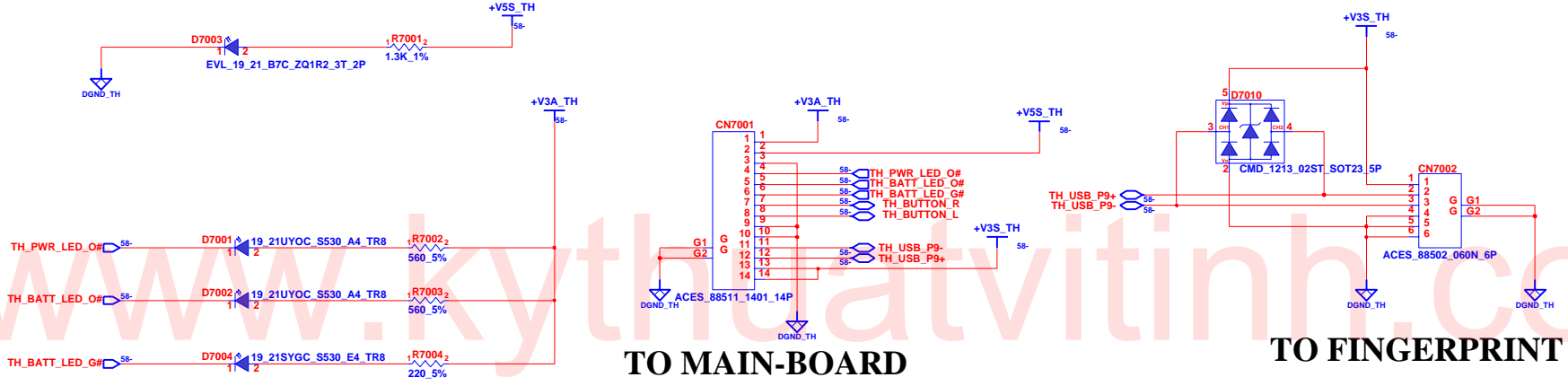

TOUCHPAD BUTTON

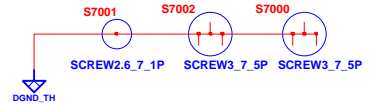

INVENTEC

TITLE			
KiliManjaro TOUCH BUTTON BOARD			
SIZE	CODE	DOC. NUMBER	REV
A3	CS	Model No	X01
SHEET		OF	
58		OF	58

CHANGE by *Erison* 22-Oct-2007

Hotkey Board

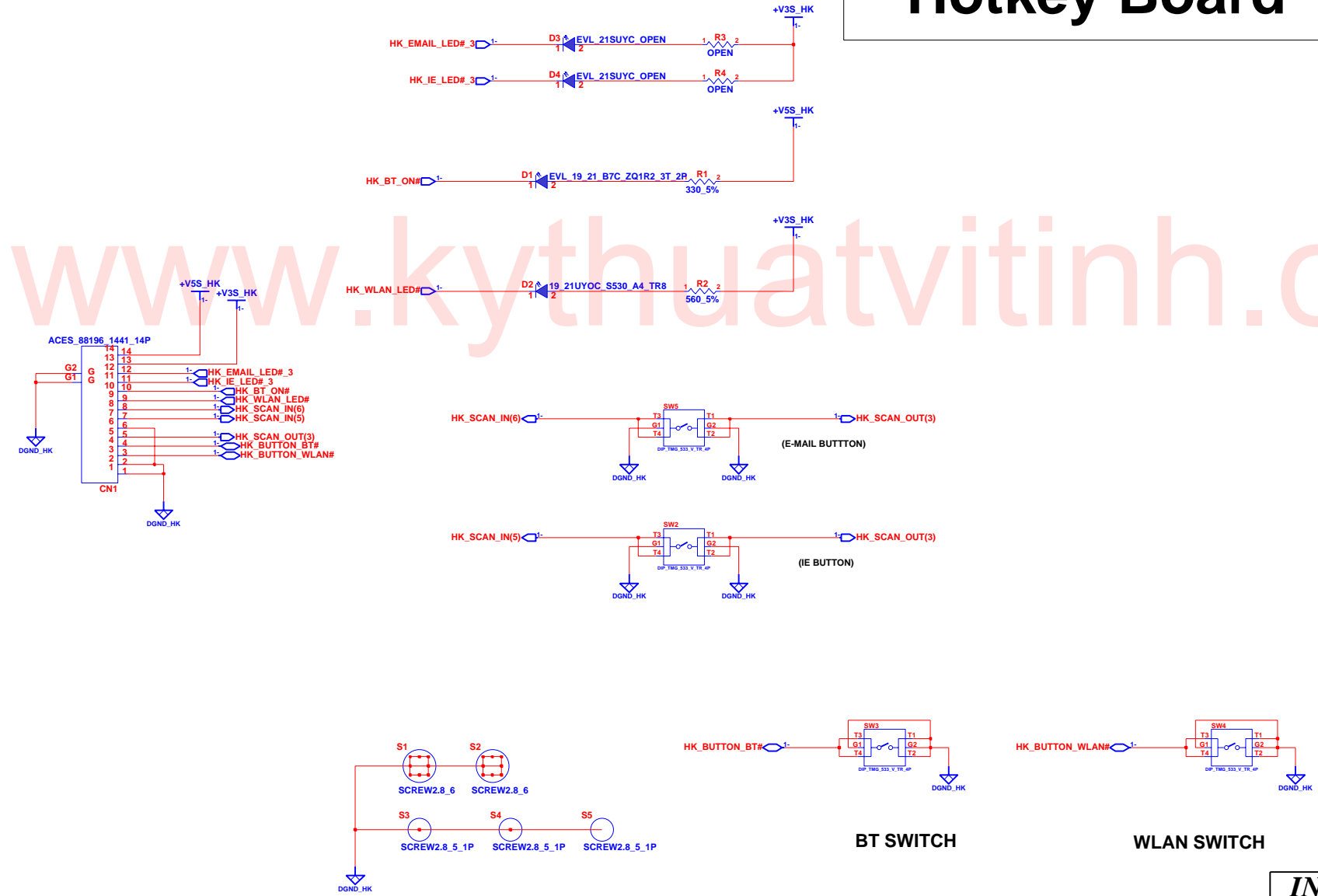

www.kythatvithinh.com

INVENTEC

TITLE			
KiliManjaro			
Hotkey Board			
SIZE	CODE	DOC. NUMBER	REV
A3	CS	Model No	X01

CHANGE by Erison 23-Oct-2007 SHEET 1 OF 1