

MODEL:	REV	CHANGE LIST	MODEL		
			ET2S	MB (LAN)	
			PAGE	FROM	TO
ET2S MB (LAN)	3A	FIRST RELEASE	1	3C	
	3B	Reference ECN :E200206-0630	2	3C	3D
	3C	Reference ECN :E200206-0675	3	3C	
	3D	Reference ECN :E200207-1262	4	3C	
			5	3C	
			6	3C	
			7	3C	
			8	3C	
			9	3C	
			10	3C	
			11	3C	
			12	3C	
			13	3C	
			14	3C	
			15	3C	
			16	3C	
			17	3C	
			18	3C	
			19	3C	
			20	3C	
			21	3C	
			22	3C	
			23	3C	
			24	3C	
			25	3C	



Quanta Computer Inc.

Project : ET2S MB(LAN)

MB Assy' P/N: 21ET2MB00C1

Document No.: 204

REV 3D

Approved by : Jacky Lee

Drawing by : CHIN HAO KUO

DATE: 2002/5/28

Cover Sheet: 1 of 1

Dr-Bios.com

ET2S SYSTEM BLOCK DIAGRAM

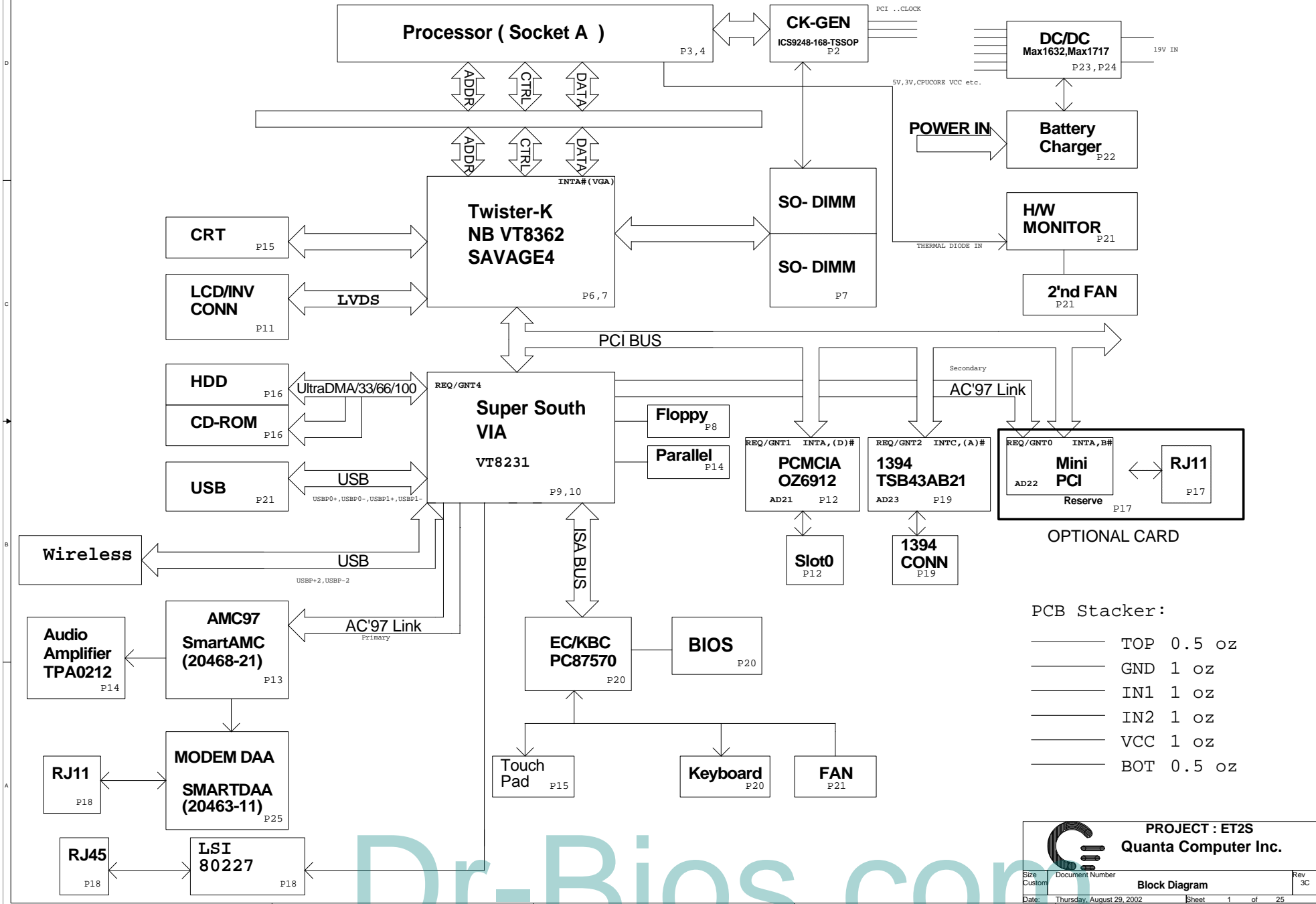

PCB Stacker:

- _____ TOP 0.5 oz
- _____ GND 1 oz
- _____ IN1 1 oz
- _____ IN2 1 oz
- _____ VCC 1 oz
- _____ BOT 0.5 oz

PROJECT : ET2S
Quanta Computer Inc.

Size Custom	Document Number	Rev 3C
Block Diagram		
Date: Thursday, August 29, 2002	Sheet	1 of 25

Dr-Bios.com

CLOCK GENERATOR

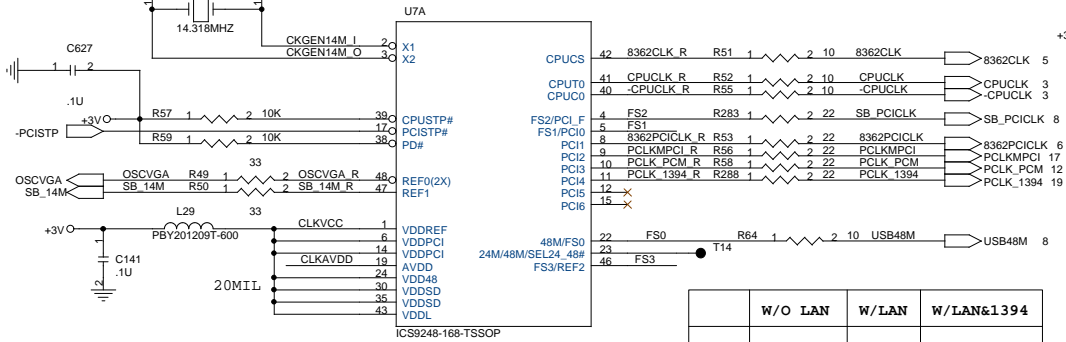

	W/O LAN	W/LAN	W/LAN&1394
R288	NC	NC	Mount

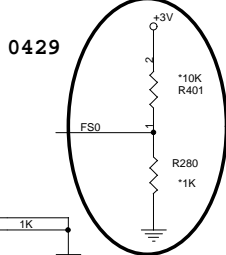

FS2	FS1	FS0	CPU	SS
1	1	1	1.33	+/-0.25%
1	1	0	1.00	+/-0.25%
1	0	1	1.33	+/-0.6%
1	0	0	1.00	+/-0.6%
0	1	1	1.33	-0.5%
0	1	0	1.00	-0.5%
0	0	1	1.33	+/-0.35%
0	0	0	1.00	+/-0.35%

DEFAULT SETTING

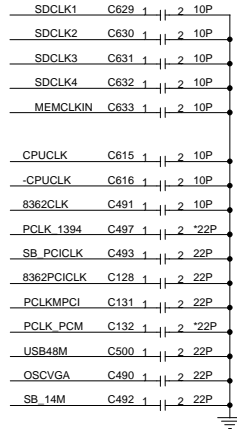

CLKVCC trace width: 30mil

- CPUCLK = Lnb-1" (0"~8")
- CPUCLK = Lnb-1" (0"~8")
- 8362CLK = Lnb (1"~9")
- MEMCLKOUT = As short as possible (1"~9")
- MEMCLKIN = Lsd+4.5" (5.5"~8.5")
- DIMCLK[1..4] = Lsd (1"~4")
- DIMCLK0 = Lsd+2.5" (3.5"~6.5")
- 8362PCICLK = Lpci +3" (4"~15")
- SB_PCICLK = Lpci +3" (4"~15")
- PCMCICLK = Lpci (1"~12")
- MINIPCICLK = Lpci (1"~12")

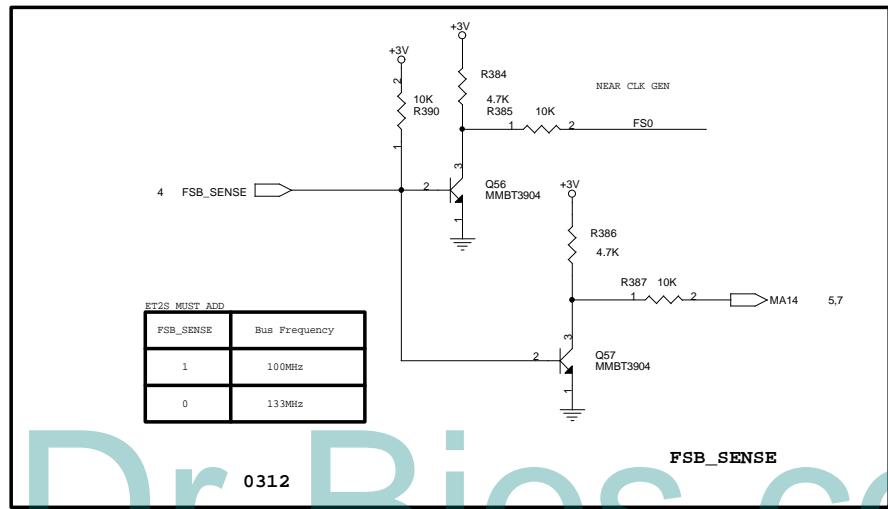

ET2S MUST ADD

FSB_SENSE	Bus Frequency
1	100MHz
0	133MHz

0312

PROJECT : ET2S
Quanta Computer Inc.

Size: Custom | Document Number: **CLOCK GENERATOR** | Rev: 3D

Date: Thursday, August 29, 2002 | Sheet: 2 of 25

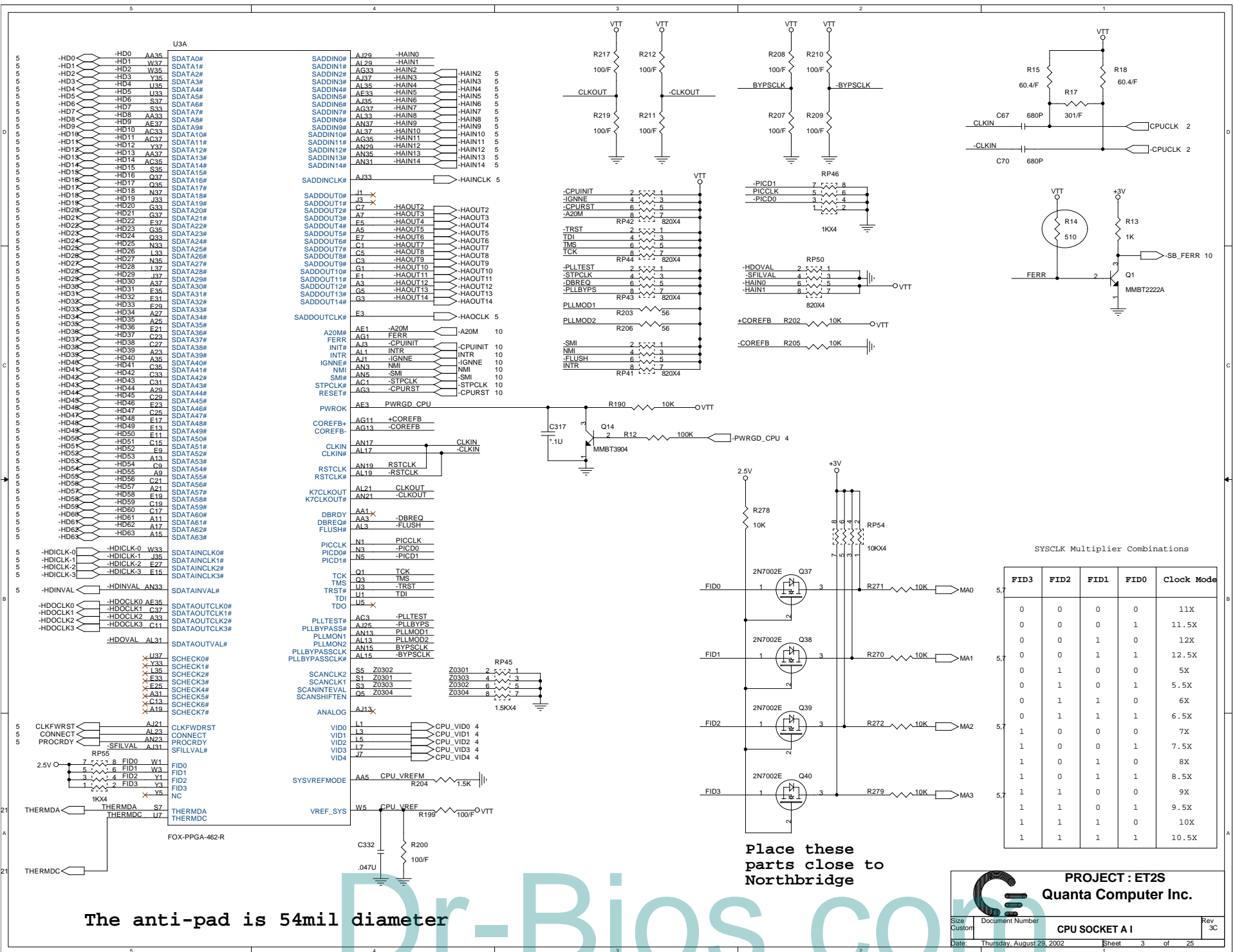

The anti-pad is 54mil diameter

Place these parts close to Northbridge

PROJECT: ET2S
Quanta Computer Inc.

Size: Custom Document Number: CPU SOCKET A I Rev: 3C

Date: Thursday, August 29, 2002 Sheet: 3 of 25



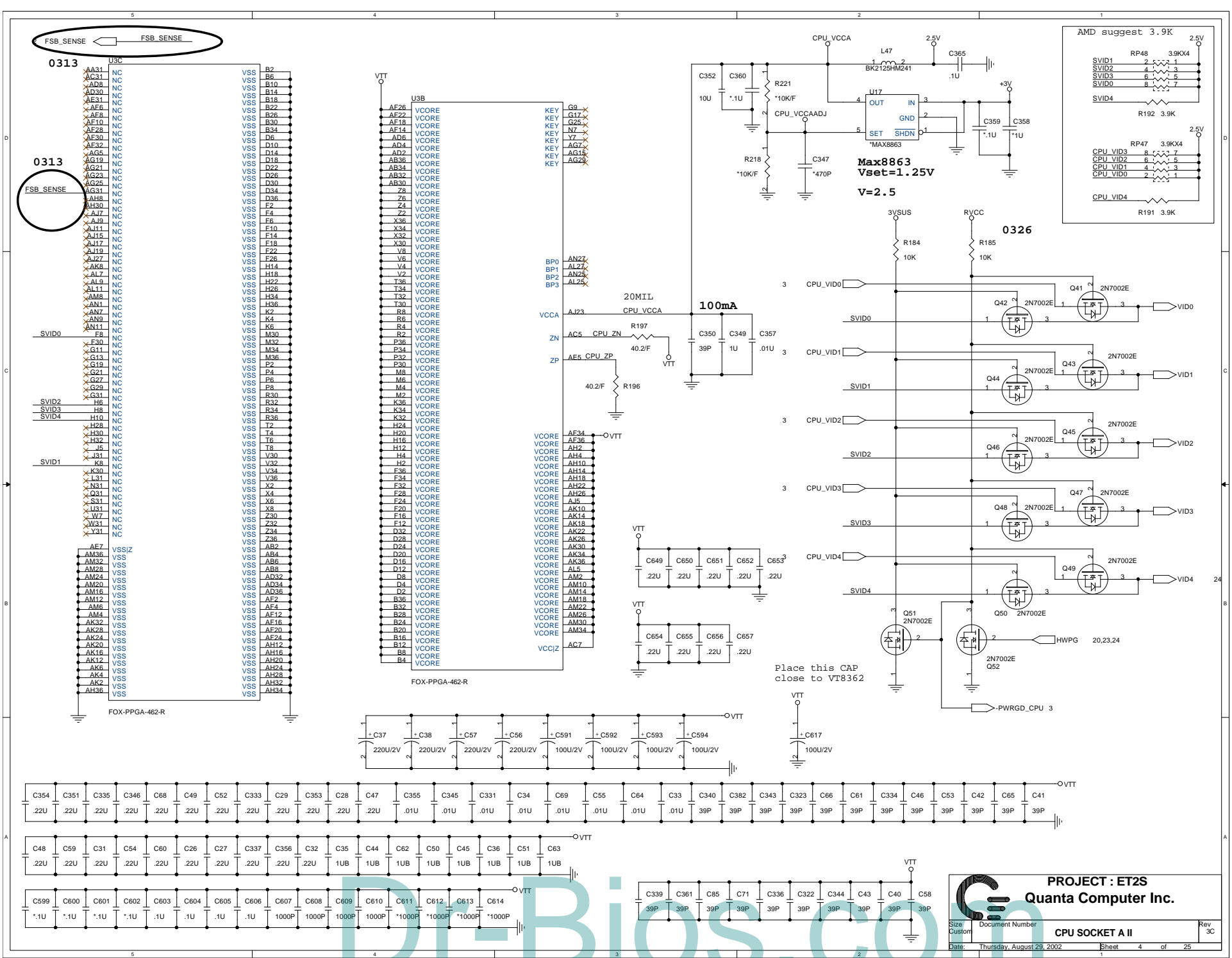

DI-BIOS.COM

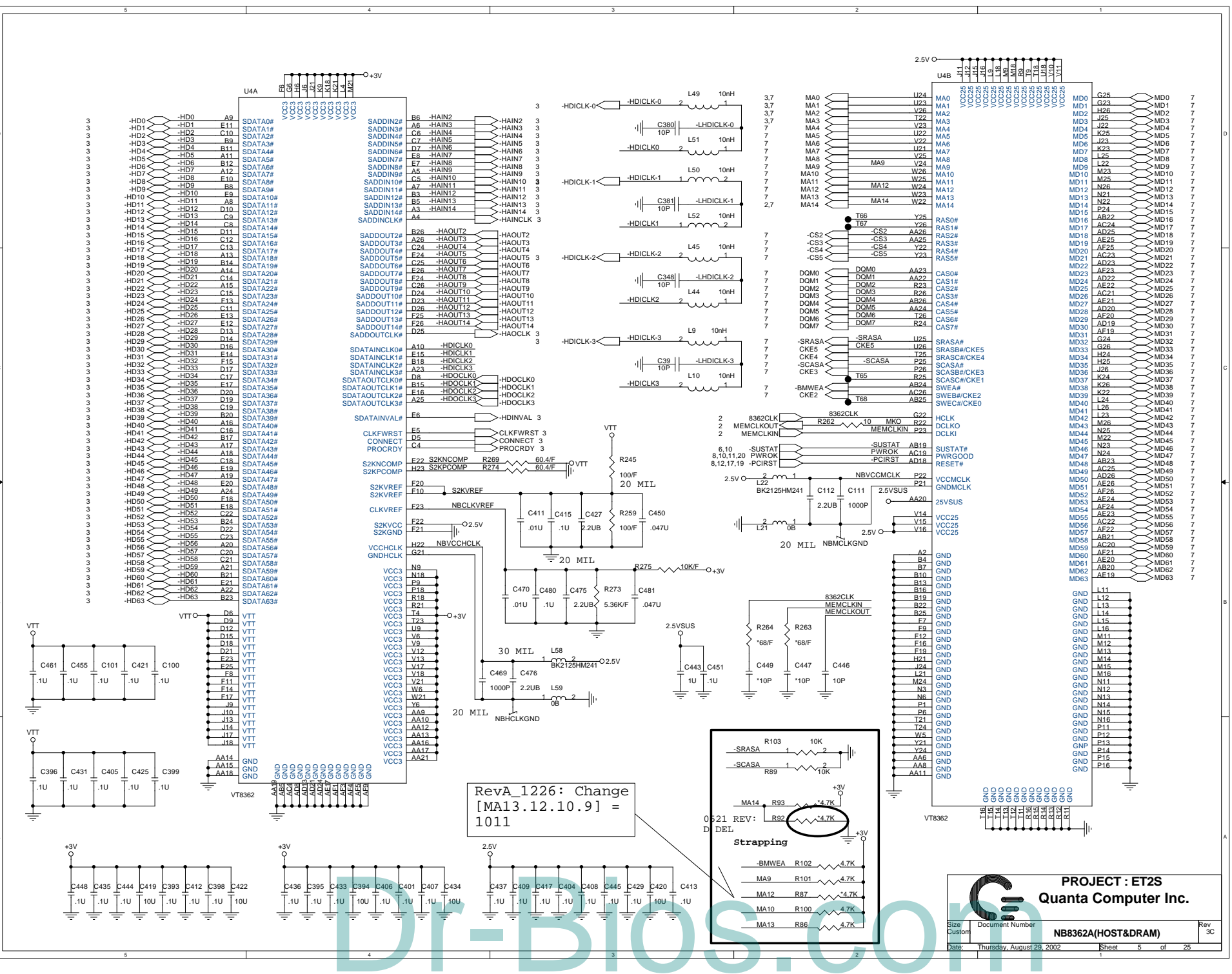

RevA_1226: Change
[MA13.12.10.9] =
1011

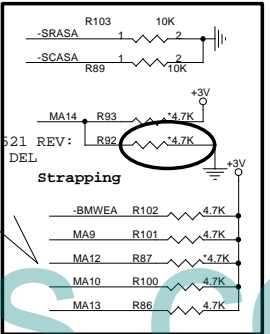

PROJECT : ET2S
Quanta Computer Inc.

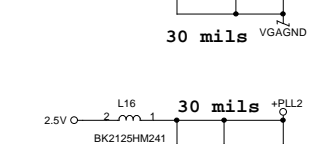
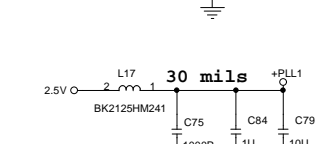
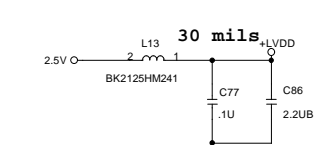
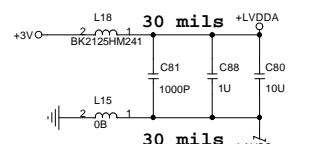
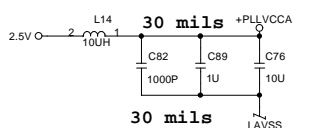
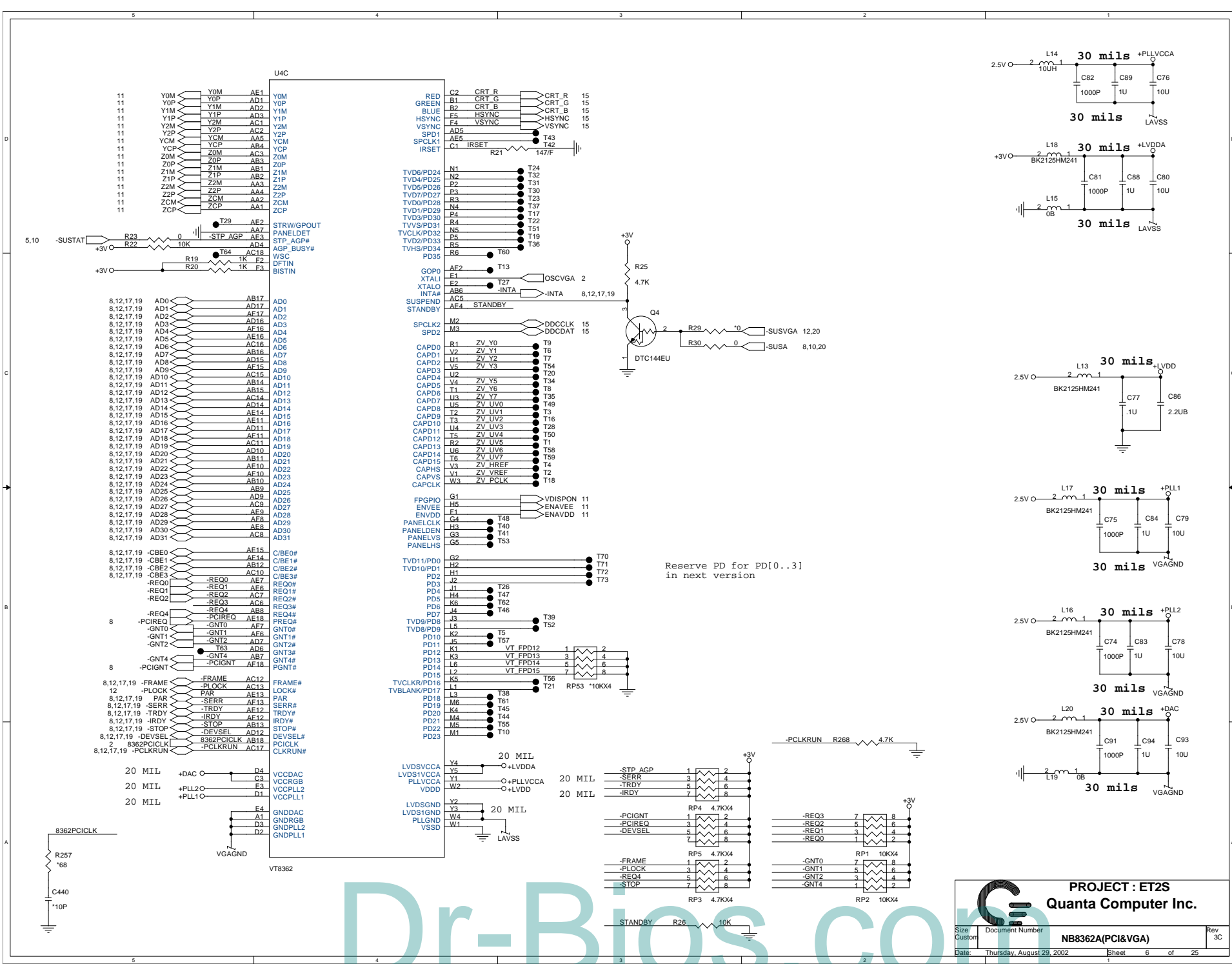

Reserve PD for PD[0..3] in next version

PROJECT : ET2S
Quanta Computer Inc.

Size: _____ Document Number: **NB8362A(PCI&VGA)** Rev: 3C
 Date: Thursday, August 29, 2002 Sheet: 6 of 25

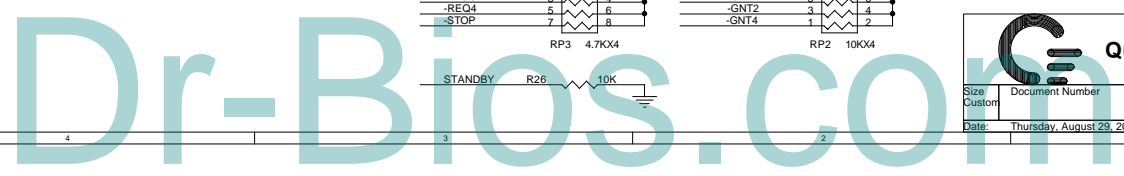

EXPANSION SO-DIMM SOCKET

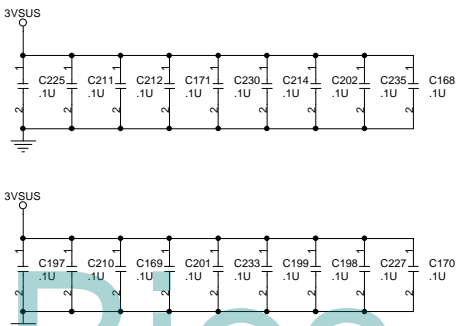
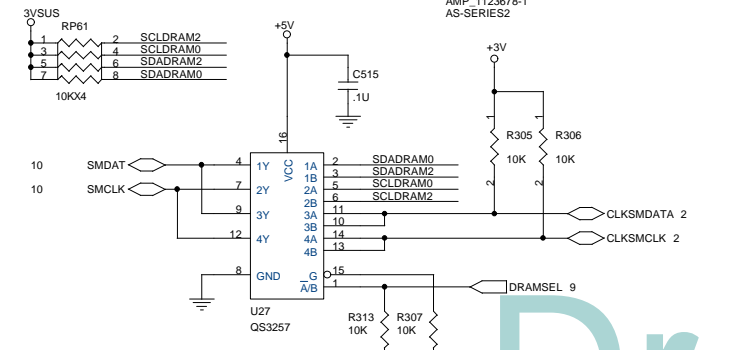
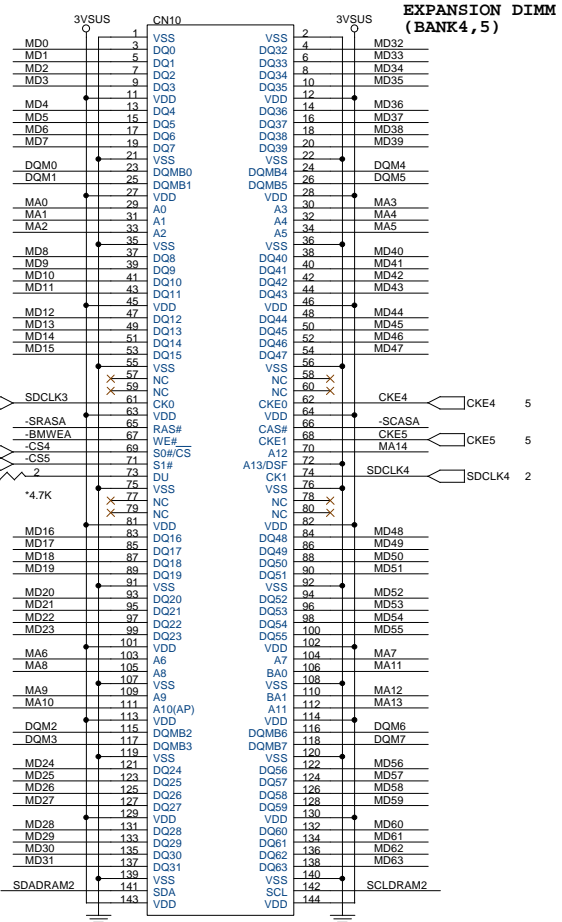
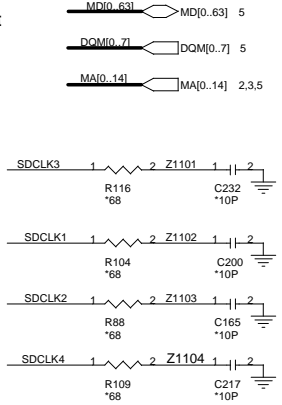
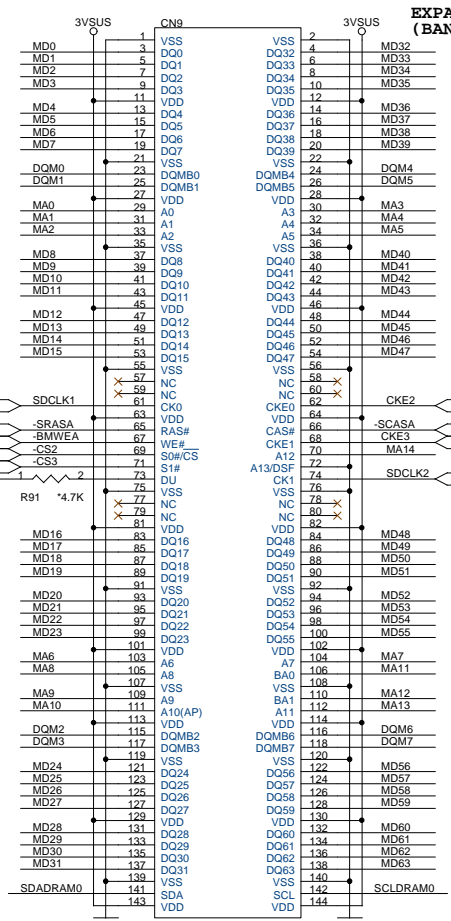

PROJECT : ET2S
Quanta Computer Inc.

Size: Custom
 Document Number: SO-DIMM
 Date: Thursday, August 29, 2002
 Sheet: 7 of 25
 Rev: 3C

Dr-BIOS.com

Power-On Configuration Strapping Pins

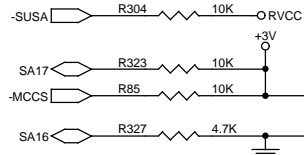

-MCCS(High):Disable AMD CPU Frequency Strapping
 SA17(High):Disable auto reboot
 SA16(High):Disable LPC
 -SUSA(High):Select Socket A

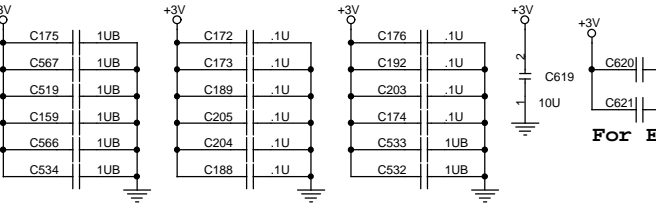
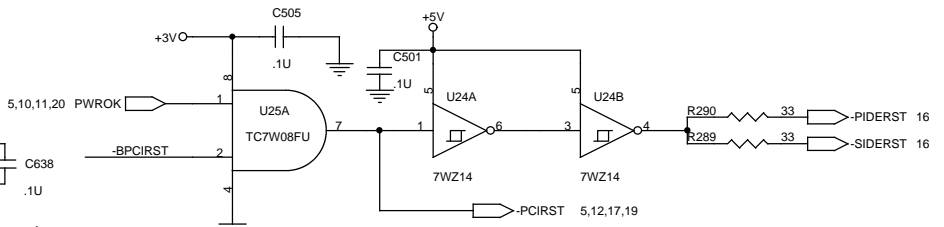

For EMI

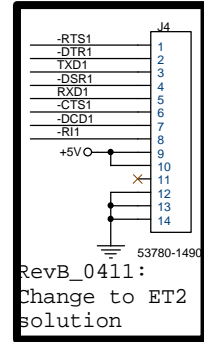
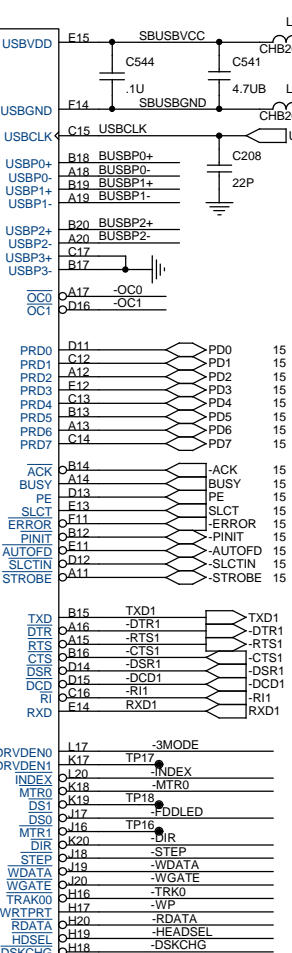
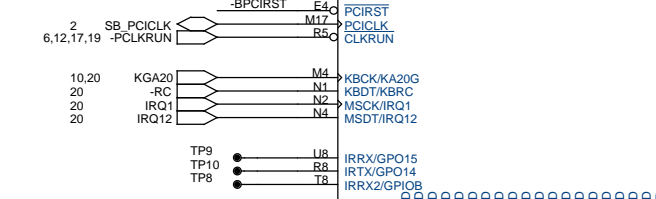
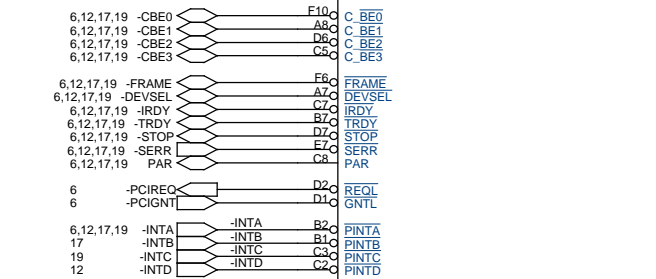
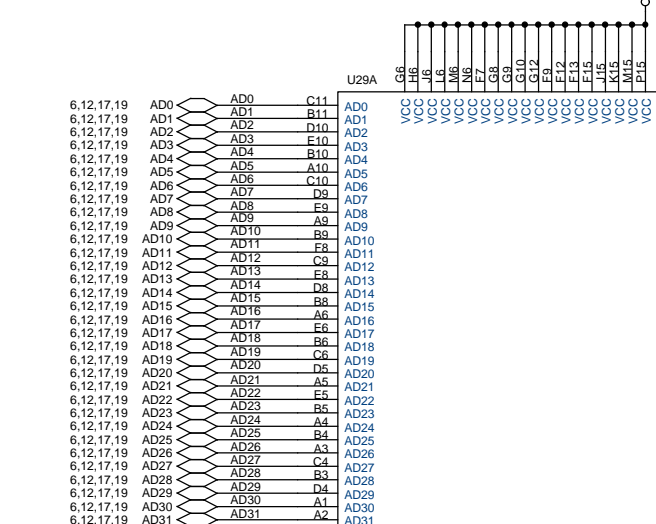

RevB_0411:
 Change to ET2
 solution

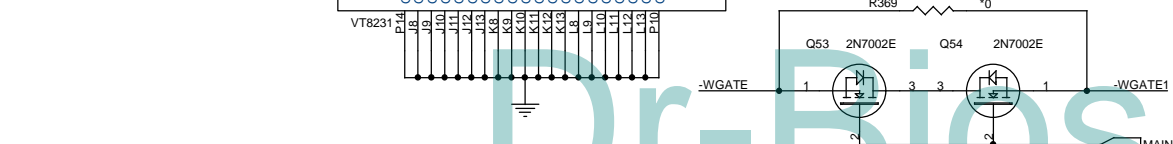
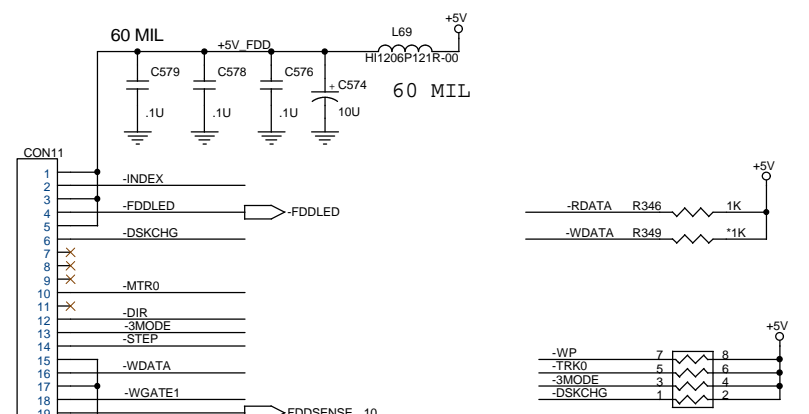
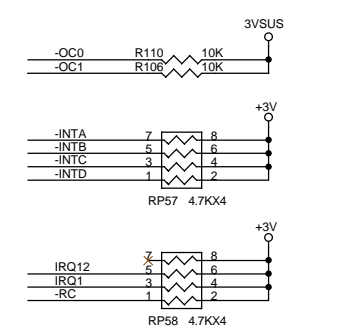
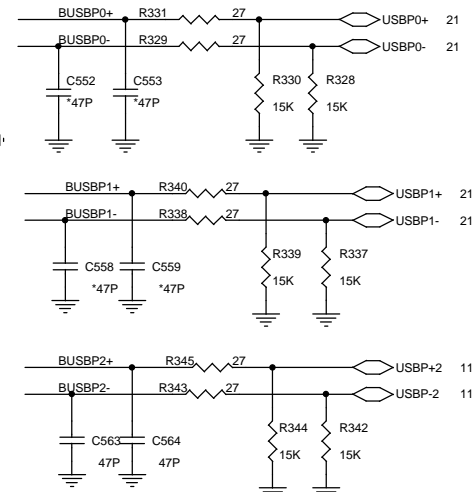

PROJECT : ET2S
Quanta Computer Inc.

Size Document Number
VT8231 PCI&USB&IO Rev 3C

Date: Thursday, August 29, 2002 Sheet 8 of 25

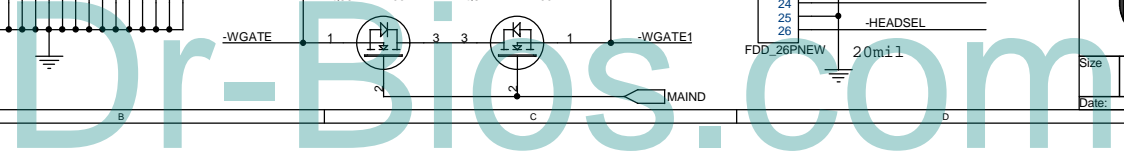

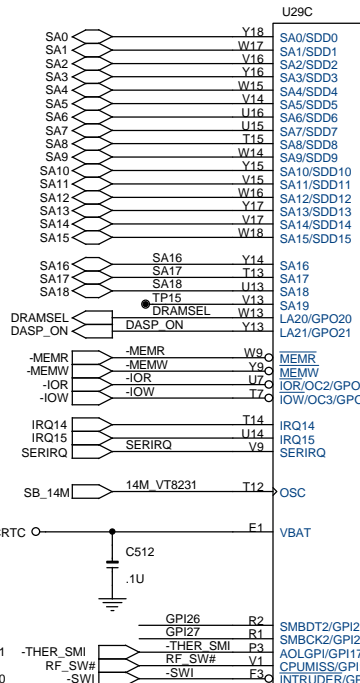
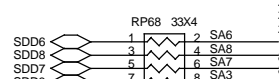
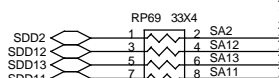
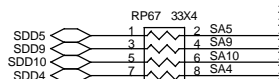
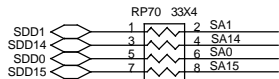

RevA_1224
Modified

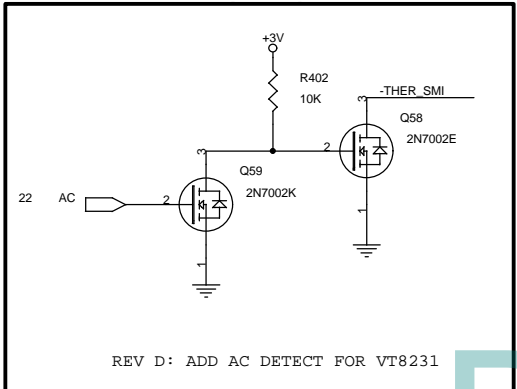
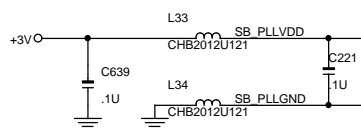

REV D: ADD AC DETECT FOR VT8231

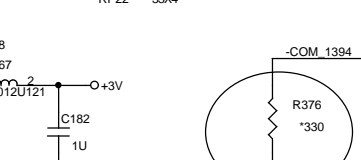
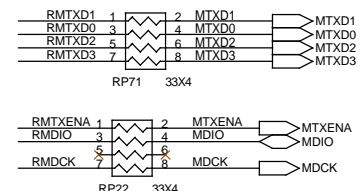
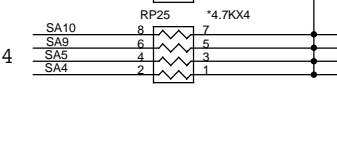
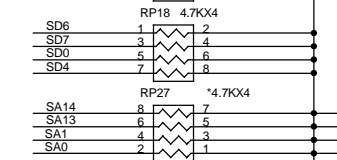
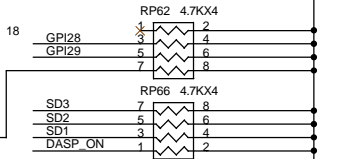
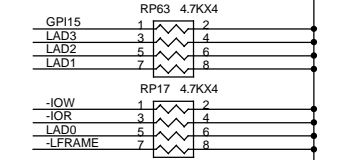
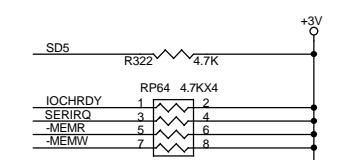
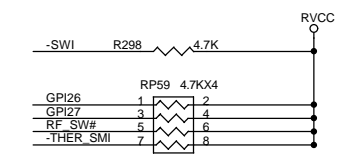
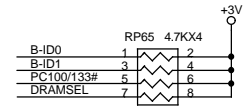
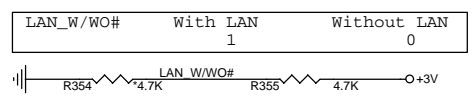
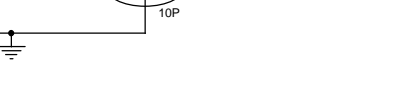
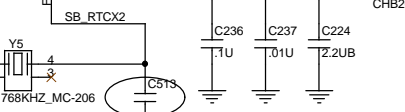
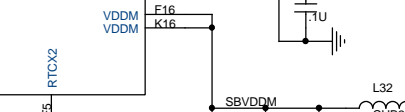
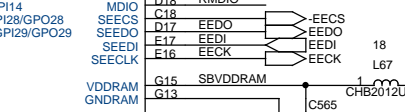
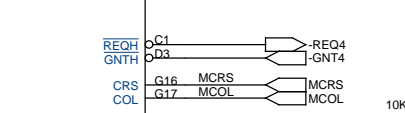
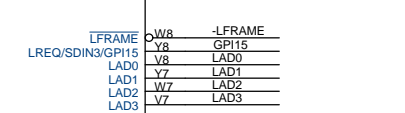
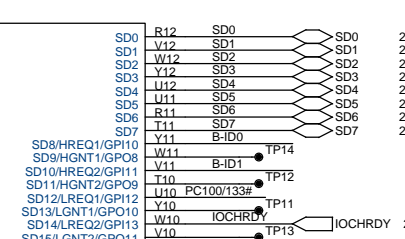

RevA_1224
Modified

Mount: With 1394
NOT-Mount: Without 1394

Dr-Bios.com

PROJECT : ET2S
Quanta Computer Inc.

Size Document Number **VT8231 S-IDE&LAN&RTC** Rev 3C

Date: Thursday, August 29, 2002 Sheet 9 of 25

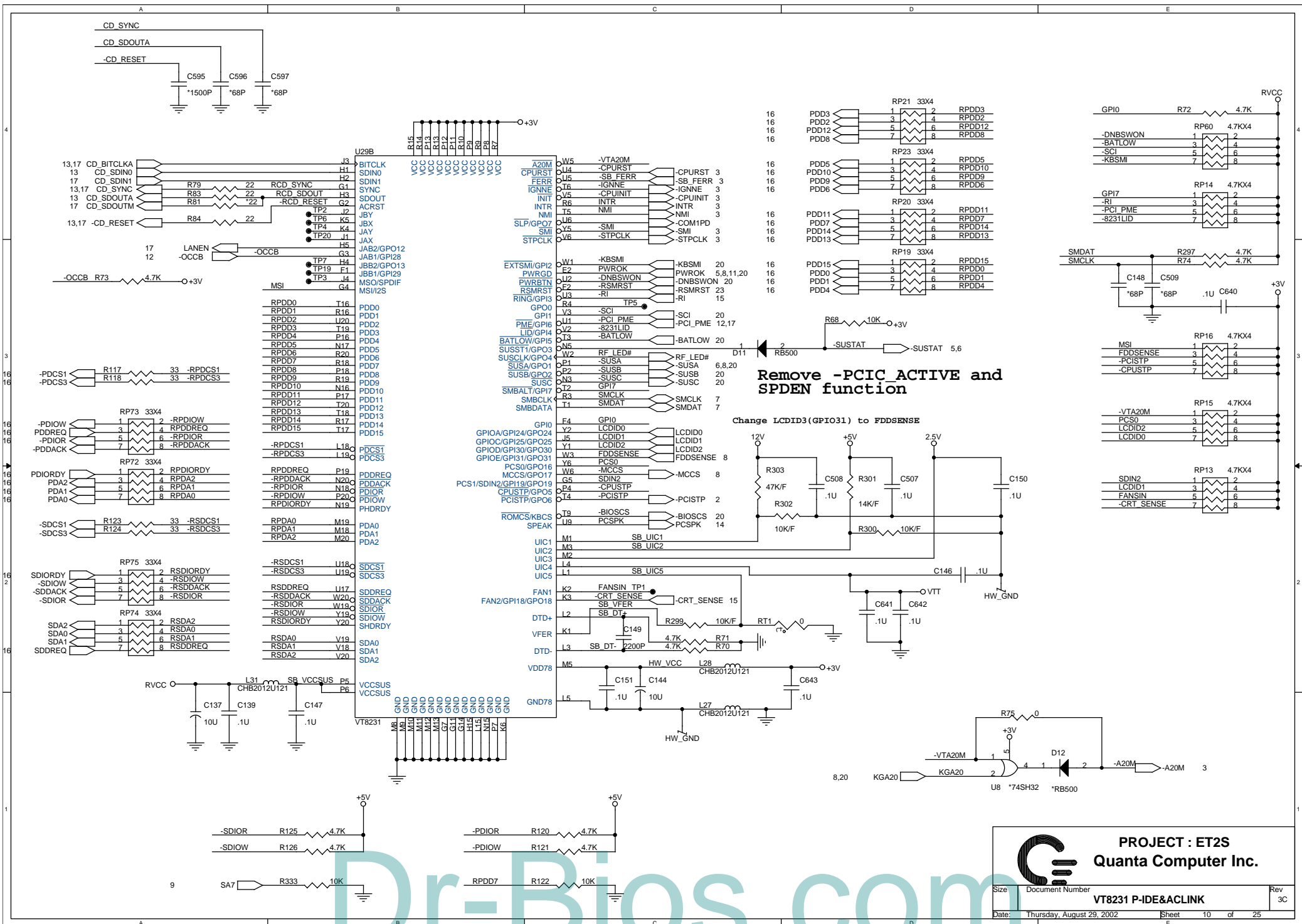

Dr-Bios.com

REV B: 0116

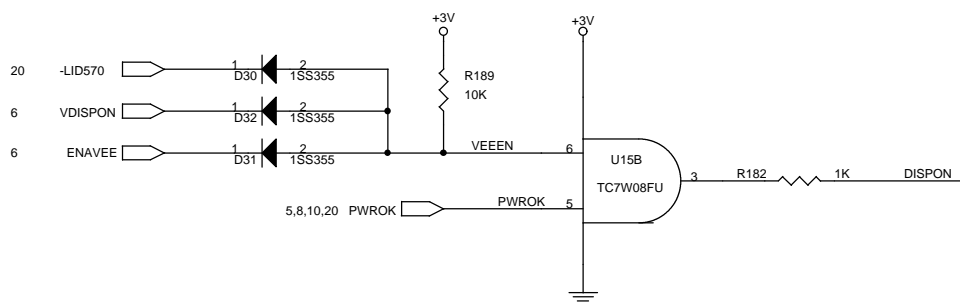
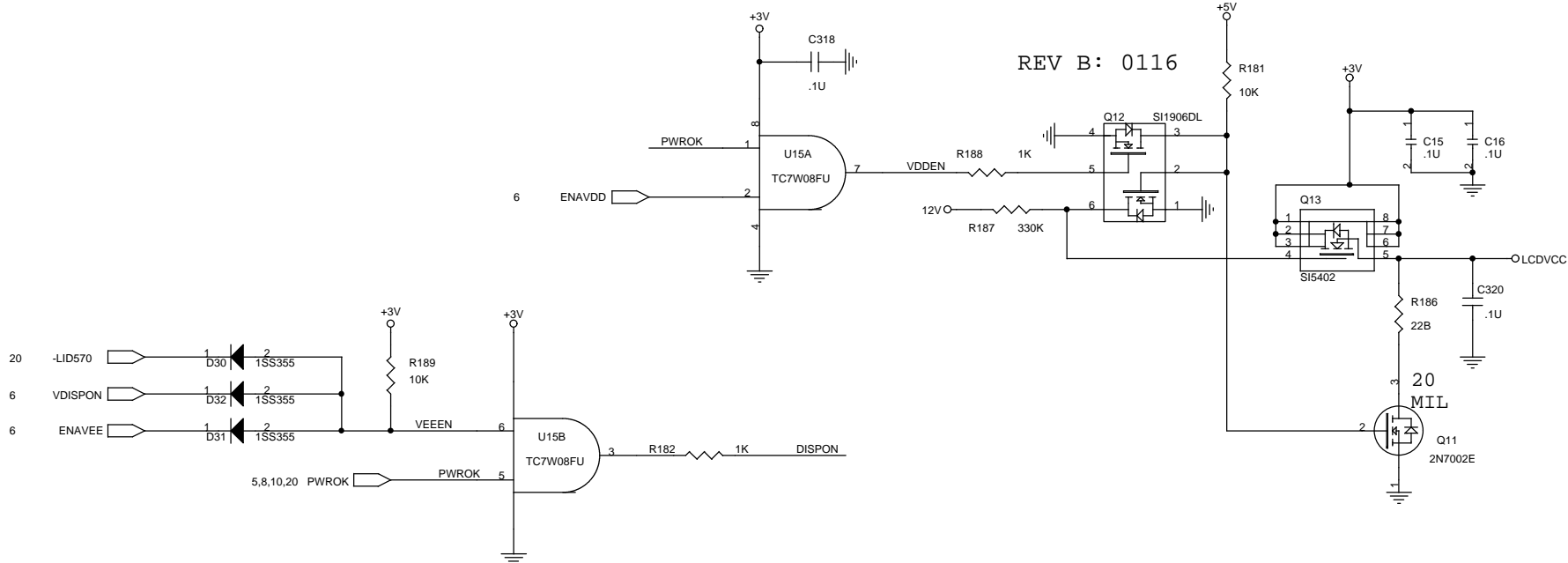

LCDID0	LCDID1	LCDID2	QDI-141X1LH03
1	1	1	
1	0	1	SAM-LTN141X8

Reserve Dual Channels LVDS

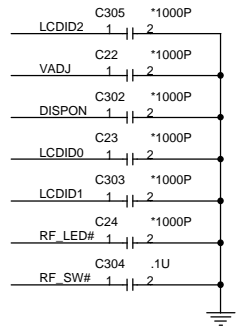
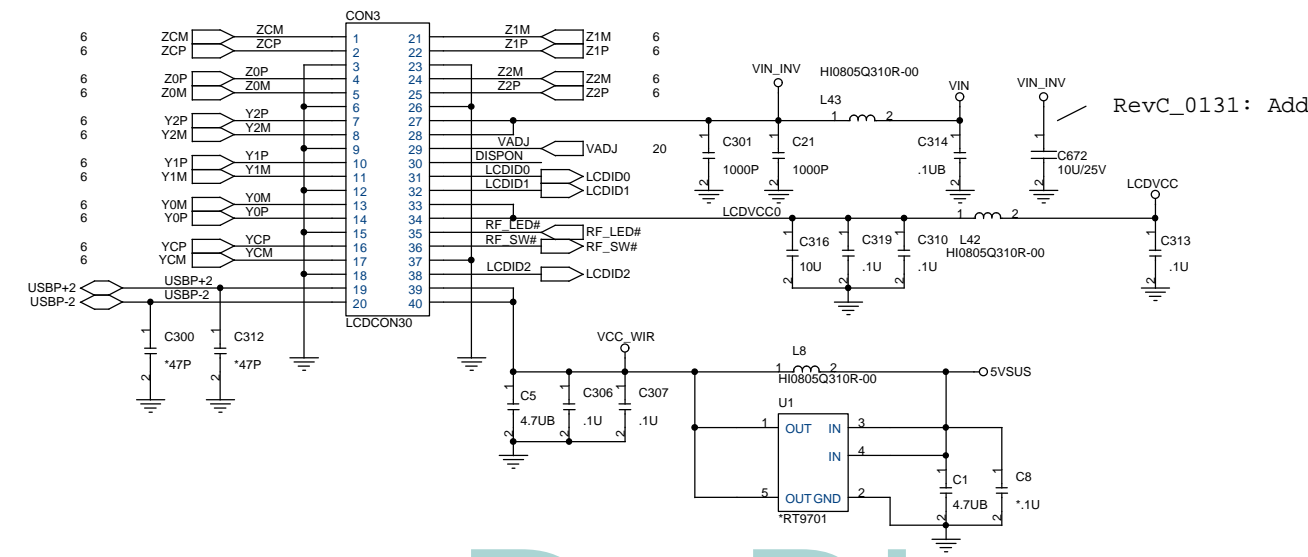

PROJECT : ET2S
Quanta Computer Inc.

Size	Document Number	Rev
		3C
LCD Interface		
Date:	Thursday, August 29, 2002	Sheet 11 of 25

Dr-Bios.com

The AMC20463-002 modem is used for mother board family MBAMC20463-002.

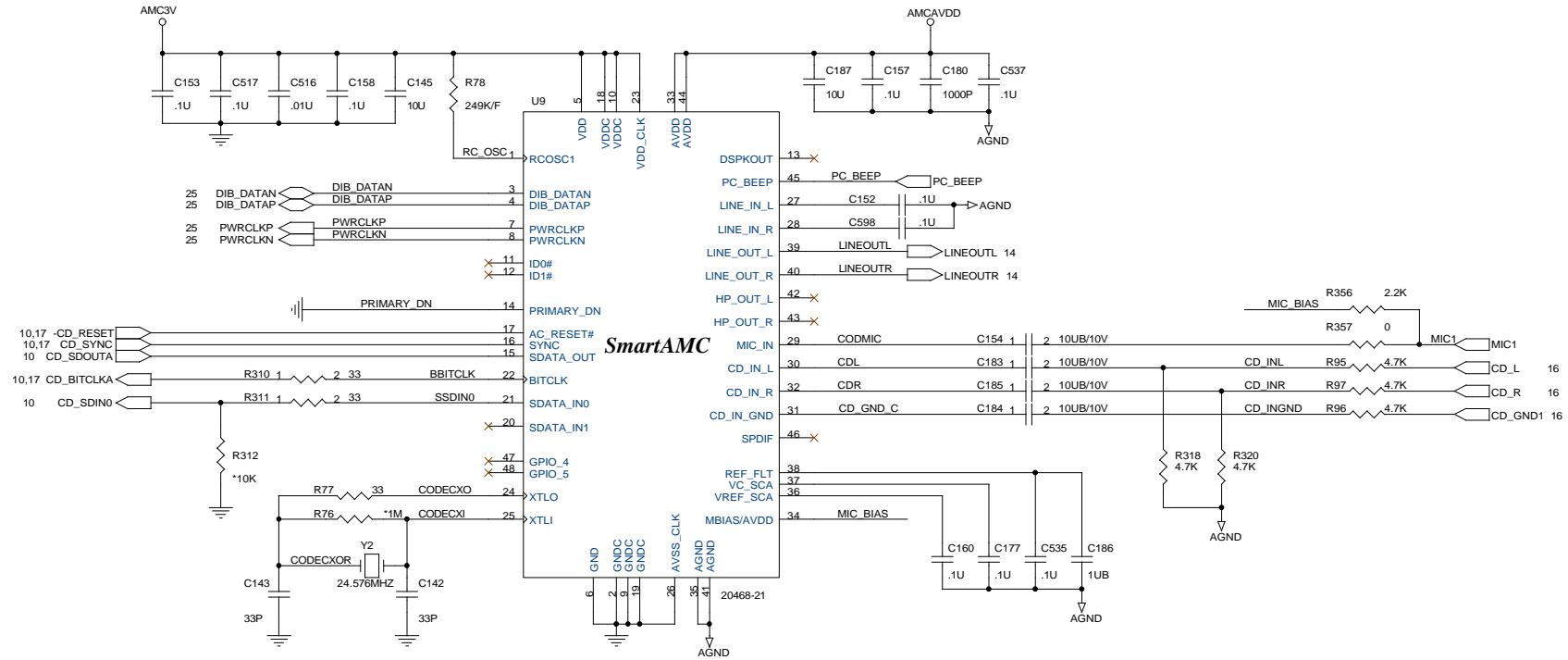

Dr-Bios.com

PROJECT : ET2S
Quanta Computer Inc.

Size Custom	Document Number AC97 CODEC	Rev 3C
Date: Thursday, August 29, 2002	Sheet 13	of 25

GAIN0	GAIN1	SE/BTL#	Av	Zi
0	0	0	-2 V/V	91K Ohm
0	1	0	-6 V/V	45.5K Ohm
1	0	0	-12 V/V	26K Ohm
1	1	0	-24 V/V	14K Ohm
X	X	1	-1 V/V	

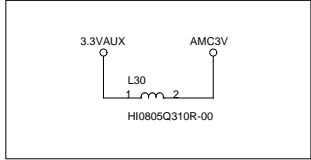

$V_{set} = 1.242V$; $AMCAVDD = 1.242 \times (10 + 16.5) / 10 = 3.29V$

AMCVDD should be 3.3V

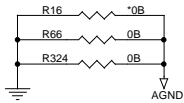
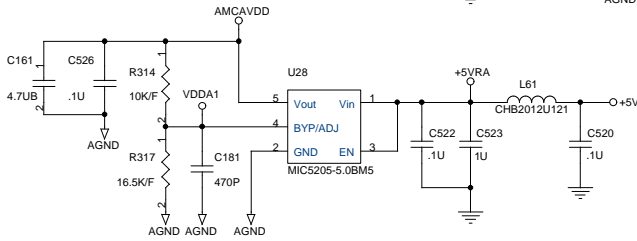

Gain = -6

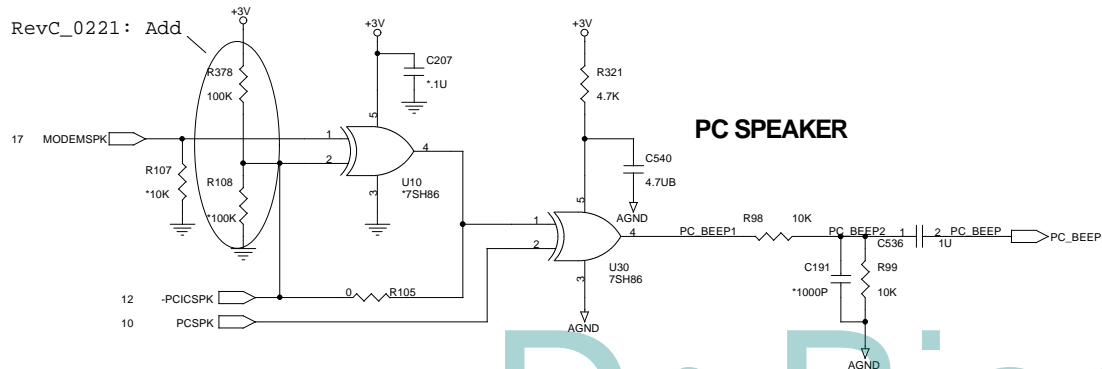

PC SPEAKER

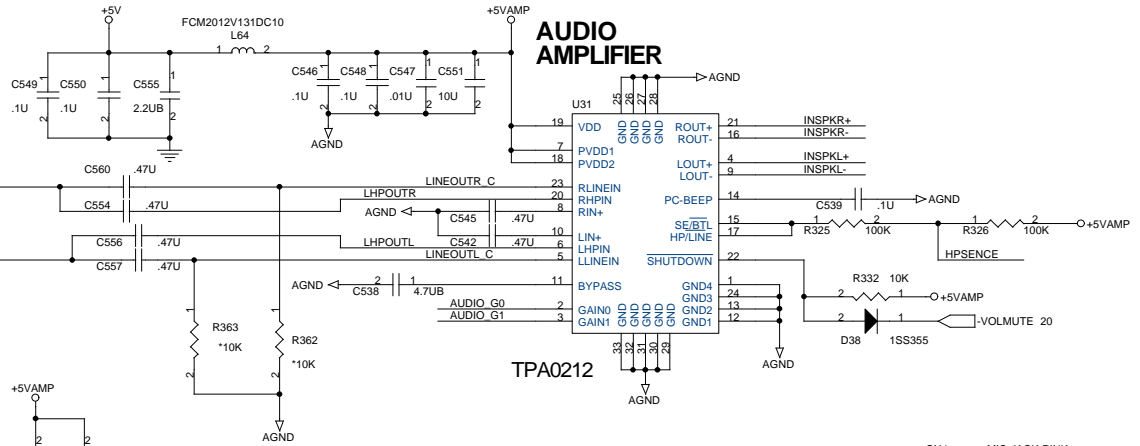

TPA0212

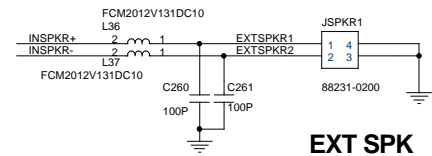
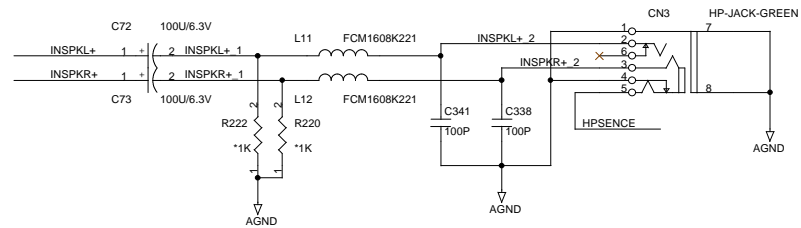
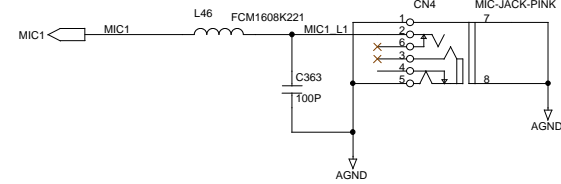

EXT SPK

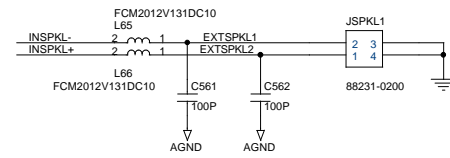

PROJECT : ET2S
Quanta Computer Inc.

Size: Custom | Document Number: TPA0212&Audio Jack | Rev: 3C
 Date: Thursday, August 29, 2002 | Sheet: 14 of 25



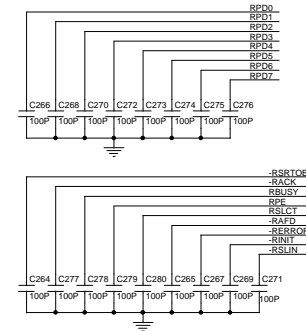
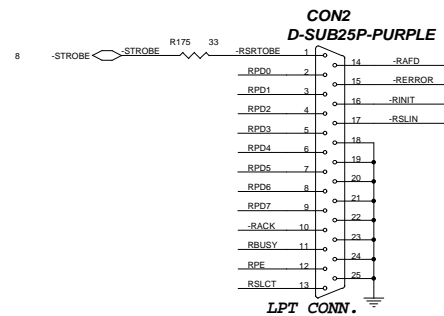
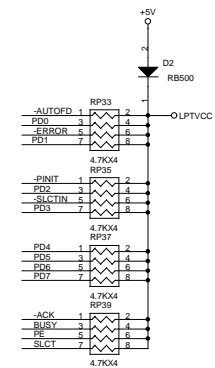
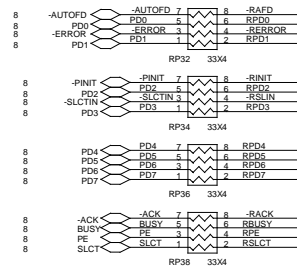
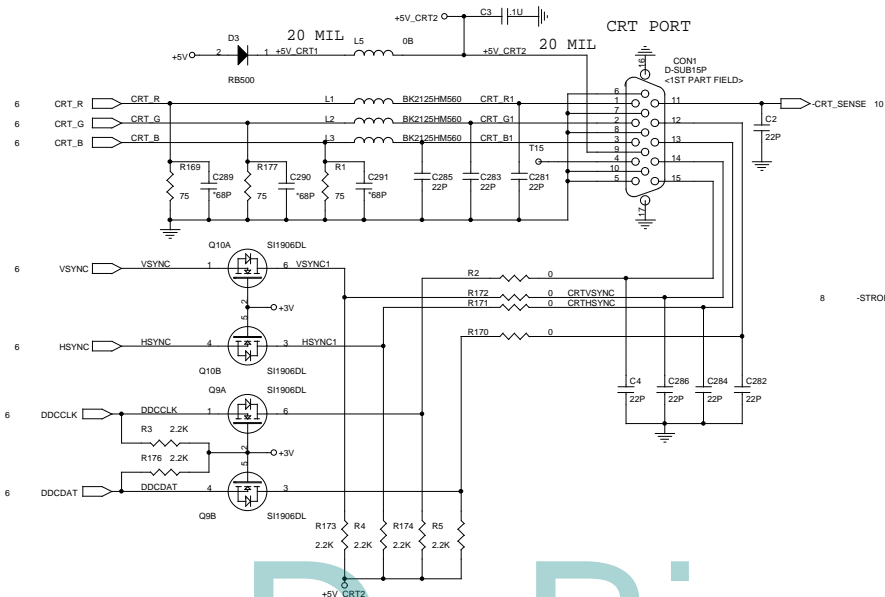
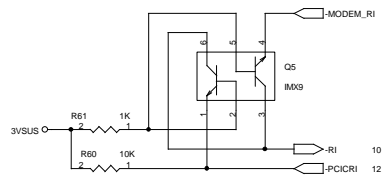
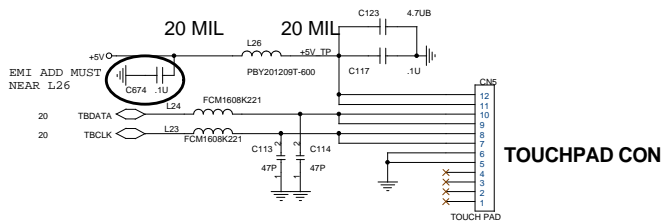
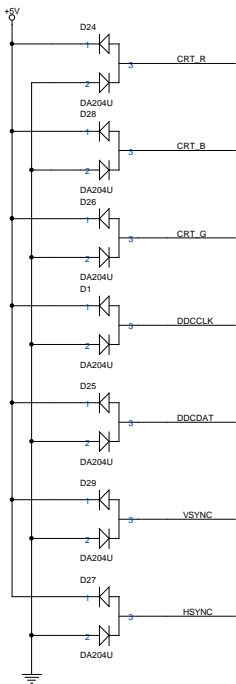

REMOVE COM PORT

Dr-Bios.com

PROJECT : ET2S
 Quanta Computer Inc.

Size: Document Number CRT,TP,LPT,Serial Rev: 3C
 Date: Thursday, August 23, 2002 ESheet 15 of 25

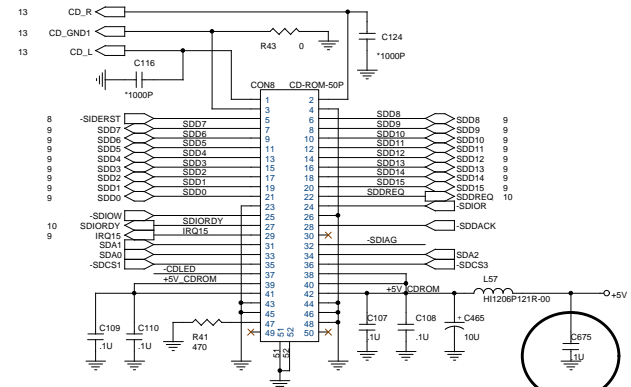

CD-ROM CONNECTOR

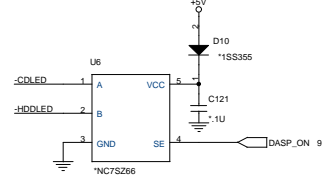

EMI SOLUTION

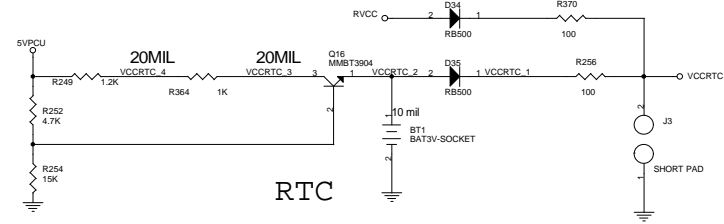

RTC

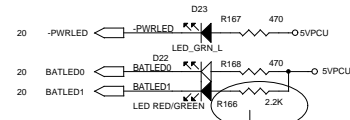
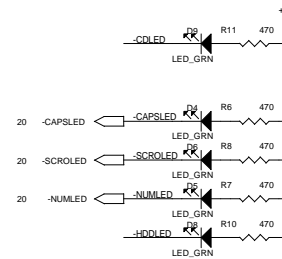
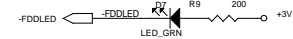
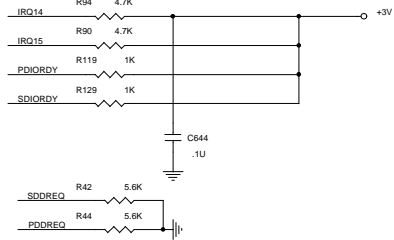

RevC_0209

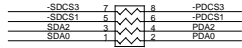
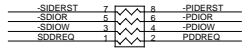

IDE BUS	ONE CHANNEL	TWO CHANNEL
ADD	RP100, RP101, RP102, RP103, RP104, RP105, RP106, R663	RP73, RP74, RP75, RP76, R509, R510, R511, R513, R514, R515, R516, R518, R520, R522, R442, R470
DEL	RP73, RP74, RP75, RP76, R509, R510, R511, R513, R514, R515, R516, R518, R520, R522, R442, R470	RP100, RP101, RP102, RP103, RP104, RP105, RP106, R663

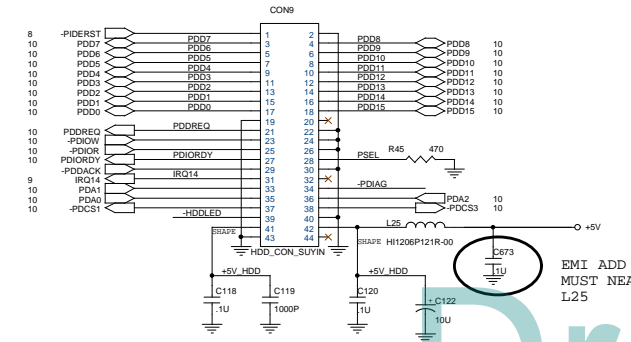

HDD connector

EMI ADD MUST NEAR L25



PROJECT : ET2S
Quanta Computer Inc.

Size | Document Number | IDE,RTC,LEDs | Rev | 3C

Date: Thursday, August 23, 2002 | ESheet | 16 of 25

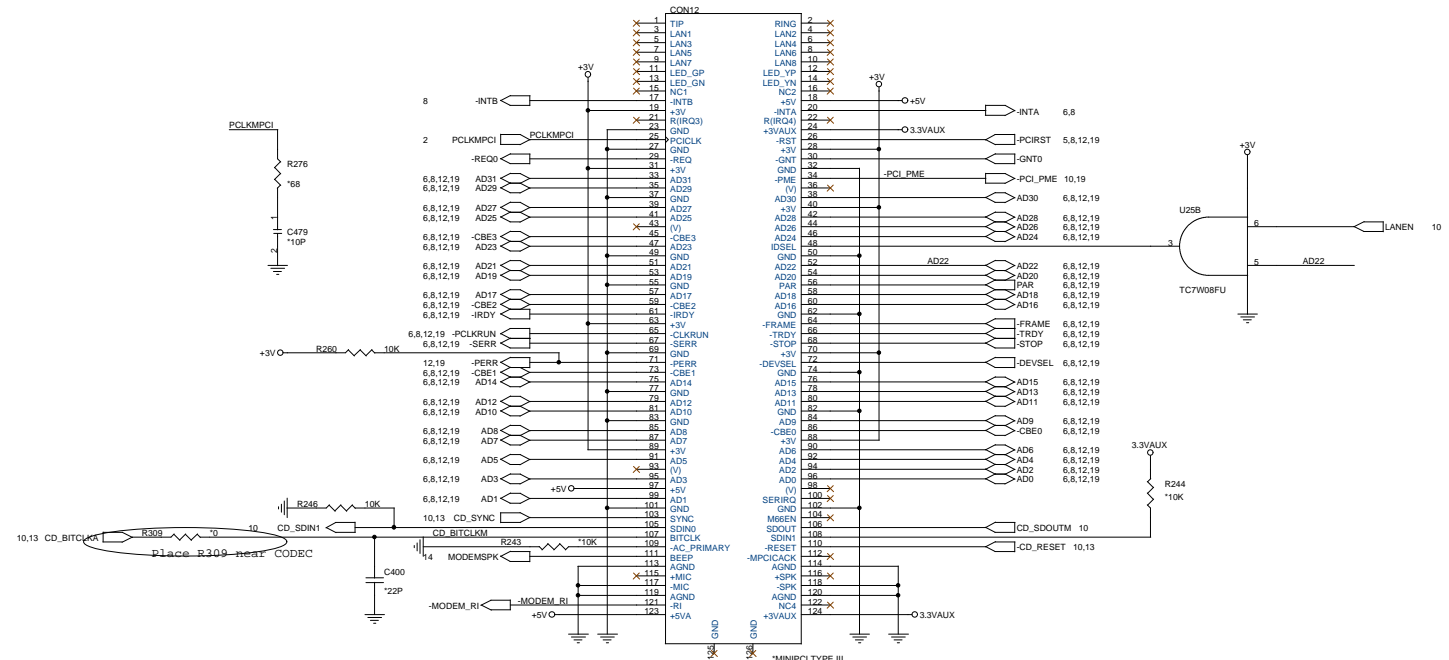
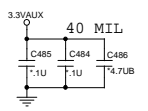
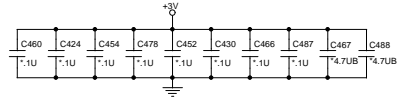
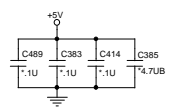

MINI-PCI TYPE III
MINI-PCI Aclink is DATA_IN1

Dr-Bios.com

PROJECT : ET2S
Quanta Computer Inc.

Size	Document Number	MINI-PCI	Rev
			3C
Date	Thursday, August 23, 2002	Sheet	17 of 25

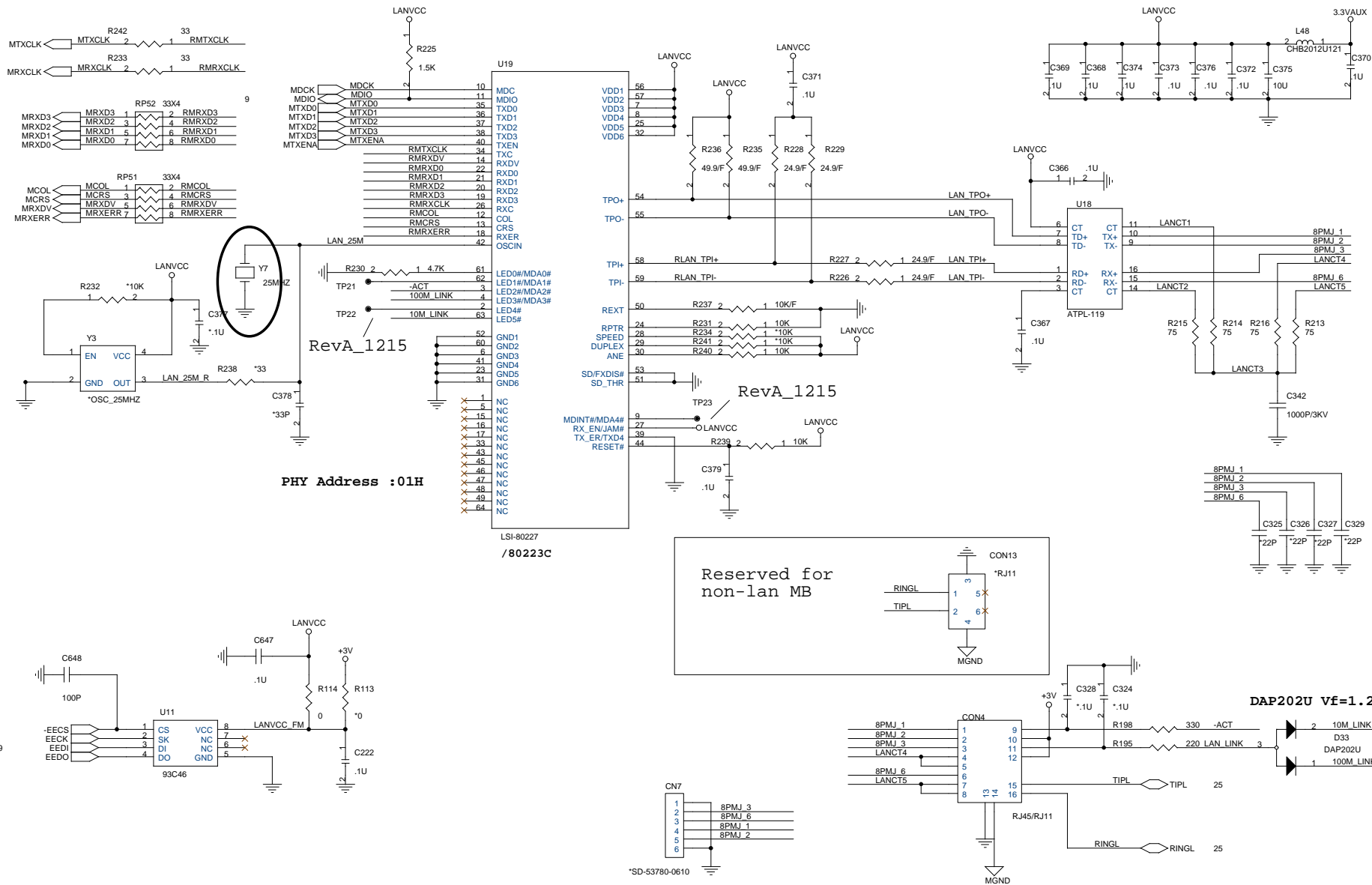

Dr-Bios.com

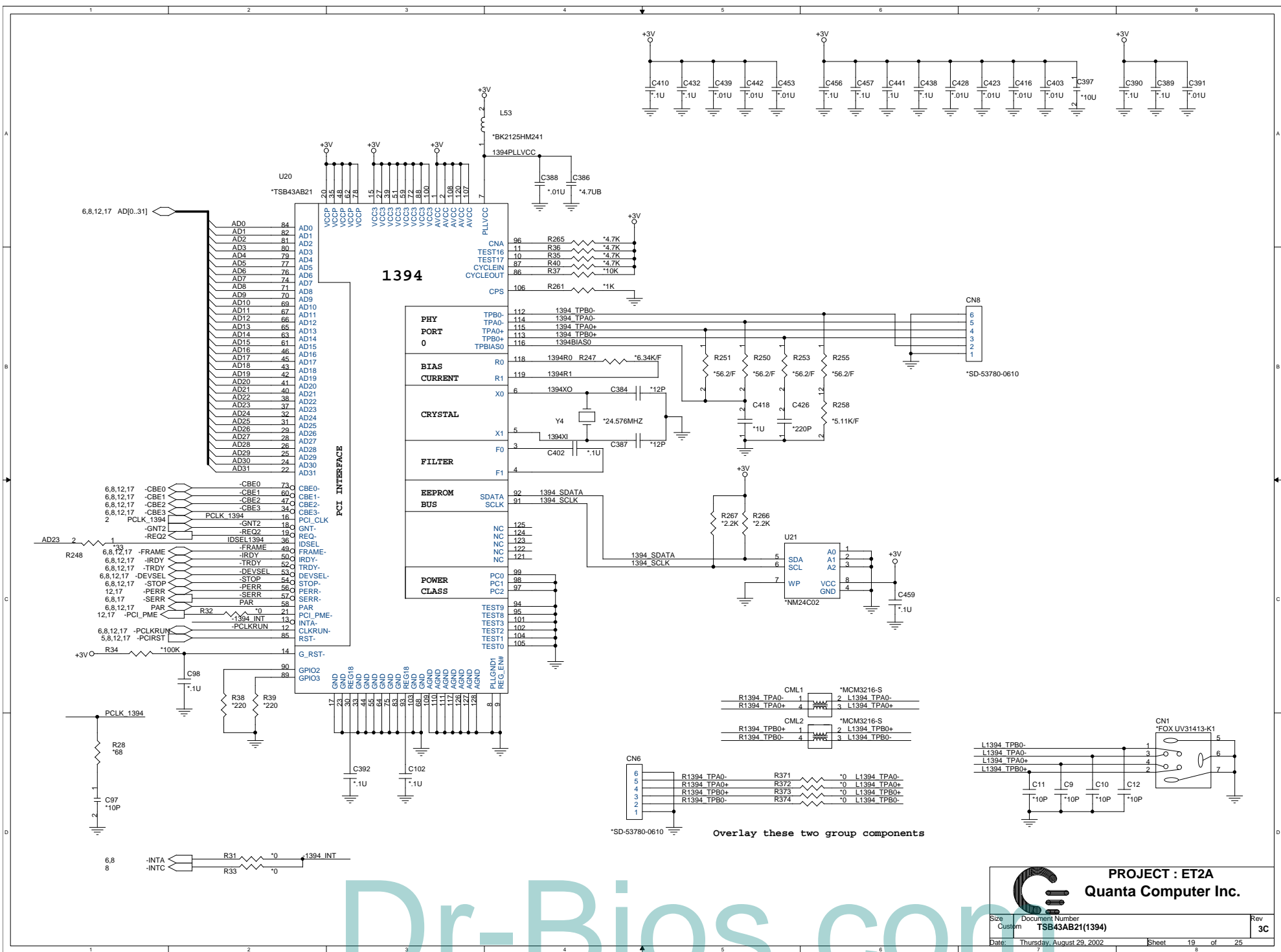

CML1		*MCM3216-S	
R1394	TPA0-	1	2 L1394 TPA0-
R1394	TPA0+	4	3 L1394 TPA0+
CML2		*MCM3216-S	
R1394	TPB0+	1	2 L1394 TPB0+
R1394	TPB0-	4	3 L1394 TPB0-

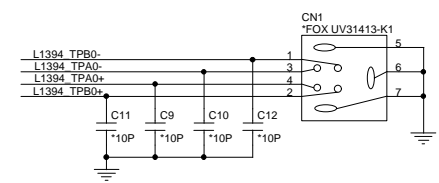
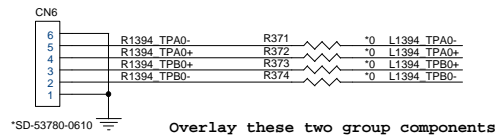

Overlay these two group components

PROJECT : ET2A
Quanta Computer Inc.

Size Custom	Document Number TSB43AB21(1394)	Rev 3C
Date: Thursday, August 29, 2002	Sheet 19	of 25

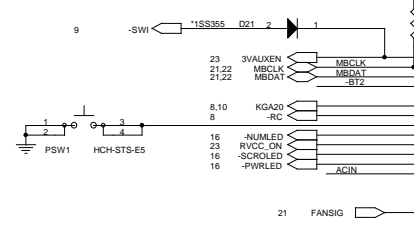
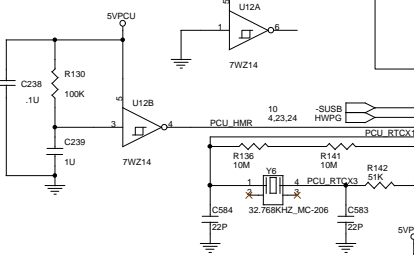
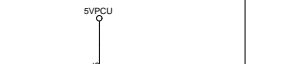
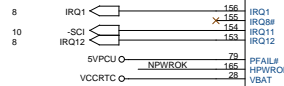
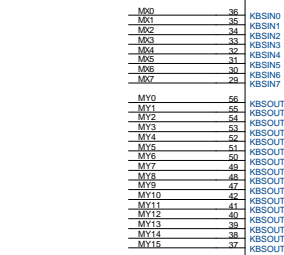
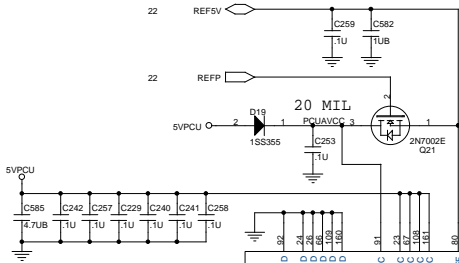
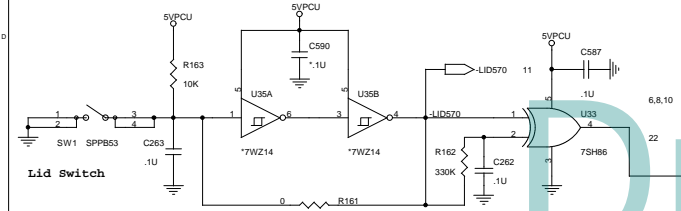
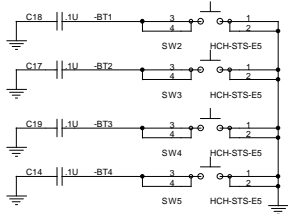
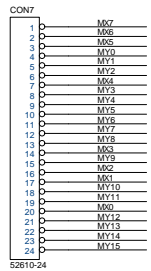
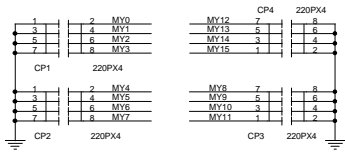
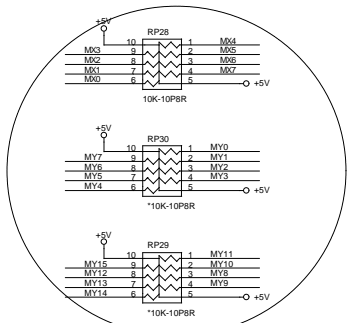

- 1) -NBSWON
- 2) ACTIR
- 3) -SUSV

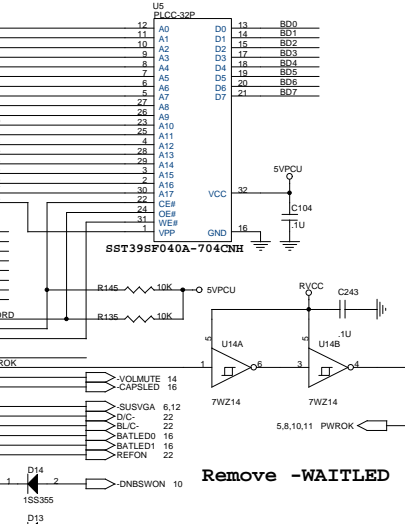
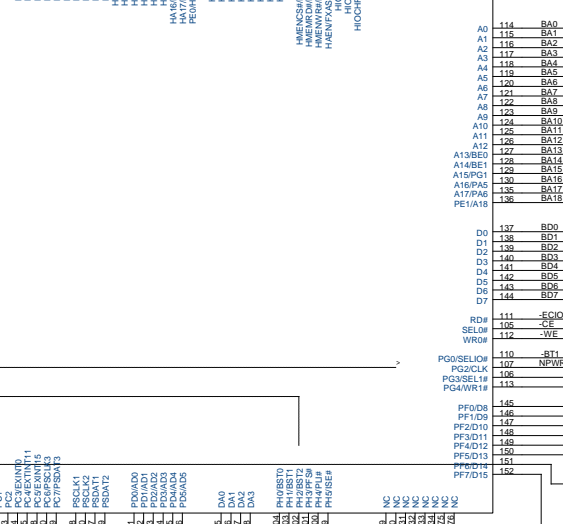
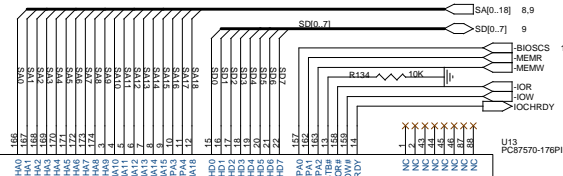

Remove -WAITED

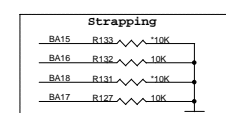

Need to confirm the address

PROJECT : ET2S
Quanta Computer Inc.

Size: _____ Document Number: **PCU NS87570** Rev: **3C**

Date: Thursday, August 23, 2002 ESheet: 20 of 25

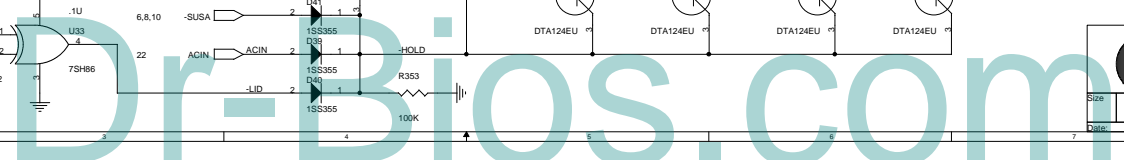

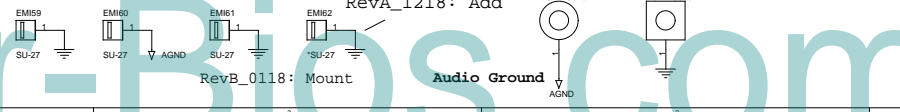
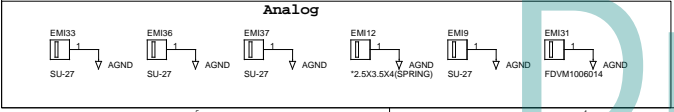
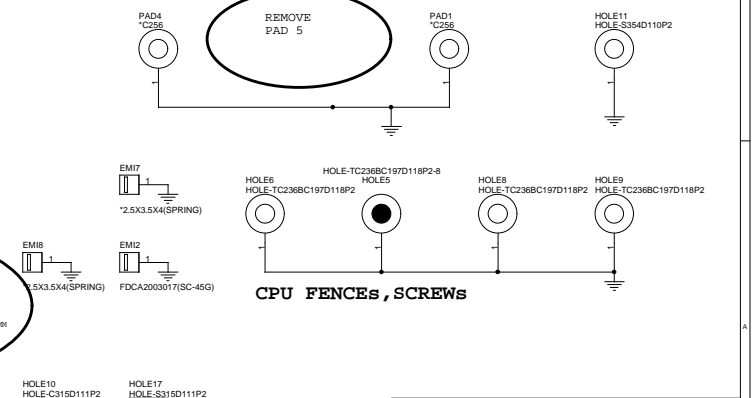
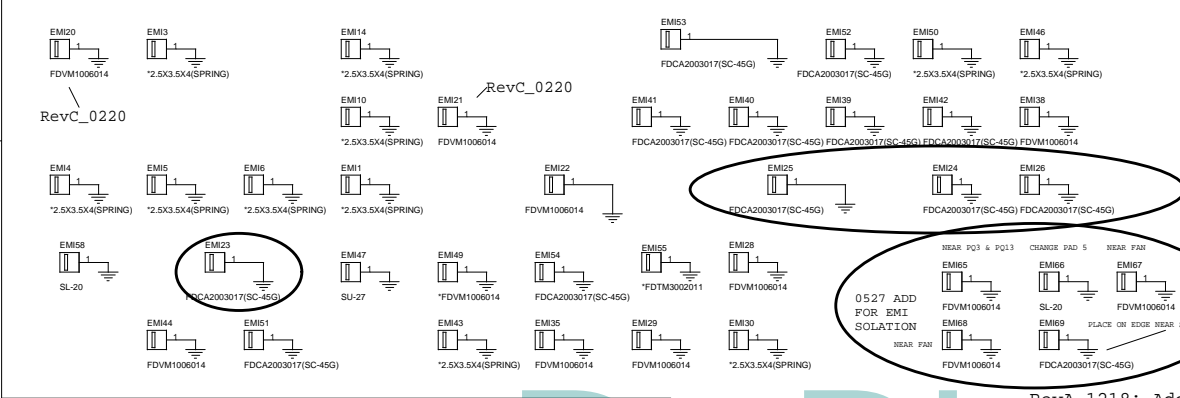
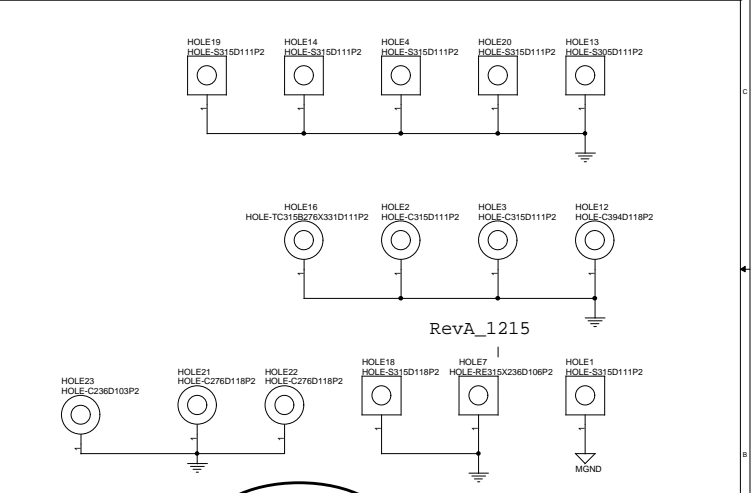
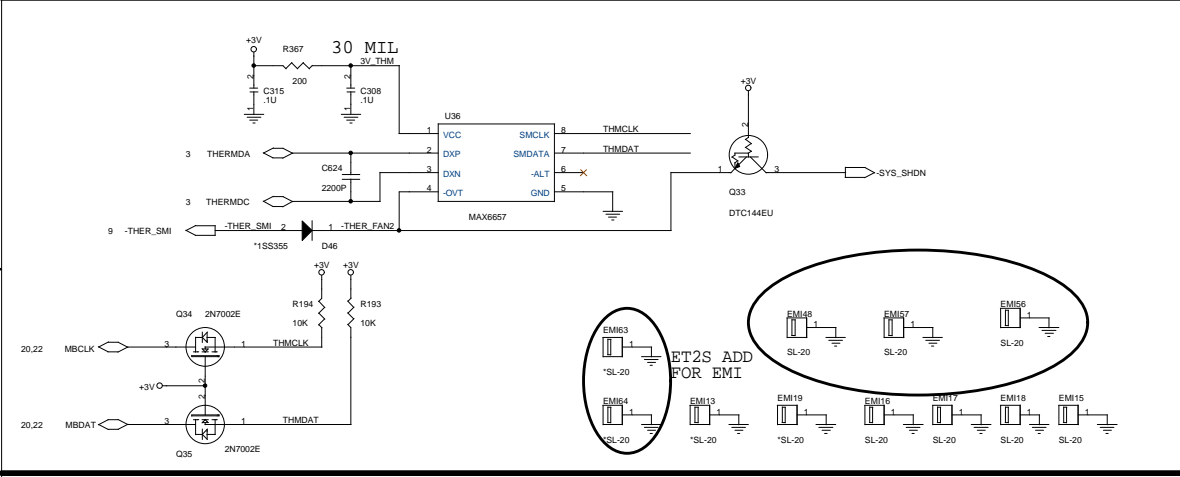
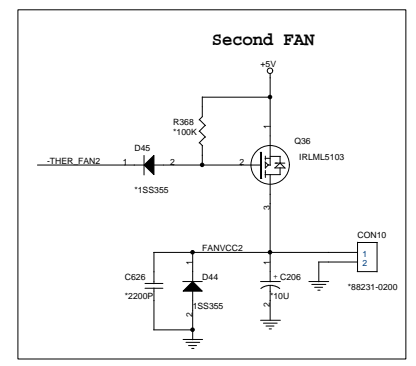
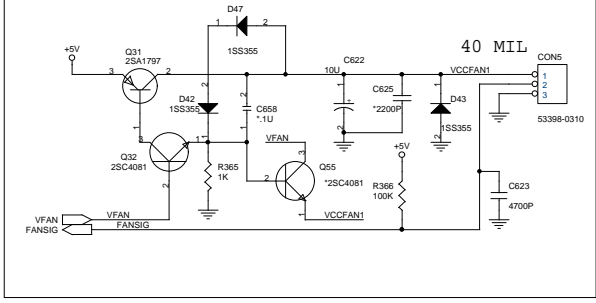
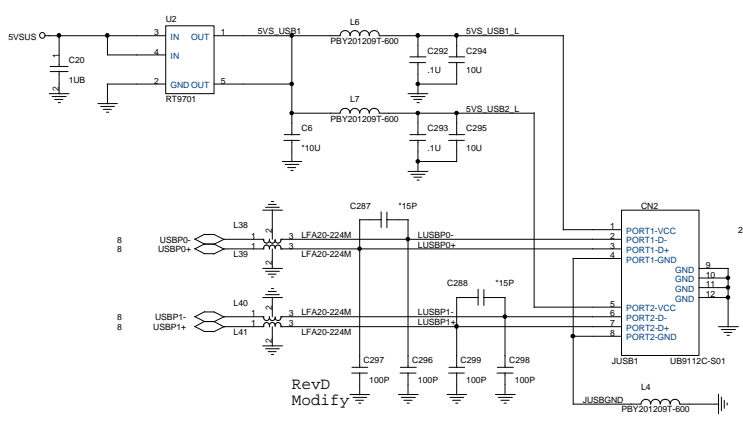

PROJECT : ET2S
Quanta Computer Inc.

Size	Document Number	USB,FANS,Srews&EMI PAD	Rev
Date	Thursday, August 28, 2002	Esheet	21 of 25

RevB_0118: Changed for 75W Ada

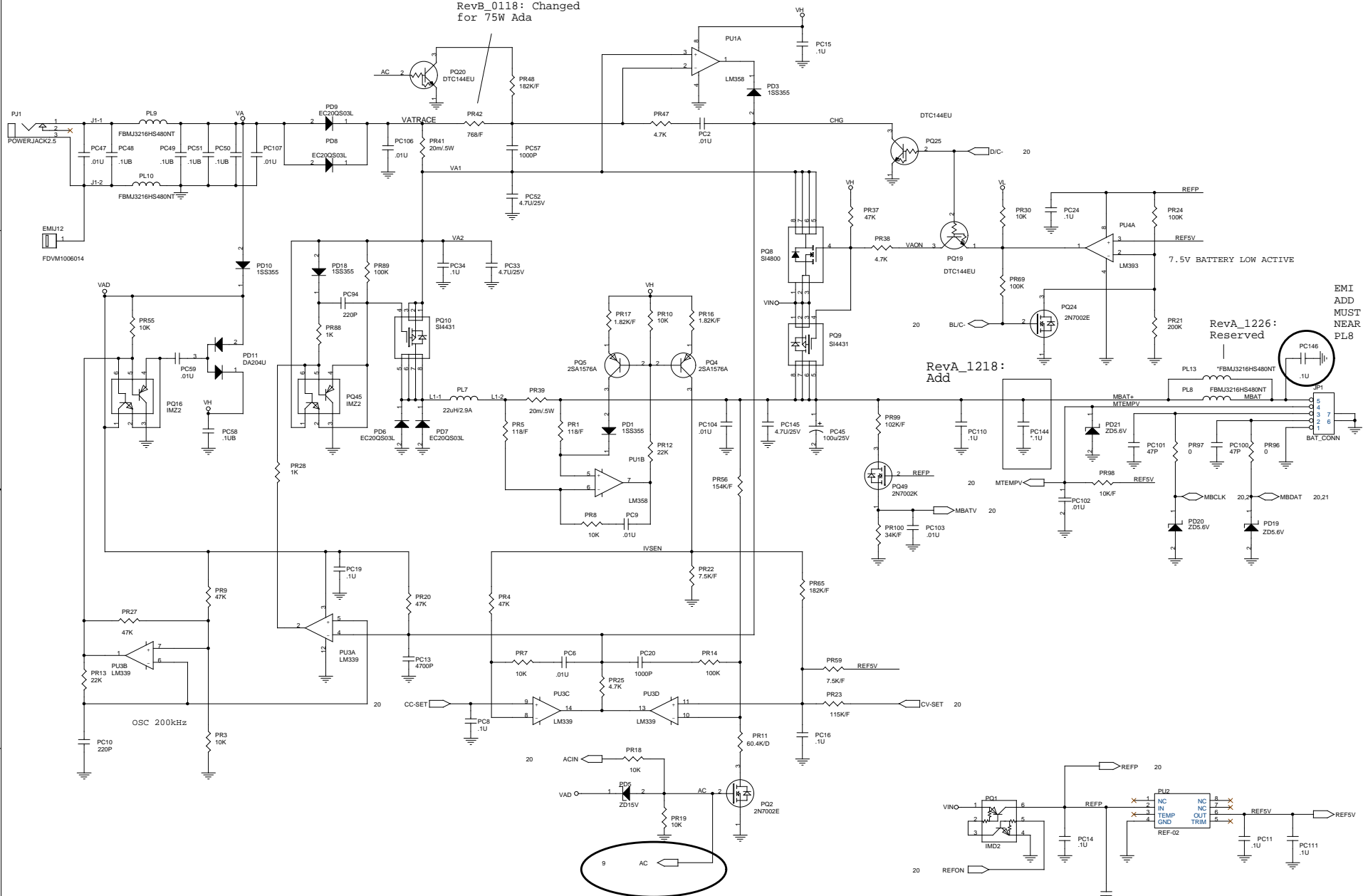

REV D: connect to 8231 for AC detect

RevA_1226: Reserved

RevA_1218: Add

EMI ADD MUST NEAR PL8

PROJECT : ET2S
Quanta Computer Inc.

Size	Document Number	CHARGER CIRCUIT	Rev
			3C
Date	Thursday, August 29, 2002	Sheet	22 of 25

Dr-Bios.com

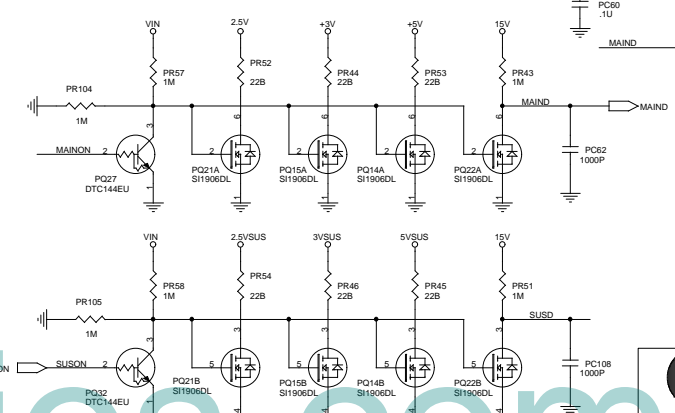
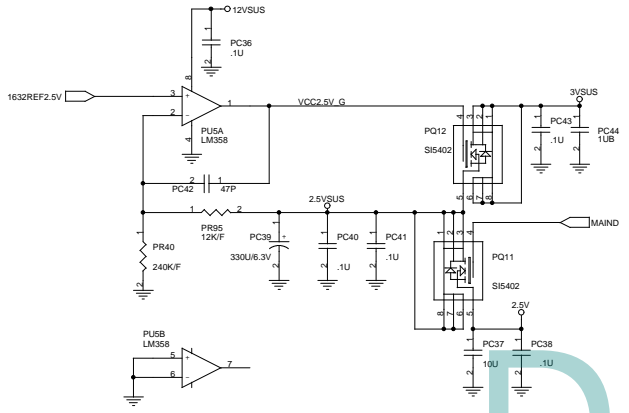
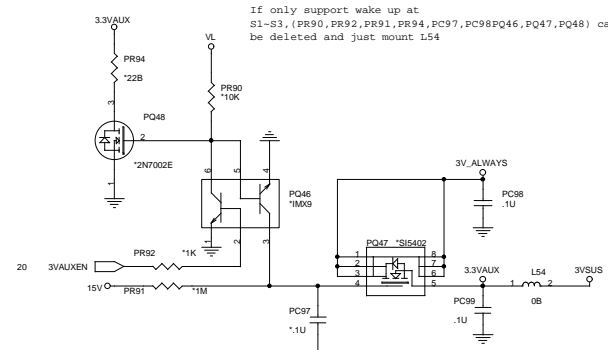
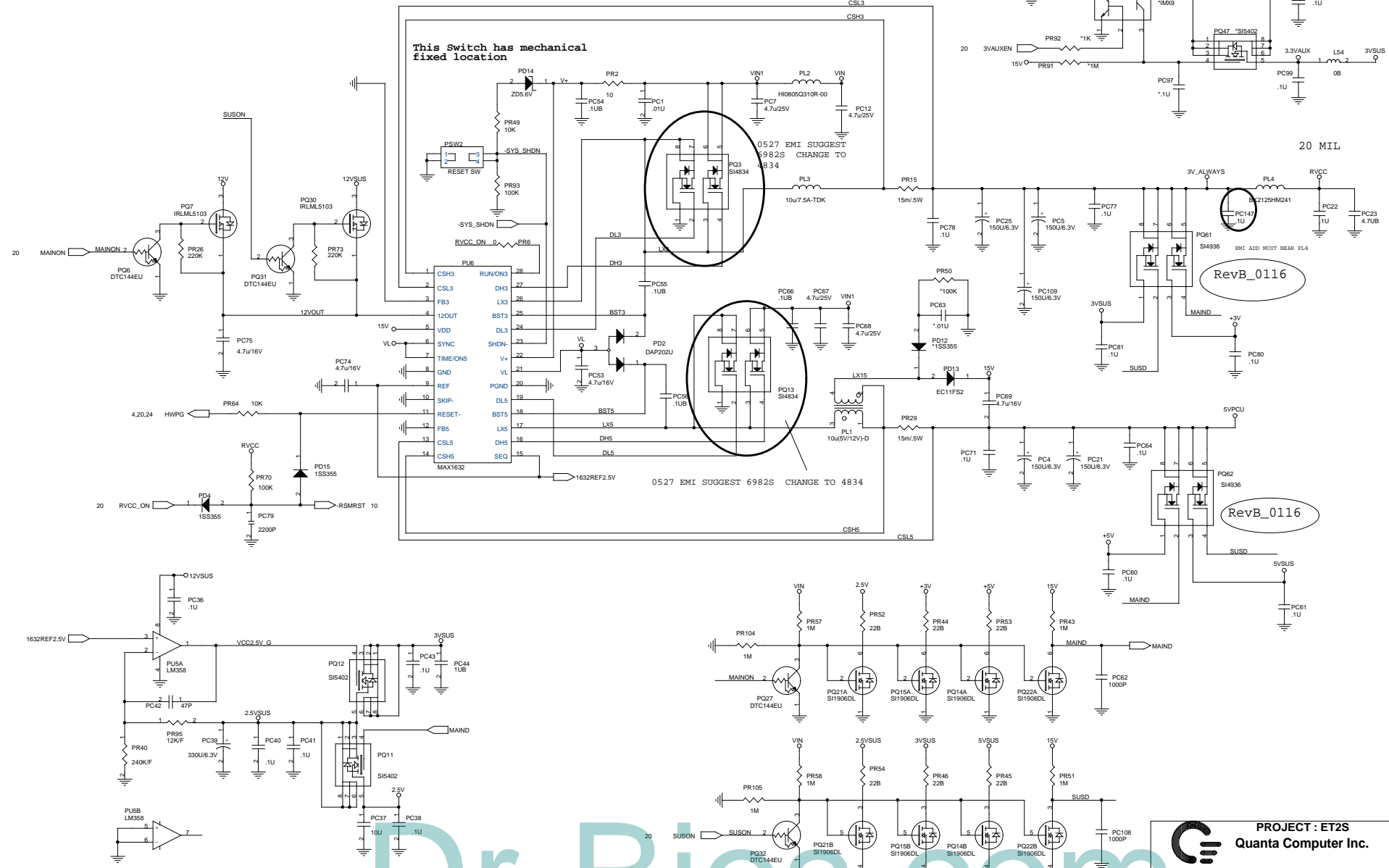
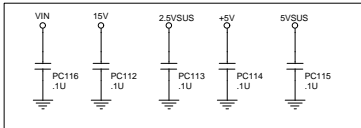

PROJECT : ET2S
Quanta Computer Inc.

Size	Document Number	Rev
	SYS POWER MAX1632	3C
Date	Thursday, August 29, 2002	Sheet 23 of 25

Dr-Bios.com

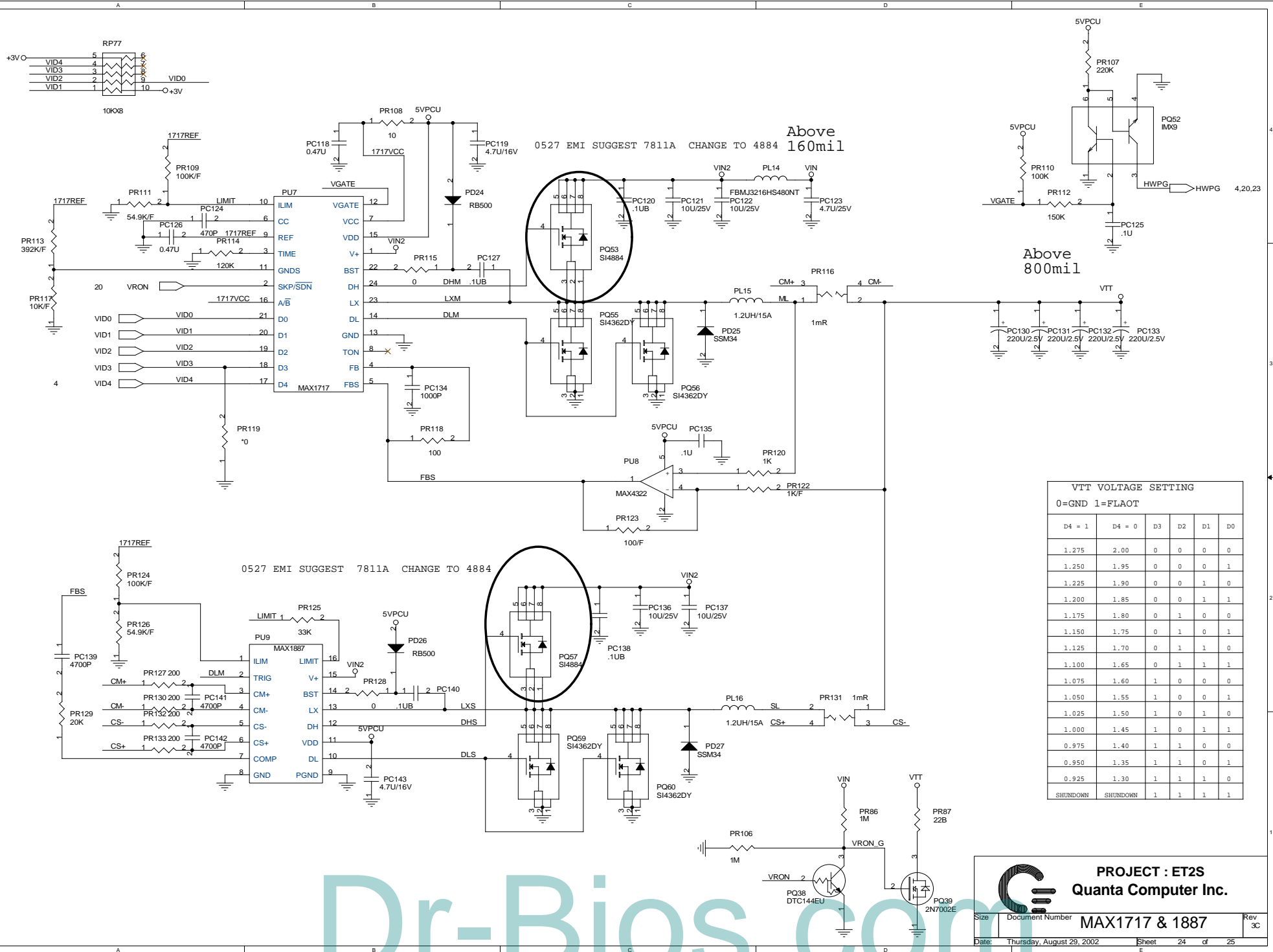

0527 EMI SUGGEST 7811A CHANGE TO 4884
Above 160mil

Above 800mil

VIT VOLTAGE SETTING
0=GND 1=FLAOT

D4 = 1	D4 = 0	D3	D2	D1	D0
1.275	2.00	0	0	0	0
1.250	1.95	0	0	0	1
1.225	1.90	0	0	1	0
1.200	1.85	0	0	1	1
1.175	1.80	0	1	0	0
1.150	1.75	0	1	0	1
1.125	1.70	0	1	1	0
1.100	1.65	0	1	1	1
1.075	1.60	1	0	0	0
1.050	1.55	1	0	0	1
1.025	1.50	1	0	1	0
1.000	1.45	1	0	1	1
0.975	1.40	1	1	0	0
0.950	1.35	1	1	0	1
0.925	1.30	1	1	1	0
SHUTDOWN	SHUTDOWN	1	1	1	1

Dr-Bios.com

PROJECT : ET2S
Quanta Computer Inc.

Size: Document Number **MAX1717 & 1887** Rev: 3C

Date: Thursday, August 29, 2002 Sheet 24 of 25

The AMC20463-002 modem is used for mother board family MBAMC20463-002.

DIGITAL ISOLATION BARRIER

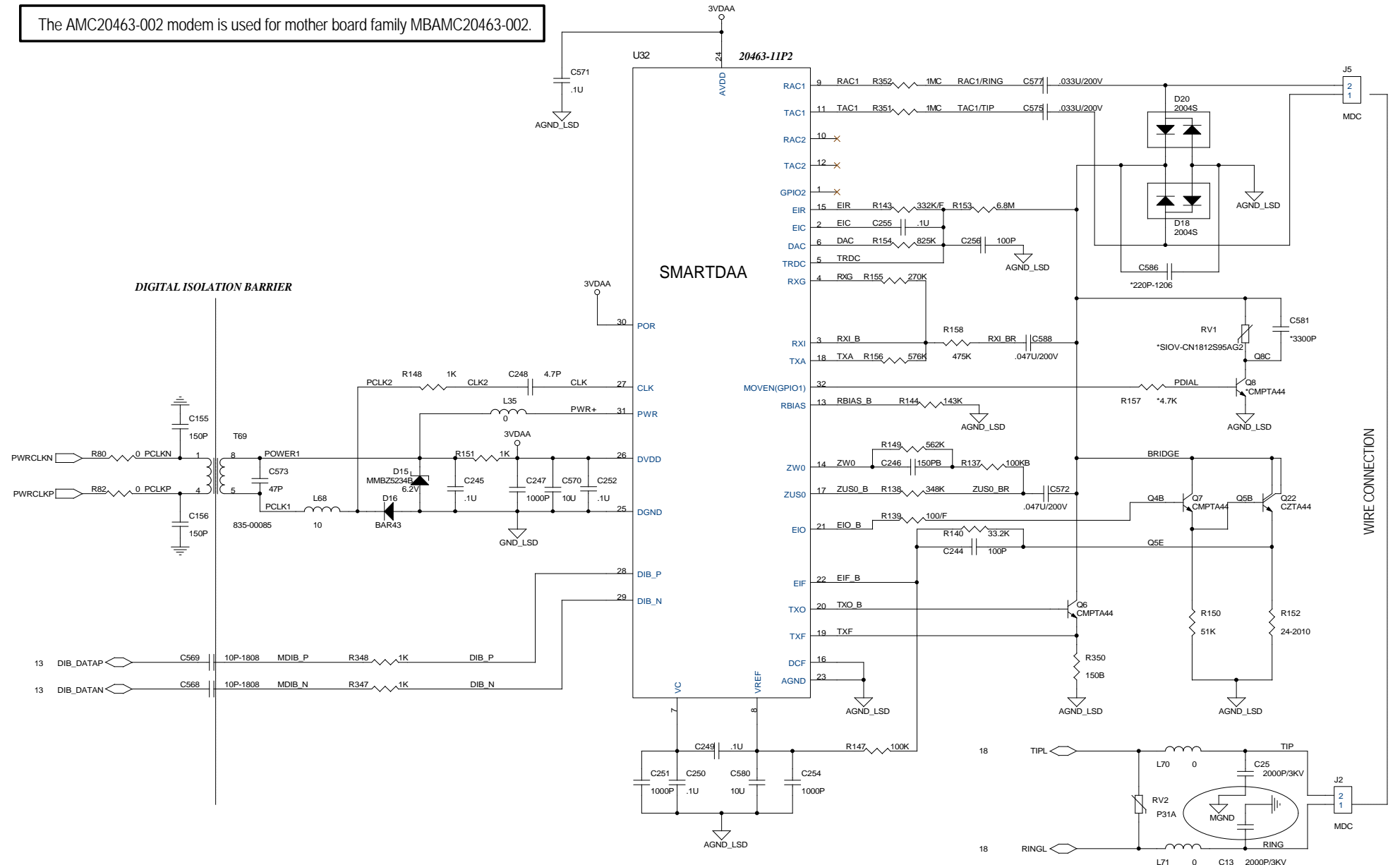

GND_LSD AGND_LSD
With 12 mil to connect both GND

PROJECT : ET2S
Quanta Computer Inc.

Size	Document Number	Rev
	MODEM DAA	3C
Date:	Thursday, August 29, 2002	Sheet 25 of 25

Dr-Bios.com