

8 7 6 5 4 3 2 1  
THIS DRAWING AND SPECIFICATIONS, HEREIN, ARE THE PROPERTY OF INVENTEC CORPORATION AND SHALL NOT BE REPRODUCED, COPIED, OR USED IN WHOLE OR IN PART AS THE BASIS FOR THE MANUFACTURE OR SALE OF ITEMS WITHOUT WRITTEN PERMISSION, INVENTEC CORPORATION, 2009 ALL RIGHT RESERVED.

F HSF Property: ROHS or Halogen-Free(5L3?)

# ALADDIN

## DB BUILD

2011.07.11

DATE	CHANGE NO.	REV
21-OCT-2002		

DRAWER	EE	DATE	POWER	DATE	INVENTEC			
DESIGN					TITLE MODEL PROJECT FUNCTION			
CHECK					PROJECT NAME			
RESPONSIBLE								
SIZE			VER		SIZE	CODE	DOC NUMBER	REV
FILE NAME					5	CS	1310XXXXX-0-0	X01
P/N			XXX			SHEET		of 27

# TABLE OF CONTENTS

1. PROJECT NAME	29. DDR3_DIMM0(A)	56. EXPRESS CARD
2. TABLE OF CONTENTS	30. DDR3_DIMM1(A)	57. RF SOLUTION
3. BLOCK DIAGRAM	31. DDR3_DIMM0(B)	58. LCM CNTR
4. SYSTEM POWER(CHARGER)	32. DDR3_DIMM1(B)	59. CRT
5. SYSTEM POWER(BATT SELECTOR)	33. ESATA ON DOCK	60. DOCKING CNTR
6. SYSTEM POWER(P3V3A&P5V0A)	34. PANTER POINT_1 (HDA,JTAG,SPI,SATA)	61. MXM CNTR
7. SYSTEM POWER(DDR P1V5)	35. PANTER POINT_2 (PCI-E,SMBUS,CLK)	62. PEG CAPS
8.SYSTEM POWER(P1V05_LAN_M)	36. PANTER POINT_3 (DMI,FDI,GPIO)	63. AUDIO
9. SYSTEM POWER(P1V0S_VCCP)	37. PANTER POINT_4 (LVDS,DDI)	64. AUDIO
10. SYSTEM POWER(P1V8S)	38. PANTER POINT_5 (PCI,USB,NVRAM)	65. AUDIO
11. SYSTEM POWER(PVSA)	39. PANTER POINT_6 (GPIO,VSS_NCFT,RSVD)	66. AUDIO DB CNTR & USB CHARGER PORT
12. SYSTEM POWER(PVCORE1)	40. PANTER POINT_7 (POWER)	67. USB3 DB CNTR
13. SYSTEM POWER(PVCORE2)	41. PANTER POINT_8 (POWER)	68. LEDS IN USB3 DB
14. HP_OCP	42. PANTER POINT_9 (GND)	69. DISPLAY PORT
15. SYSTEM POWER(PORT FOR P3V3A&P5V0A)	43. KBC & SPI	70. USB & ESATA COMBO
16. POWER PADS	44. KEYBOARD	71. USB3 CNTR
17. ENABLE TIMING DELAY	45. SUPER I/O	72. CARD READER
18. ADP SIGNALES	46. KB BL & STICK POINT & TOUCH PAD	73. SD/MMC & 1394
19. POWER(SLEEP)	47. HDD & ODD CNTR	74. POWER SW & HALL SENSOR DB
20. POWER(SEQUENCE)	48. BT & FP & CAMERA	75. APPLICATION DB
21.FAN & THERMAL	49. ACCELEROMETER	76. SCREW
22.XDP CONN	50. TPM & MDC	
23. IVY BRIDGE_1 (CLK,MISC,JTAG)	51. LAN PHY	
24. IVY BRIDGE_2 (POWER)	52. LAN SWITCH RJ45	
25. IVY BRIDGE_3 (DMI,DP,PEG,FDI)	53. WLAN & WWAN & SIM CARD	
26. IVY BRIDGE_4 (DDR3)	54. MSATA MINI CARD	
27. IVY BRIDGE_5 (GRAPHICS POWER)	55. SMART CARD	
28. IVY BRIDGE_6 (GND,RESERVED)		

<b>INVENTEC</b>			
TITLE MODEL,PROJECT,FUNCTION TABLE OF CONTENTS			
SIZE A3	CODE CS	DOC.NUMBER 1310xxxxx-0-0	REV X01
SHEET 2 of 95			

# ALADDIN Block Diagram

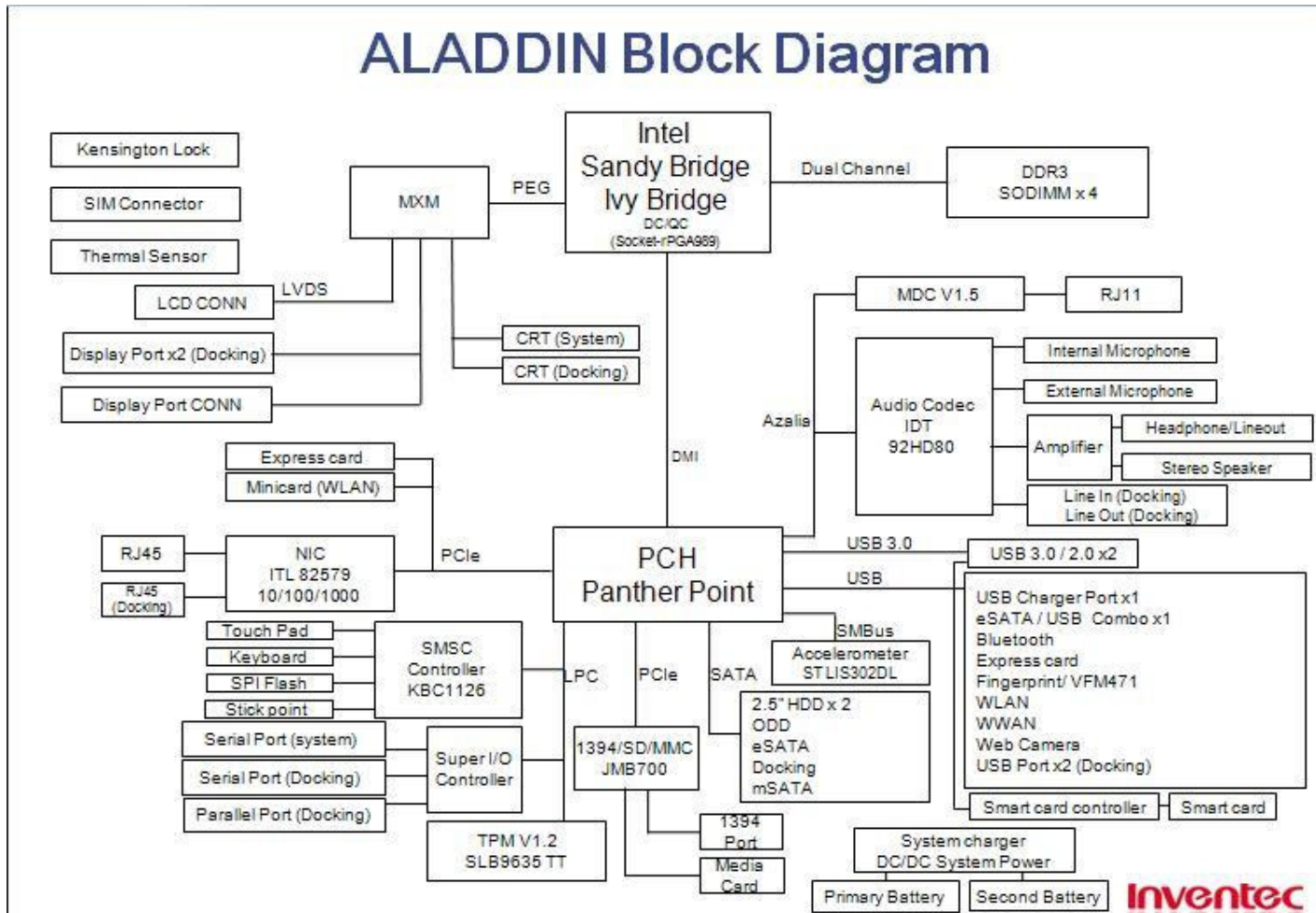

**INVENTEC**

TITLE			
BLOCK DIAGRAM			
MODEL, PROJECT, FUNCTION			
SIZE	CODE	DOC NUMBER	REV
A3	CS	1310xxxxx-0-0	X01

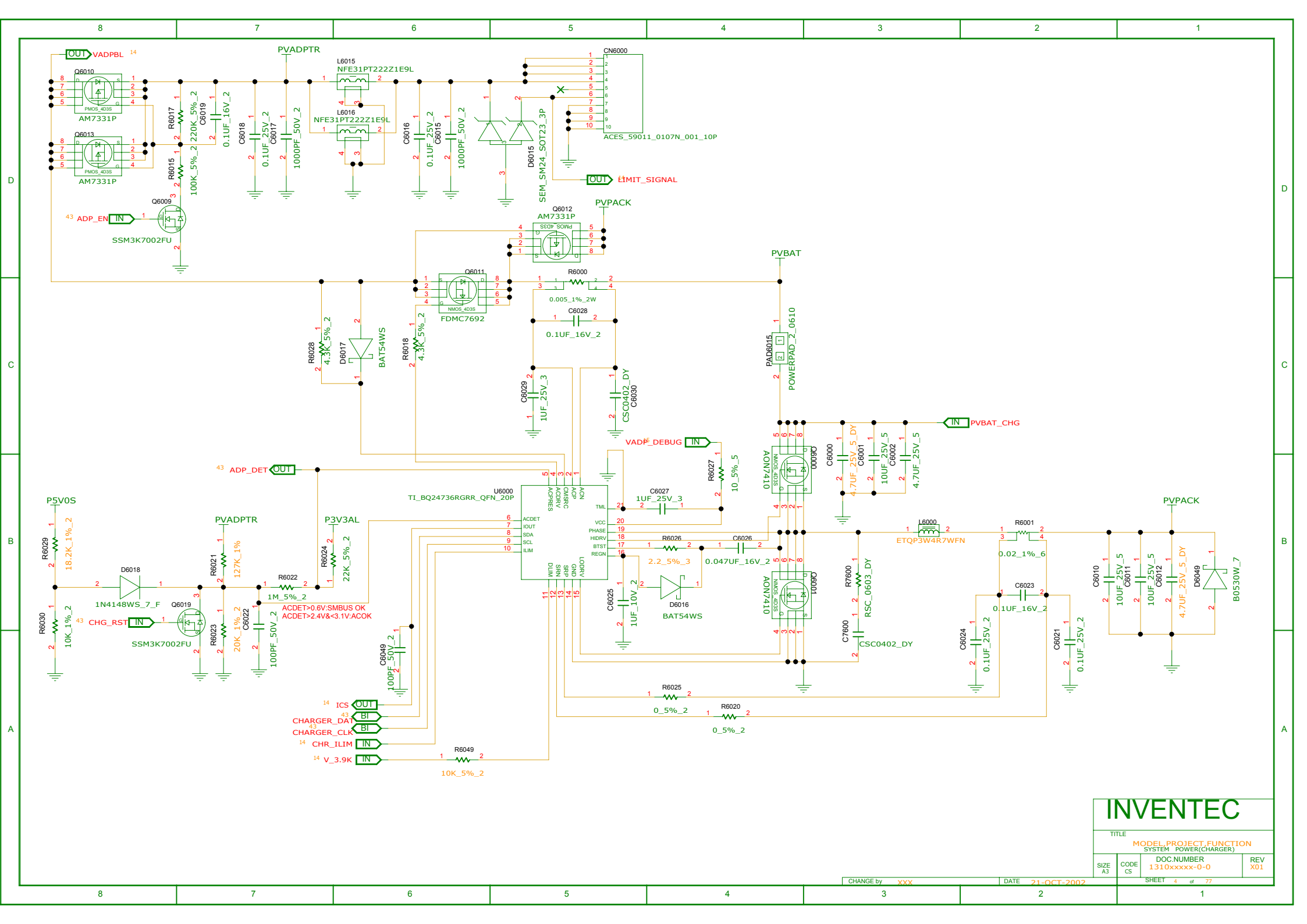

<b>INVENTEC</b>			
TITLE			
MODEL PROJECT FUNCTION			
SYSTEM POWER(CHARGER)			
SIZE A3		CODE CS	
DOC NUMBER		REV X01	
1310xxxxx-0-0		1310xxxxx-0-0	
SHEET 4 of 77			

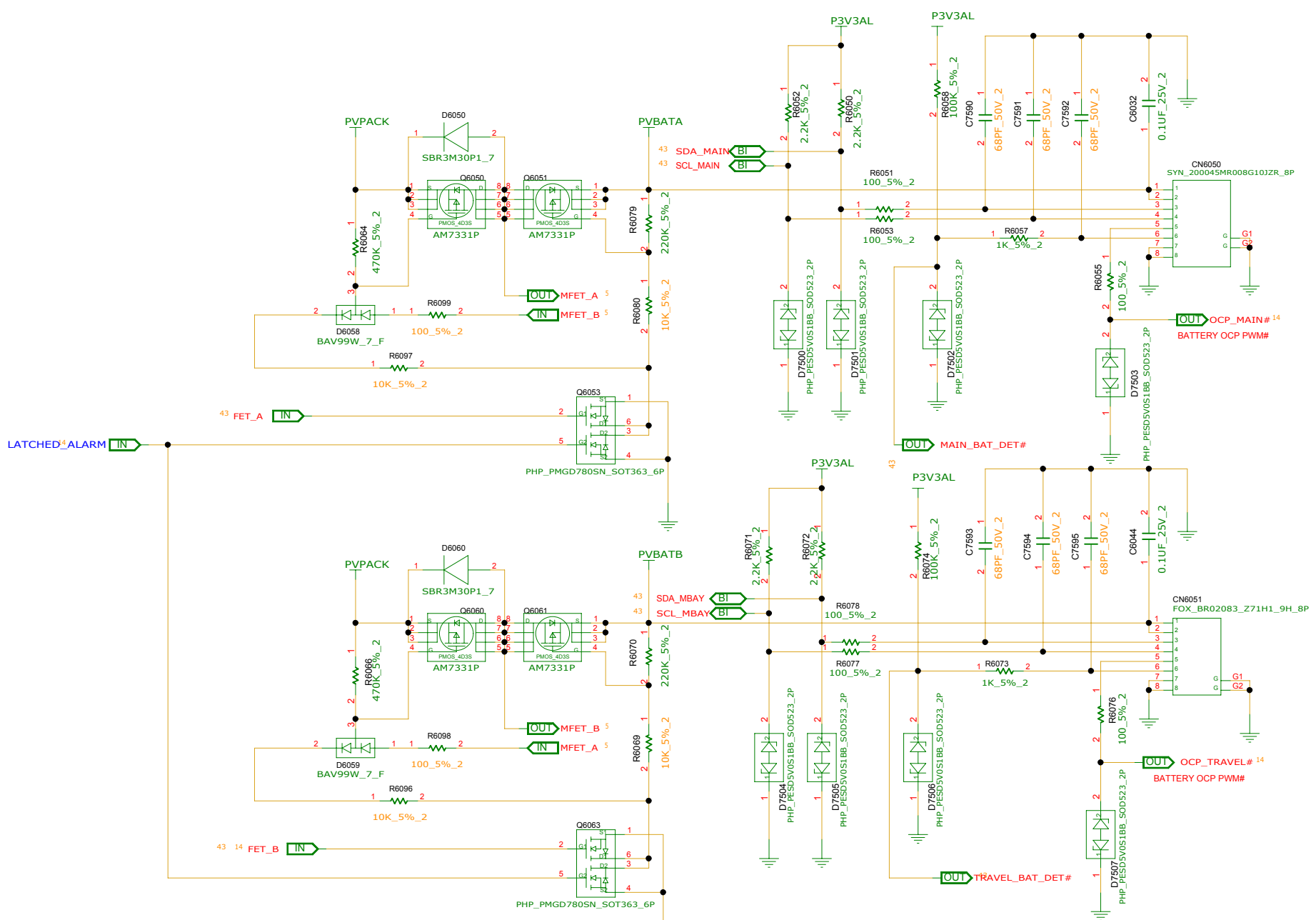

**INVENTEC**

TITLE			
MODEL PROJECT FUNCTION SYSTEM POWER(BATT_SELECTOR)			
SIZE A3	CODE CS	DOC NUMBER 1310xxxxx-0-0	REV X01
CHANGE by XXX		DATE 21-OCT-2002	
SHEET 5 of 77			

8 7 6 5 4 3 2 1

8 7 6 5 4 3 2 1

D

D

C

C

B

B

A

A

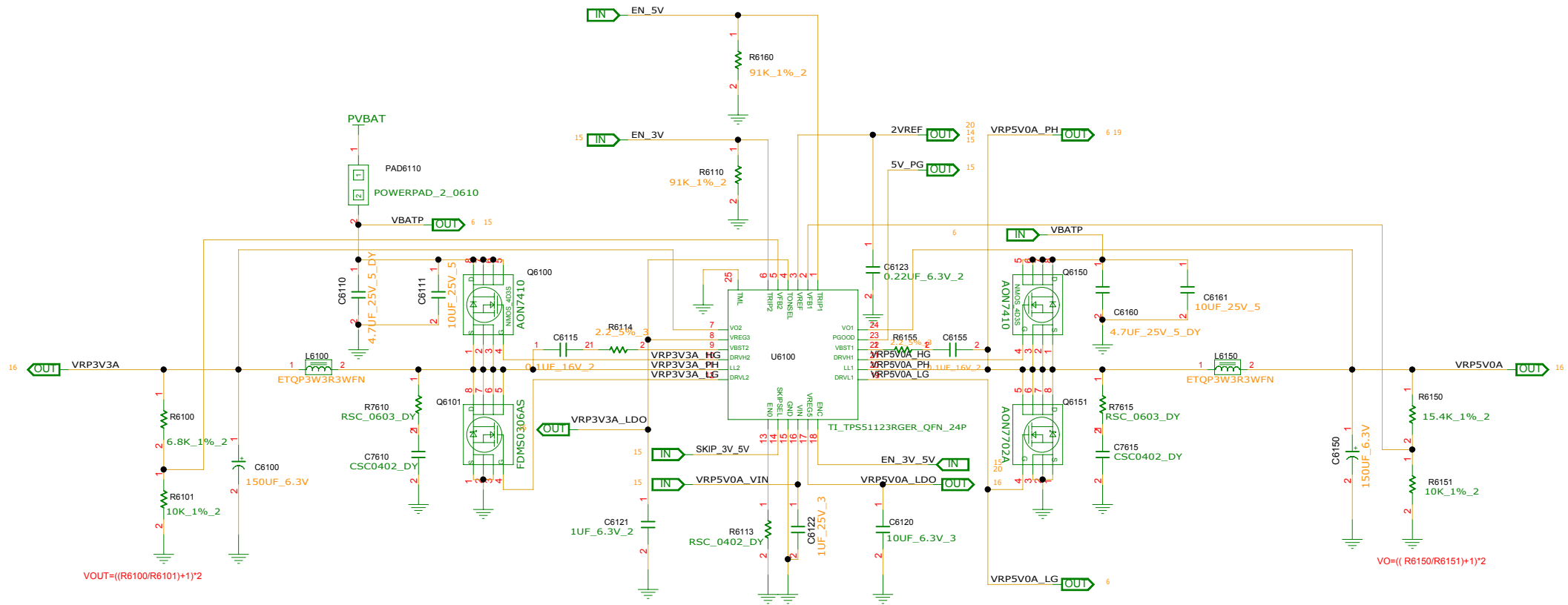

$$V_{OUT} = ((R6100/R6101)+1)*2$$

**INVENTEC**

TITLE			
MODEL,PROJECT,FUNCTION Block Diagram			
SIZE A3	CODE CS	DWG NUMBER 1310xxxxx-0-0	REV X01
CHANGE by XXX		DATE 21-OCT-2002	SHEET 6 of 77

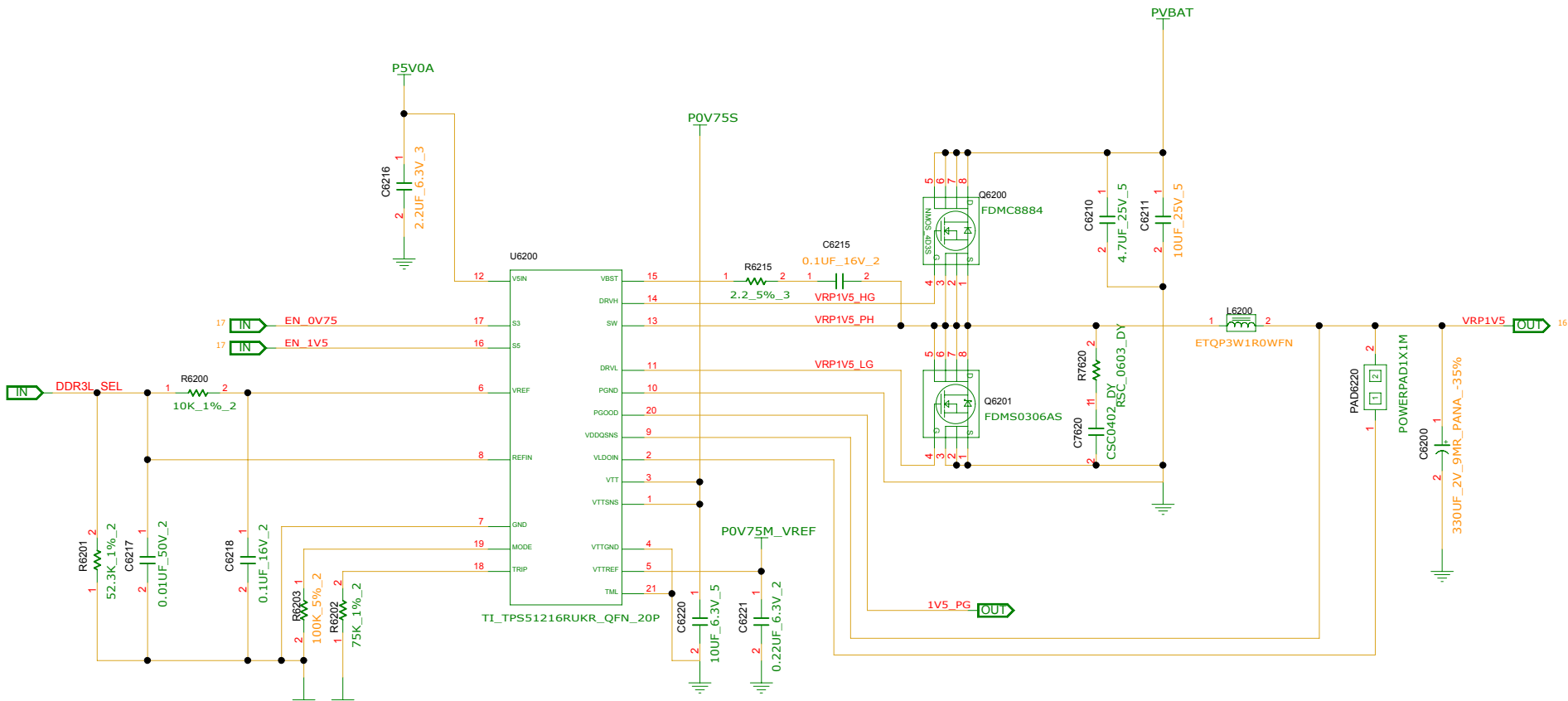

VOUT=REFIN=1.8\*(R6201/(R6200+R6201))  
 MODE=100KOHM:TRACKING DISCHARGE

STATE	S3	S5	VREF	VDDQ	VTTREF	VTT
S0	HI	HI	ON	ON	ON	ON
S3	LO	HI	ON	ON	ON	OFF(High-Z)
S4/S5	LO	LO	OFF	OFF(Discharge)	OFF(Discharge)	OFF(Discharge)

**INVENTEC**

TITLE: MODEL,PROJECT,FUNCTION  
Block Diagram

DOC NUMBER: 1310xxxxx-0-0

REV: X01

CHANGE by: XXX

DATE: 21-OCT-2002

SHEET: 7 of 77

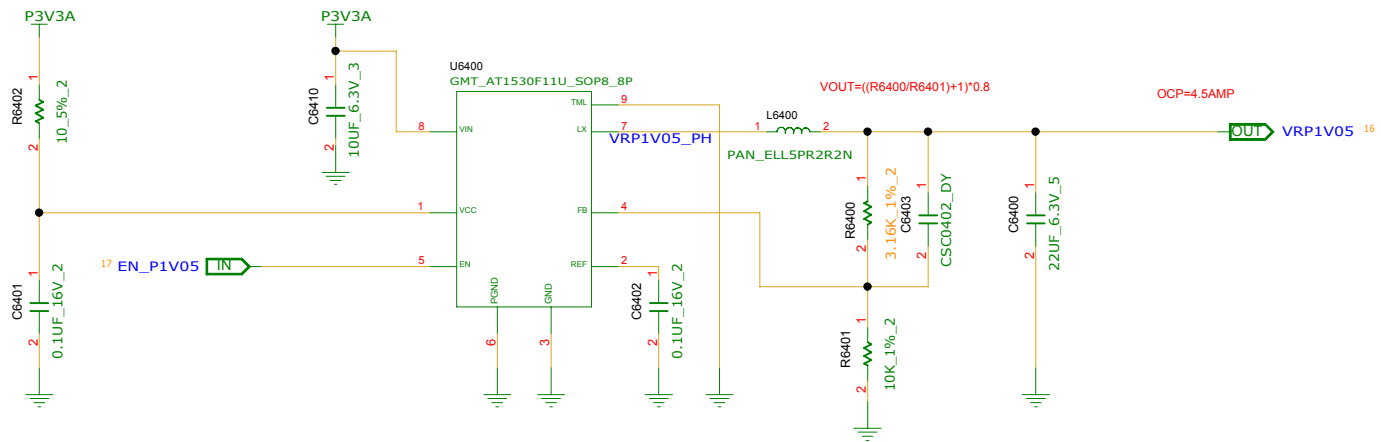

**INVENTEC**

TITLE		
MODEL,PROJECT,FUNCTION Block Diagram		
SIZE A3	CODE CS	DOC NUMBER 1310xxxxx-0-0
		REV X01



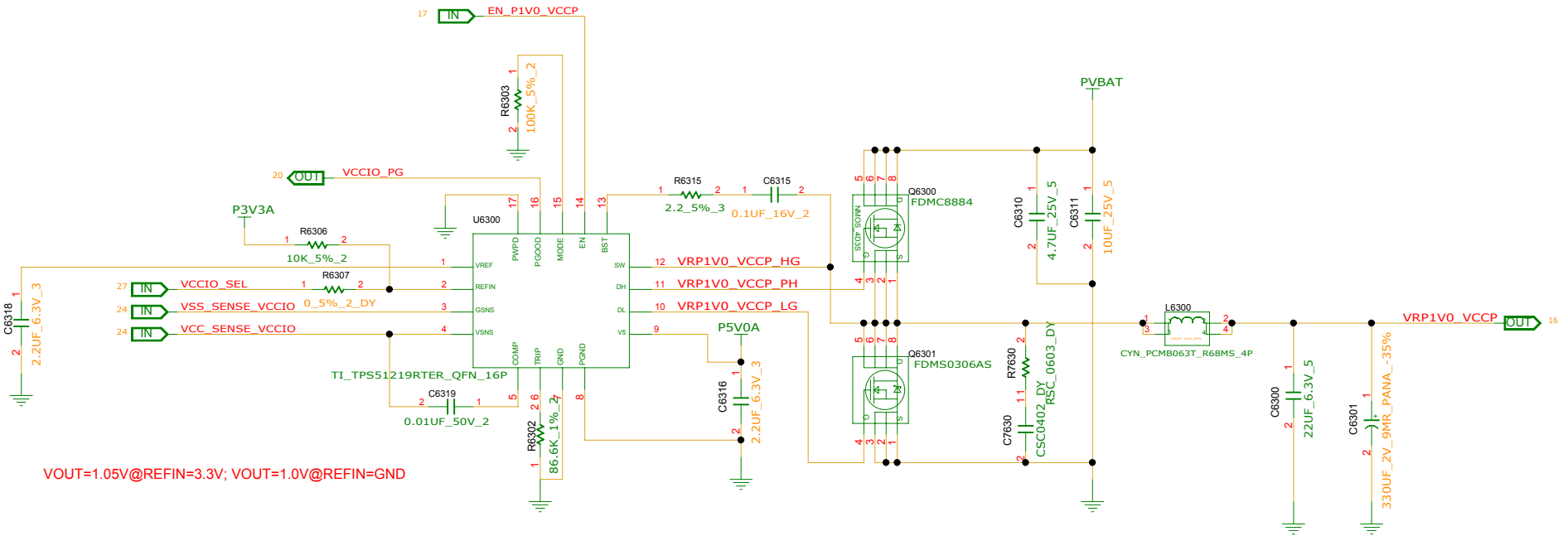

VOUT=1.05V@REFIN=3.3V; VOUT=1.0V@REFIN=GND

<b>INVENTEC</b>			
TITLE MODEL,PROJECT,FUNCTION Block Diagram			
SIZE A3	CODE CS	DOC NUMBER 1310xxxxx-0-0	REV X01
CHANGE by XXX		DATE 21-OCT-2002	SHEET 9 of 77

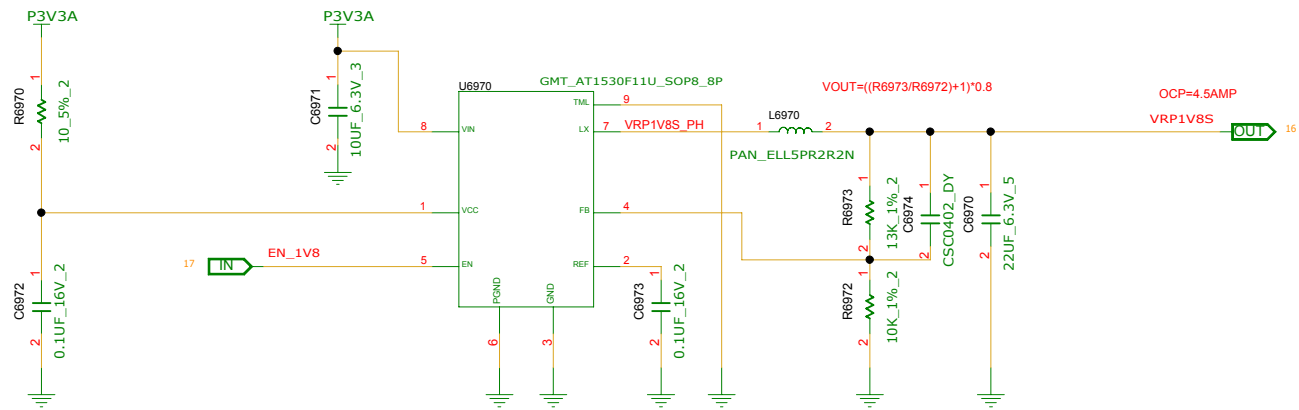

**INVENTEC**

TITLE			
MODEL,PROJECT,FUNCTION			
Block Diagram			
SIZE	CODE	DOC NUMBER	REV
A3	CS	1310xxxx-0-0	X01

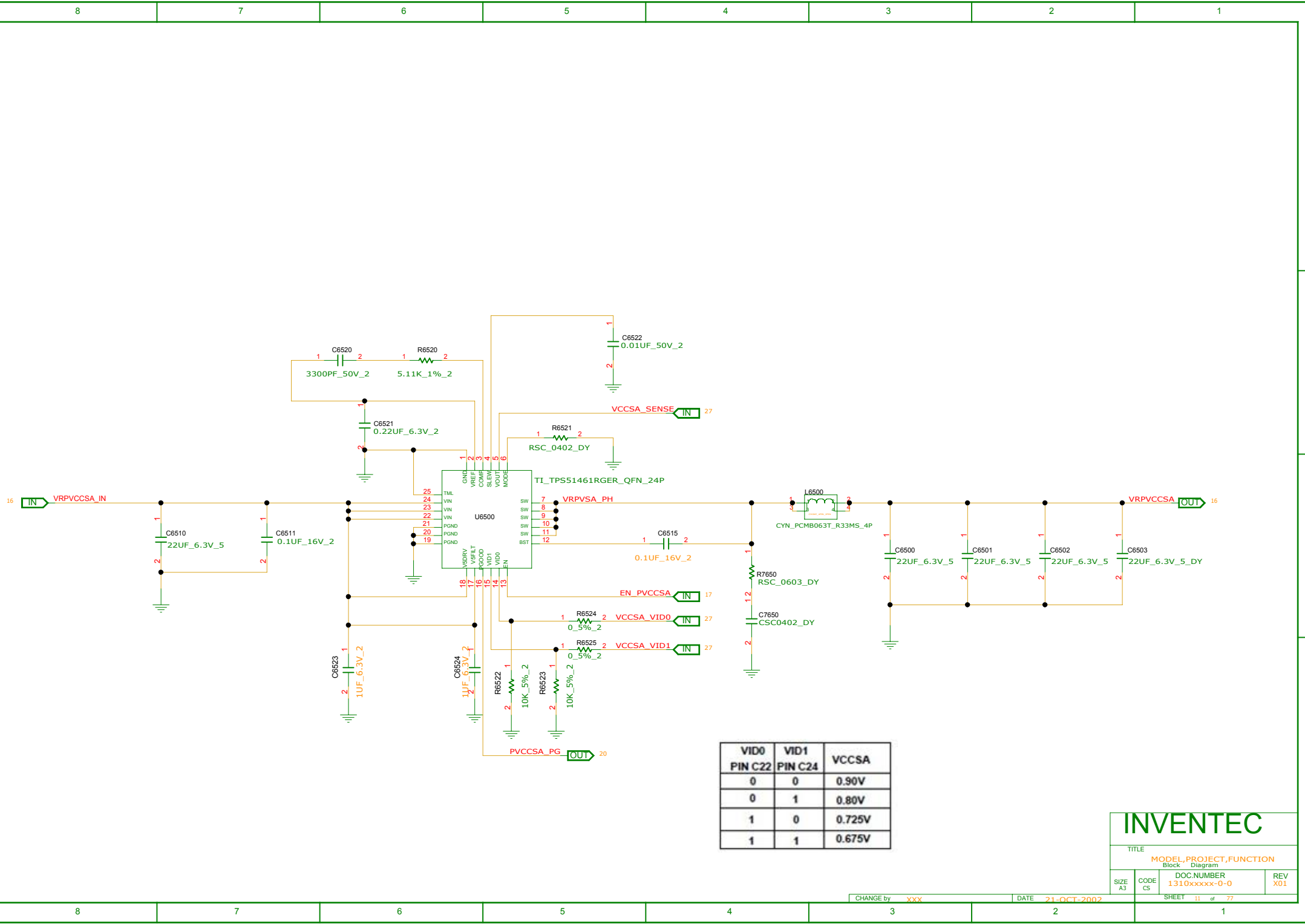

VID0 PIN C22	VID1 PIN C24	VCCSA
0	0	0.90V
0	1	0.80V
1	0	0.725V
1	1	0.675V

**INVENTEC**

TITLE MODEL,PROJECT,FUNCTION Block Diagram			
SIZE A3	CODE CS	DOC NUMBER 1310xxxx-0-0	REV X01

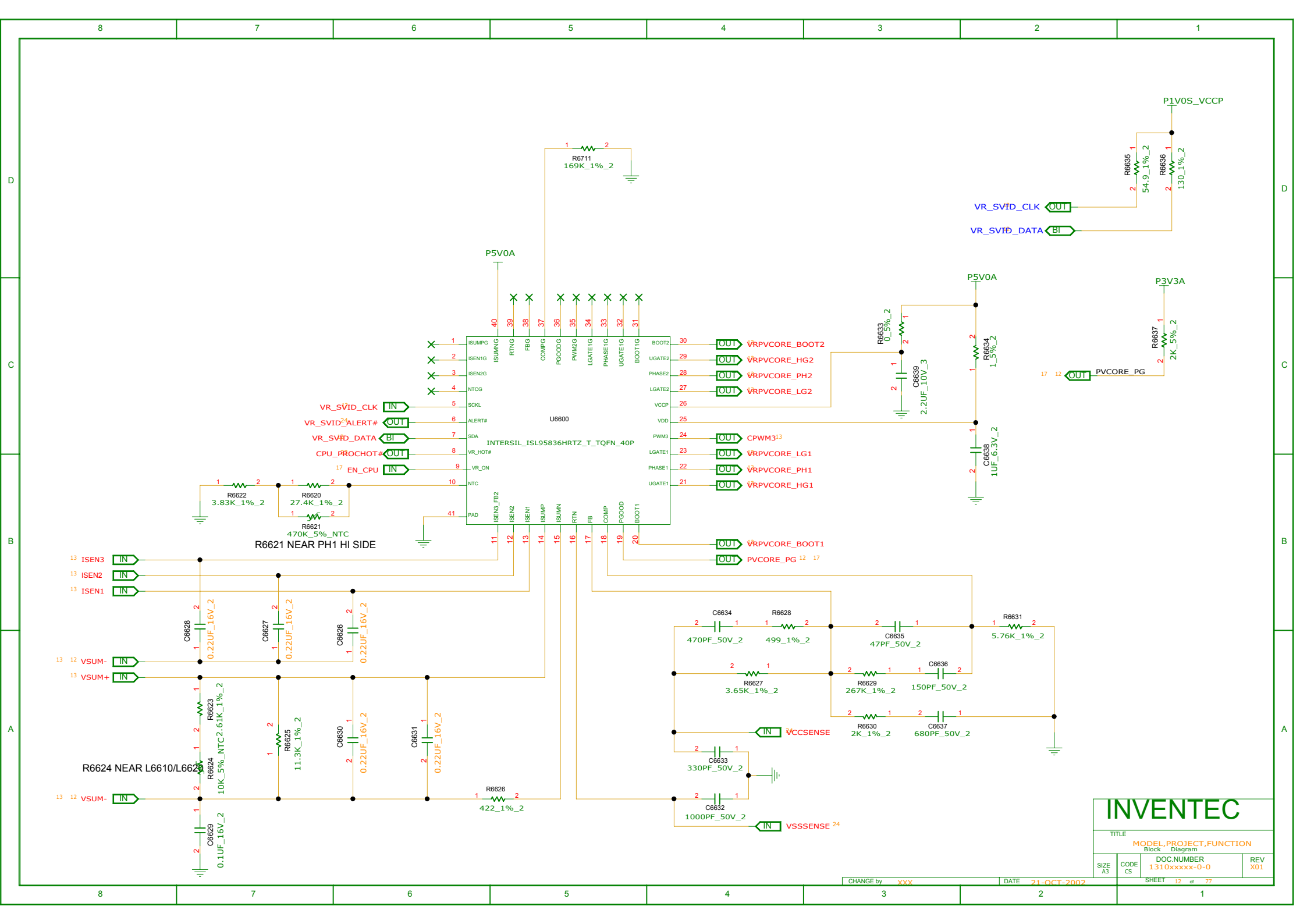

**INVENTEC**

TITLE			
MODEL,PROJECT,FUNCTION			
Block Diagram			
SIZE A3		CODE CS	REV X01
DOC NUMBER 1310xxxxx-0-0		SHEET 12 of 77	

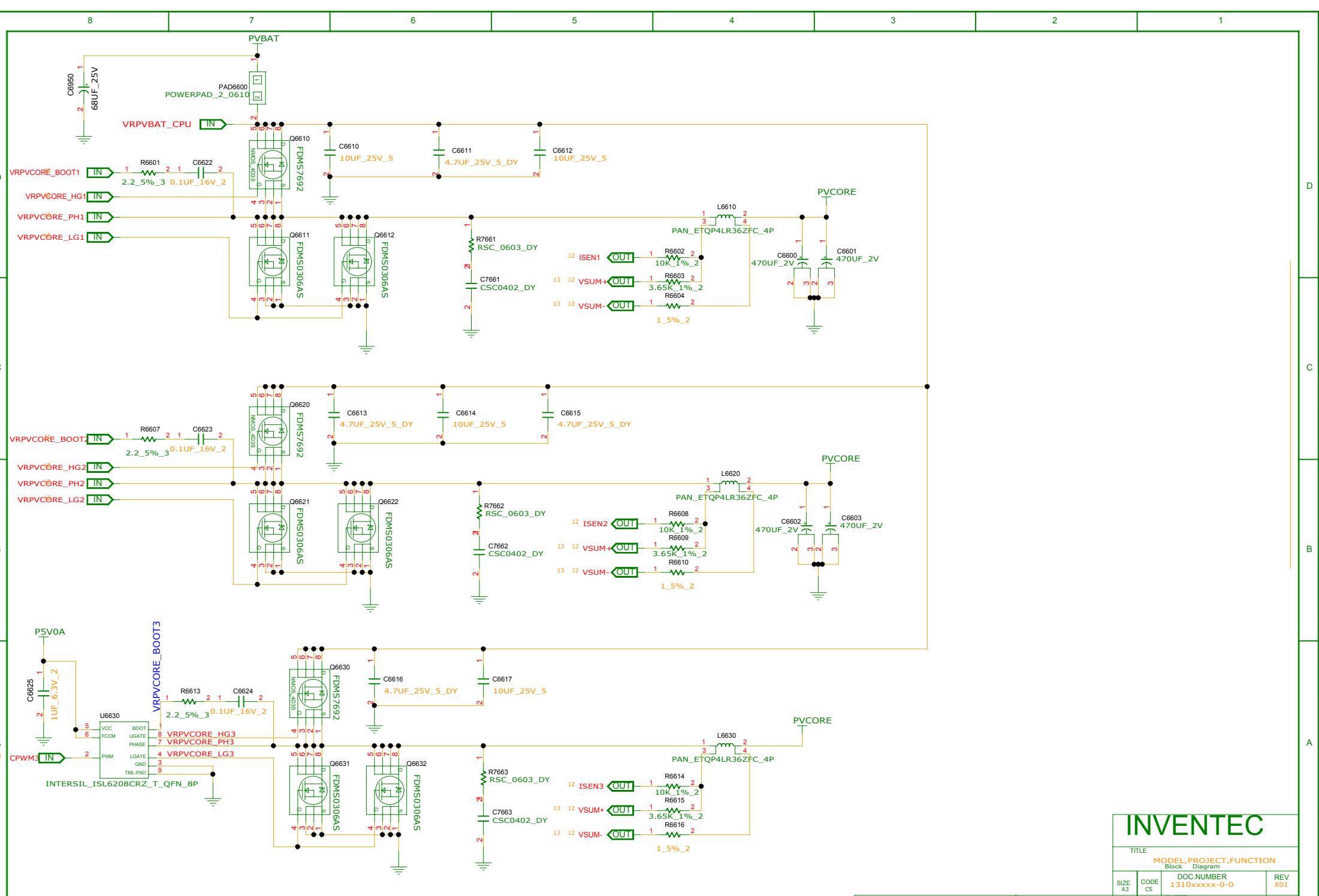

<b>INVENTEC</b>			
TITLE MODEL,PROJECT,FUNCTION Block Diagram			
SIZE A3	CODE CS	DOC NUMBER 1310xxxxx-0-0	REV X01
CHANGE by XXX		DATE 21-OCT-2002	SHEET 13 of 77

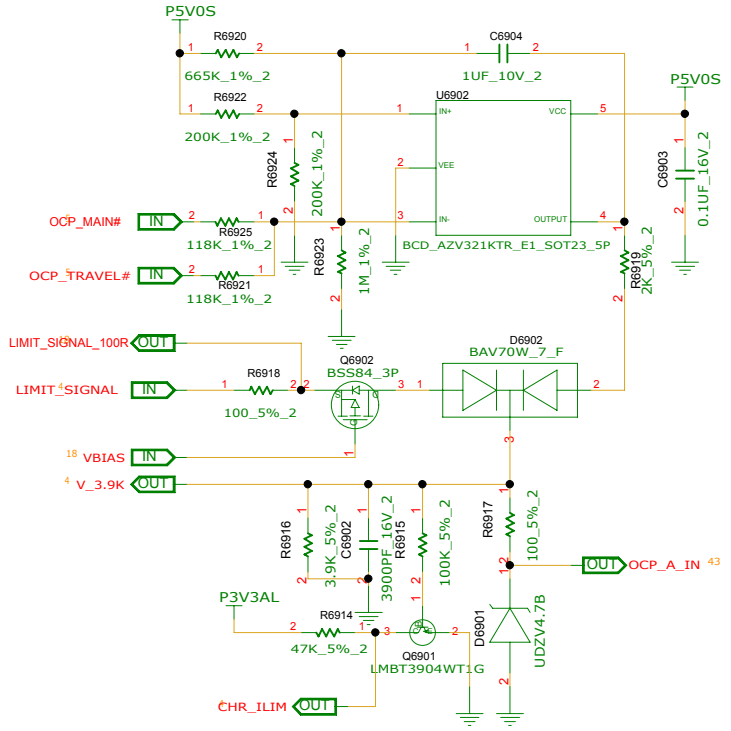
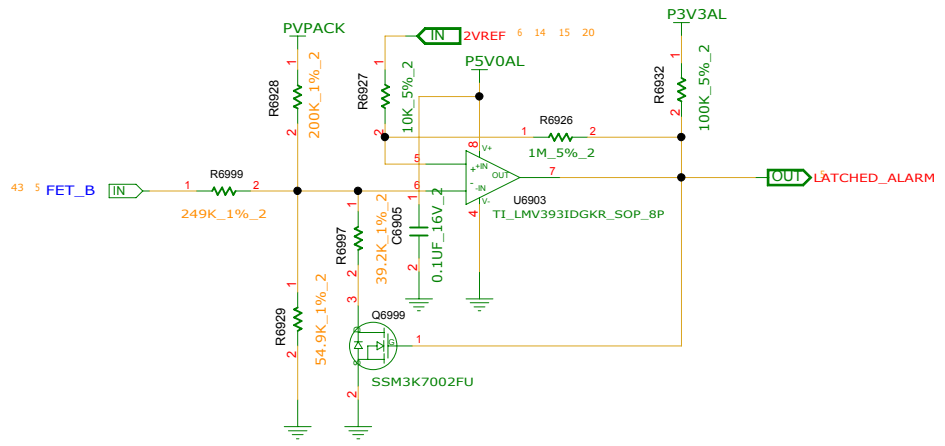
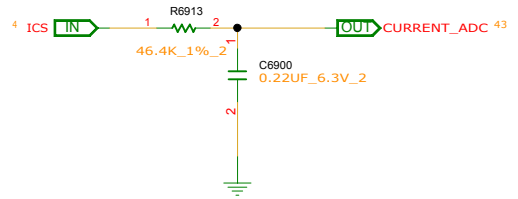
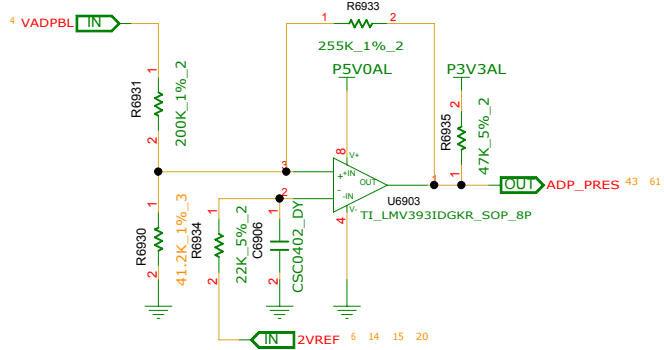

<b>INVENTEC</b>			
TITLE MODEL PROJECT FUNCTION SYSTEM POWER(OCP)			
SIZE A3	CODE CS	DOC NUMBER 1310xxxxx-0-0	REV X01
CHANGE by XXX		DATE 21-OCT-2002	SHEET 14 of 77

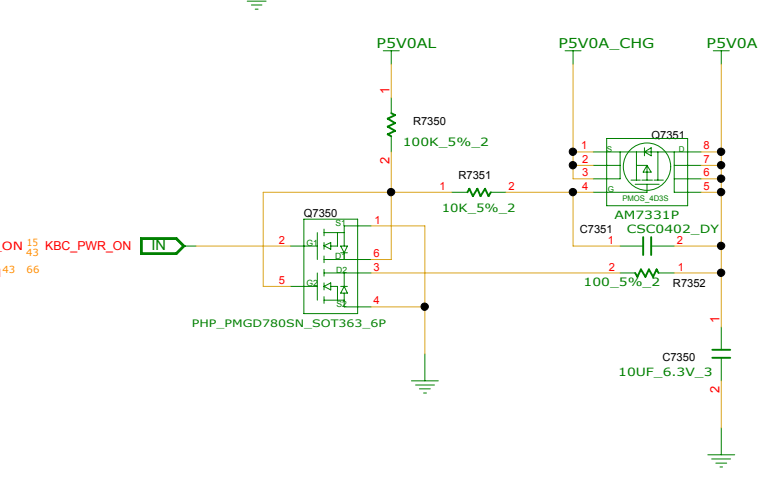
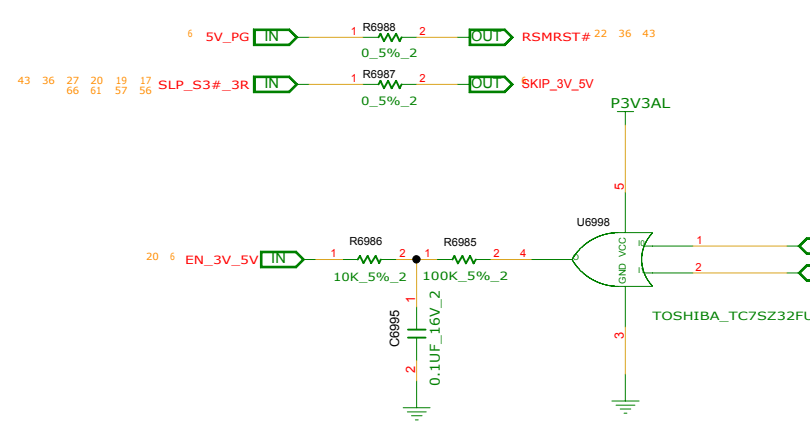
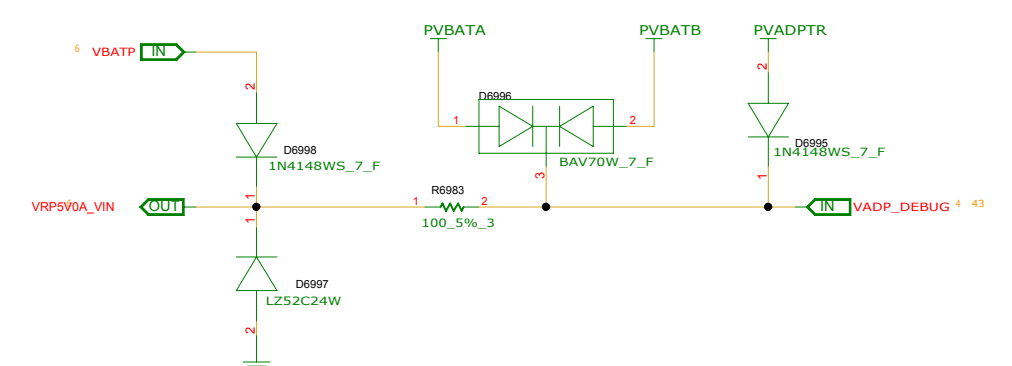
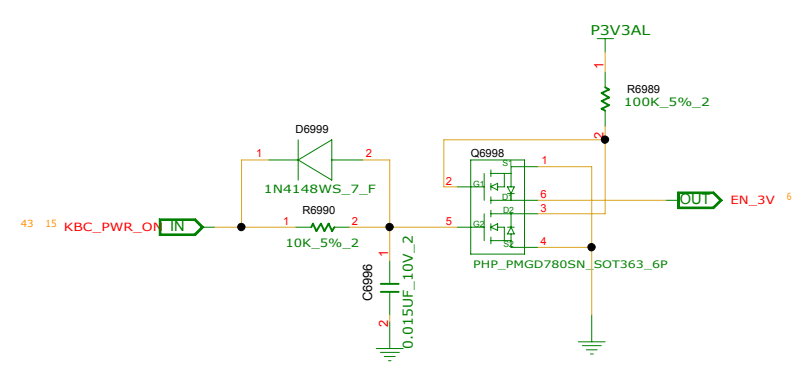
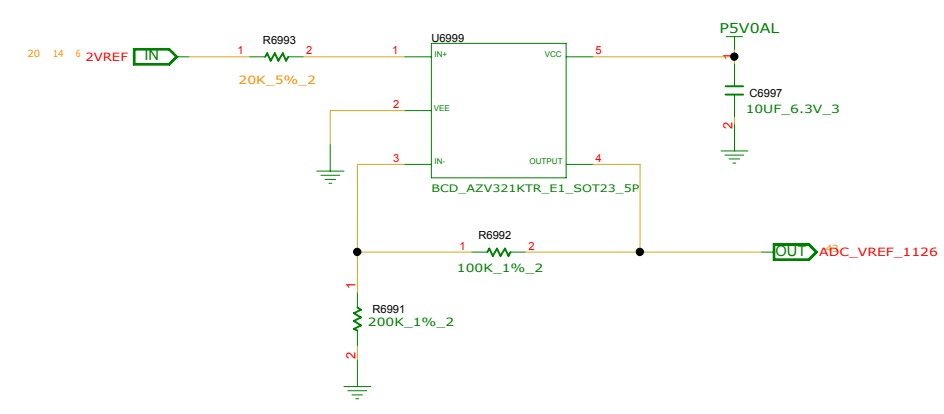
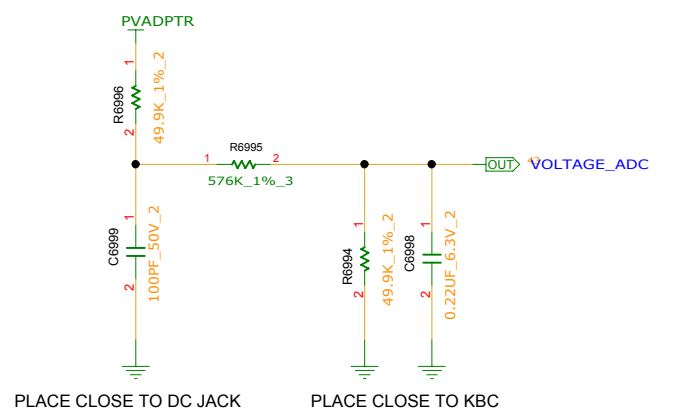

<b>INVENTEC</b>			
TITLE MODEL PROJECT FUNCTION P3V5A&P5V0A_CHG_PORT			
SIZE A3		CODE CS	
DOC NUMBER 1310xxxx-0-0		REV X01	
CHANGE by XXX		DATE 21-OCT-2002	
SHEET 15 of 77			

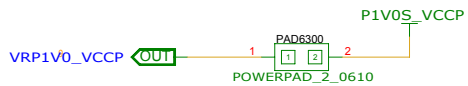
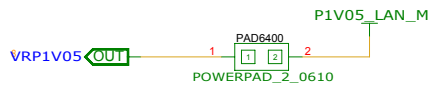
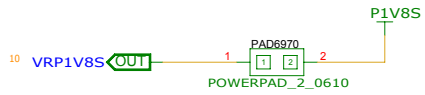
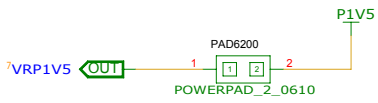
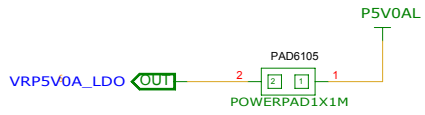
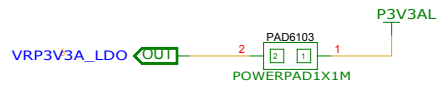
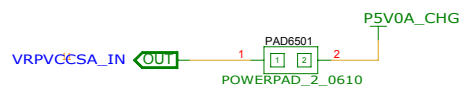
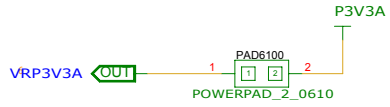
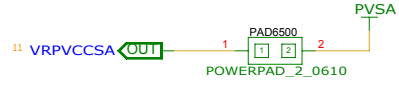
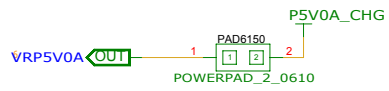

**INVENTEC**

TITLE			
MODEL,PROJECT,FUNCTION Block Diagram			
SIZE	CODE	DOC NUMBER	REV
A3	CS	1310xxxxx-0-0	X01



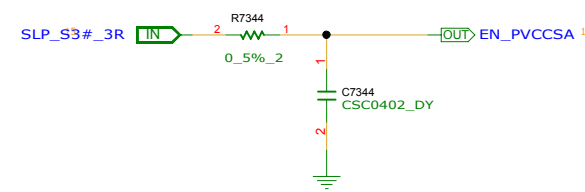
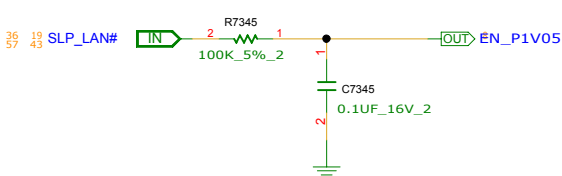
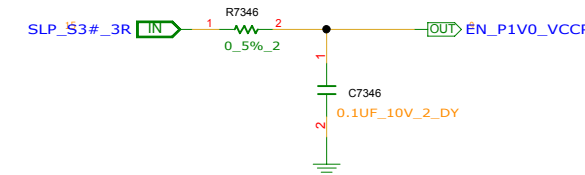
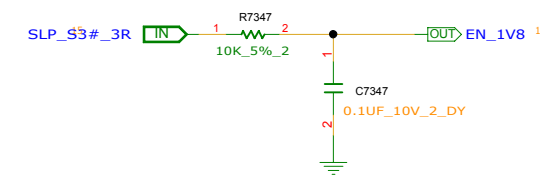
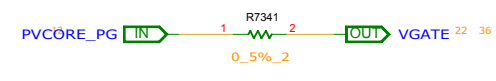
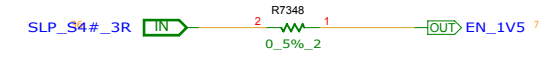
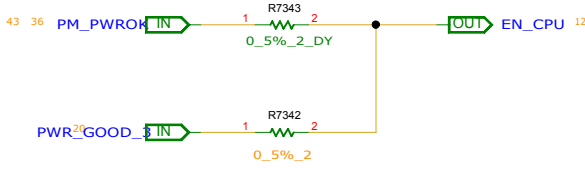
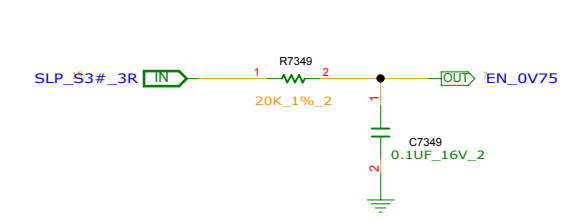

<b>INVENTEC</b>			
TITLE MODEL,PROJECT,FUNCTION Block Diagram			
SIZE A3	CODE CS	DOC NUMBER 1310xxxxx-0-0	REV X01
CHANGE by XXX		DATE 21-OCT-2002	SHEET 17 of 77

REFERENCE NUMBER : 6900~6999

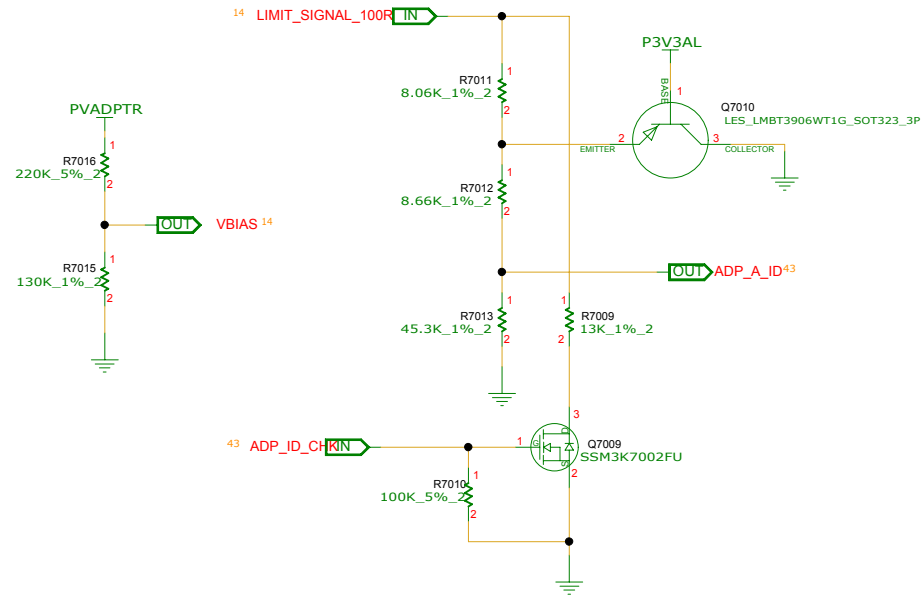

**INVENTEC**

TITLE			
MODEL,PROJECT,FUNCTION			
HP_OCP			
SIZE	CODE	DOC NUMBER	REV
A3	CS	1310xxxxx-0-0	X01

REFERENCE NUMER : 7000~7350

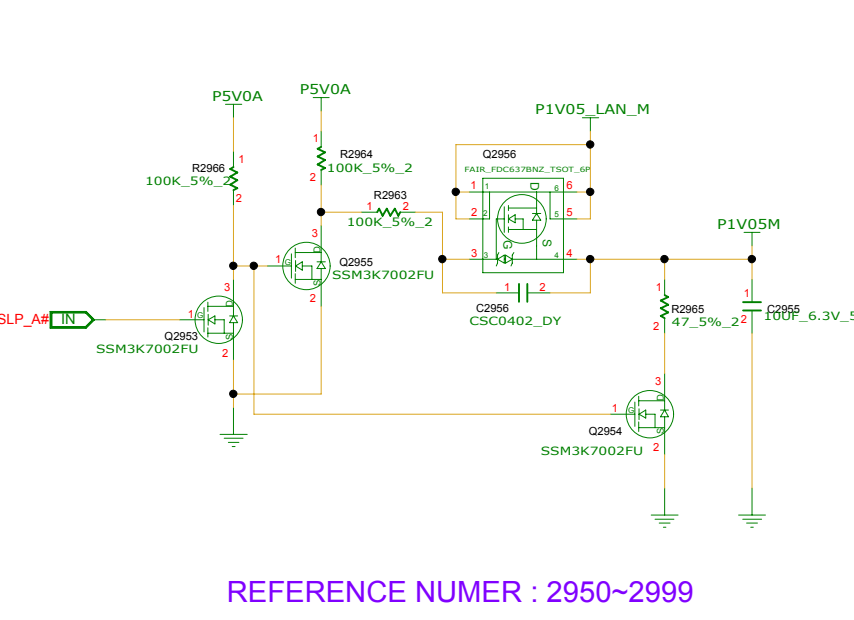
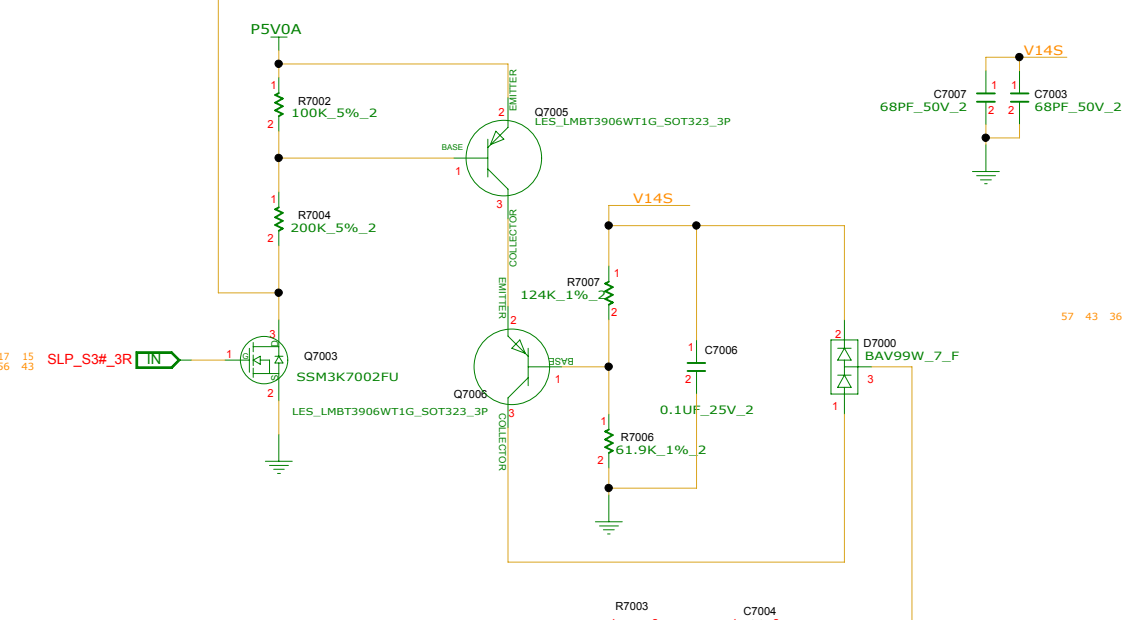
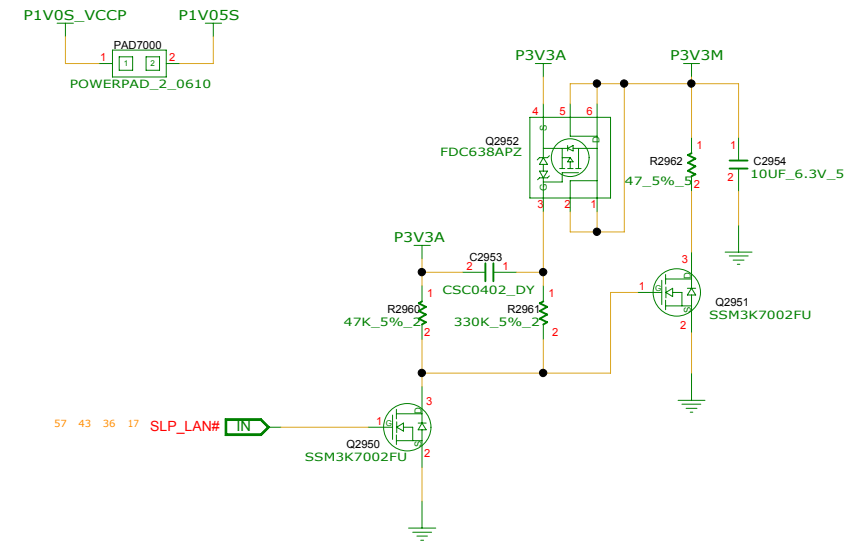
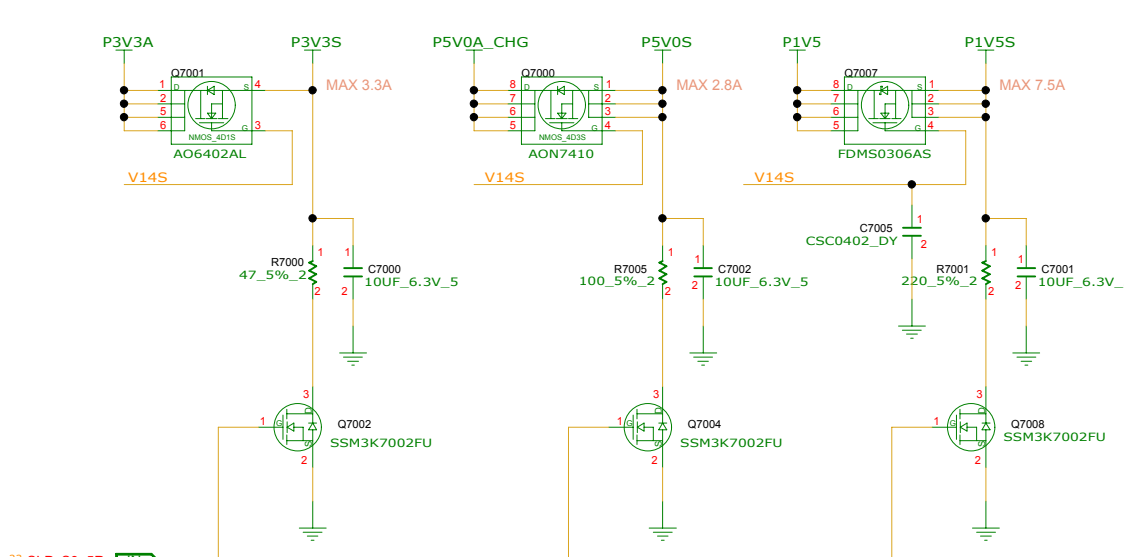

REFERENCE NUMER : 2950~2999

<b>INVENTEC</b>			
TITLE			
MODEL PROJECT,FUNCTION POWER(SLEEP)			
SIZE A3	CODE CS	DOC NUMBER 1310xxxxx-0-0	REV X01
CHANGE by XXX		DATE 21-OCT-2002	SHEET 19 of 77

REFERENCE NUMBER : 7400~7450

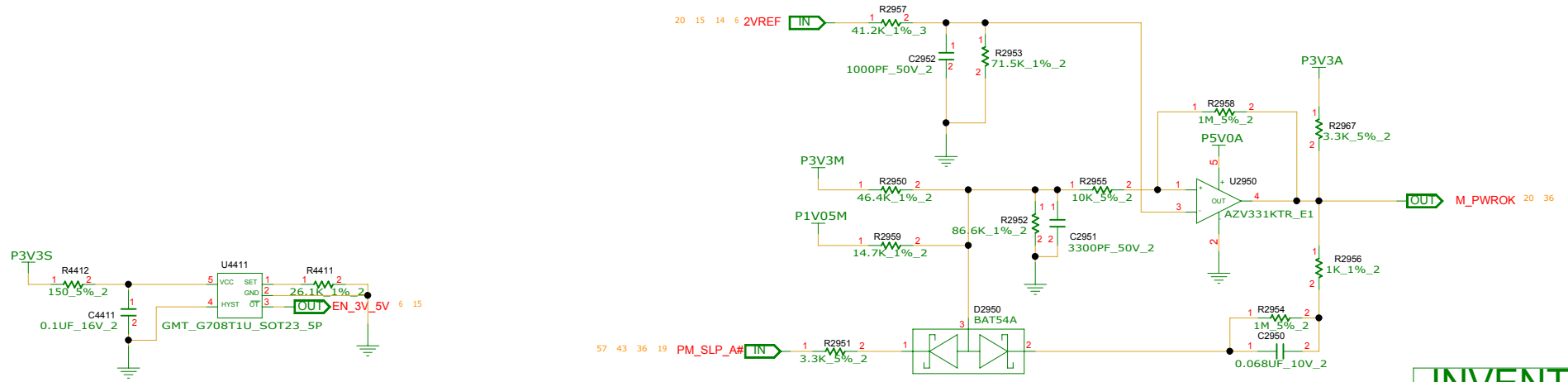
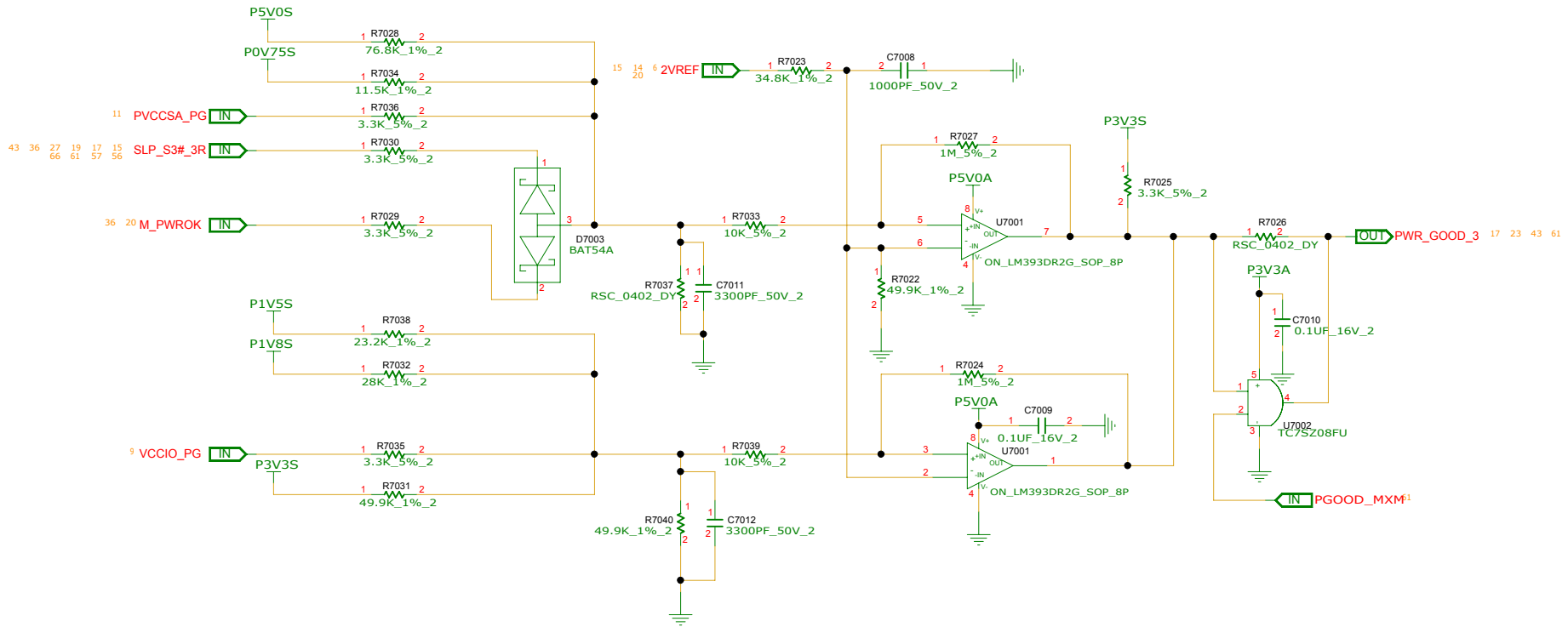

FOR IAMT

REFERENCE NUMBER : 2950~2999

<b>INVENTEC</b>			
TITLE			
MODEL PROJECT,FUNCTION POWER (SEQUENCE)			
SIZE A3		CODE CS	
DOC NUMBER 1310xxxxx-0-0		REV X01	
SHEET 20 of 77			

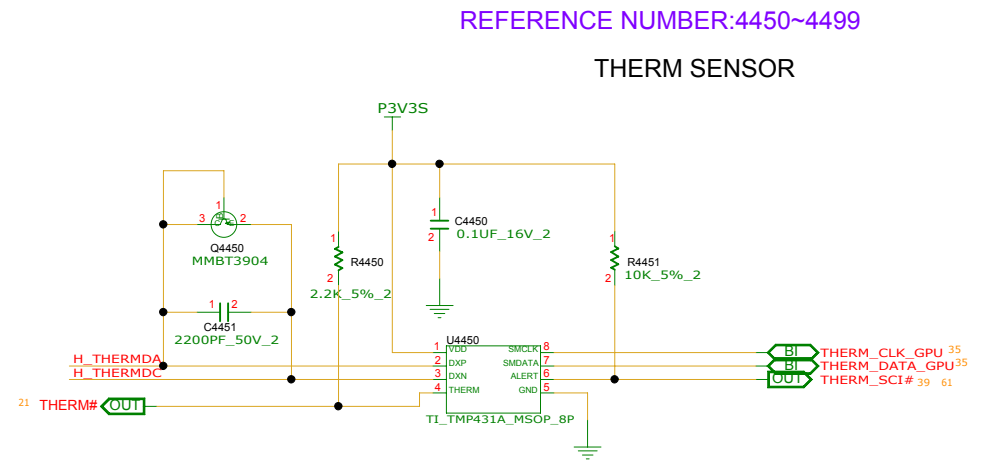
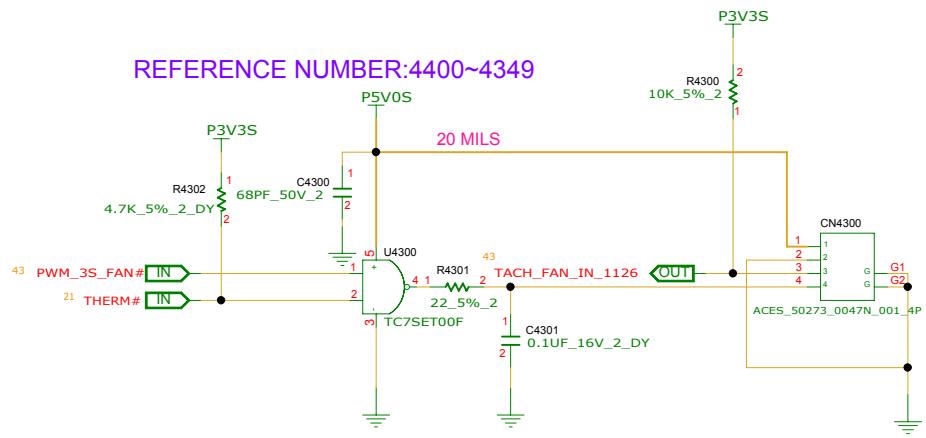

Fan speeds (RPM) :	2500	3300	3800	4300	5000	0	0	0
CPU temperature trip points :	45	57	68	80	91	0	0	0

**INVENTEC**

TITLE  
MODEL PROJECT,FUNCTION  
FAN & THERMAL

DOC NUMBER  
1310xxxxx-0-0

REV  
X01

CHANGE by XXX DATE 21-OCT-2002 SHEET 21 of 77

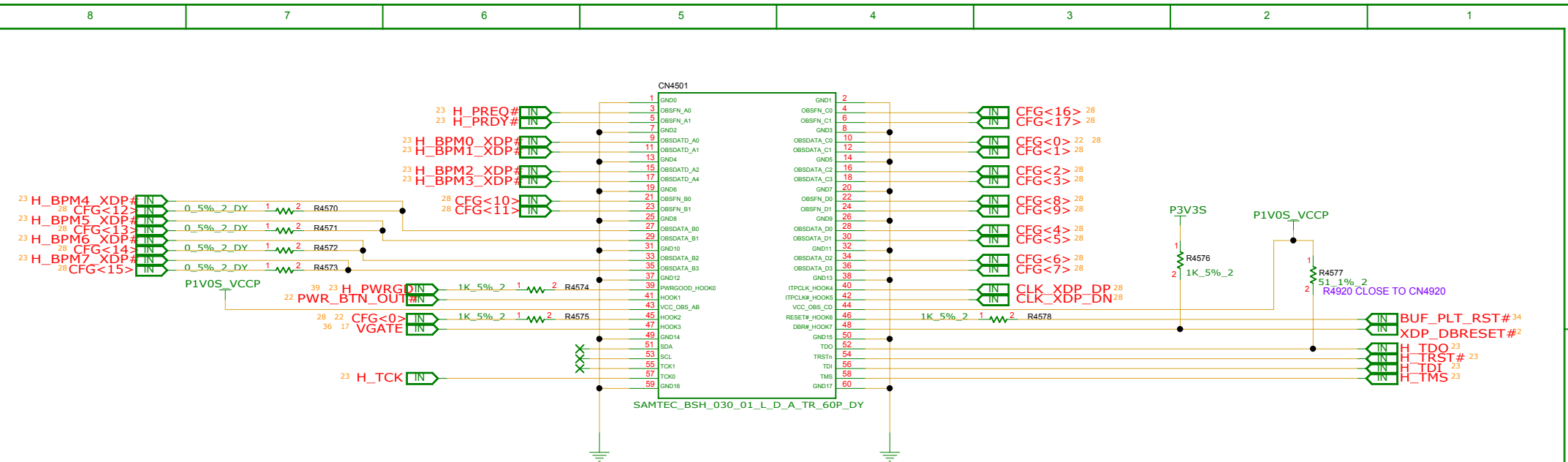

## CPU XDP CONNECTOR

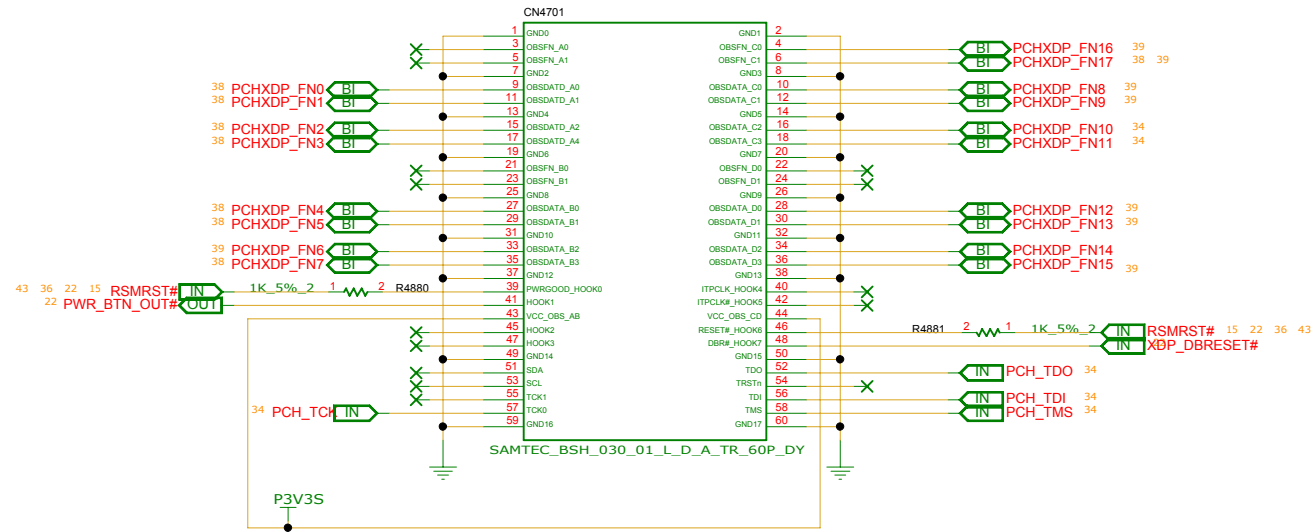

## PCH XDP CONNECTOR

<b>INVENTEC</b>			
TITLE			
MODEL PROJECT,FUNCTION			
XDP_CONN			
SIZE	CODE	DOC NUMBER	REV
A3	CS	1310xxxx-0-0	X01
SHEET 22 of 77			

REFERENCE NUMBER:4500~4699

CN4500 CPU RPGA 989 SOCKET SUPPORT SANDY BRIDGE & IVY BRIDGE

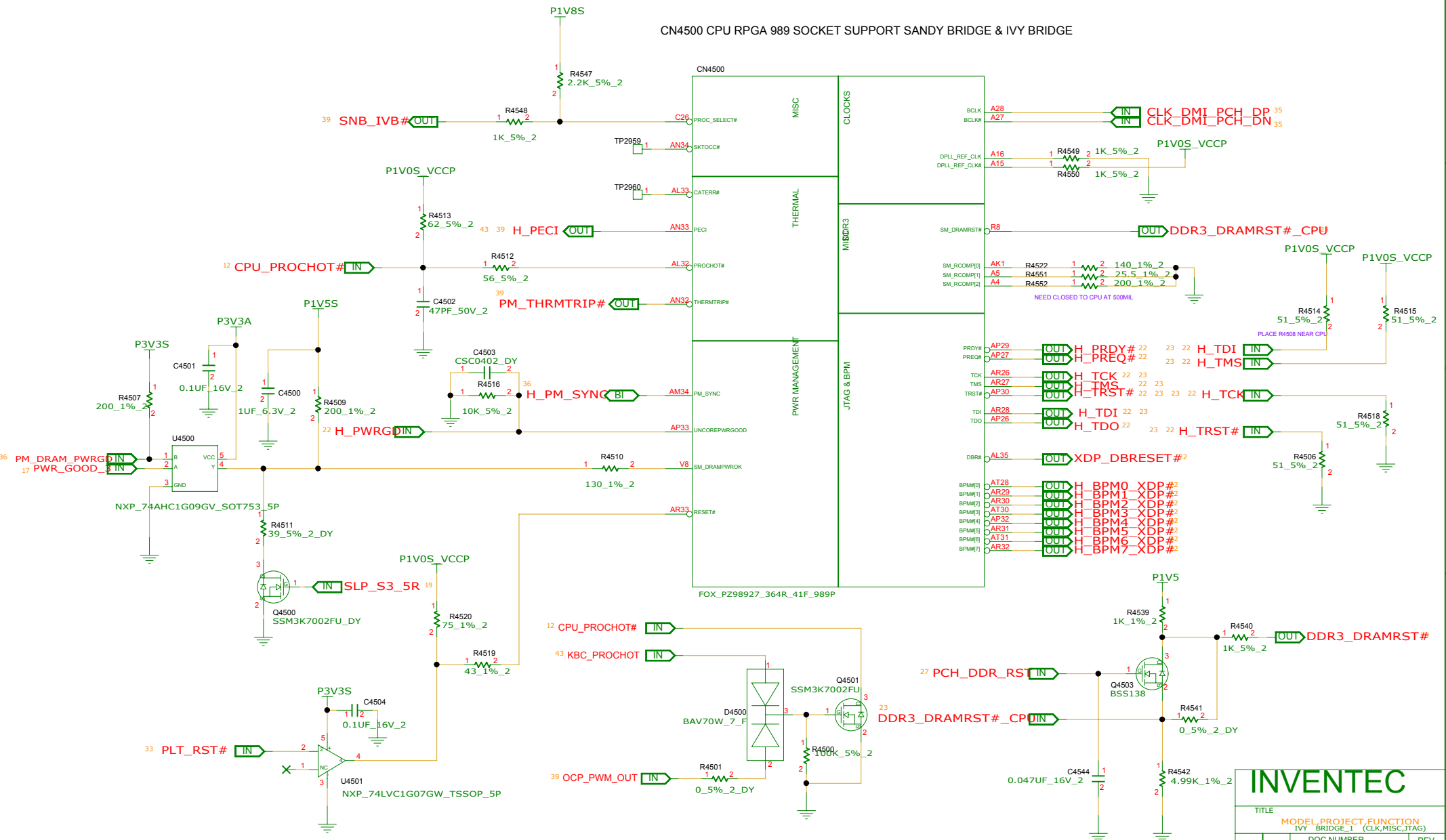

<b>INVENTEC</b>			
TITLE			
MODEL PROJECT FUNCTION			
IVY BRIDGE 1 (CLK,MISC,JTAG)			
DOC NUMBER			
1310xxxxx-0-0			
REV			
X01			
SIZE	CODE	DATE	SHEET
A3	CS	21-OCT-2002	23 of 77

REFERENCE NUMBER:4500~4699

- CN4500
- AG35 VCC1
  - AG34 VCC2
  - AG33 VCC3
  - AG32 VCC4
  - AG31 VCC5
  - AG30 VCC6
  - AG29 VCC7
  - AG28 VCC8
  - AG27 VCC9
  - AG26 VCC10
  - AF35 VCC11
  - AF34 VCC12
  - AF33 VCC13
  - AF32 VCC14
  - AF31 VCC15
  - AF30 VCC16
  - AF29 VCC17
  - AF28 VCC18
  - AF27 VCC19
  - AD35 VCC20
  - AD34 VCC21
  - AD33 VCC22
  - AD32 VCC23
  - AD31 VCC24
  - AD30 VCC25
  - AD29 VCC26
  - AD28 VCC27
  - AD27 VCC28
  - AD26 VCC29
  - AC35 VCC30
  - AC34 VCC31
  - AC33 VCC32
  - AC32 VCC33
  - AC31 VCC34
  - AC30 VCC35
  - AC29 VCC36
  - AC28 VCC37
  - AC27 VCC38
  - AC26 VCC39
  - AA35 VCC40
  - AA34 VCC41
  - AA33 VCC42
  - AA32 VCC43
  - AA31 VCC44
  - AA30 VCC45
  - AA29 VCC46
  - AA28 VCC47
  - AA27 VCC48
  - AA26 VCC49
  - Y35 VCC50
  - Y34 VCC51
  - Y33 VCC52
  - Y32 VCC53
  - Y31 VCC54
  - Y30 VCC55
  - Y29 VCC56
  - Y28 VCC57
  - Y27 VCC58
  - Y26 VCC59
  - Y25 VCC60
  - V35 VCC61
  - V34 VCC62
  - V33 VCC63
  - V32 VCC64
  - V31 VCC65
  - V30 VCC66
  - V29 VCC67
  - V28 VCC68
  - V27 VCC69
  - V26 VCC70
  - U35 VCC71
  - U34 VCC72
  - U33 VCC73
  - U32 VCC74
  - U31 VCC75
  - U30 VCC76
  - U29 VCC77
  - U28 VCC78
  - U27 VCC79
  - U26 VCC80
  - R35 VCC81
  - R34 VCC82
  - R33 VCC83
  - R32 VCC84
  - R31 VCC85
  - R30 VCC86
  - R29 VCC87
  - R28 VCC88
  - R27 VCC89
  - R26 VCC90
  - P35 VCC91
  - P34 VCC92
  - P33 VCC93
  - P32 VCC94
  - P31 VCC95
  - P30 VCC96
  - P29 VCC97
  - P28 VCC98
  - P27 VCC99
  - P26 VCC100

POWER

PEG AND DDR

CORE SUPPLY

SVID

SENSE LINES

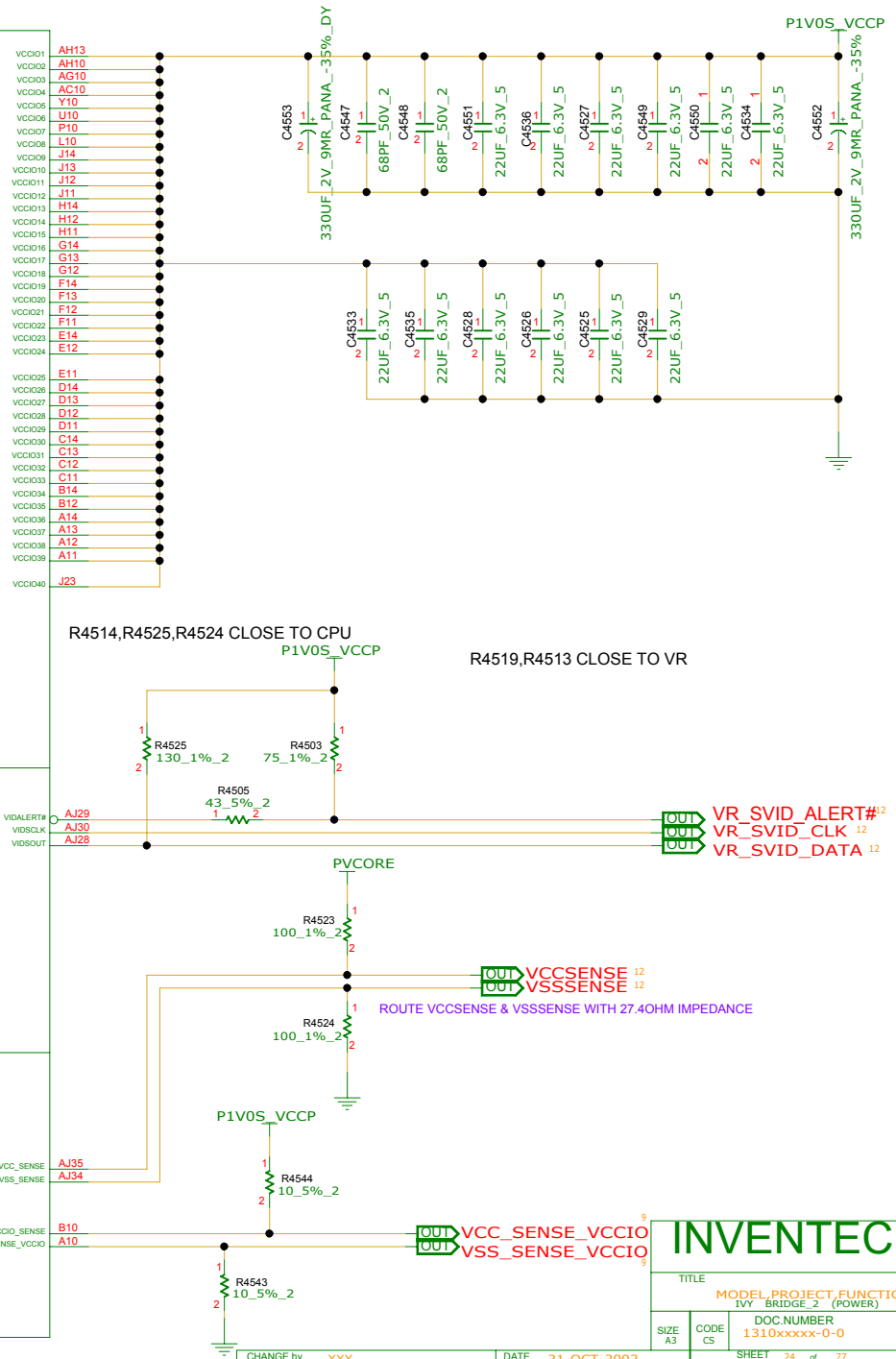

**INVENTEC**

TITLE: MODEL\_PROJECT\_FUNCTION  
I7Y\_BRIDGE\_2 (POWER)

DOC NUMBER: 1310xxxx-0-0

REV: X01

SIZE: A3

CODE: CS

CHANGE by: XXX

DATE: 21-OCT-2002

SHEET: 24 of 77



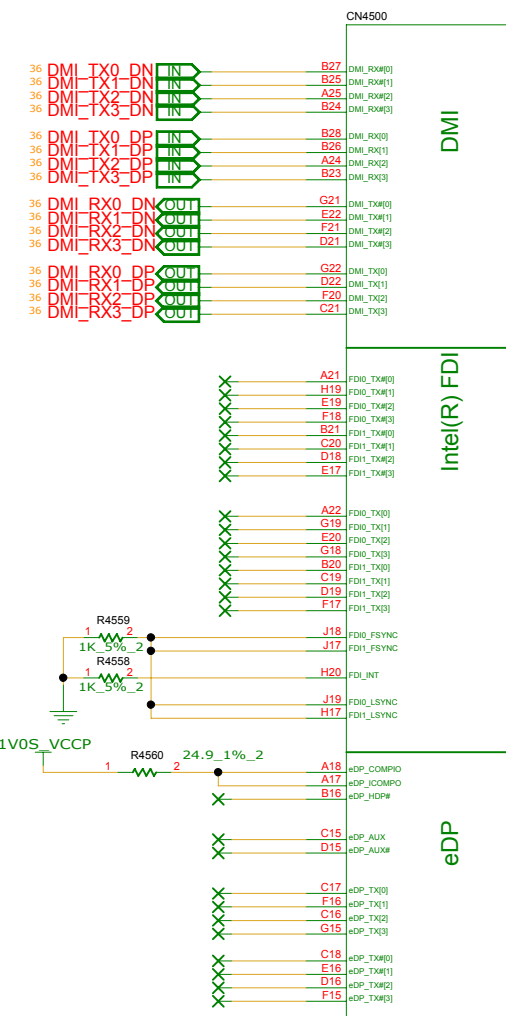

PCI EXPRESS\* - GRAPHICS

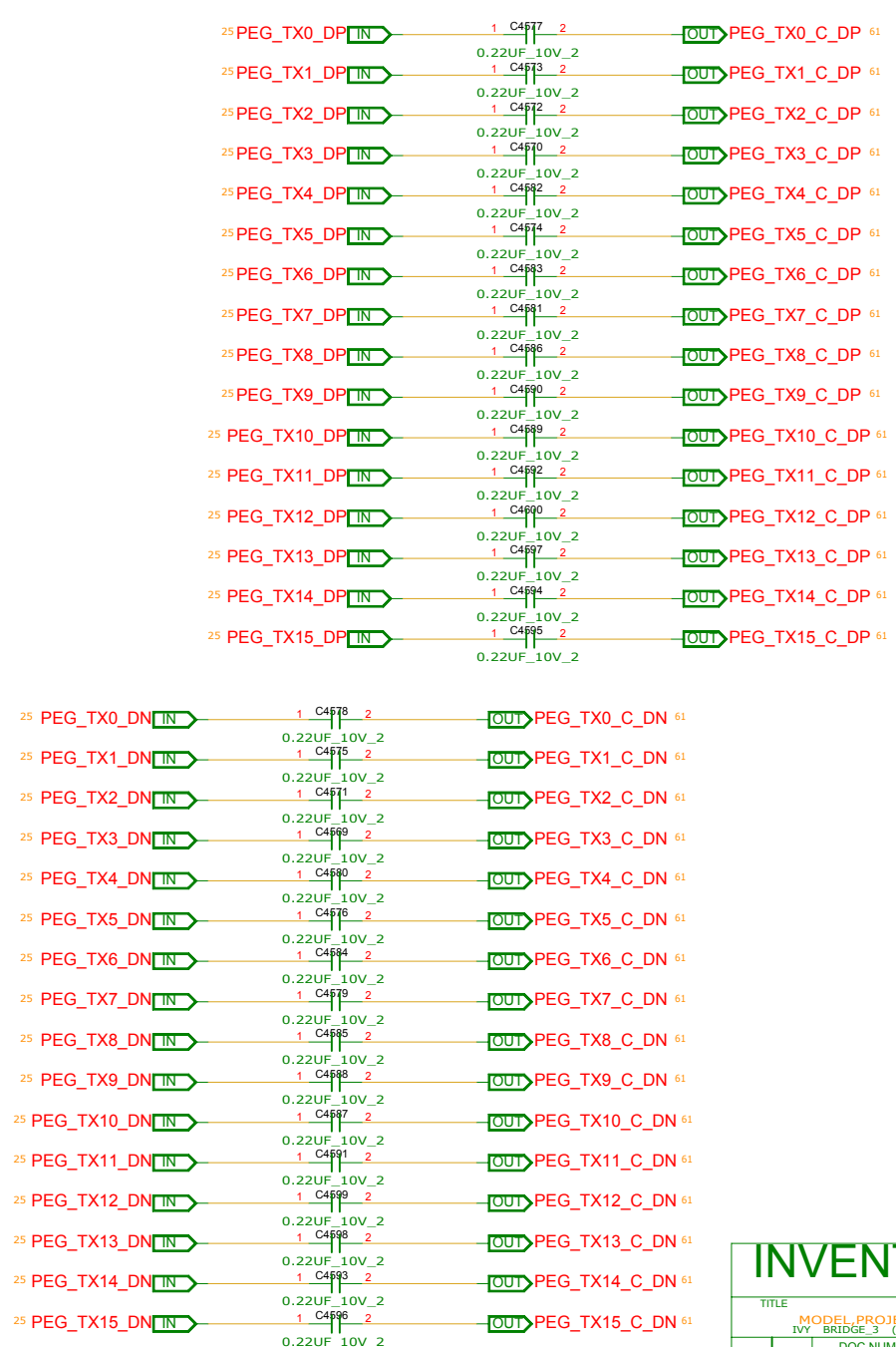
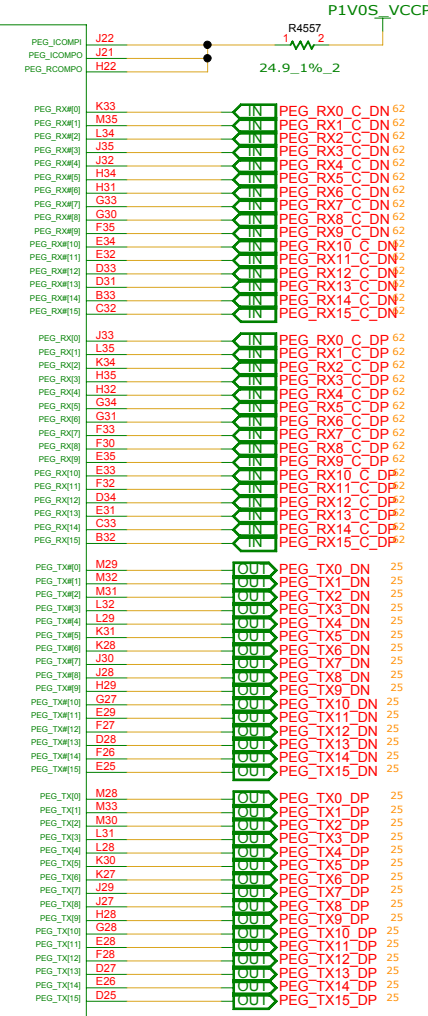

REFERENCE NUMBER:4500~4699

**INVENTEC**

TITLE MODEL PROJECT FUNCTION  
Ivy BRIDGE\_3 (DMI,DP,PEG,FDI)

SIZE A3	CODE CS	DOC NUMBER 1310xxxxx-0-0	REV X01
---------	---------	--------------------------	---------

CHANGE by XXX DATE 21-OCT-2002 SHEET 25 of 77

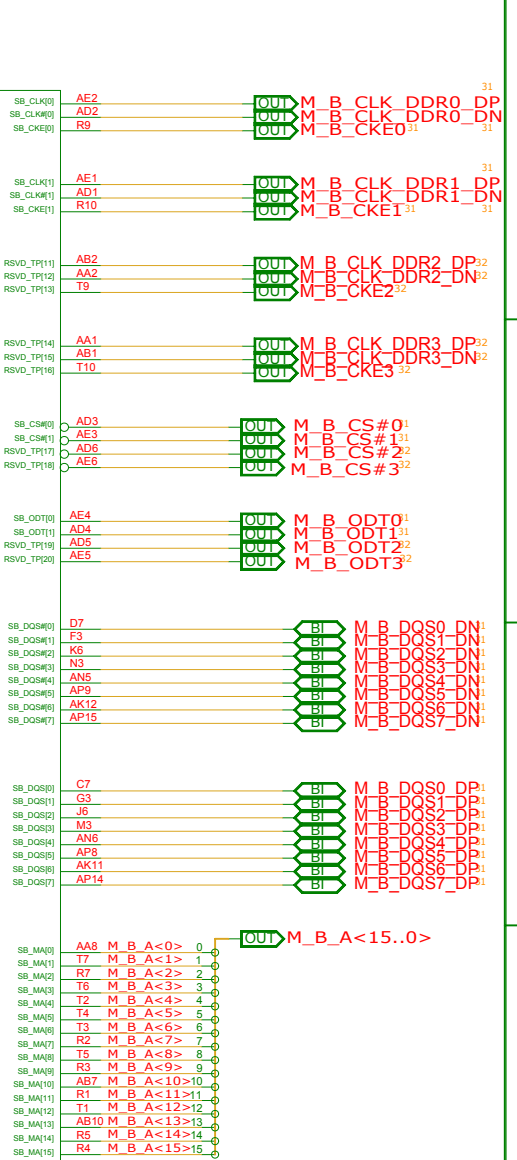
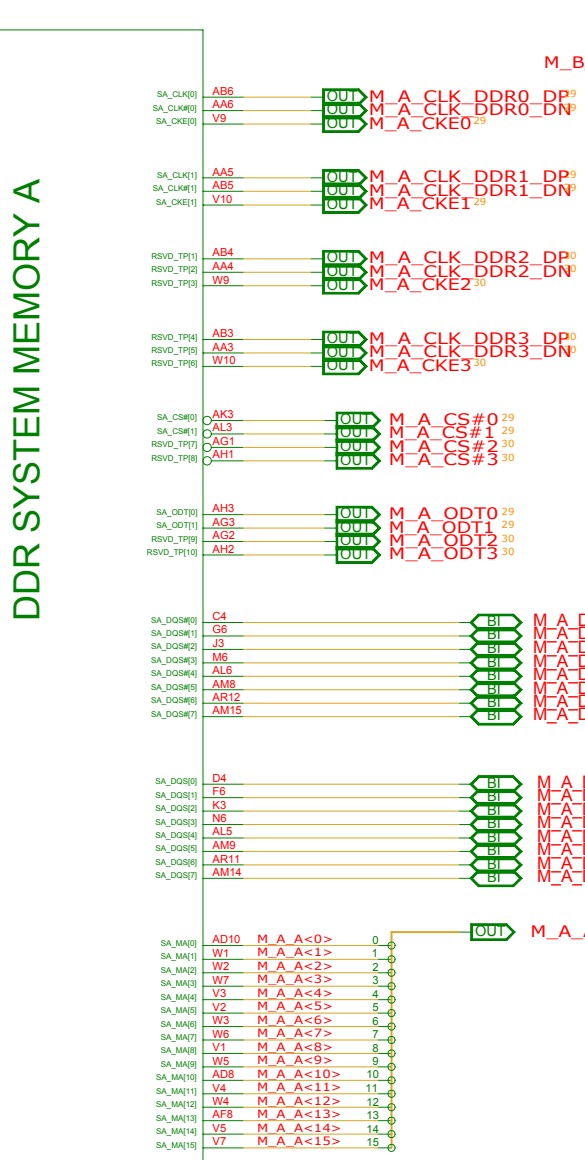
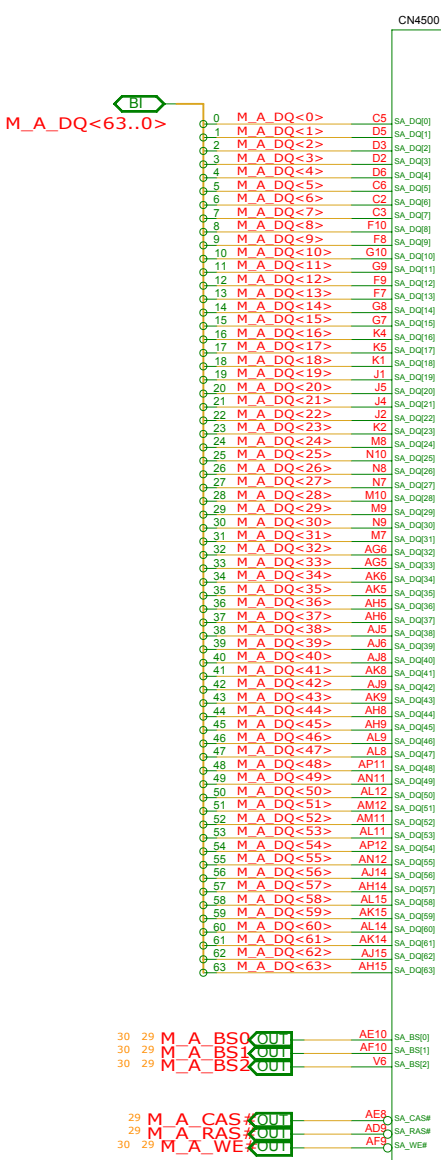

REFERENCE NUMBER:4500~4699

**INVENTEC**

TITLE  
 MODEL PROJECT FUNCTION  
 I/W BRIDGE 4 (DDR3)

SIZE A3	CODE CS	DOC NUMBER 1310xxxxx-0-0	REV X01
---------	---------	--------------------------	---------

CHANGE by XXX DATE 21-OCT-2002 SHEET 26 of 77

REFERENCE NUMBER:4500~4699

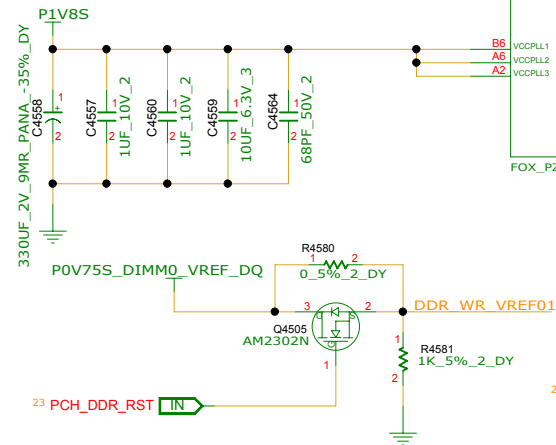
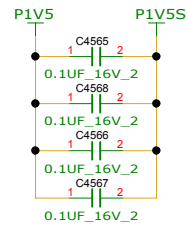

CN4500

POWER

LINES

SENSE

VREF

GRAPHICS

DDR3-1.5VRAILS

SA RAIL

1.8VRAIL

MISC

FOX\_P298927\_364R\_41F\_989P

- VAXG1 AT2
- VAXG2 AT2
- VAXG3 AT2
- VAXG4 AT2
- VAXG5 AT1
- VAXG6 AT1
- VAXG7 AR2
- VAXG8 AR2
- VAXG9 AR2
- VAXG10 AR2
- VAXG11 AR1
- VAXG12 AR1
- VAXG13 AP2
- VAXG14 AP2
- VAXG15 AP2
- VAXG16 AP2
- VAXG17 AP1
- VAXG18 AN2
- VAXG19 AN2
- VAXG20 AN2
- VAXG21 AN2
- VAXG22 AN2
- VAXG23 AN1
- VAXG24 AM2
- VAXG25 AM2
- VAXG26 AM2
- VAXG27 AM2
- VAXG28 AM1
- VAXG29 AM1
- VAXG30 AL2
- VAXG31 AL2
- VAXG32 AL2
- VAXG33 AL2
- VAXG34 AL2
- VAXG35 AL1
- VAXG36 AL1
- VAXG37 AK2
- VAXG38 AK2
- VAXG39 AK2
- VAXG40 AK2
- VAXG41 AK1
- VAXG42 AK1
- VAXG43 AJ2
- VAXG44 AJ2
- VAXG45 AJ2
- VAXG46 AJ2
- VAXG47 AJ1
- VAXG48 AH2
- VAXG49 AH2
- VAXG50 AH2
- VAXG51 AH2
- VAXG52 AH2
- VAXG53 AH1
- VAXG54 AH1
- VAXG55 AH1

- VDD01 AF7
- VDD02 AF4
- VDD03 AF1
- VDD04 AC7
- VDD05 AC4
- VDD06 AC1
- VDD07 Y7
- VDD08 Y4
- VDD09 Y1
- VDD10 U7
- VDD11 U4
- VDD12 U1
- VDD13 P7
- VDD14 P4
- VDD15 P1

- VCCSA1 M27
- VCCSA2 M26
- VCCSA3 L26
- VCCSA4 J26
- VCCSA5 J25
- VCCSA6 J24
- VCCSA7 H25
- VCCSA8 H25

- VCCPL1 B6
- VCCPL2 A6
- VCCPL3 A2

- VCCSA\_VID[0] C22
- VCCSA\_VID[1] C24
- VCCIO\_SEL A19

- VAXG\_SENSE AK35
- VSSAXG\_SENSE AK34

- SM\_VREF AL1
- SA\_DIMM\_VREFDQ B4
- SB\_DIMM\_VREFDQ D1

- VCCSA\_VID[0] C22
- VCCSA\_VID[1] C24
- VCCIO\_SEL A19

- VCCPL1 B6
- VCCPL2 A6
- VCCPL3 A2

- VCCSA\_VID[0] C22
- VCCSA\_VID[1] C24
- VCCIO\_SEL A19

- VAXG\_SENSE AK35
- VSSAXG\_SENSE AK34

- SM\_VREF AL1
- SA\_DIMM\_VREFDQ B4
- SB\_DIMM\_VREFDQ D1

- VCCSA1 M27
- VCCSA2 M26
- VCCSA3 L26
- VCCSA4 J26
- VCCSA5 J25
- VCCSA6 J24
- VCCSA7 H25
- VCCSA8 H25

- VCCPL1 B6
- VCCPL2 A6
- VCCPL3 A2

- VCCSA\_VID[0] C22
- VCCSA\_VID[1] C24
- VCCIO\_SEL A19

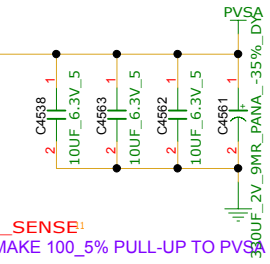
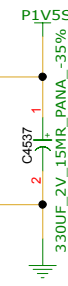
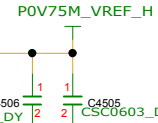
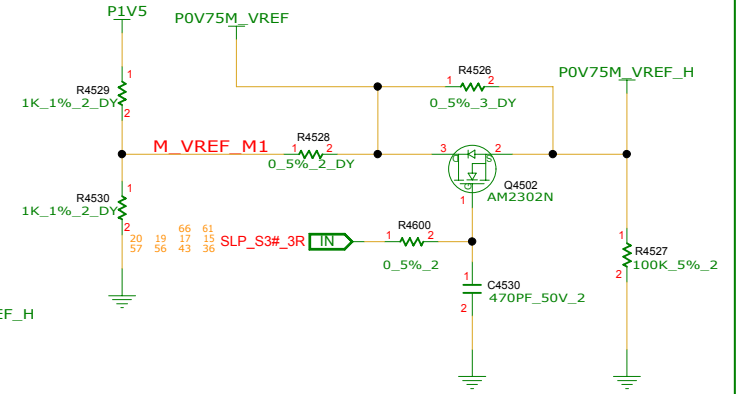

VCCSA\_SENSE WITH 55 OHM IMPEDANCE AND MAKE 100\_5% PULL-UP TO PVSA, NO INSTALL

VCCSA\_VID0<sup>11</sup>  
VCCSA\_VID1<sup>11</sup>  
VCCIO\_SEL<sup>9</sup>

<b>INVENTEC</b>			
TITLE			
MODEL PROJECT FUNCTION			
I.VY BRIDGE_5 (GRAPHICS POWER)			
DOC NUMBER			
1310xxxxx-0-0			
REV			
X01			
SIZE	CODE	DATE	SHEET
A3	CS	21-OCT-2002	27 of 77

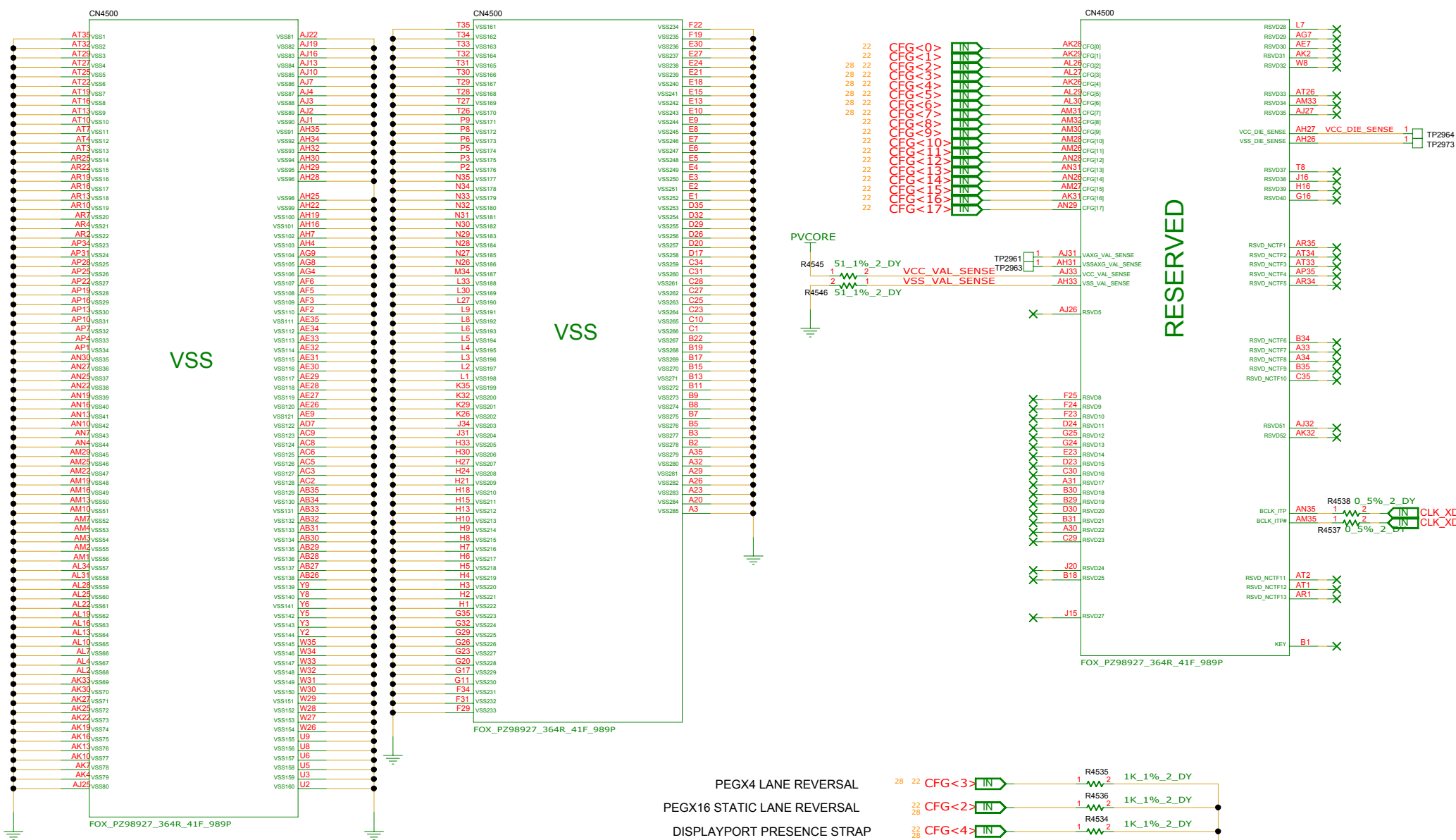

REFERENCE NUMBER:4500~4699

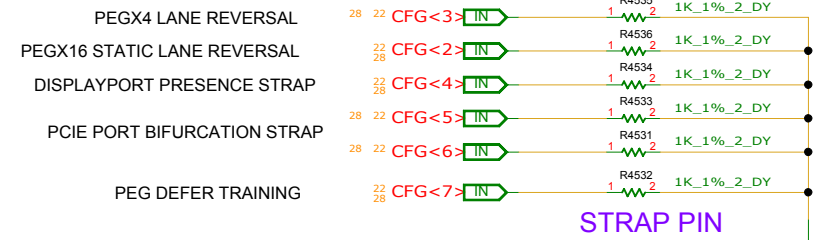

**INVENTEC**

TITLE  
 MODEL PROJECT FUNCTION  
 I7Y BRIDGE 6 (GND,RESERVED)

DOC NUMBER  
 1310xxxxx-0-0

REV  
 X01

CHANGE by XXX DATE 21-OCT-2002 SHEET 28 of 77

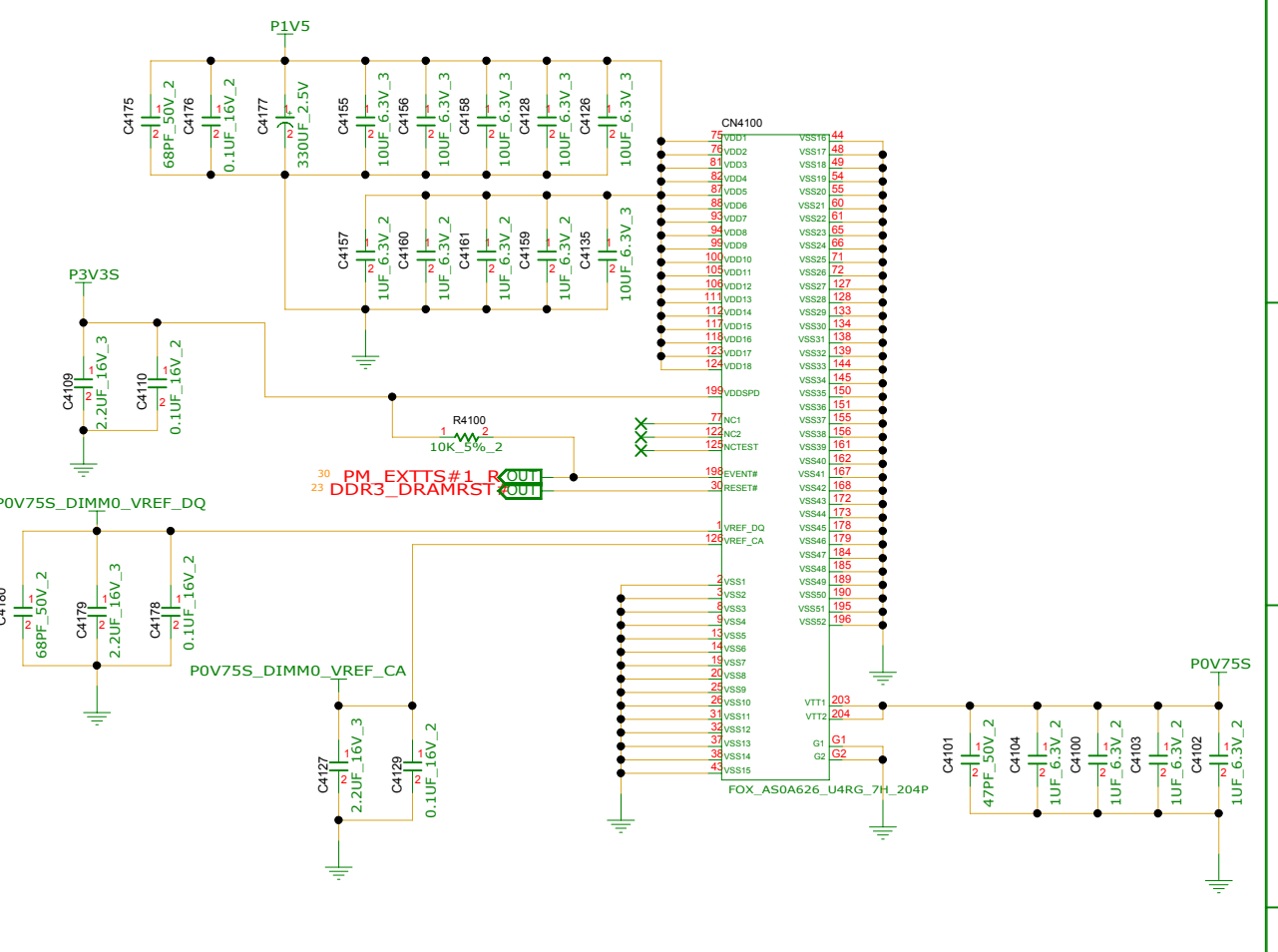
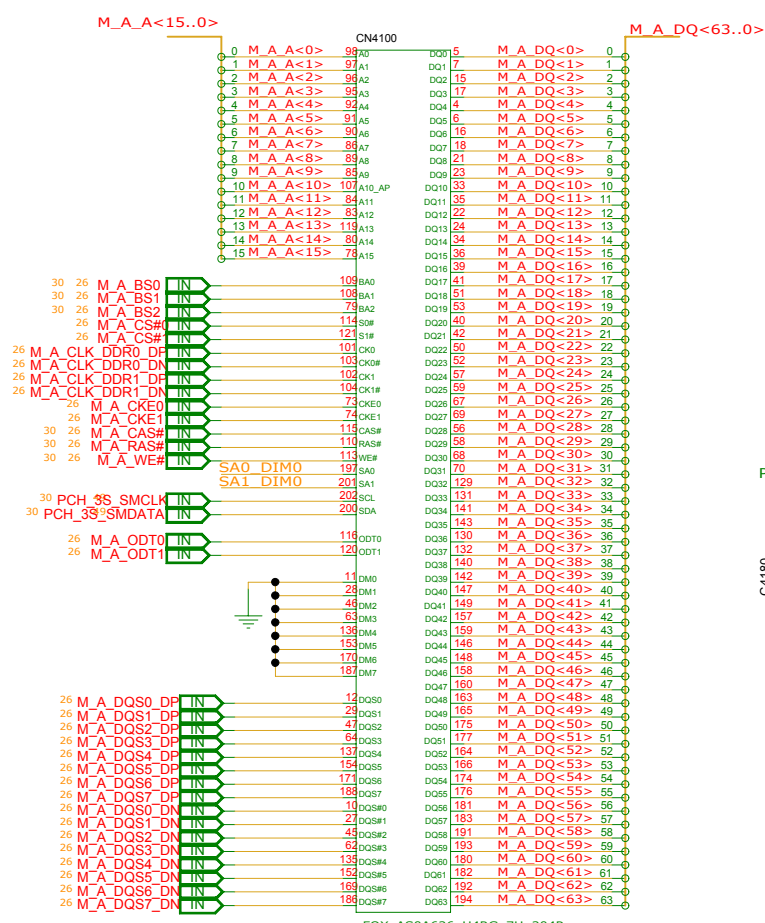

# CHANNEL A DIMM0 BOTTOM

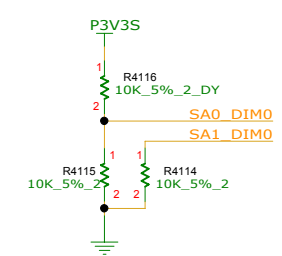

<b>INVENTEC</b>			
TITLE			
MODEL,PROJECT,FUNCTION			
Block Diagram			
SIZE	CODE	DOC NUMBER	REV
A3	CS	1310xxxxx-0-0	X01
CHANGE by		DATE	SHEET
XXX		21-OCT-2002	29 of 77

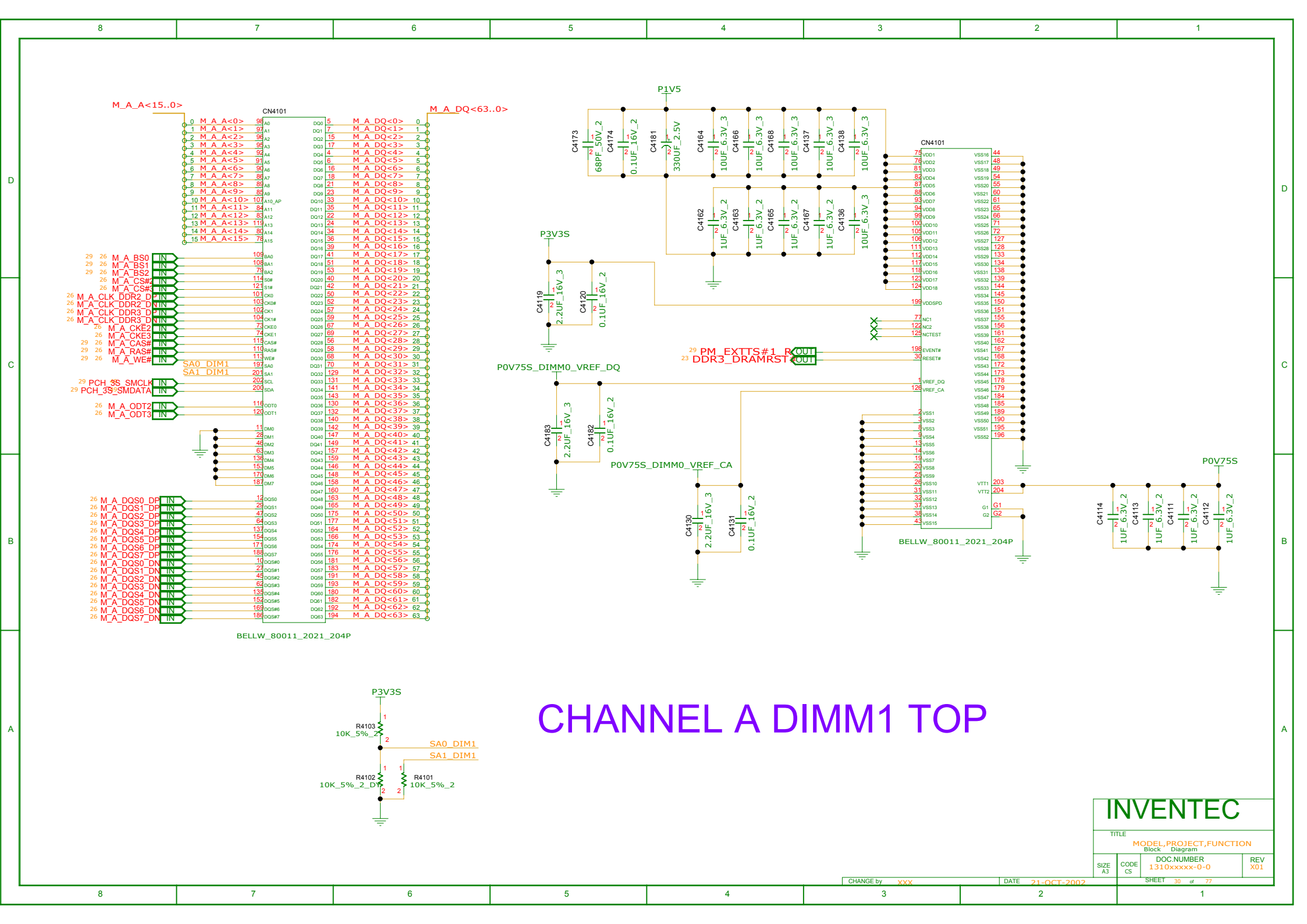

# CHANNEL A DIMM1 TOP

<b>INVENTEC</b>			
TITLE			
MODEL,PROJECT,FUNCTION			
Block Diagram			
SIZE	CODE	DOC NUMBER	REV
A3	CS	1310xxxxx-0-0	X01
CHANGE by		DATE	SHEET
XXX		21-OCT-2002	30 of 77

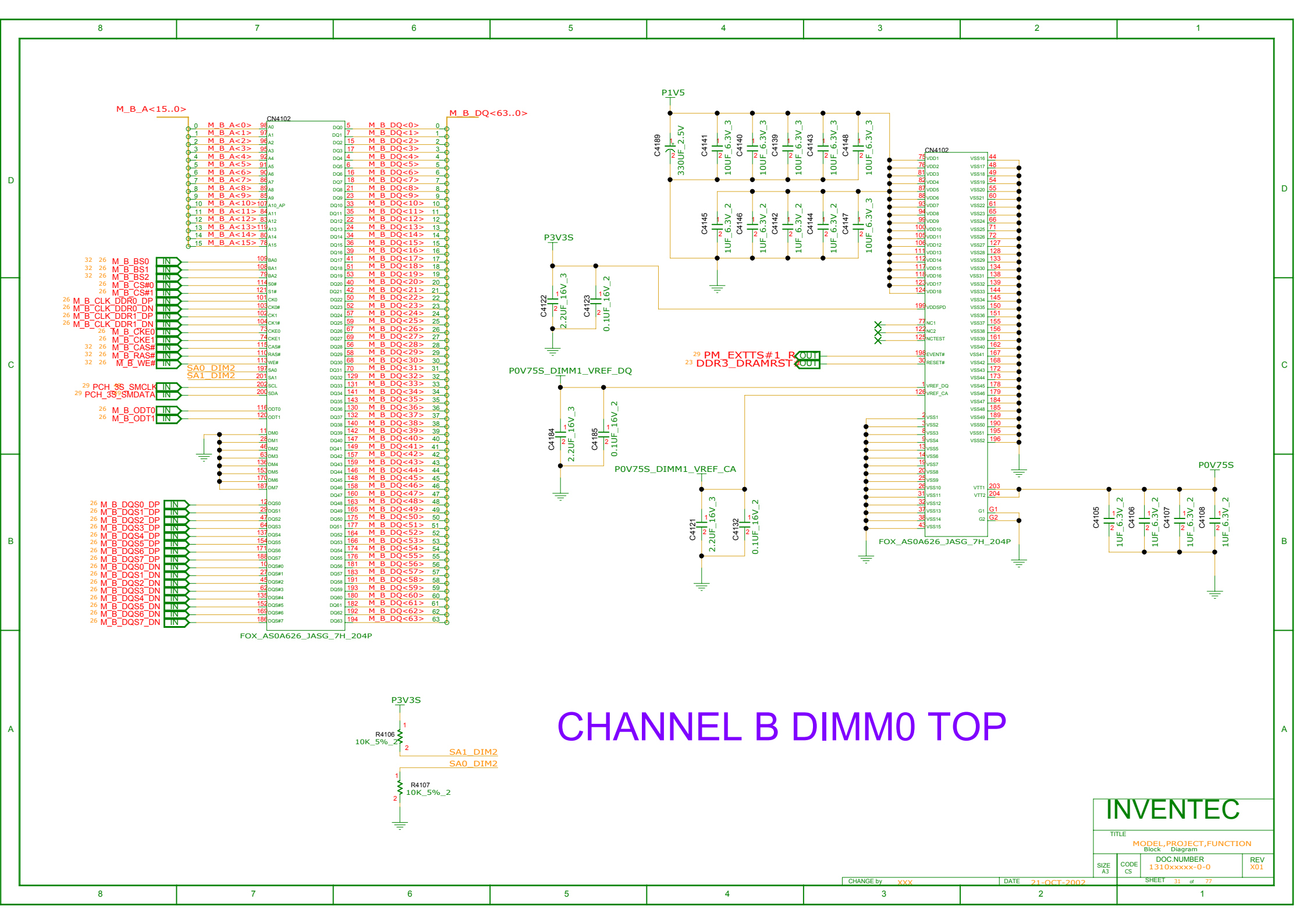

# CHANNEL B DIMM0 TOP

<b>INVENTEC</b>			
TITLE			
MODEL,PROJECT,FUNCTION Block Diagram			
SIZE A3	CODE CS	DOC NUMBER 1310xxxxx-0-0	REV X01
CHANGE by XXX		DATE 21-OCT-2002	SHEET 31 of 77

# CHANNEL B DIMM1 BOTTOM

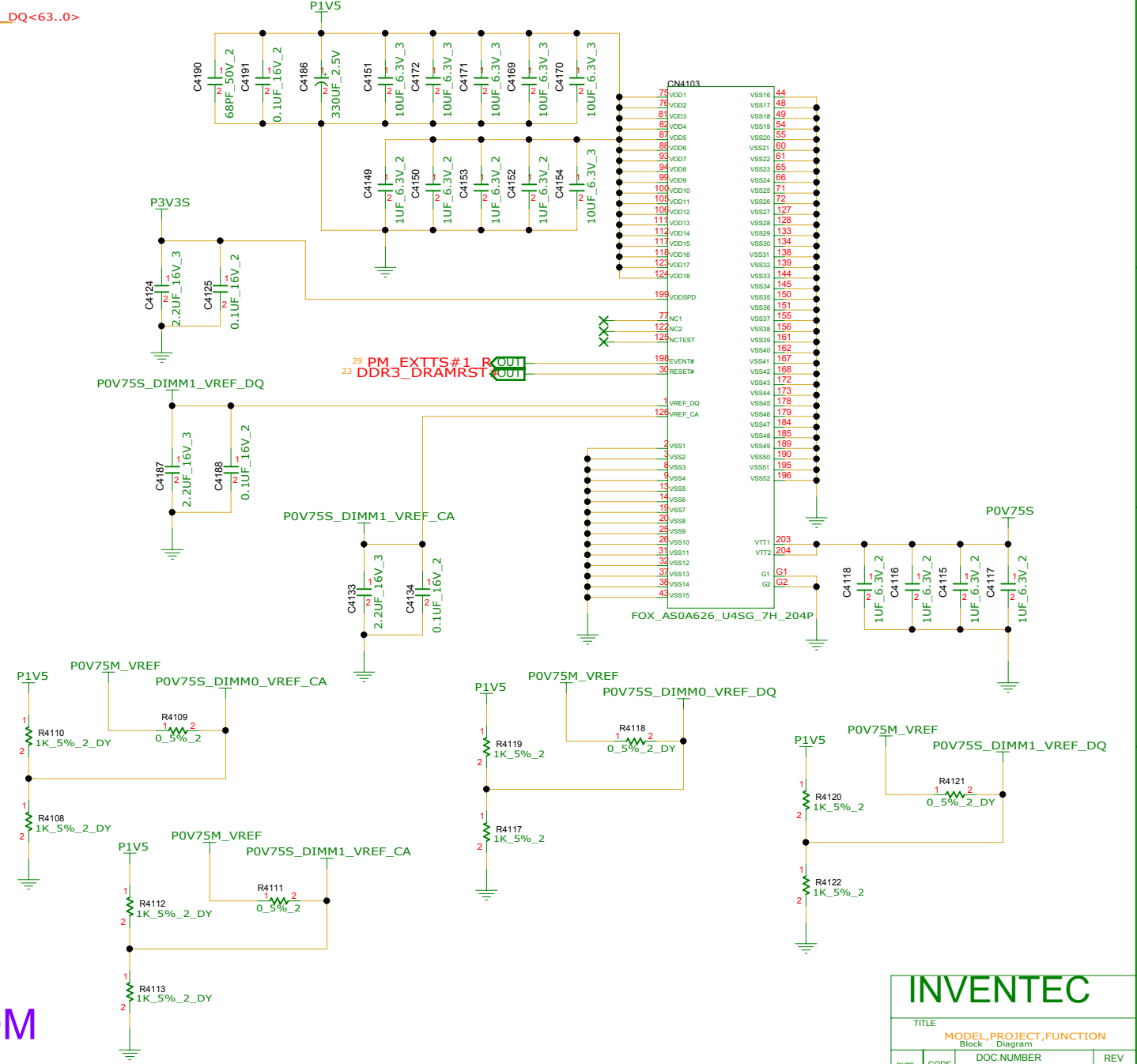
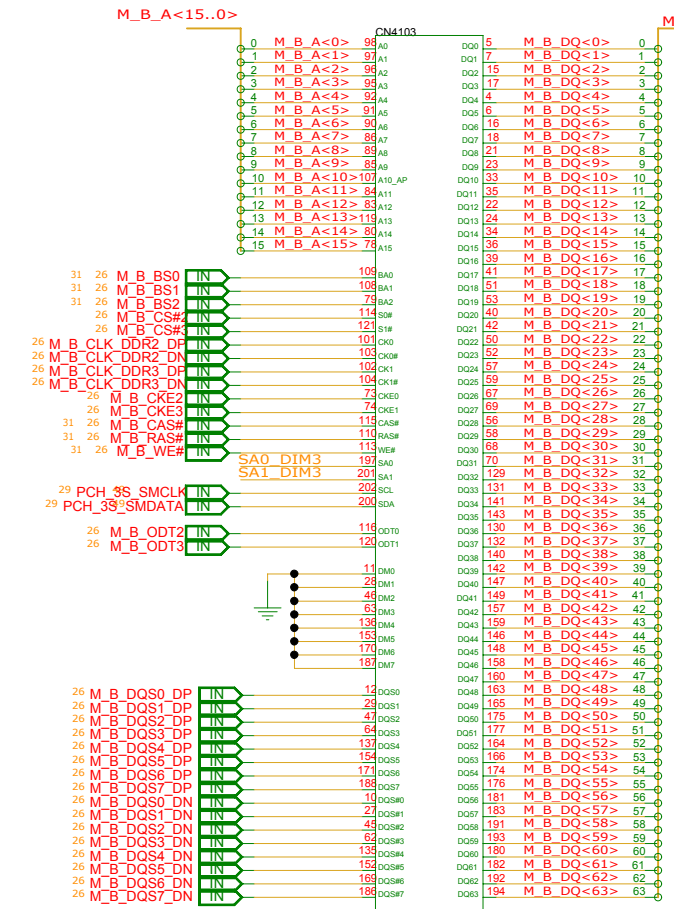

**INVENTEC**

TITLE: MODEL,PROJECT,FUNCTION  
Block Diagram

SIZE A3	CODE CS	DOC NUMBER 1310xxxxx-0-0	REV X01
---------	---------	--------------------------	---------

CHANGE by: XXX DATE: 21-OCT-2002 SHEET 32 of 77



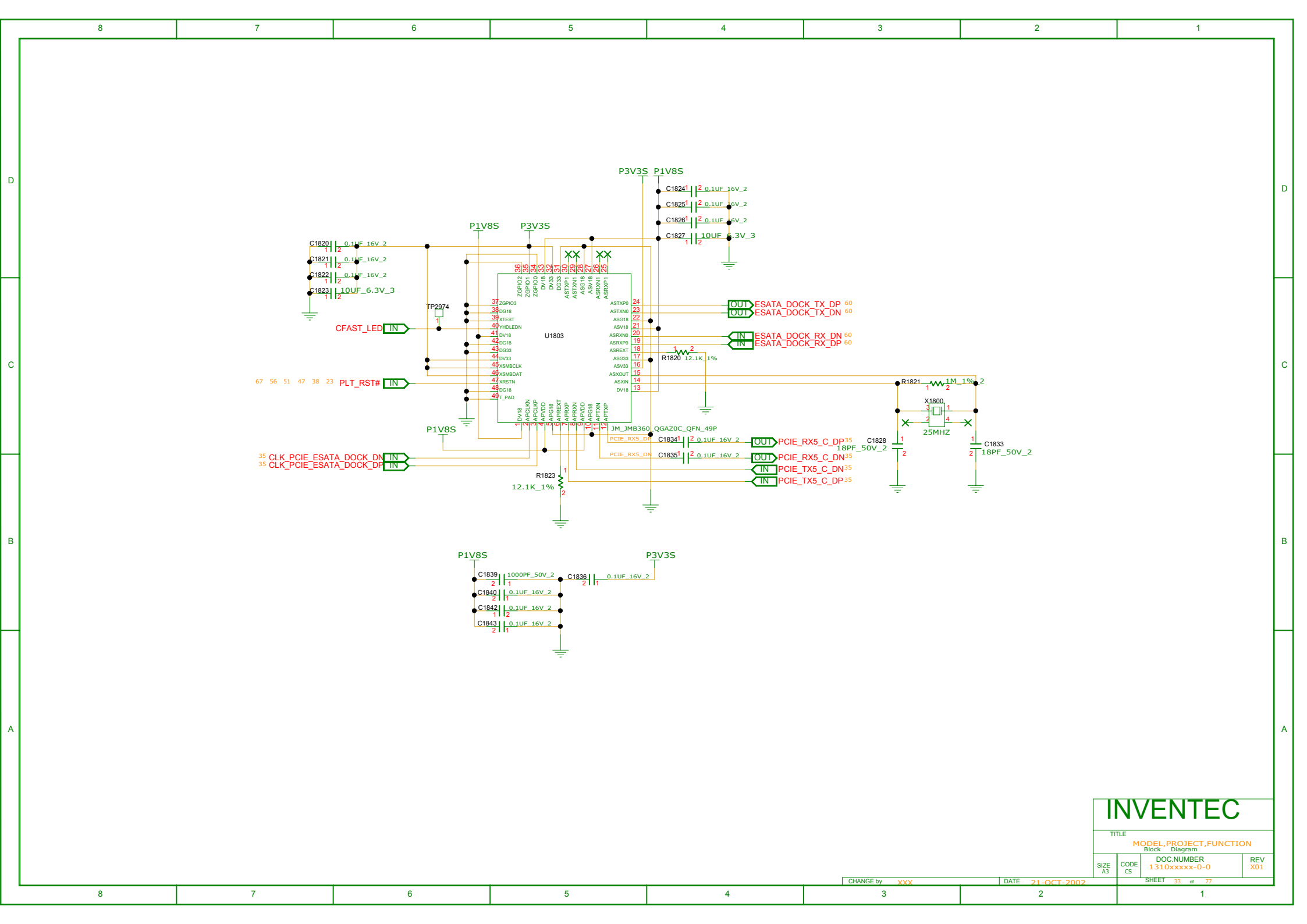

**INVENTEC**

TITLE MODEL,PROJECT,FUNCTION  
Block Diagram

SIZE A3 CODE CS DOC NUMBER 1310xxxxx-0-0 REV X01



REFERENCE NUMBER : 4700~4949

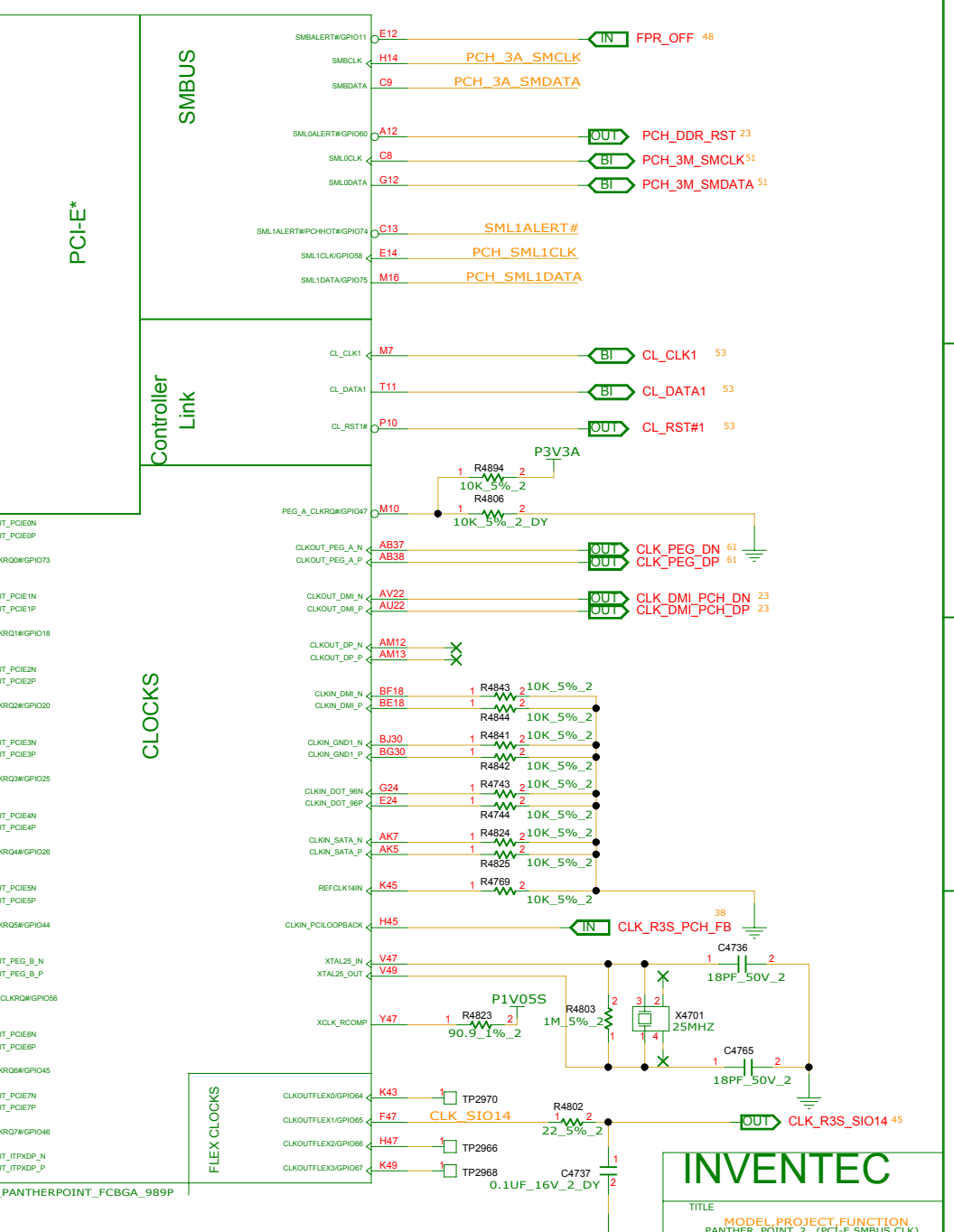
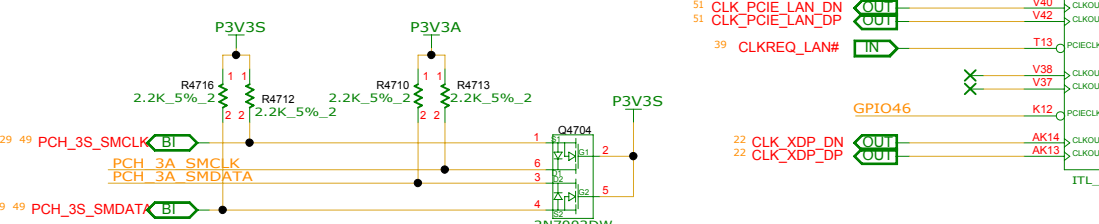
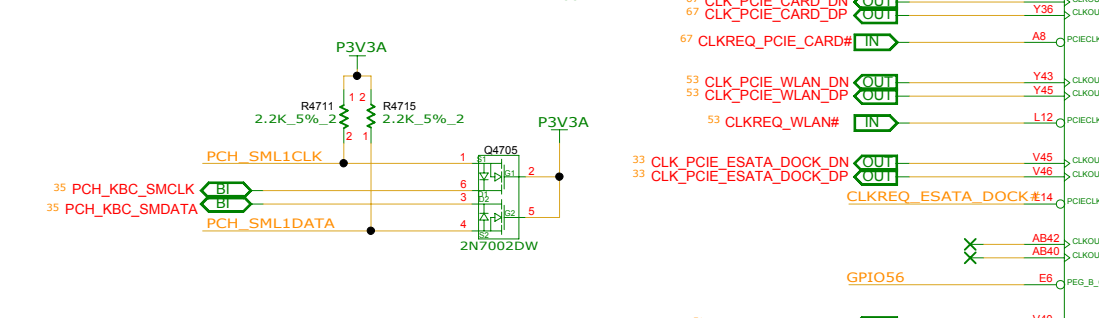
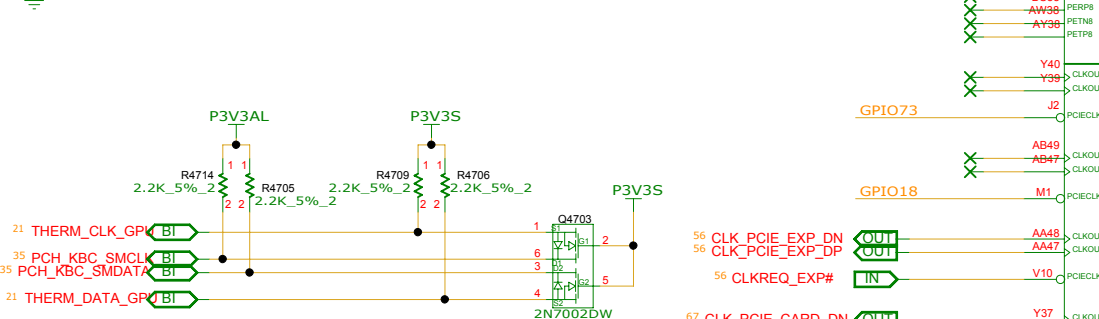
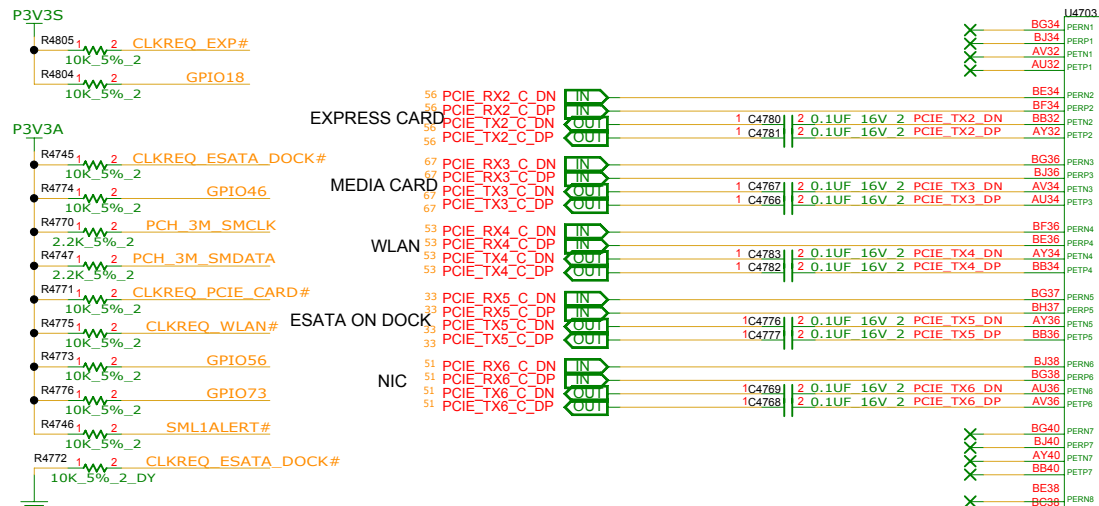

<b>INVENTEC</b>			
TITLE			
MODEL PROJECT FUNCTION			
PANTHER POINT 2 (PCI-E, SMBUS, CLK)			
SIZE	CODE	DOC NUMBER	REV
A3	CS	1310xxxxx-0-0	X01
CHANGE by XXX			DATE 21-OCT-2002
			SHEET 35 of 77

REFERENCE NUMBER : 4700~4949

NOTE:

- 1.SLP\_SUS AND SUSACK# ARE NC IF DSW IS NOT SUPPORTED
- 2.DPWROK SHOULD CONNECT TO RSMRST# IF DSW NOT SUPPORTED
- 3.PCH\_DPWROK PULL UP TO P3V3S ENABLES DSW WUPPORT. NO INSTALL R4752 TO DISABLE DSW

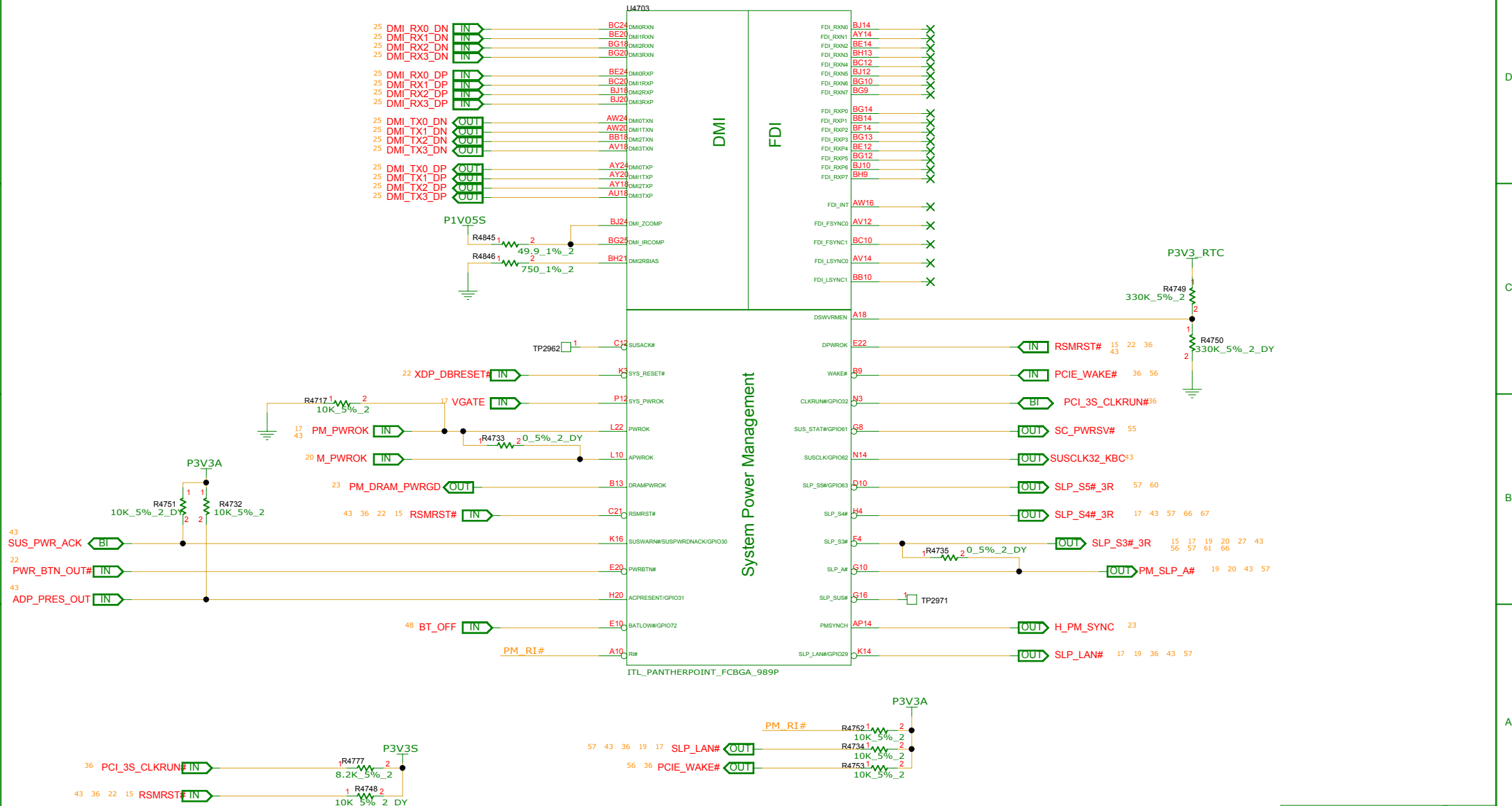

<b>INVENTEC</b>			
TITLE			
MODEL PROJECT FUNCTION PANTHER_POINT_3 (DMI,FDI,GPIO)			
SIZE A3		DOC NUMBER 1310xxxxx-0-0	
CODE CS		REV X01	
CHANGE by XXX		DATE 21-OCT-2002	
SHEET 36 of 77			

REFERENCE NUMER : 4700~4949

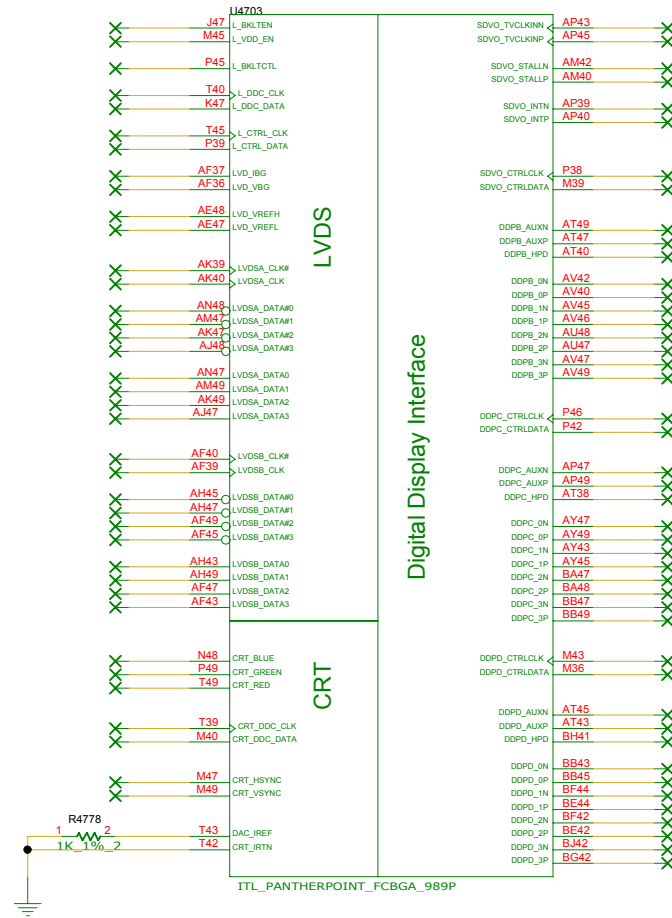

**INVENTEC**

TITLE  
MODEL PROJECT FUNCTION  
PANTHER POINT\_4 (LVDS,DDI)

DOC NUMBER  
1310xxxxx-0-0

REV  
X01

REFERENCE NUMER : 4700~4949

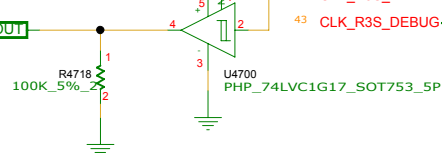
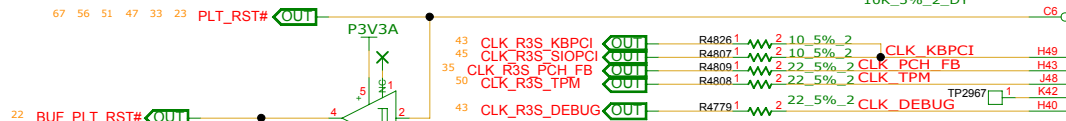
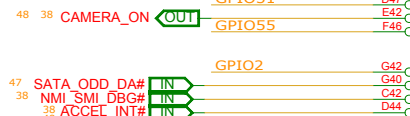
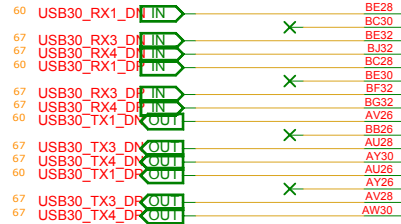
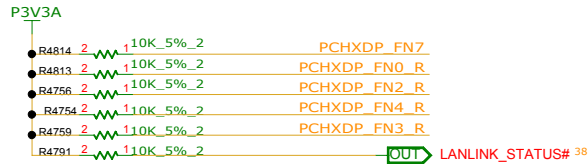
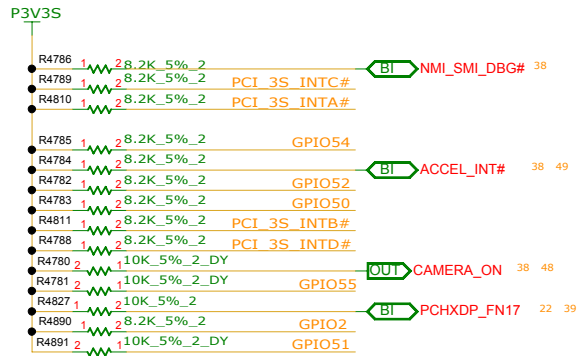

U4703

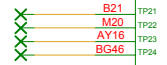
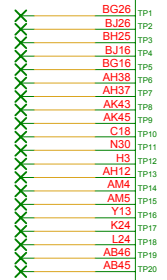

RSVD

PCI

NVRAM

USB

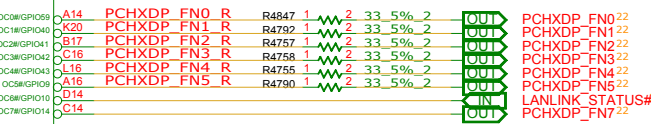
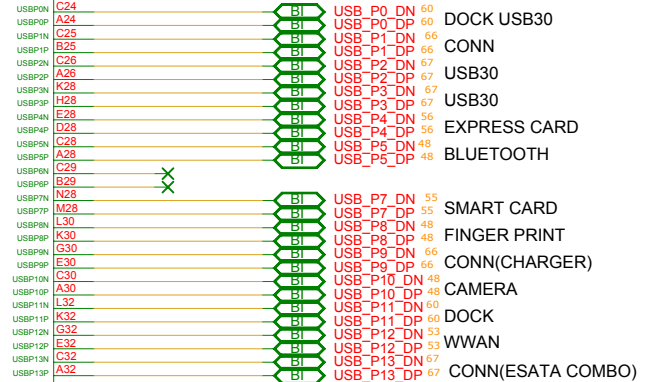
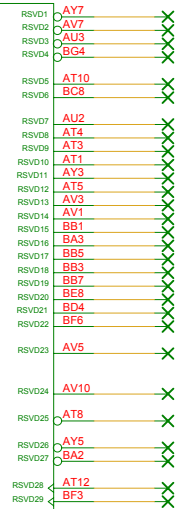

ITL\_PANTHERPOINT\_FCBGA\_989P

**INVENTEC**

TITLE

MODEL PROJECT FUNCTION  
PANTHER\_POINT\_5 (PCI,USB,NVRAM)

SIZE A3	CODE CS	DOC NUMBER 1310xxxxx-0-0	REV X01
---------	---------	--------------------------	---------

CHANGE by XXX DATE 21-OCT-2002 SHEET 38 of 77

REFERENCE NUMER : 4700~4949

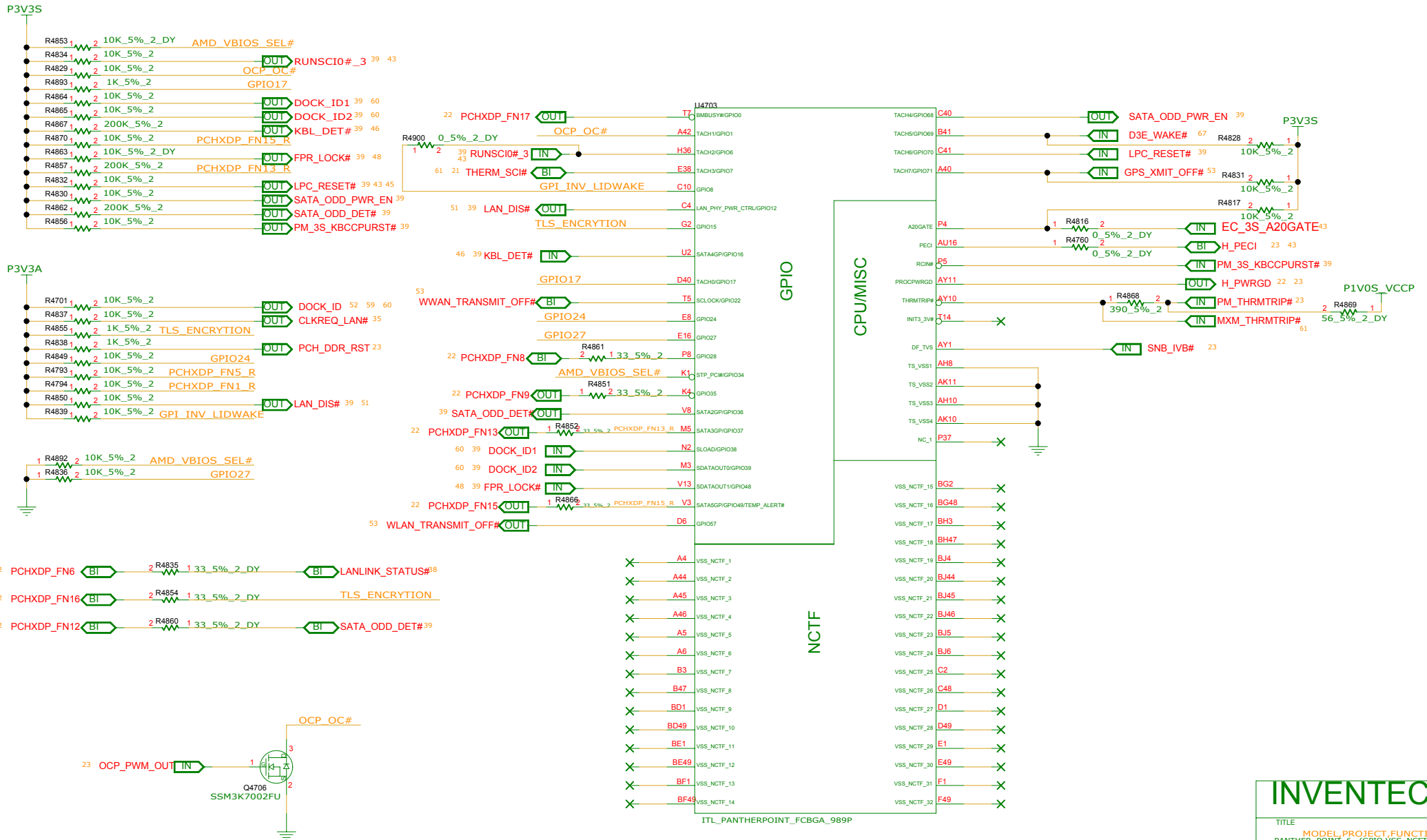

<b>INVENTEC</b>			
TITLE MODEL PROJECT FUNCTION			
PANTHER_POINT_9 (GPIO,VSS_NCTF,RSVD)			
SIZE A3	CODE CS	DOC NUMBER 1310xxxxx-0-0	REV X01
CHANGE by XXX		DATE 21-OCT-2002	SHEET 39 of 77

REFERENCE NUMER : 4700~4949

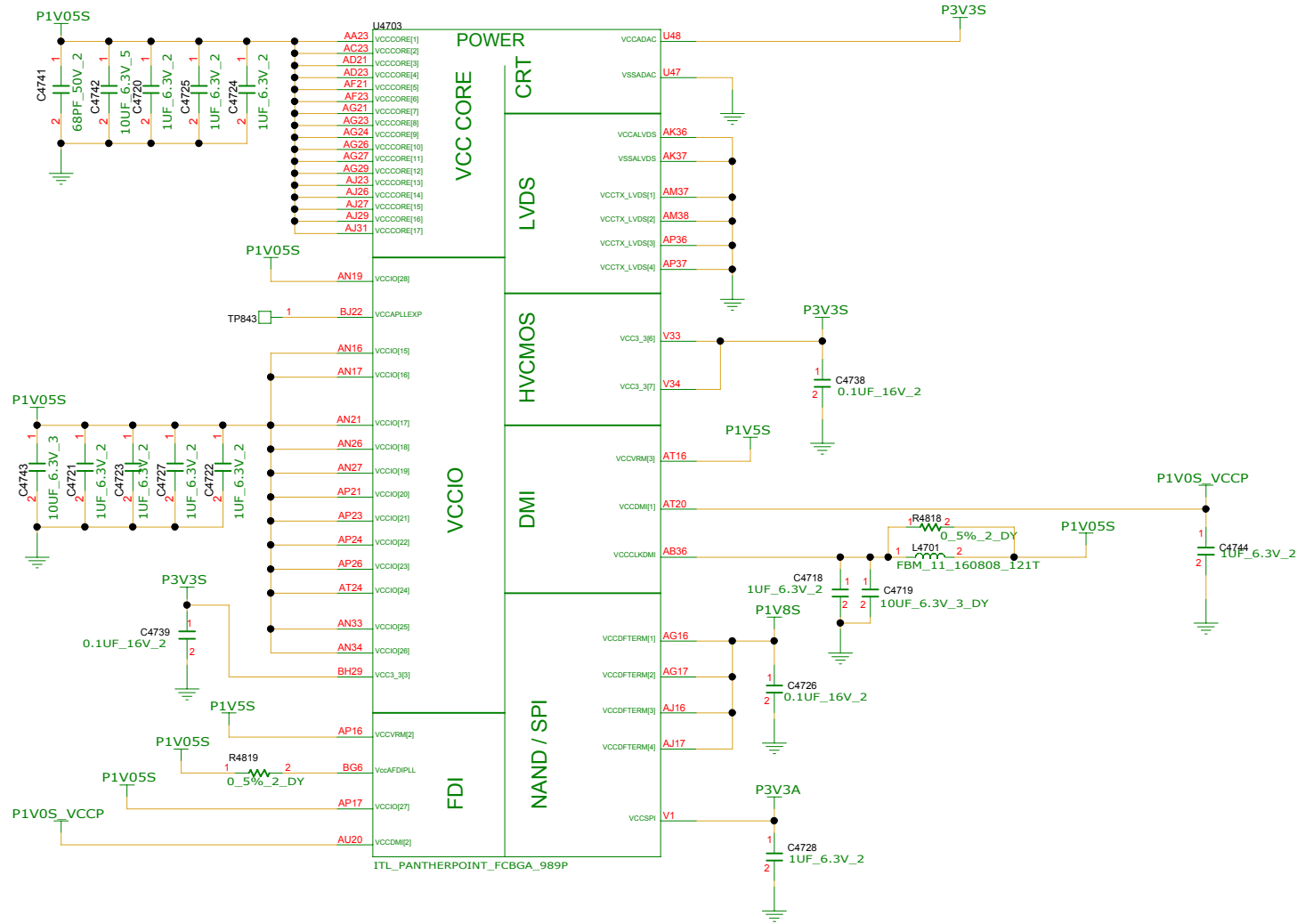

**INVENTEC**

TITLE			
MODEL PROJECT FUNCTION PANTHER POINT 2 (POWER)			
SIZE A3	CODE CS	DOC NUMBER 1310xxxxx-0-0	REV X01
CHANGE by XXX		DATE 21-OCT-2002	SHEET 40 of 77



REFERENCE NUMER : 4700~4949

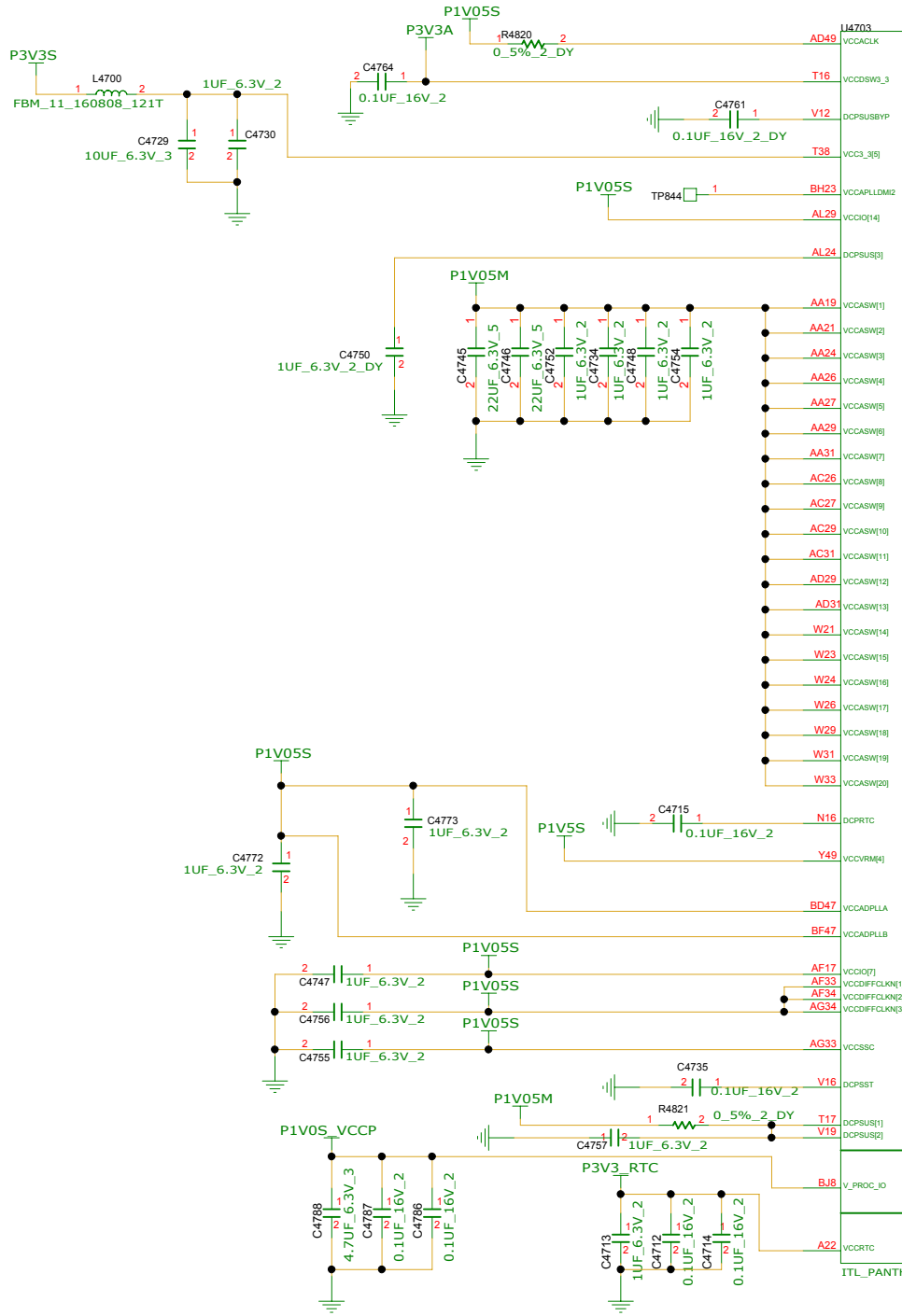

POWER

USB

Clock and Miscellaneous

PCI/GPIO/LPC

SATA

MISC

RTC CPU

HDA

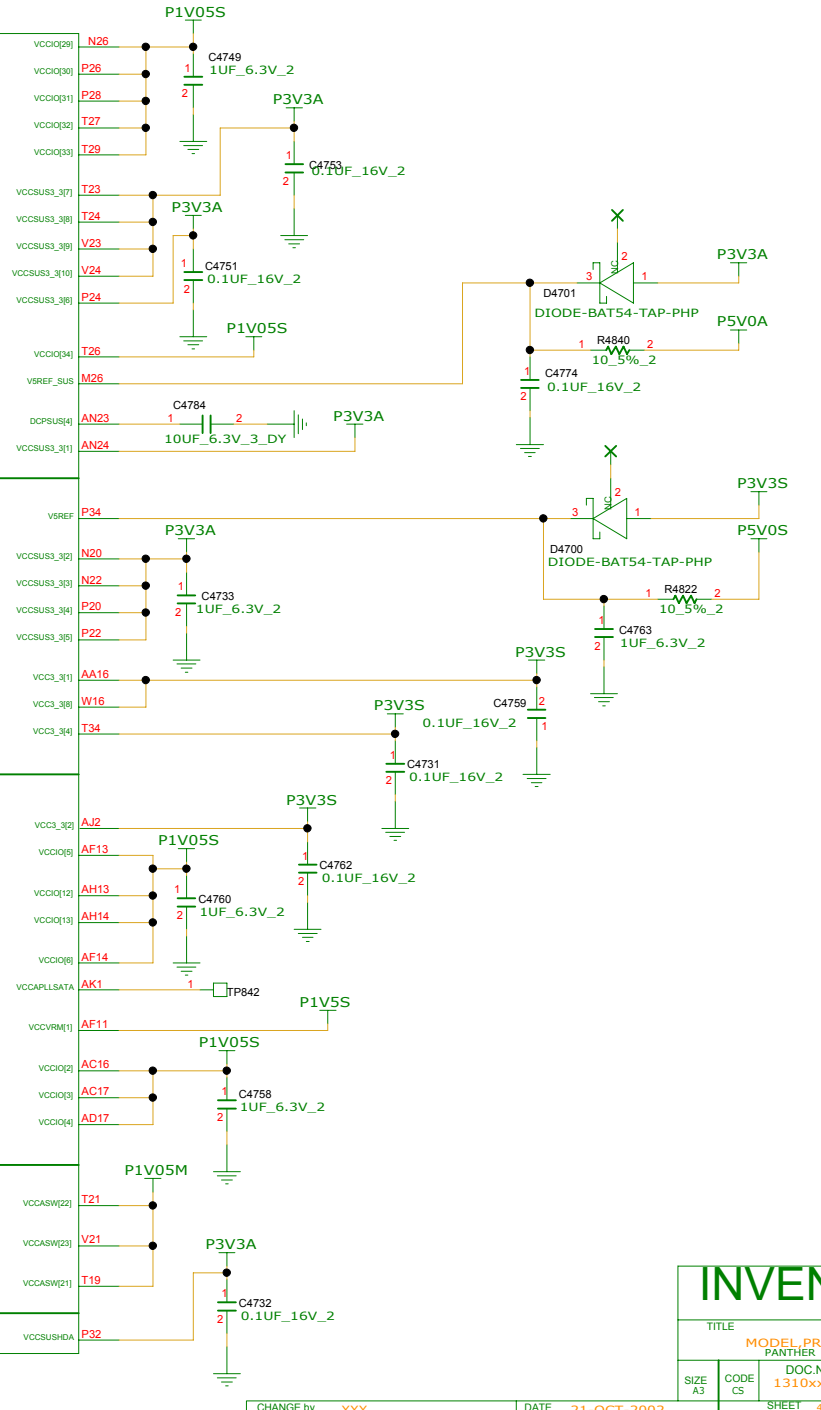

<b>INVENTEC</b>			
TITLE MODEL PROJECT FUNCTION PANTHER POINT 3 (POWER)			
SIZE A3	CODE CS	DOC NUMBER 1310xxxxx-0-0	REV X01
CHANGE by XXX		DATE 21-OCT-2002	SHEET 41 of 77

ITL\_PANTHERPOINT\_FCBGA\_989P

REFERENCE NUMBER : 4700~4949

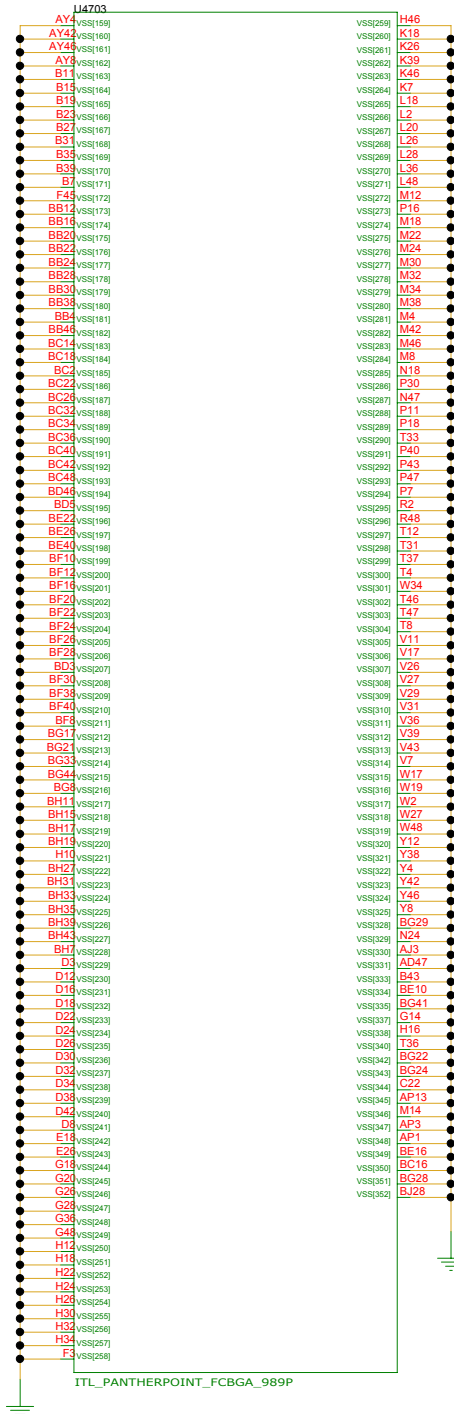
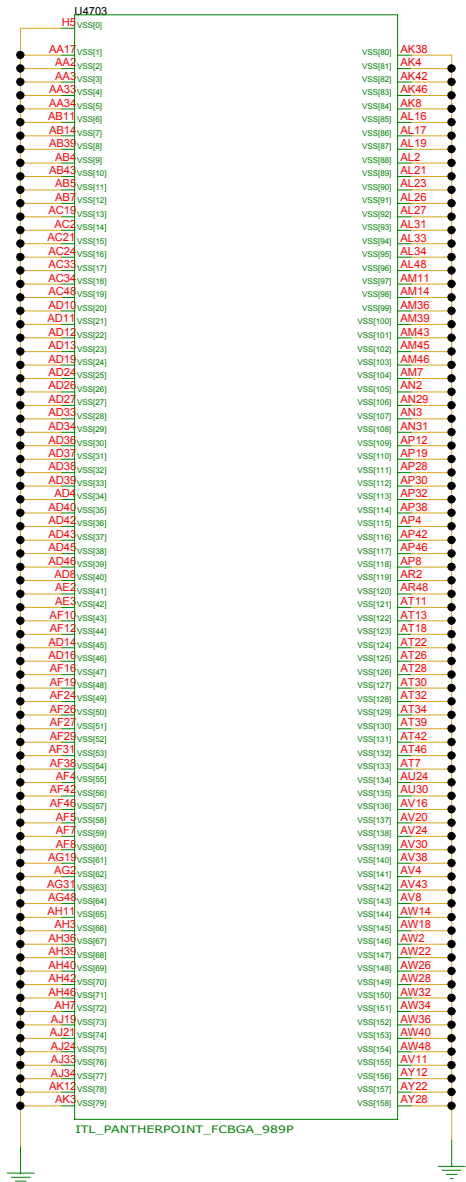

**INVENTEC**

TITLE  
 MODEL PROJECT FUNCTION  
 PANTHER POINT 9 (GND)

SIZE A3	CODE CS	DOC NUMBER 1310xxxxx-0-0	REV X01
------------	------------	-----------------------------	------------

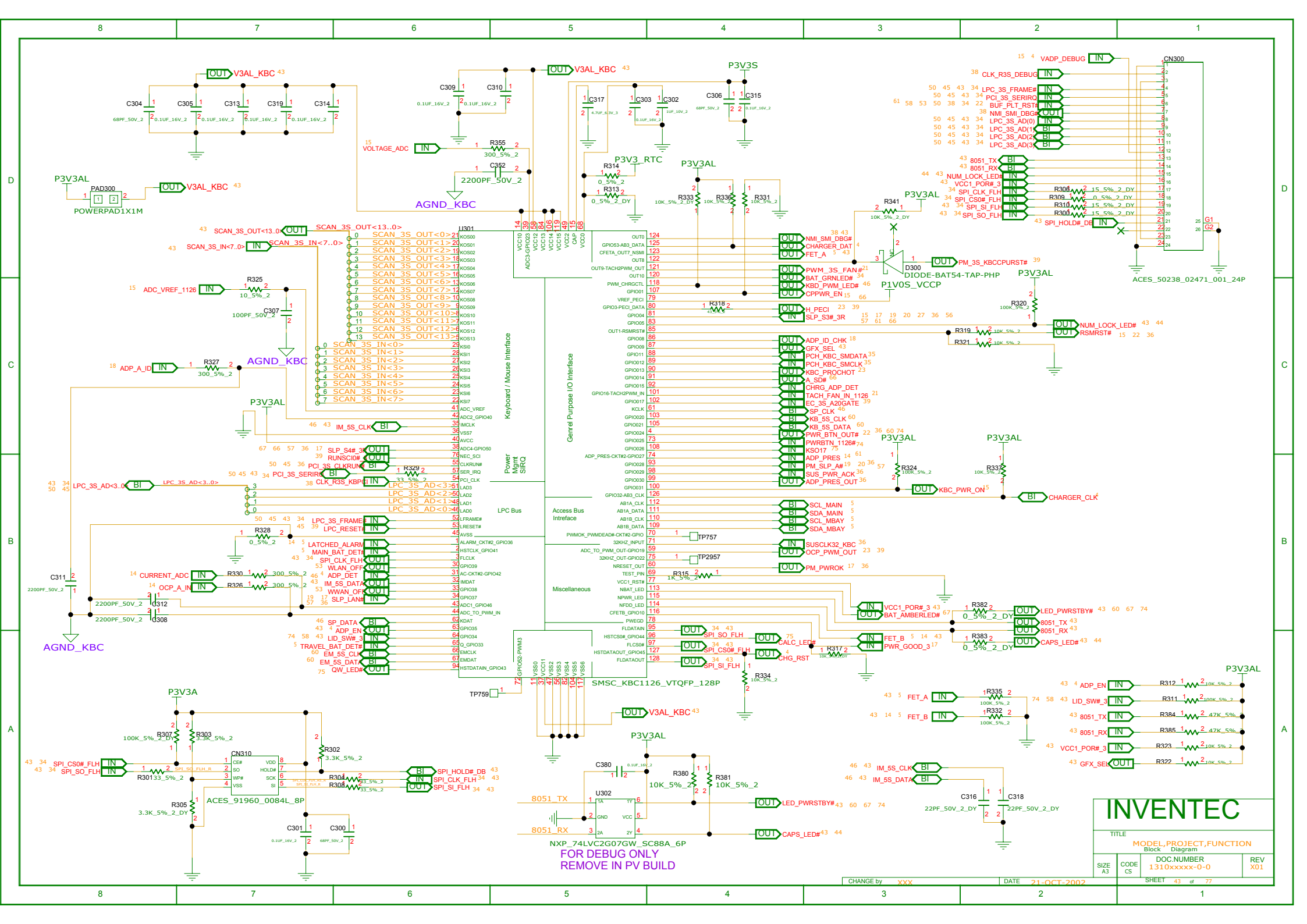

**INVENTEC**

TITLE			
MODEL,PROJECT,FUNCTION Block Diagram			
SIZE A3	CODE CS	DOC NUMBER 1310xxxxx-0-0	REV X01
CHANGE by XXX		DATE 21-OCT-2002	SHEET 43 of 77

**FOR DEBUG ONLY  
REMOVE IN PV BUILD**

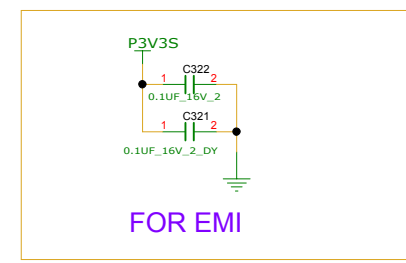
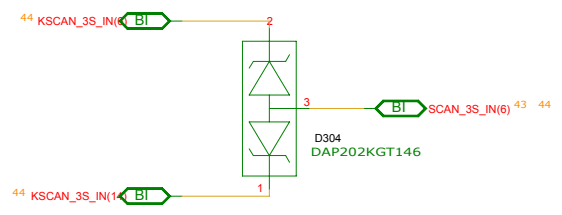
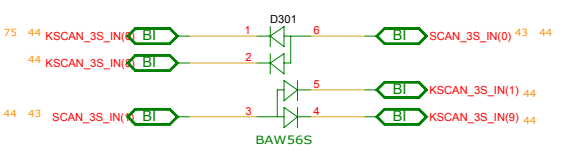
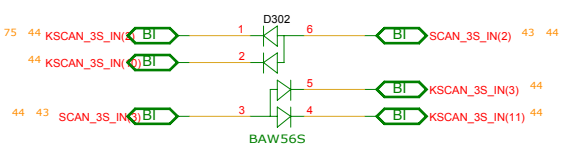
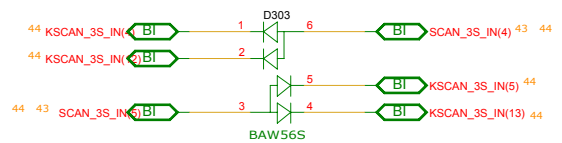
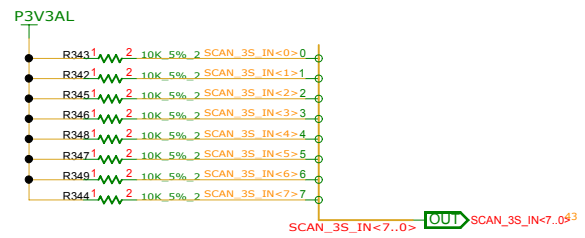
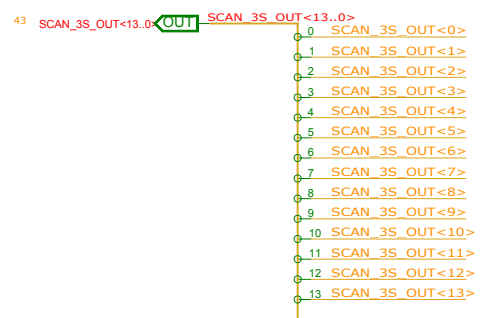
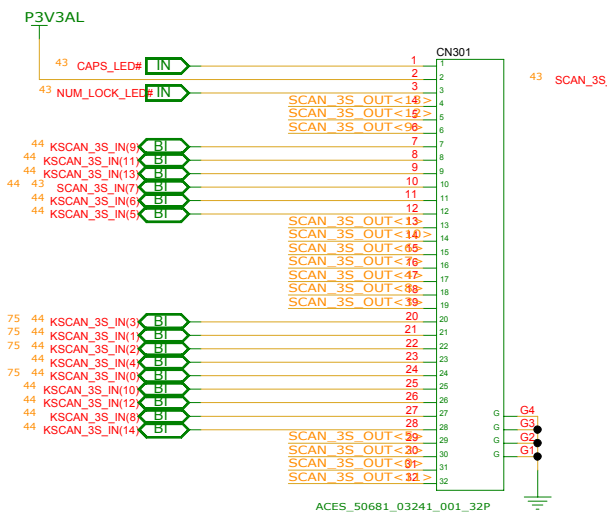

<b>INVENTEC</b>			
TITLE Block Diagram			
MODEL,PROJECT,FUNCTION			
SIZE A3	CODE CS	DOC NUMBER 1310xxxxx-0-0	REV X01
CHANGE by XXX		DATE 21-OCT-2002	SHEET 44 of 77

# SUPER I/O

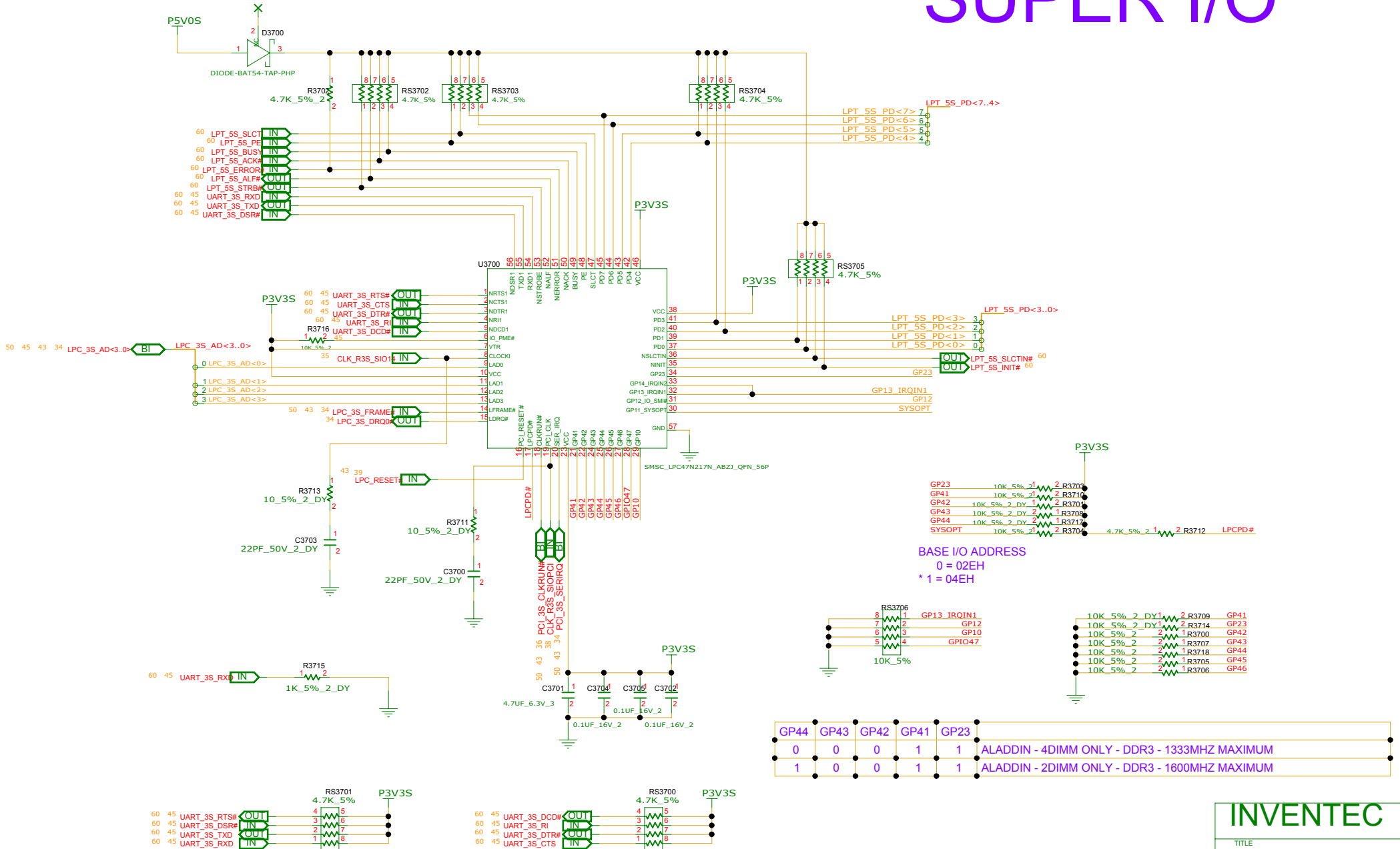

BASE I/O ADDRESS  
 0 = 02EH  
 \* 1 = 04EH

GP44	GP43	GP42	GP41	GP23	
0	0	0	1	1	ALADDIN - 4DIMM ONLY - DDR3 - 1333MHZ MAXIMUM
1	0	0	1	1	ALADDIN - 2DIMM ONLY - DDR3 - 1600MHZ MAXIMUM

**INVENTEC**

TITLE: MODEL,PROJECT,FUNCTION  
 Block Diagram

SIZE A3	CODE CS	DOC NUMBER 1310xxxxx-0-0	REV X01
---------	---------	-----------------------------	---------

CHANGE by: XXX DATE: 21-OCT-2002 SHEET 45 of 77

# KEYBOARD\_LIGHT\_CNTR

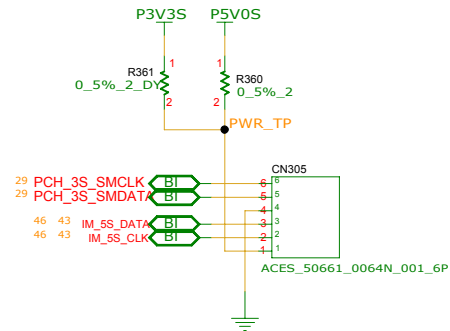
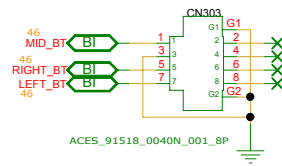
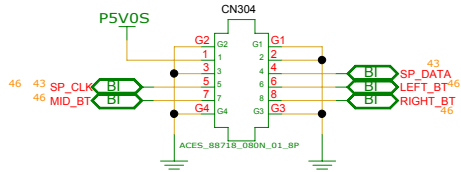
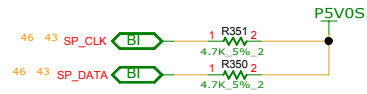
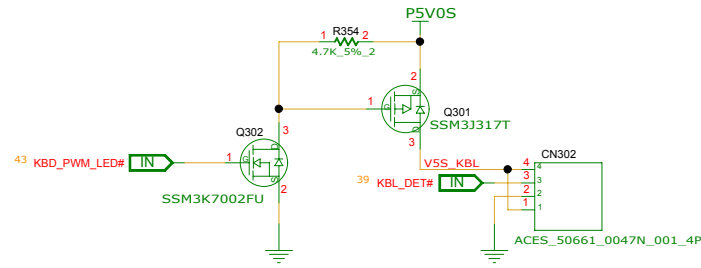

# STICK POINT

# TOUCH PAD

**INVENTEC**

TITLE			
MODEL,PROJECT,FUNCTION Block Diagram			
SIZE A3	CODE CS	DOC NUMBER 1310xxxxx-0-0	REV X01
SHEET 46 of 77			

# SATA HDD 0

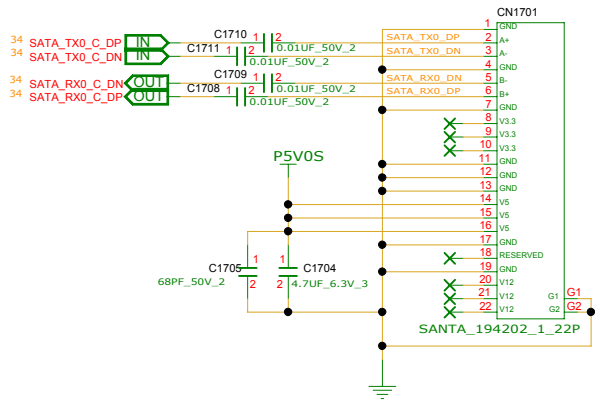

# SATA HDD 1

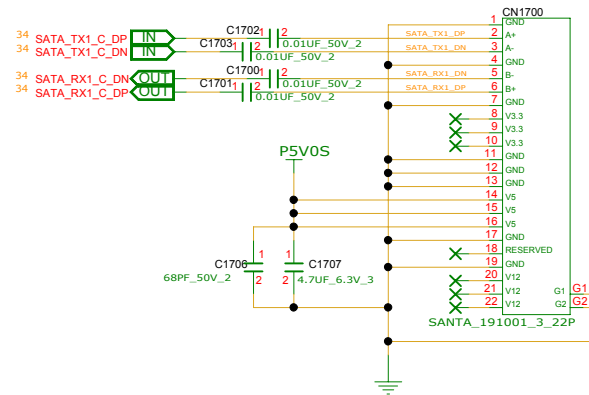

# SATA ODD

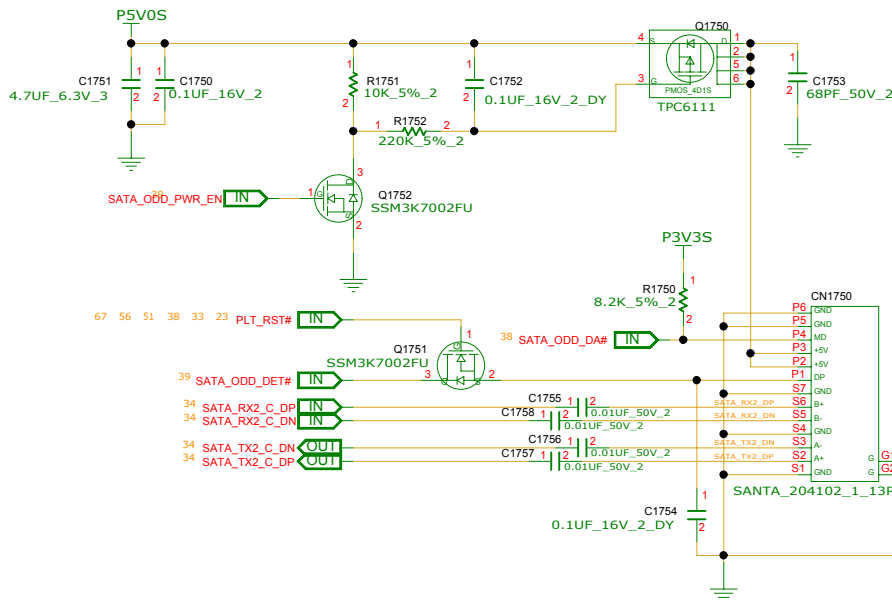

**INVENTEC**

TITLE			
MODEL,PROJECT,FUNCTION Block Diagram			
SIZE A3	CODE CS	DOC NUMBER 1310xxxxx-0-0	REV X01
SHEET 47 of 77			

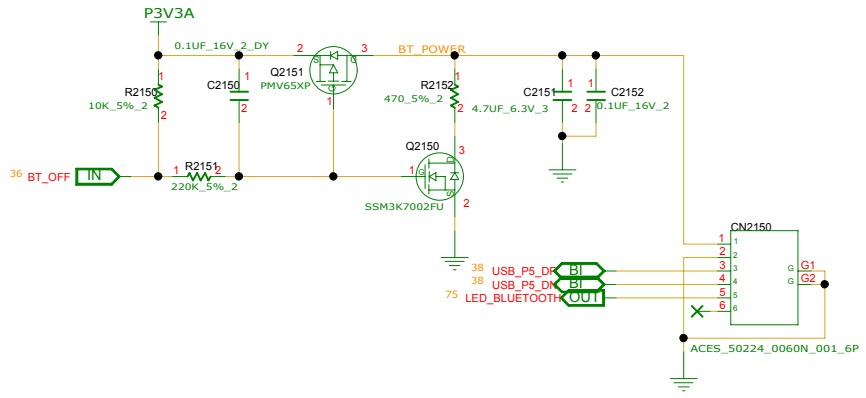

# BLUETOOTH

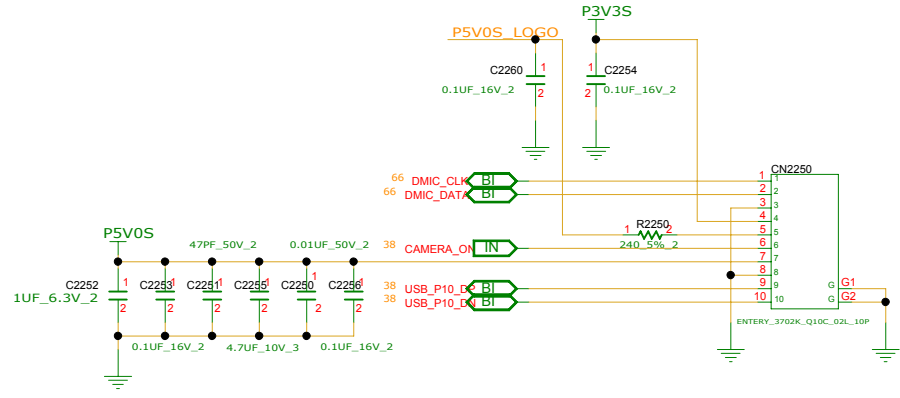

# CAMERA

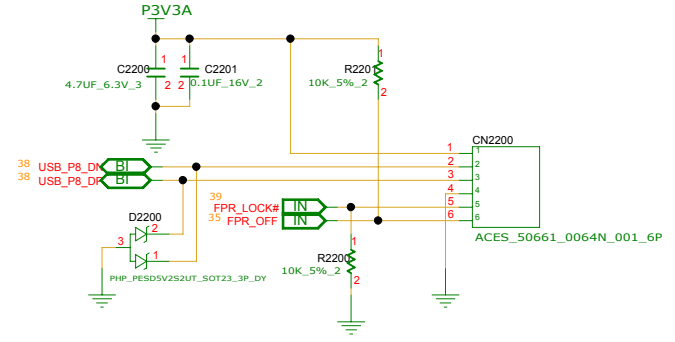

# FINGER PRINTER

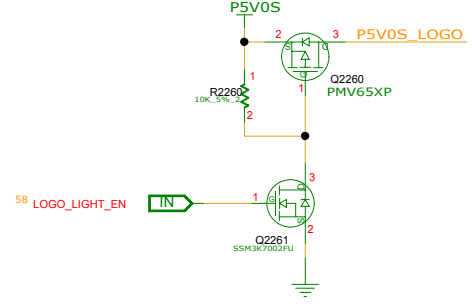

**INVENTEC**

TITLE: MODEL, PROJECT, FUNCTION  
Block Diagram

SIZE A3	CODE CS	DOC NUMBER 1310xxxx-0-0	REV X01
------------	------------	----------------------------	------------

CHANGE by: XXX DATE: 21-OCT-2002 SHEET 48 of 77



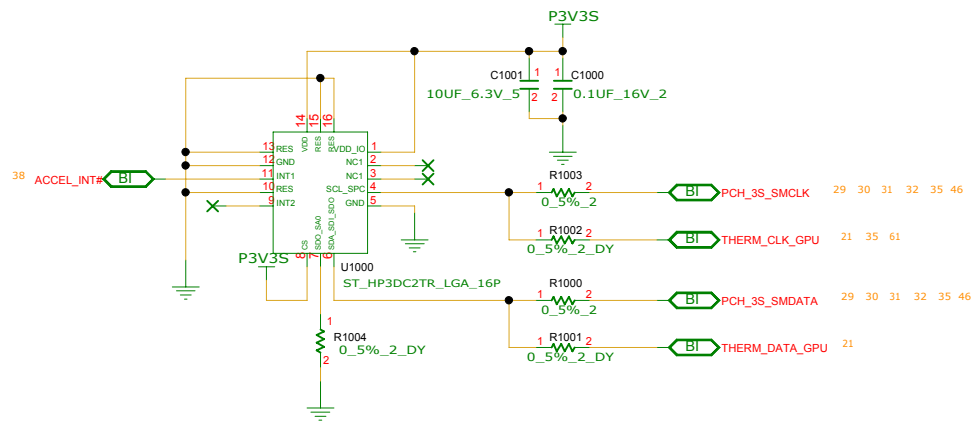

# ACCELEROMETOR

<b>INVENTEC</b>			
TITLE MODEL,PROJECT,FUNCTION Block Diagram			
SIZE A3	CODE CS	DOC NUMBER 1310xxxxx-0-0	REV X01
CHANGE by XXX		DATE 21-OCT-2002	SHEET 49 of 77

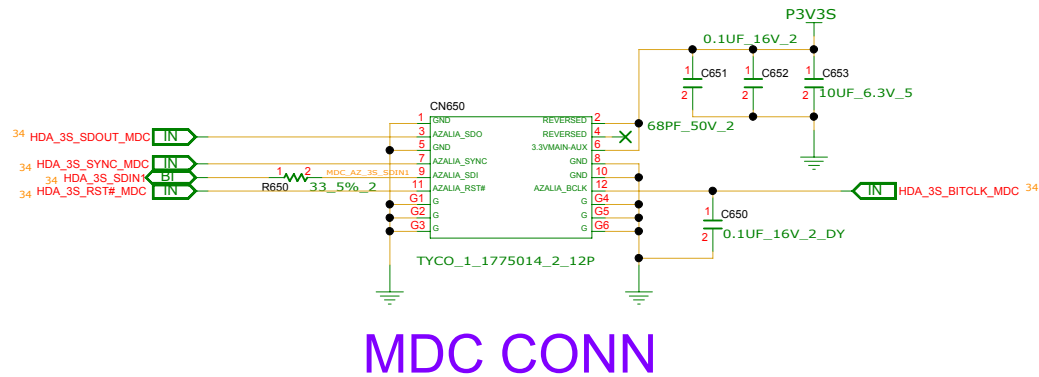
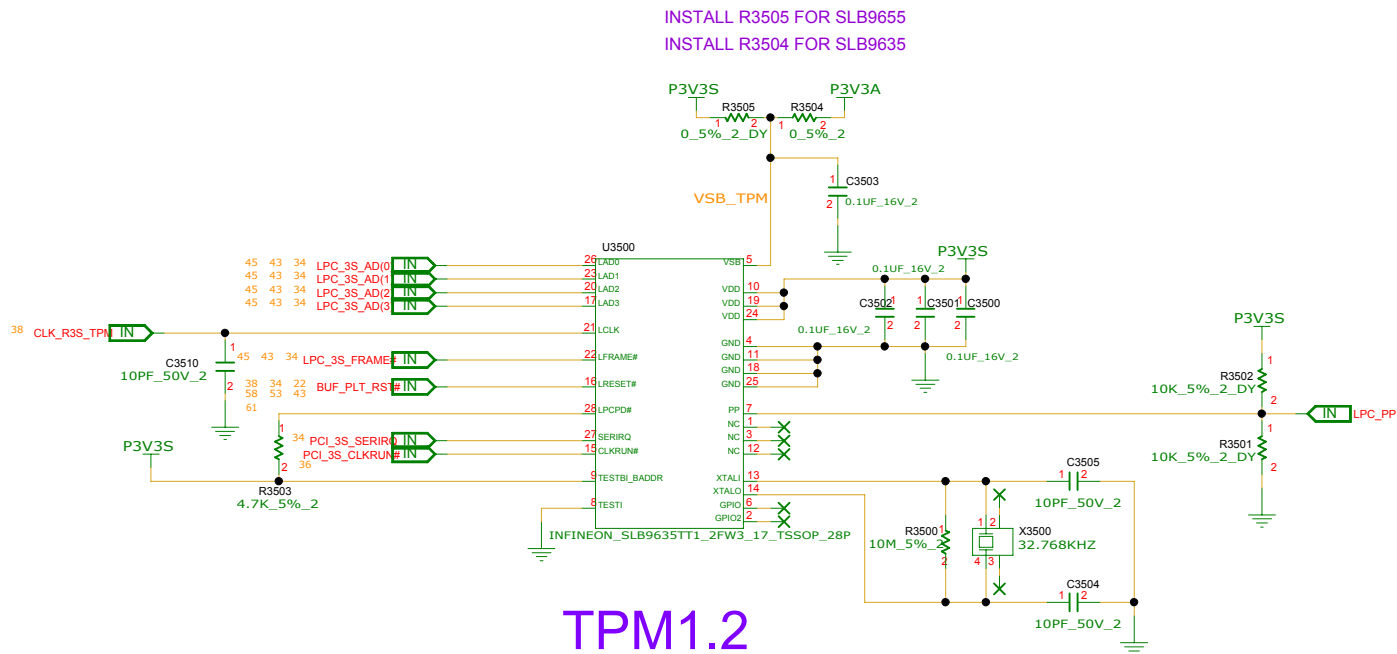

<b>INVENTEC</b>			
TITLE MODEL,PROJECT,FUNCTION Block Diagram			
SIZE A3	CODE CS	DOC NUMBER 1310xxxxx-0-0	REV X01
CHANGE by XXX		DATE 21-OCT-2002	SHEET 50 of 77

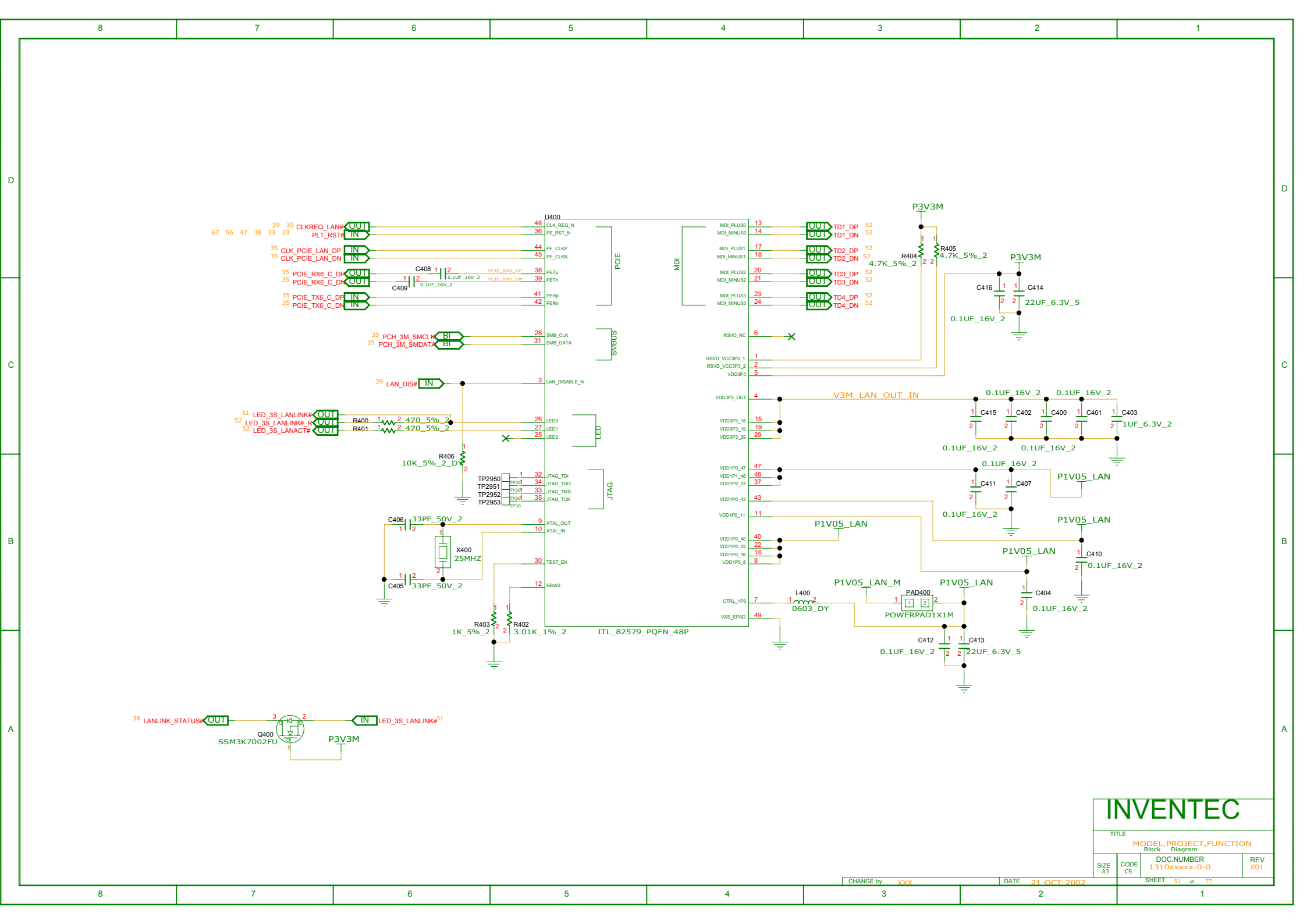

# INVENTEC

TITLE MODEL,PROJECT,FUNCTION  
Block Diagram

SIZE CODE DOC NUMBER REV  
A3 CS 1310xxxx-0-0 X01

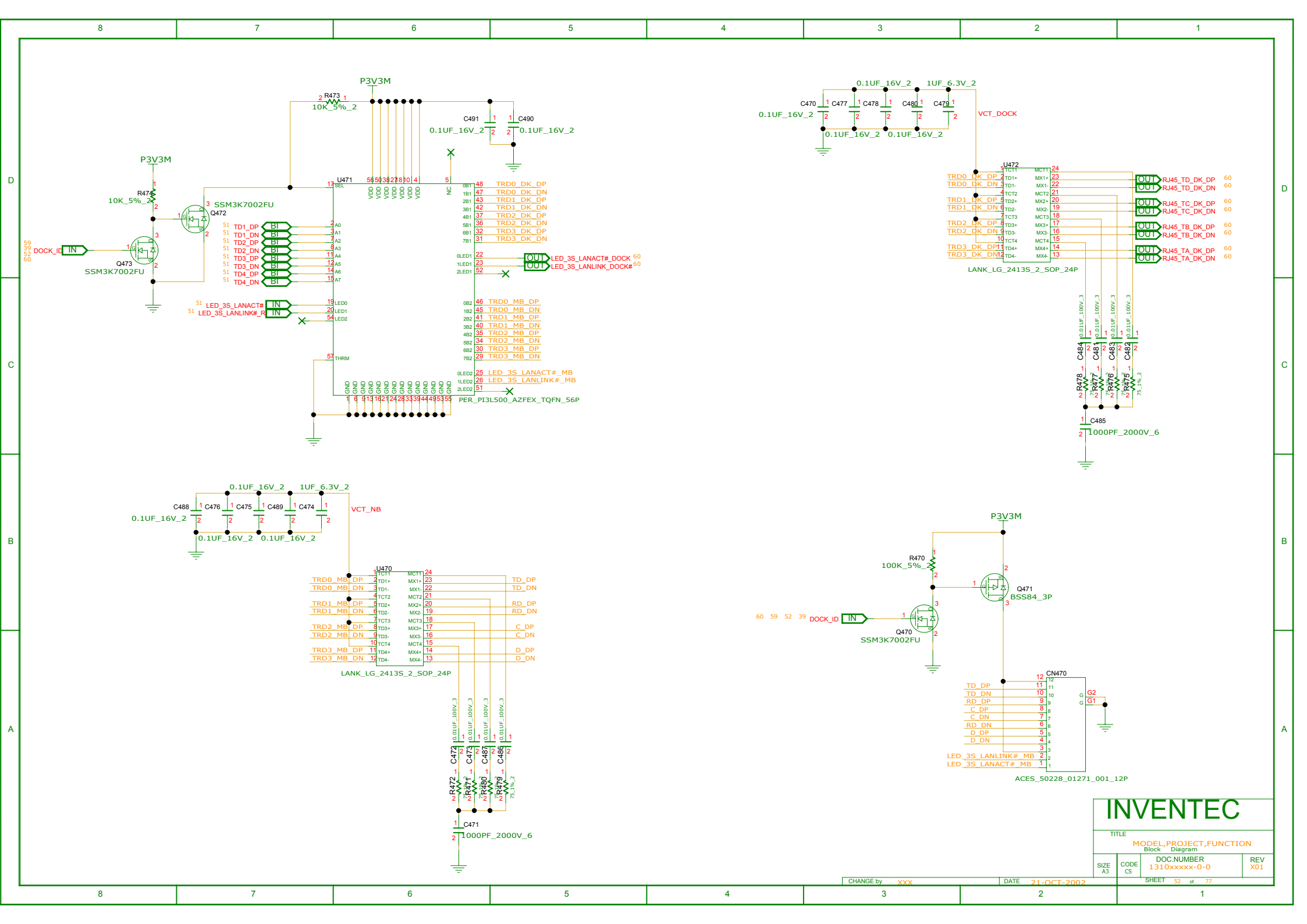

<b>INVENTEC</b>			
TITLE			
MODEL,PROJECT,FUNCTION Block, Diagram			
SIZE A3		DOC NUMBER 1310xxxxx-0-0	
CODE CS		REV X01	
CHANGE by XXX		DATE 21-OCT-2002	
		SHEET 52 of 77	

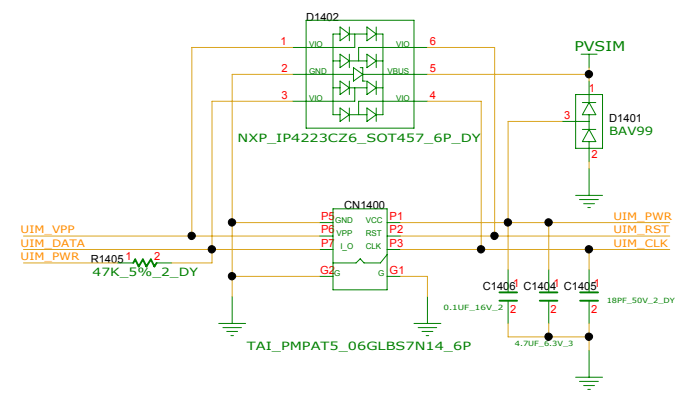
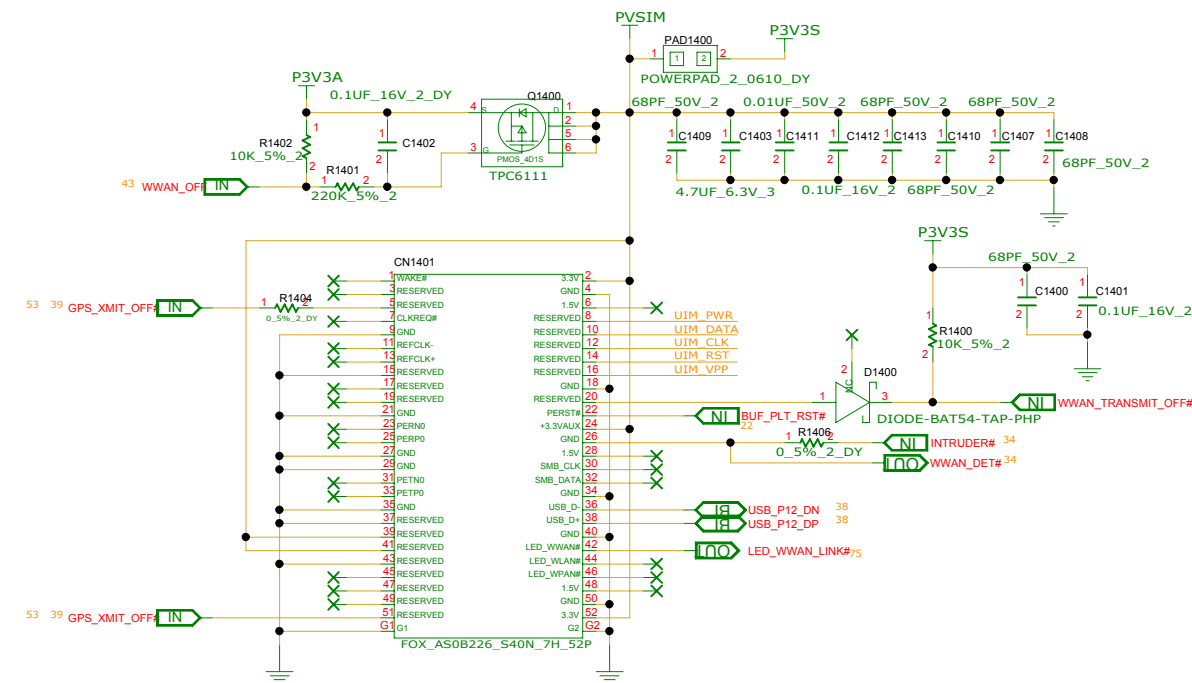
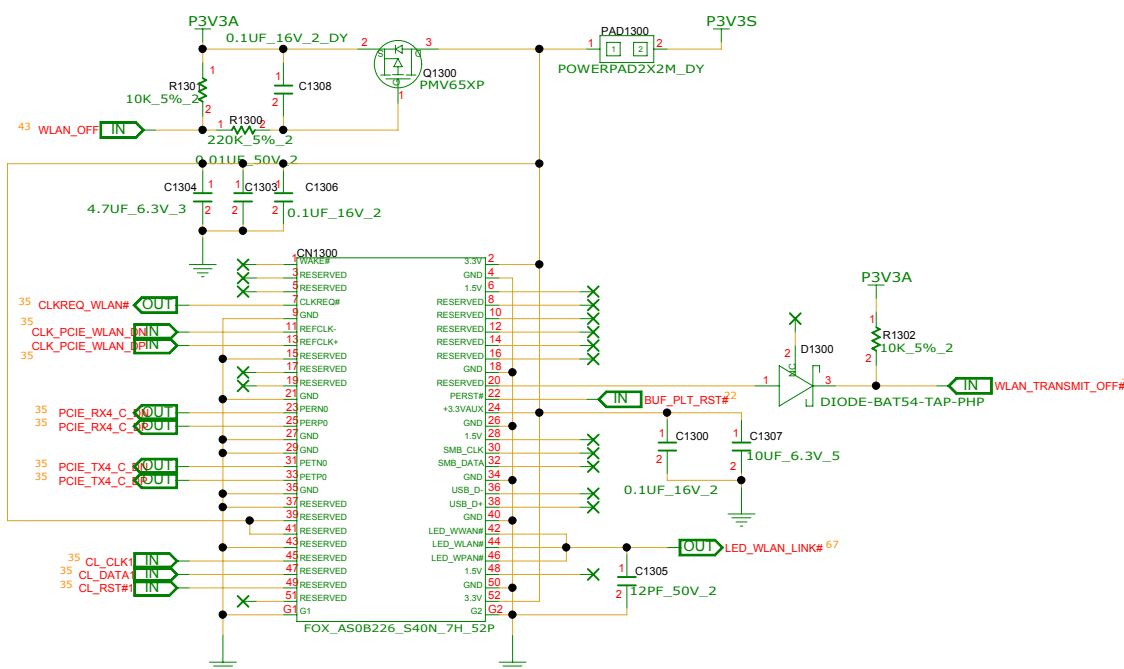

<b>INVENTEC</b>			
TITLE			
MODEL,PROJECT,FUNCTION			
Block Diagram			
SIZE		DOC NUMBER	
A3		1310xxxxx-0-0	
CODE		REV	
CS		X01	
CHANGE by		DATE	
XXX		21-OCT-2002	
SHEET		of	
53		77	

# MSATA--MINI CARD

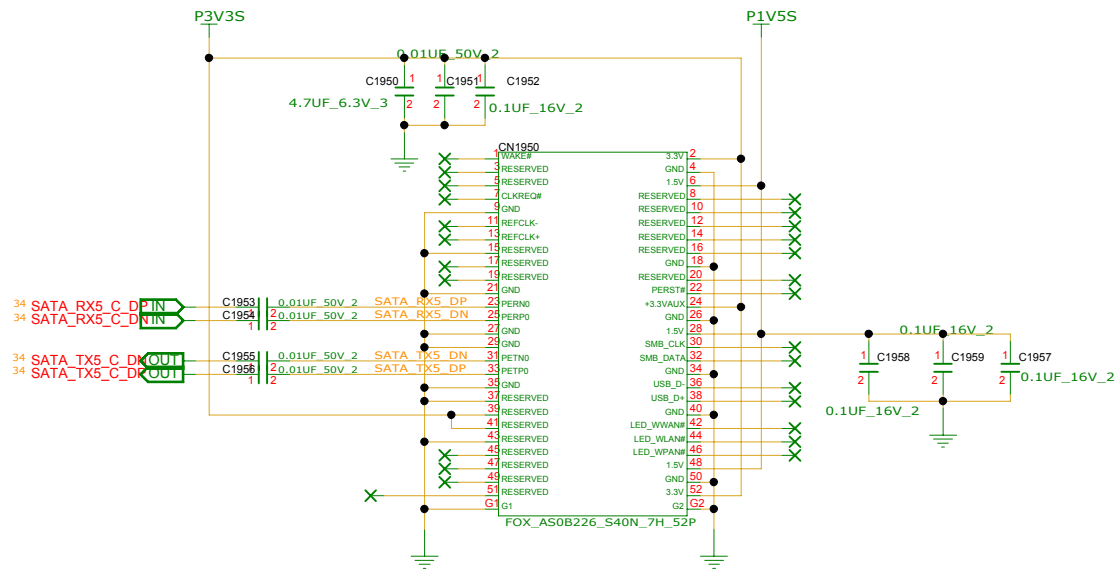

**INVENTEC**

TITLE  
MODEL,PROJECT,FUNCTION  
Block Diagram

DOC NUMBER  
1310xxxxx-0-0

REV  
X01

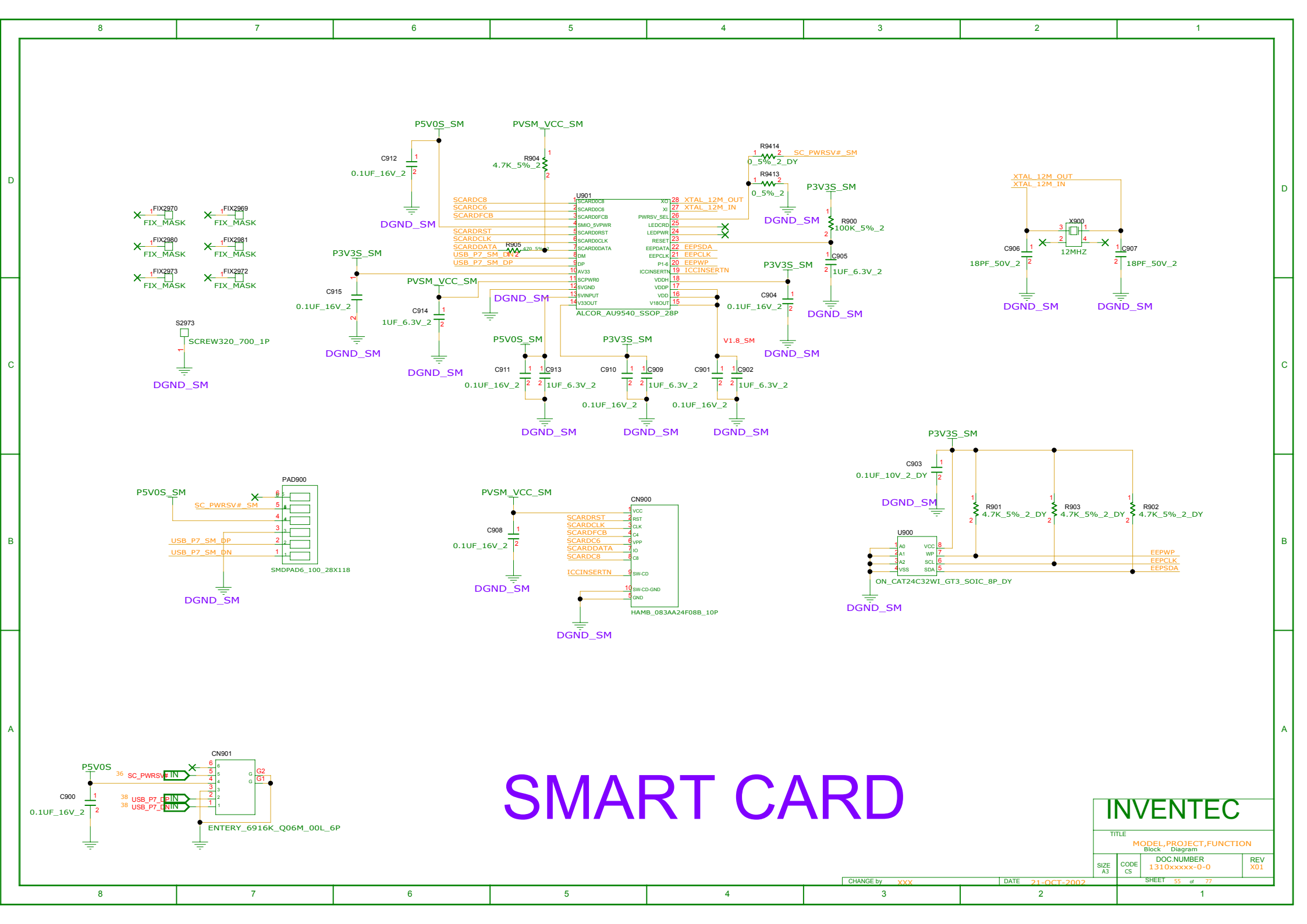

# SMART CARD

<b>INVENTEC</b>			
TITLE			
MODEL,PROJECT,FUNCTION Block Diagram			
SIZE A3	CODE CS	DOC NUMBER 1310xxxxx-0-0	REV X01
CHANGE by XXX		DATE 21-OCT-2002	SHEET 55 of 77

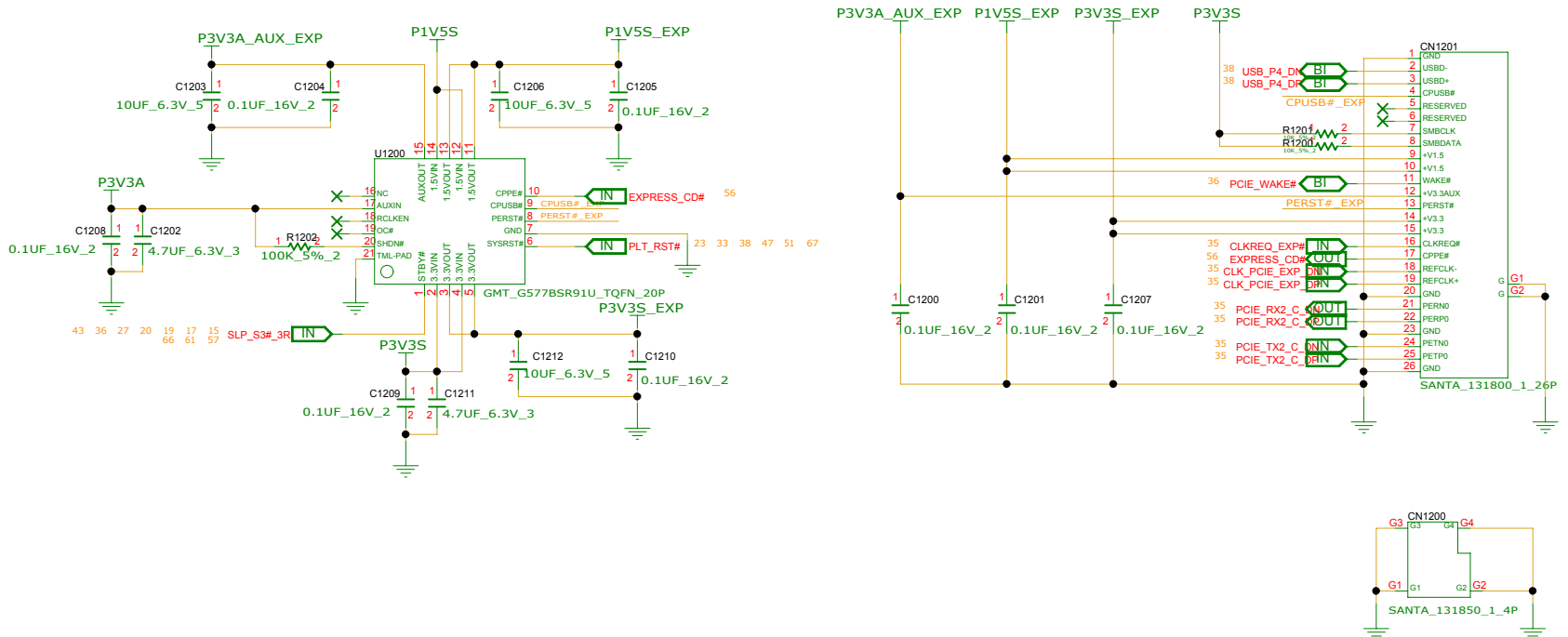

# EXPRESS CARD

<b>INVENTEC</b>			
TITLE Block Diagram			
MODEL, PROJECT, FUNCTION			
SIZE A3		DOC. NUMBER 1310xxxxx-0-0	
CODE CS		REV X01	
CHANGE by XXX		DATE 21-OCT-2002	
SHEET 56		of 77	







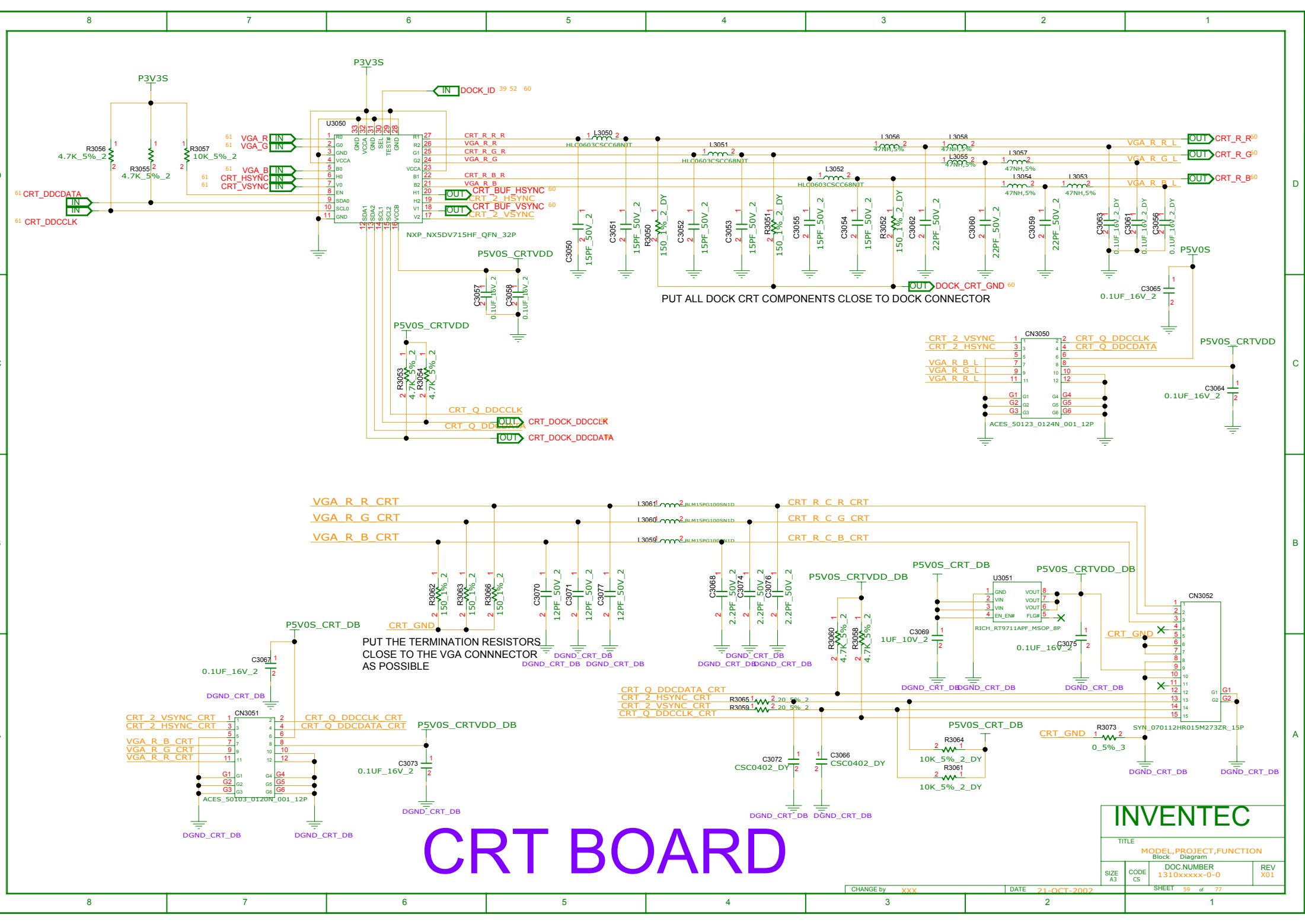

PUT ALL DOCK CRT COMPONENTS CLOSE TO DOCK CONNECTOR

PUT THE TERMINATION RESISTORS CLOSE TO THE VGA CONNECTOR AS POSSIBLE

# CRT BOARD

<b>INVENTEC</b>			
TITLE			
MODEL,PROJECT,FUNCTION			
Block Diagram			
SIZE		CODE	
A3		CS	
DOC NUMBER		REV	
1310xxxxx-0-0		X01	
DATE		SHEET	
21-OCT-2002		59 of 77	

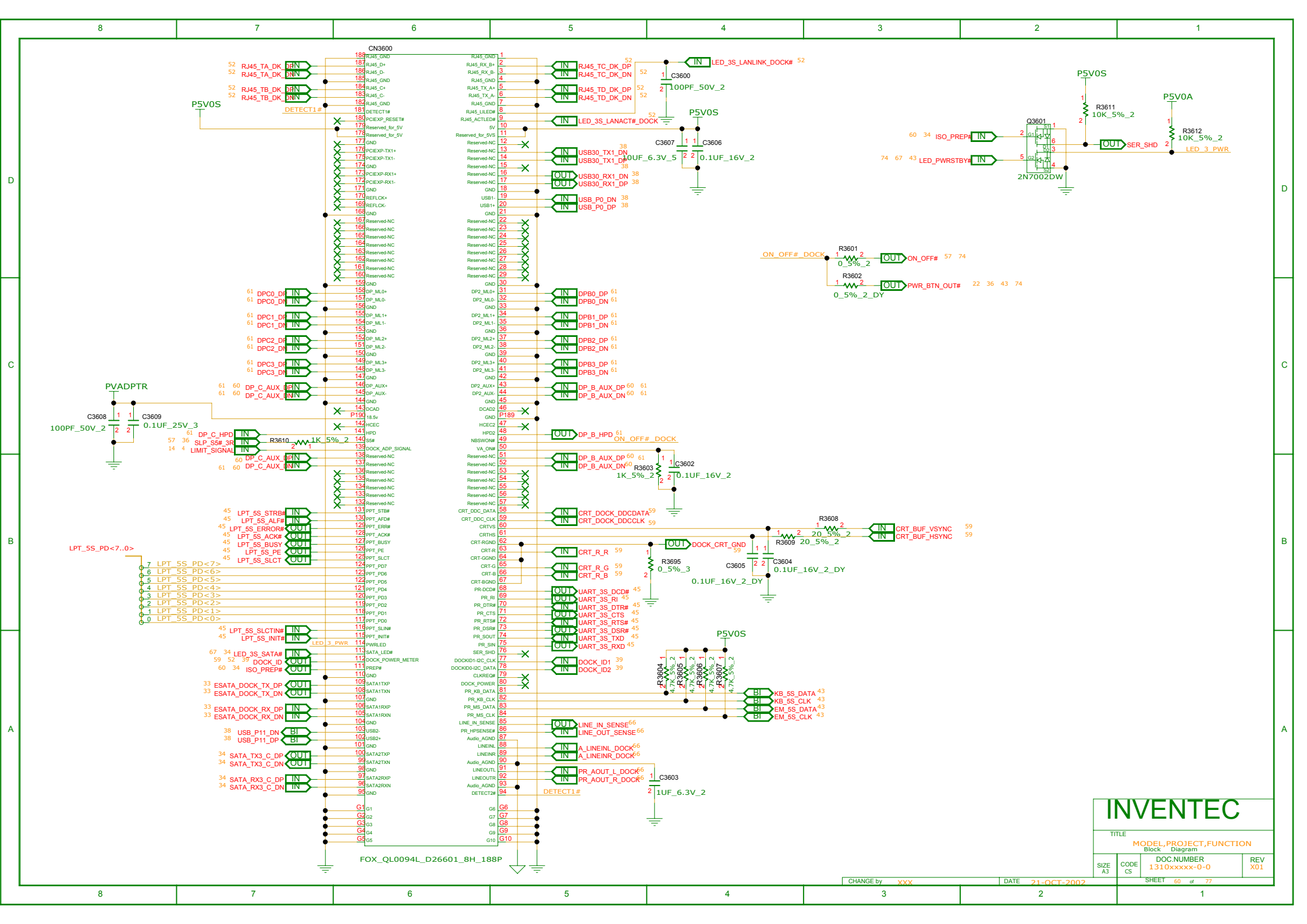

# INVENTEC

TITLE			
MODEL,PROJECT,FUNCTION			
Block Diagram			
SIZE	CODE	DOC NUMBER	REV
A3	CS	1310xxxxx-0-0	X01
SHEET 60 of 77			

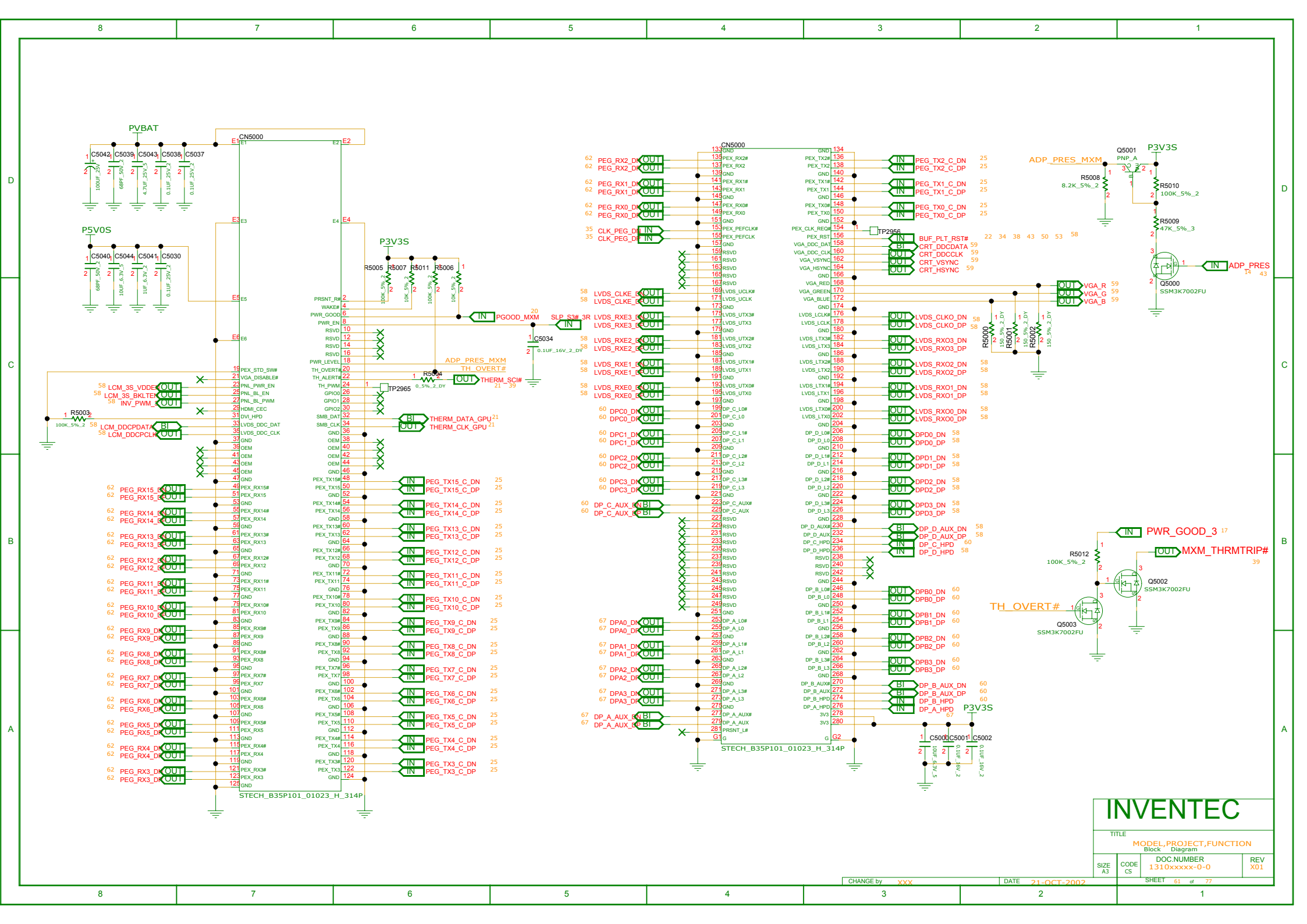

<b>INVENTEC</b>			
TITLE			
MODEL,PROJECT,FUNCTION			
Block Diagram			
SIZE	CODE	DOC NUMBER	REV
A3	CS	1310xxxxx-0-0	X01
CHANGE by		DATE	SHEET
XXX		21-OCT-2002	61 of 77

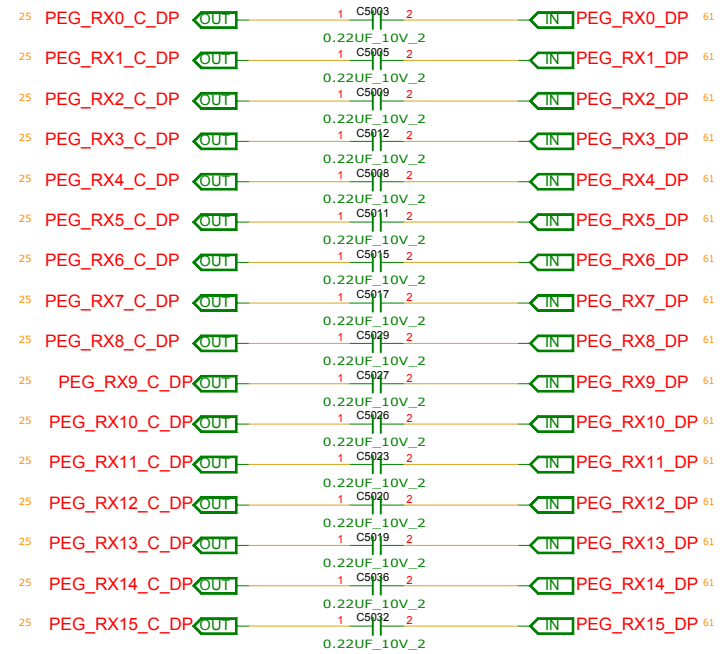
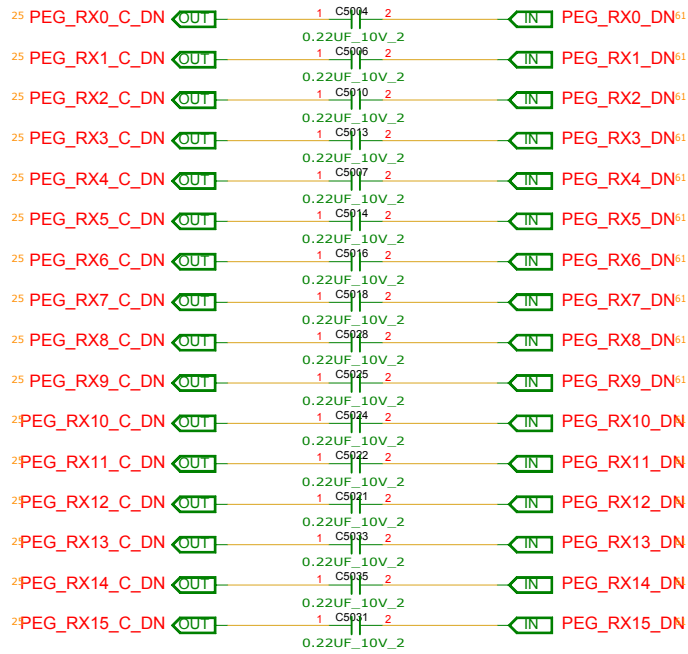

**INVENTEC**

TITLE			
MODEL,PROJECT,FUNCTION Block Diagram			
SIZE A3	CODE CS	DOC NUMBER 1310xxxxx-0-0	REV X01
SHEET 62 of 77			

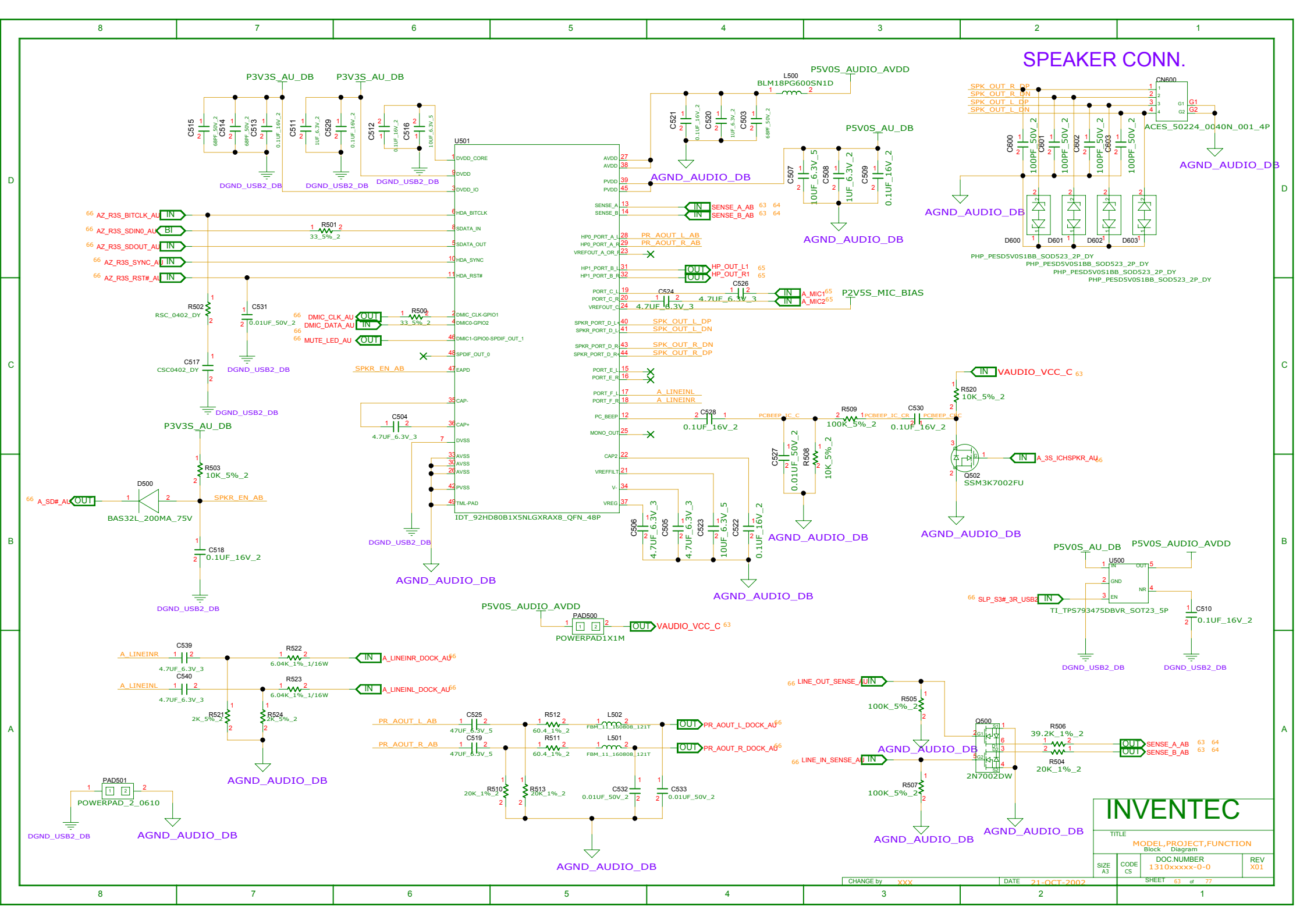

<b>INVENTEC</b>			
TITLE			
MODEL,PROJECT,FUNCTION			
Block Diagram			
SIZE	CODE	DOC NUMBER	REV
A3	CS	1310xxxxx-0-0	X01
CHANGE by XXX			DATE 21-OCT-2002
SHEET 63			of 77

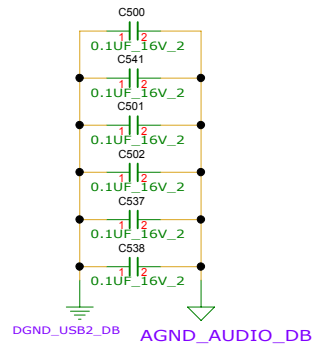
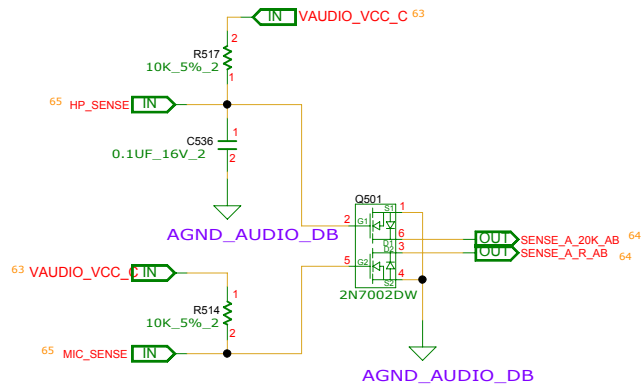
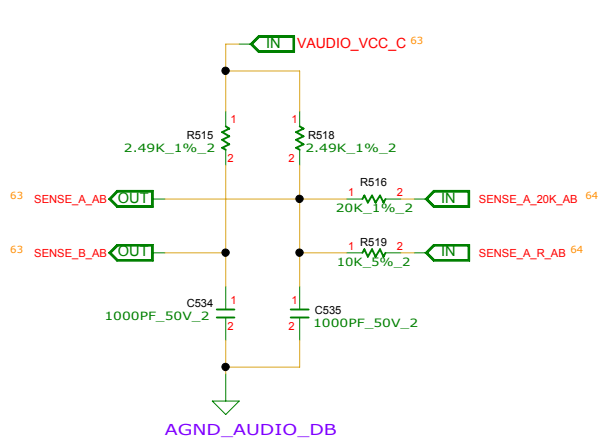

**INVENTEC**

TITLE			
MODEL,PROJECT,FUNCTION Block Diagram			
SIZE A3	CODE CS	DOC NUMBER 1310xxxxx-0-0	REV X01
SHEET 64 of 77			



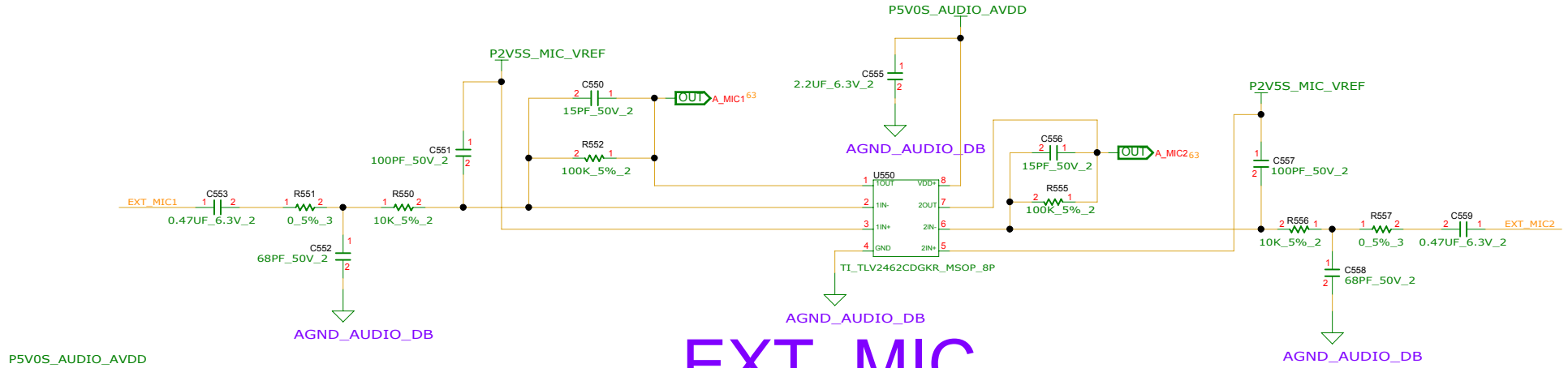

# EXT. MIC

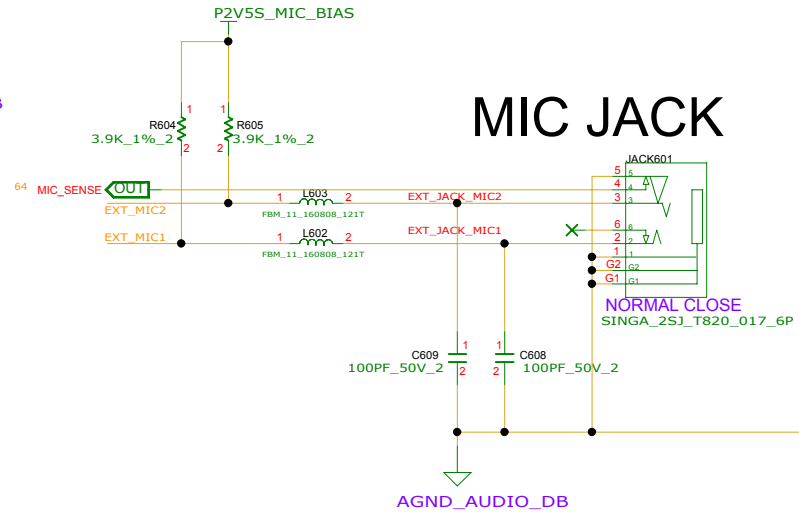
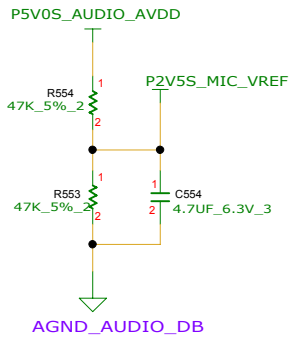

# MIC JACK

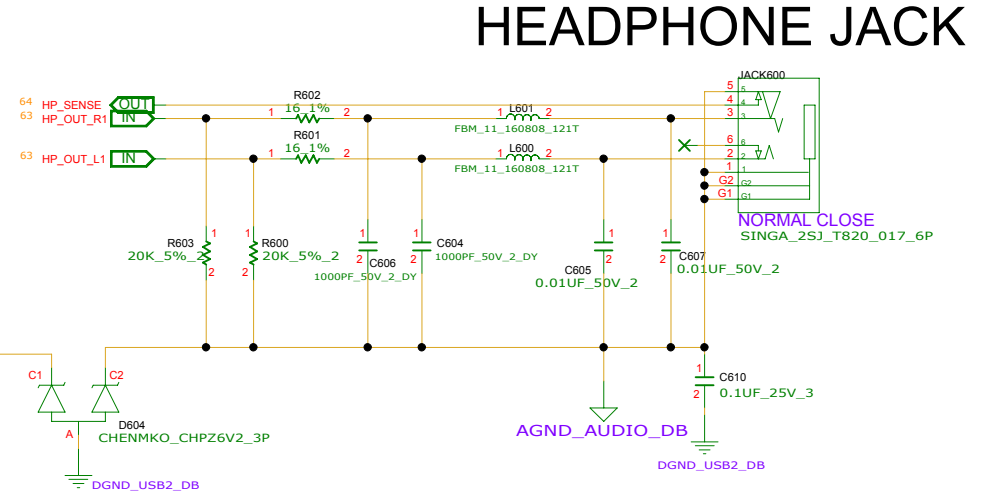

# HEADPHONE JACK

# AUDIO+USB2.0 BOARD

<b>INVENTEC</b>			
TITLE MODEL,PROJECT,FUNCTION Block Diagram			
SIZE A3		CODE CS	
DOC NUMBER 1310xxxxx-0-0		REV X01	
CHANGE by XXX		DATE 21-OCT-2002	
SHEET 65		of 77	

# MB SIDE

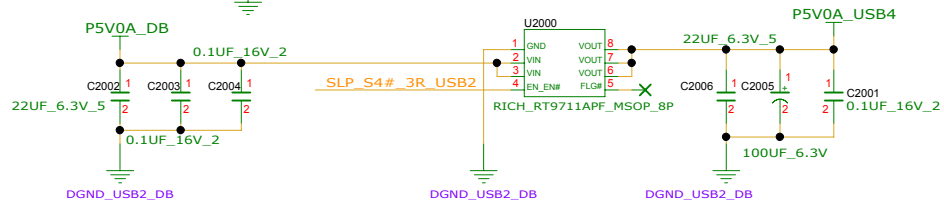
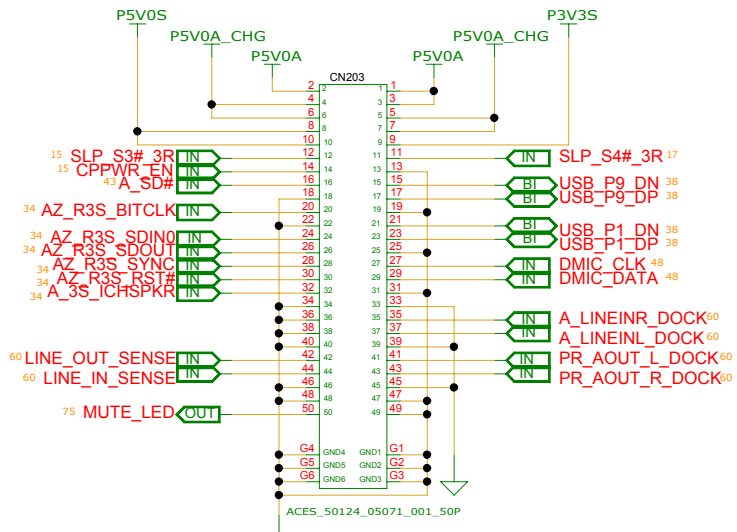

	R2500	R2510	R2508	R2509
TPS2543	TBD	TBD	10K	NI
TPS2540/A	17.8K	NI	NI	0

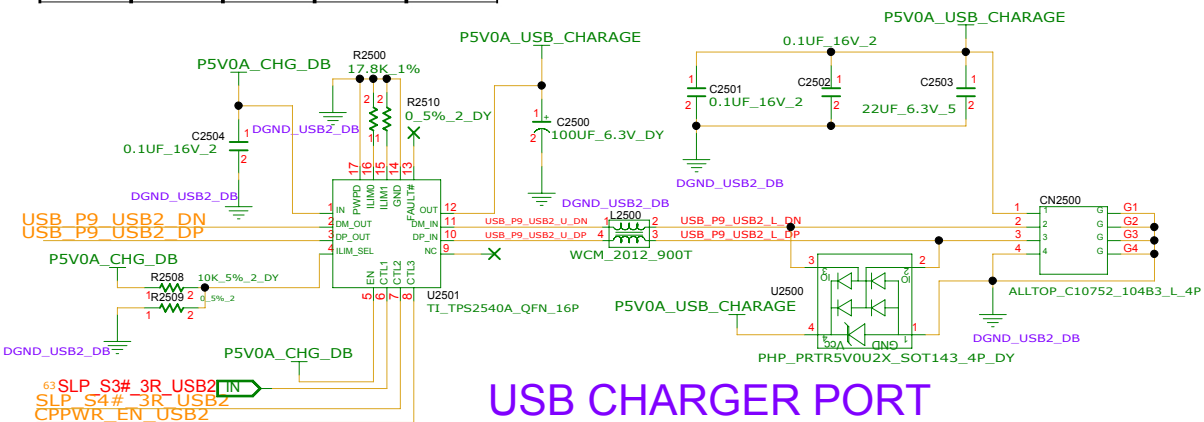

## USB CHARGER PORT

# DB SIDE

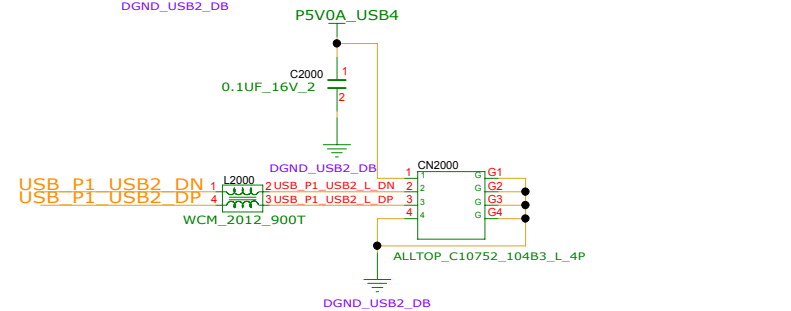
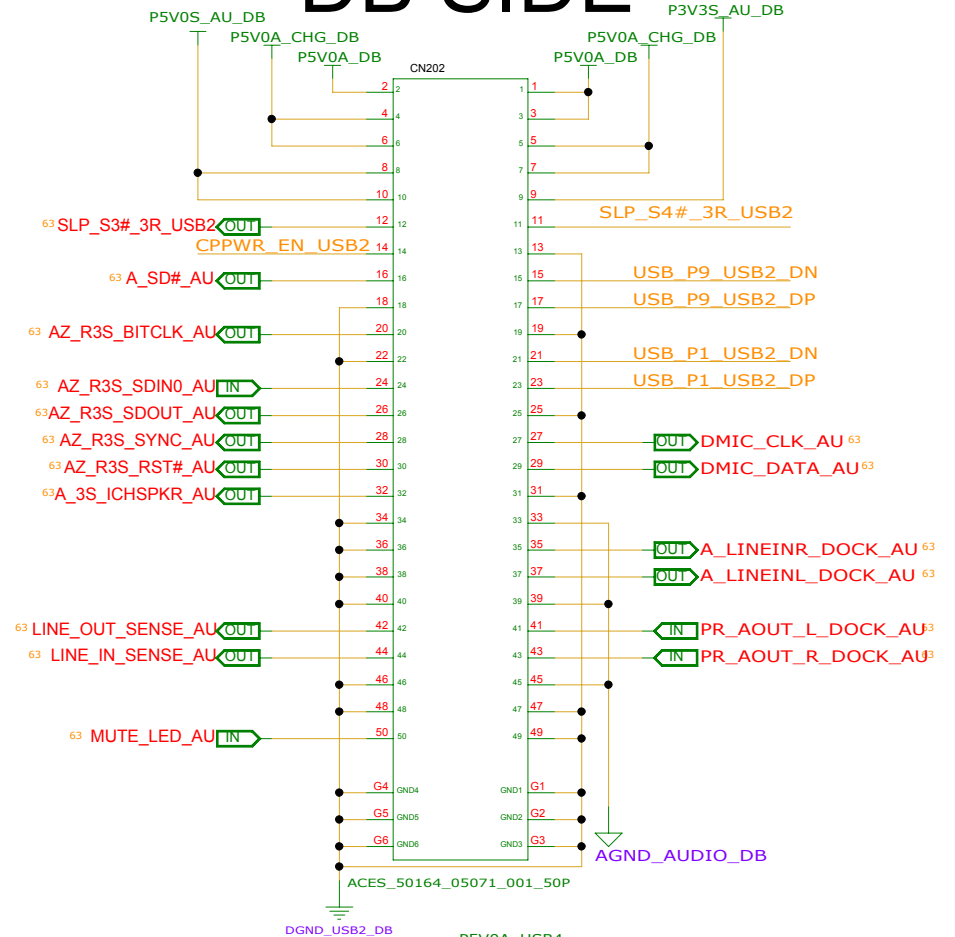

## USB PORT

# INVENTEC

TITLE			
MODEL, PROJECT, FUNCTION Block Diagram			
SIZE A3	CODE CS	DOC NUMBER 1310xxxxx-0-0	REV X01
CHANGE by XXX		DATE 21-OCT-2002	SHEET 66 of 77

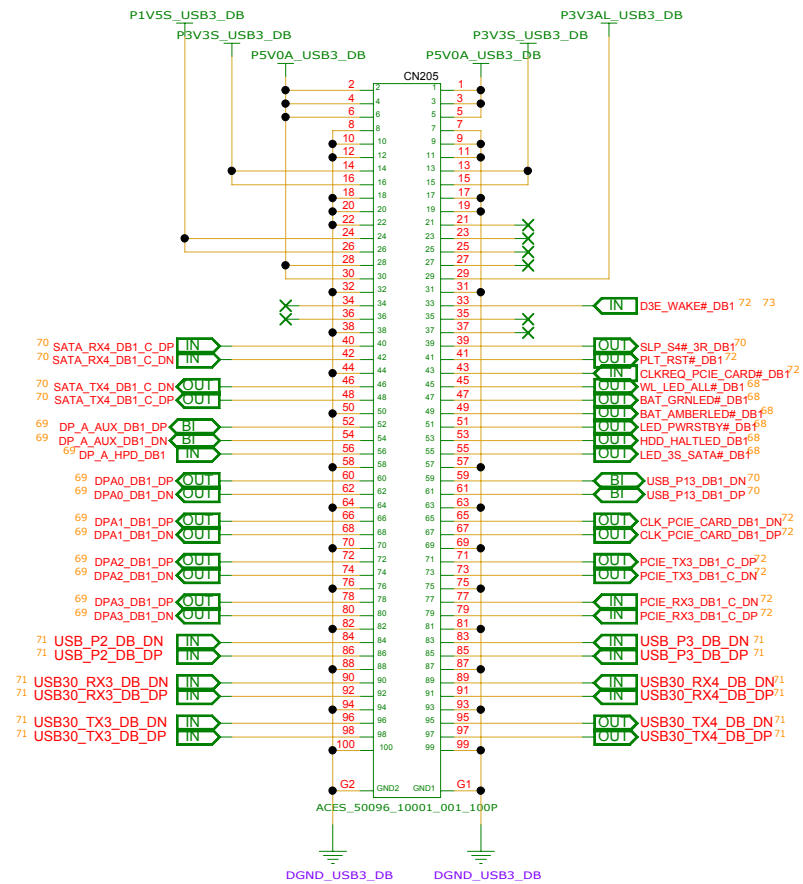
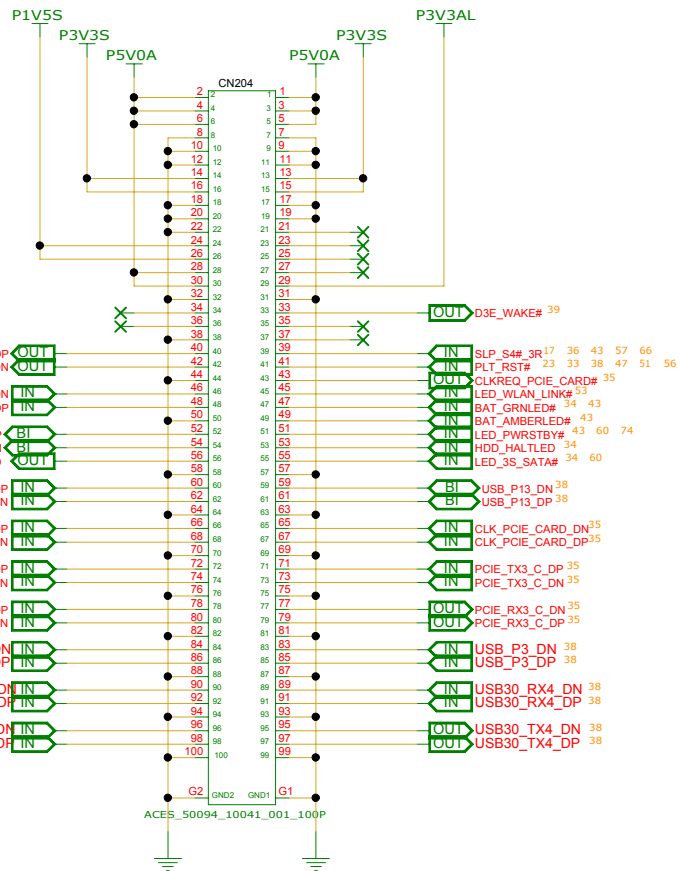

**MB SIDE**

**DB SIDE**

**INVENTEC**

TITLE MODEL,PROJECT,FUNCTION  
Block Diagram

DOC NUMBER 1310xxxxx-0-0 REV X01

SIZE A3 CODE CS SHEET 67 of 77

CHANGE by XXX DATE 21-OCT-2002

### WIRELESS LED

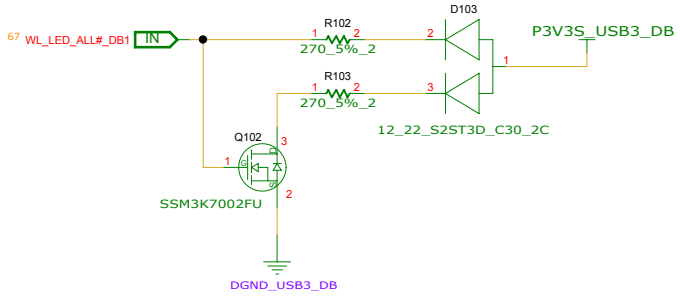

### POWER LED

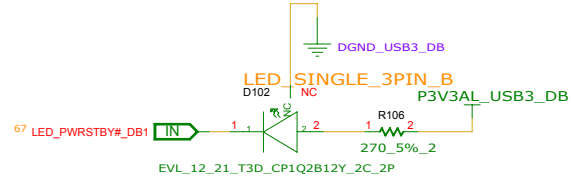

### BATTERY LED

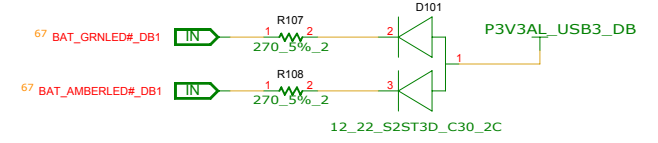

### SATA LED & HDD-HALTED LED

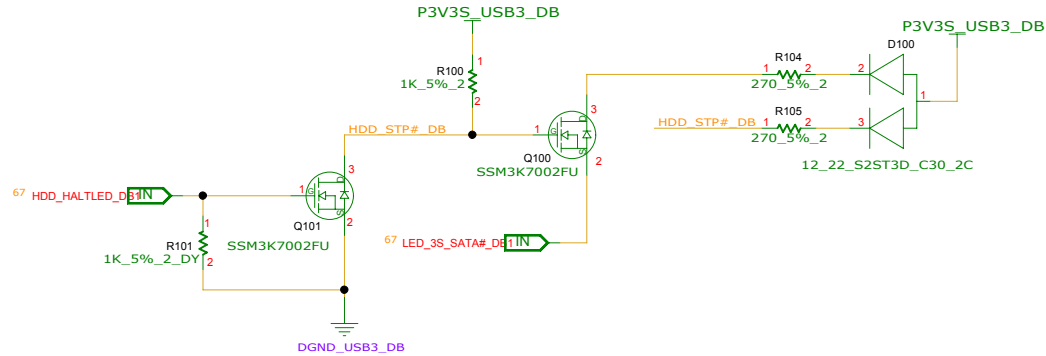

**INVENTEC**

TITLE			
MODEL,PROJECT,FUNCTION			
Block Diagram			
SIZE	CODE	DOC NUMBER	REV
A3	CS	1310xxxxx-0-0	X01
CHANGE by		DATE	SHEET
XXX		21-OCT-2002	68 of 77



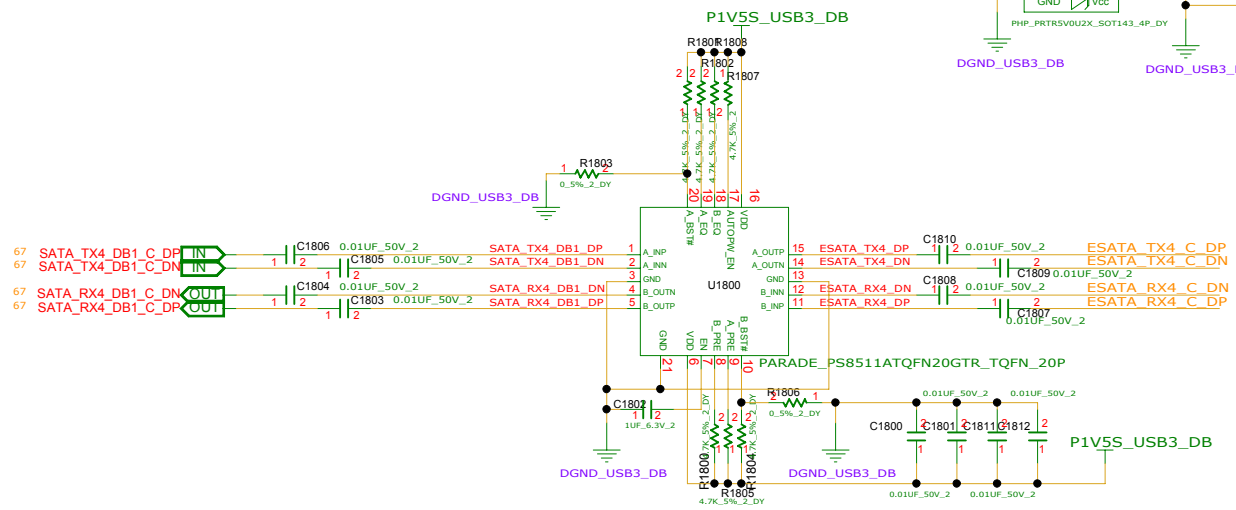
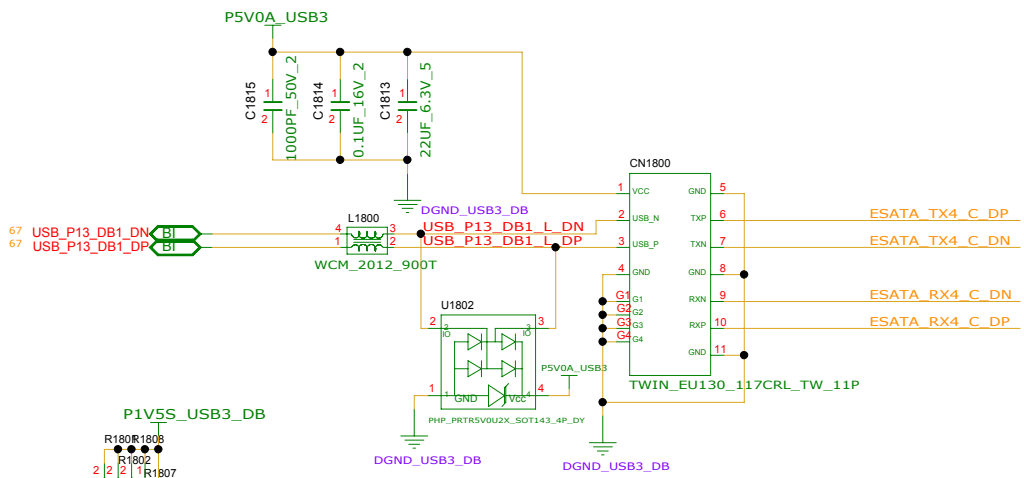
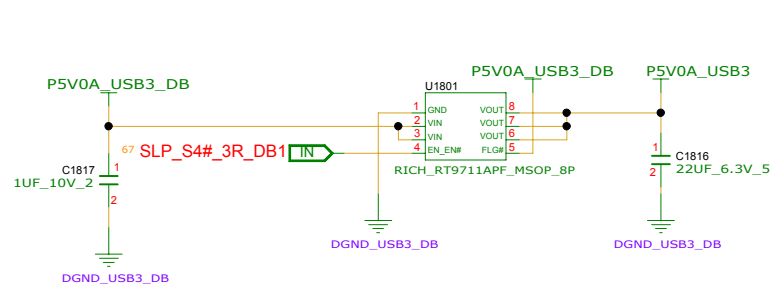

<b>INVENTEC</b>			
TITLE MODEL,PROJECT,FUNCTION Block Diagram			
SIZE A3	CODE CS	DOC NUMBER 1310xxxx-0-0	REV X01
CHANGE by XXX		DATE 21-OCT-2002	SHEET 70 of 77

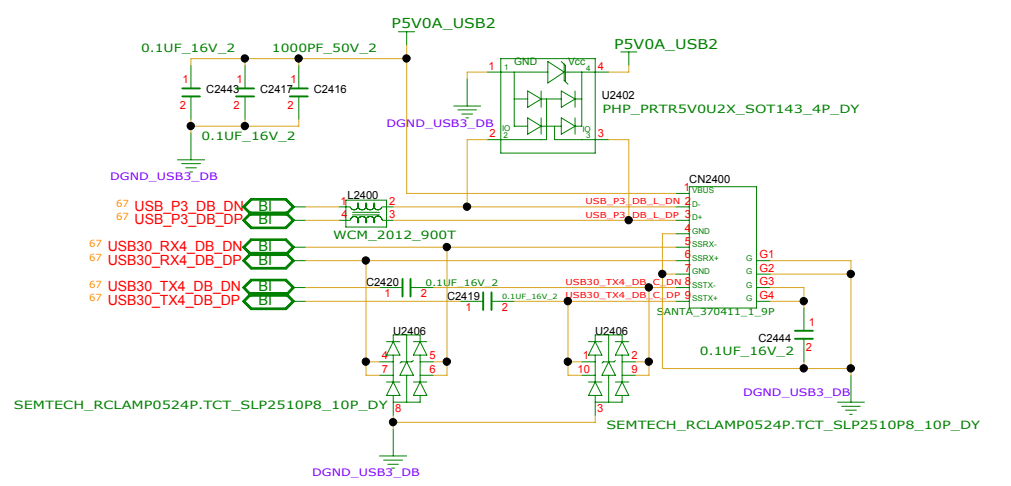
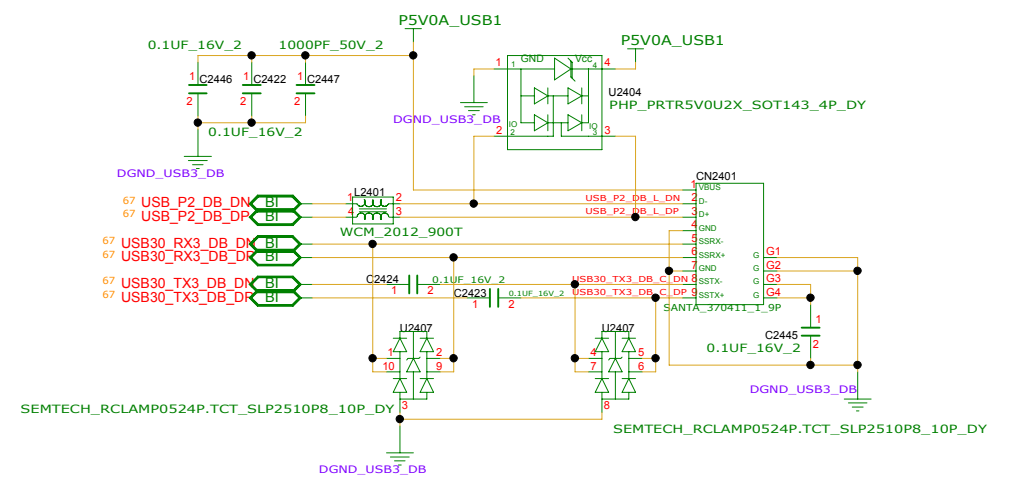
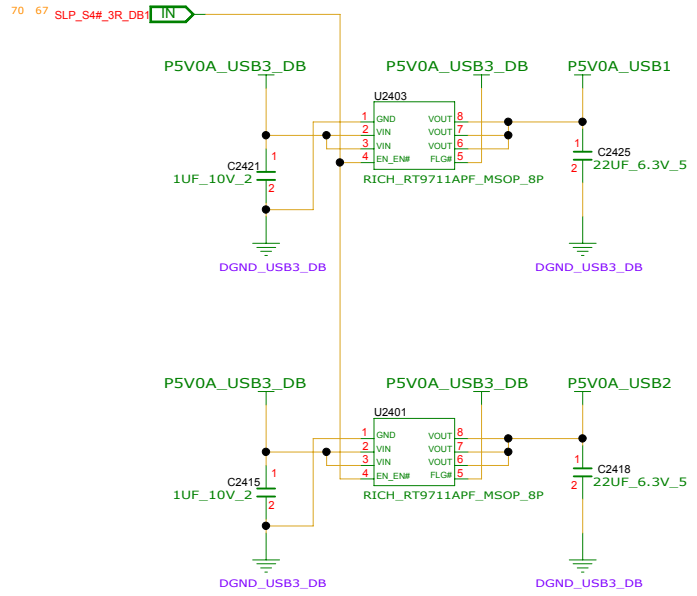

<b>INVENTEC</b>			
TITLE MODEL,PROJECT,FUNCTION Block Diagram			
SIZE A3	CODE CS	DOC NUMBER 1310xxxxx-0-0	REV X01
CHANGE by XXX		DATE 21-OCT-2002	SHEET 71 of 77

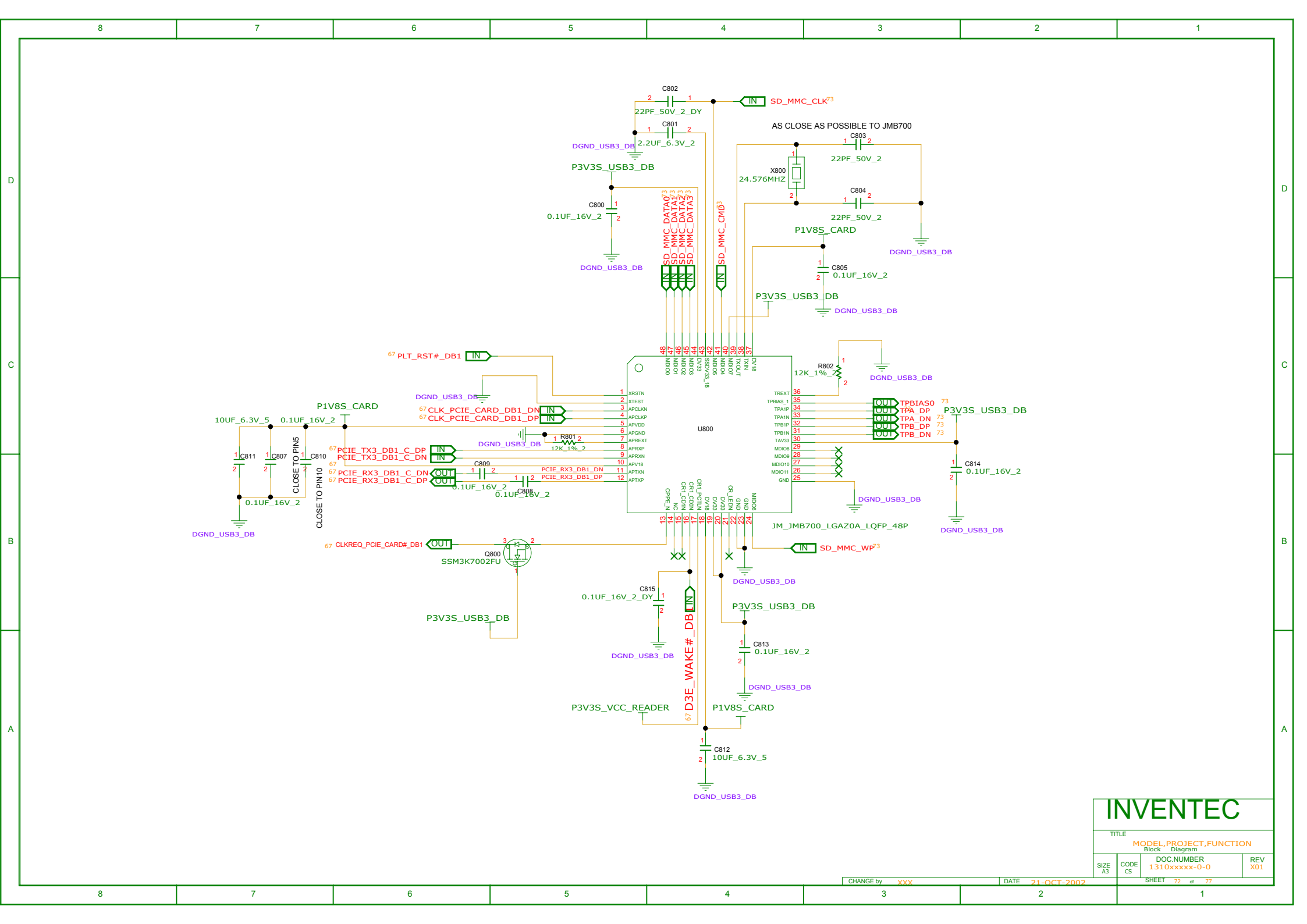

# INVENTEC

TITLE			
MODEL,PROJECT,FUNCTION Block Diagram			
SIZE A3		CODE CS	REV X01
DOC NUMBER 1310xxxxx-0-0		SHEET 72 of 77	



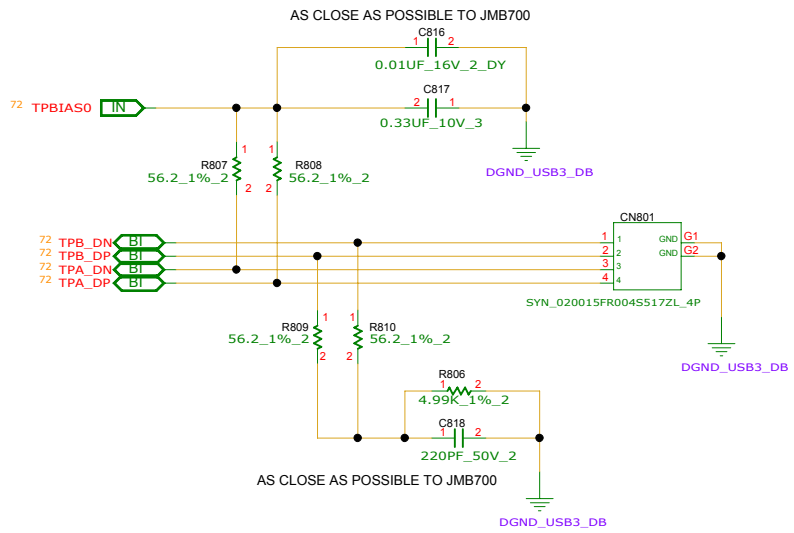

1394 CONN.

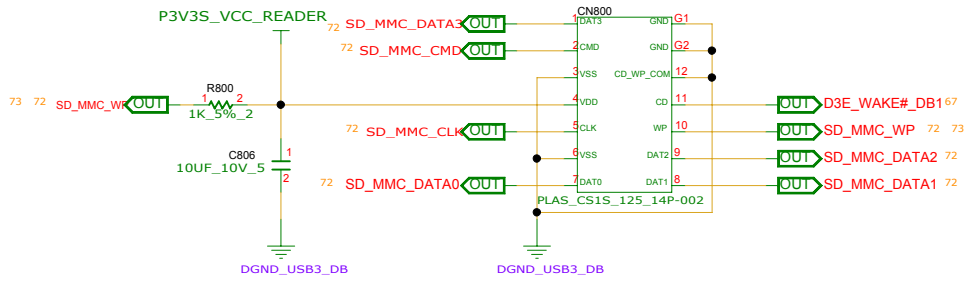

SD/MMC CONN

<b>INVENTEC</b>			
TITLE MODEL,PROJECT,FUNCTION Block Diagram			
SIZE A3	CODE CS	DOC NUMBER 1310xxxxx-0-0	REV X01

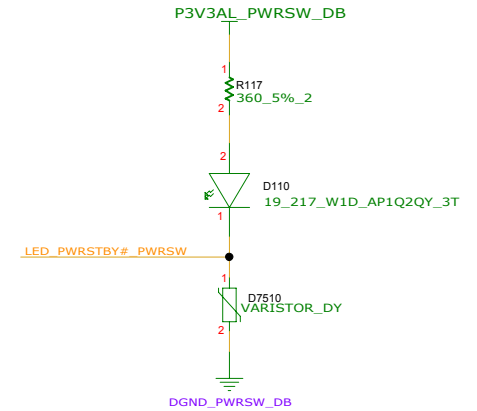
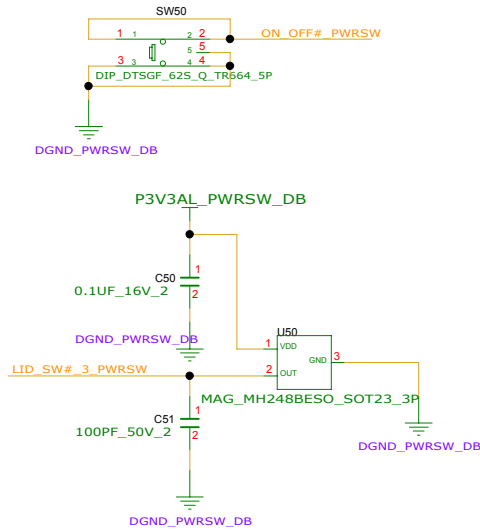
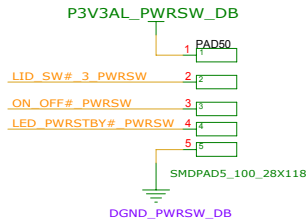

# POWER BUTTON & LID SWITCH BOARD

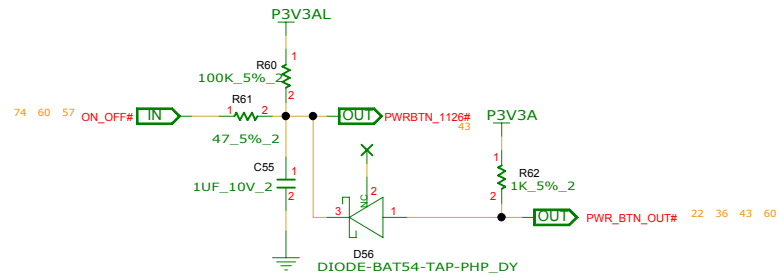
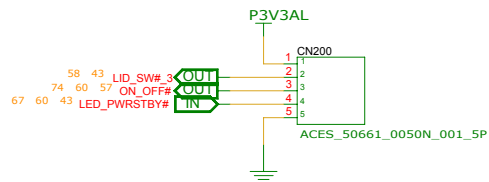

**INVENTEC**

TITLE			
MODEL,PROJECT,FUNCTION			
Block Diagram			
SIZE	CODE	DOC NUMBER	REV
A3	CS	1310xxxxx-0-0	X01

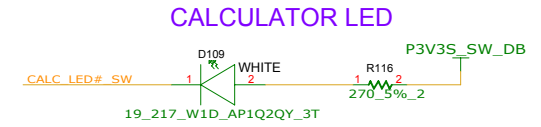
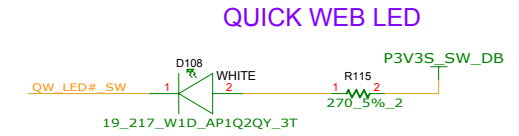
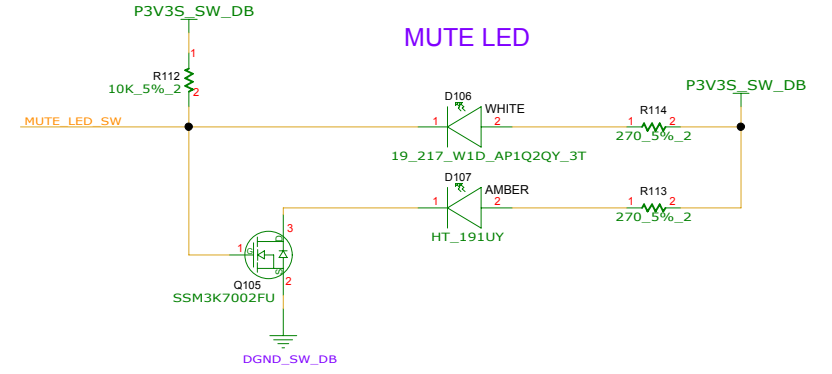
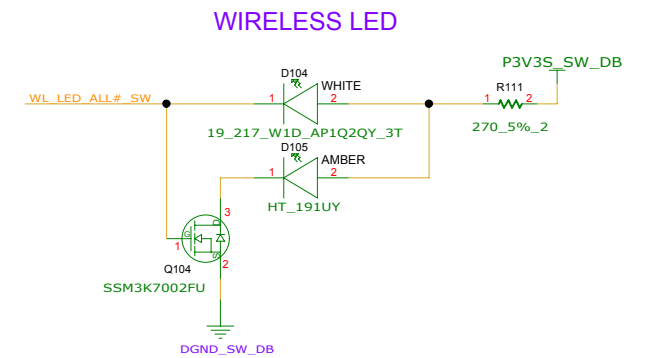
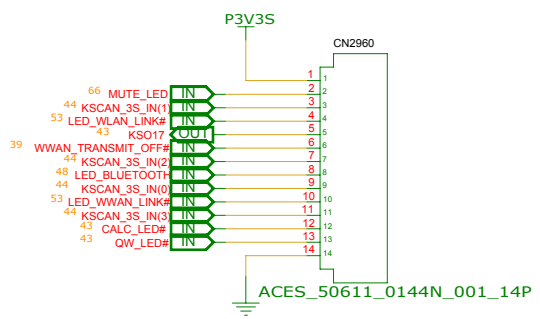
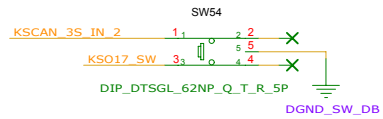
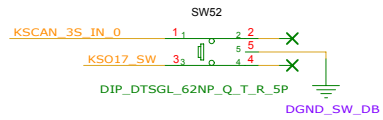
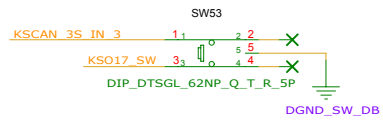
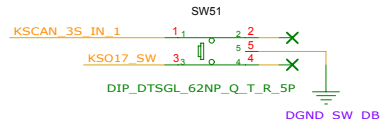
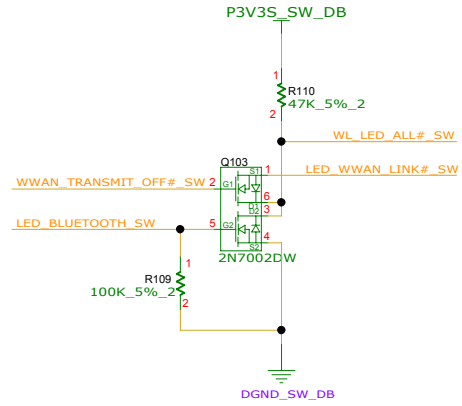
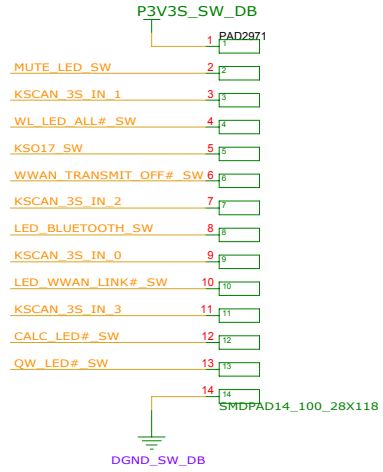

<b>INVENTEC</b>			
TITLE			
MODEL,PROJECT,FUNCTION			
Block Diagram			
SIZE	CODE	DOC NUMBER	REV
A3	CS	1310xxxx-0-0	X01
CHANGE by		DATE	SHEET
XXX		21-OCT-2002	75 of 77

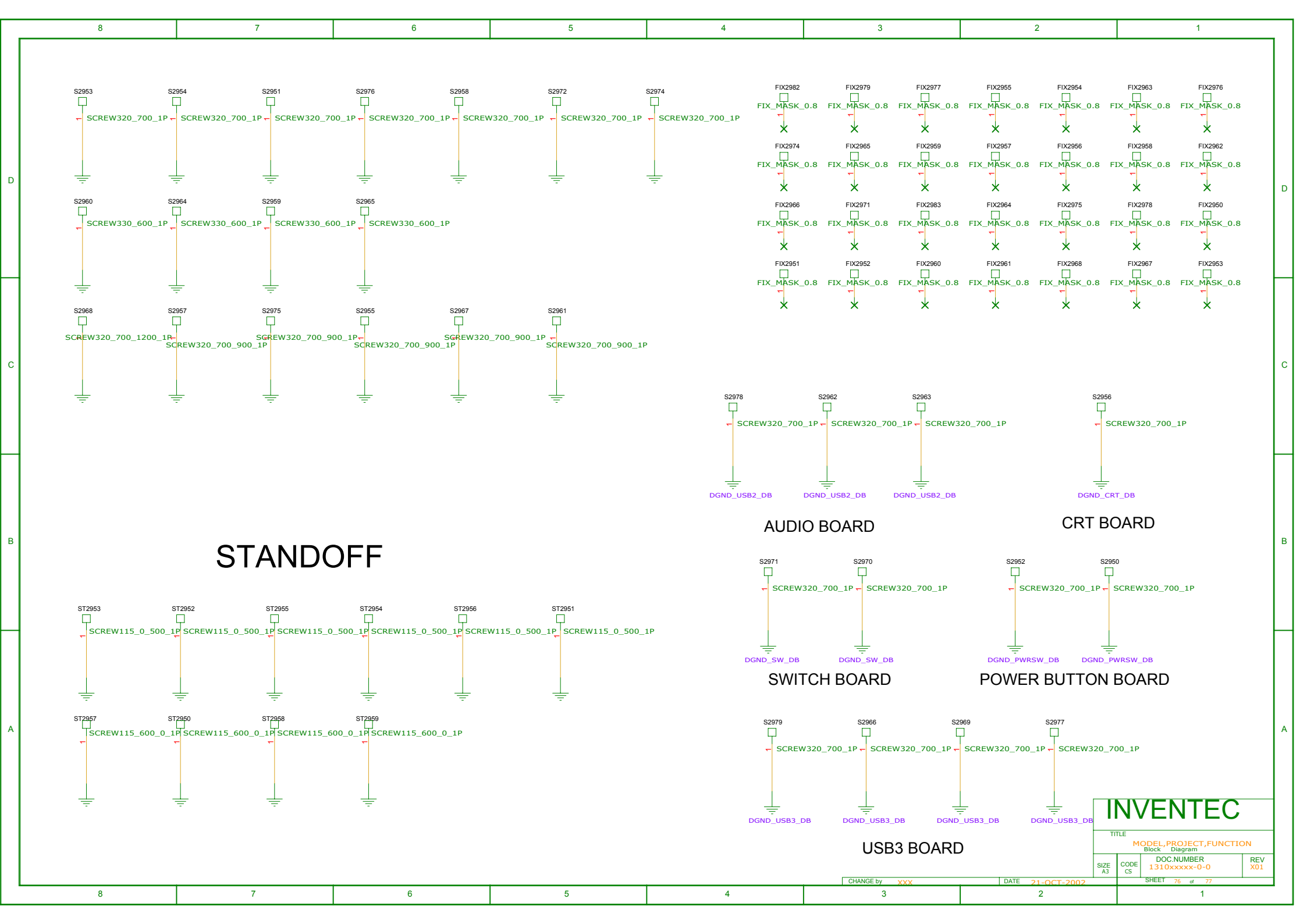

**STANDOFF**

**AUDIO BOARD**

**CRT BOARD**

**SWITCH BOARD**

**POWER BUTTON BOARD**

**USB3 BOARD**

<b>INVENTEC</b>			
TITLE Block Diagram			
MODEL, PROJECT, FUNCTION			
SIZE A3	CODE CS	DOC NUMBER 1310xxxxx-0-0	REV X01
CHANGE by XXX		DATE 21-OCT-2002	SHEET 76 of 77

8

7

6

5

4

3

2

1

D

D

C

C

B

B

A

A

# INVENTEC

TITLE		
MODEL,PROJECT,FUNCTION Block Diagram		
SIZE A3	CODE CS	DOC.NUMBER 1310xxxxx-0-0
SHEET 77 of 77		REV X01

CHANGE by **XXX** DATE **21-OCT-2002**

8

7

6

5

4

3

2

1