

1	2	3	4	5	6	7	8
---	---	---	---	---	---	---	---

THIS DRAWING AND SPECIFICATIONS, HEREIN, ARE THE PROPERTY OF INVENTEC CORPORATION AND SHALL NOT BE REPRODUCED, COPIED, OR USED IN WHOLE OR IN PART AS THE BASIS FOR THE MANUFACTURE OR SALE OF ITEMS WITHOUT WRITTEN PERMISSION, INVENTEC CORPORATION 2011 ALL RIGHT RESERVED

HSF Property : **Halogen-Free+RoHS2**

AEROSMITH

MV A03 4-DIMM MB

2011.08.26

DATE	CHANGE NO.	REV
1	2	

DRAWER	EE	DATE	POWER	DATE	INVENTEC			
DESIGN								
CHECK								
RESPONSIBLE								
TITLE					AEROSMITH			
SIZE =	3	VER :			SIZE	CODE	DOC. NUMBER	REV
FILE NAME :	XXXX XXXXXX-XX				A3	CS	1310A24383-0-MTH	A03
P/N	XXXXXXXXXXXX				SHEET	1	OF	61

1	2	3	4	5	6	7	8
---	---	---	---	---	---	---	---

TABLE OF CONTENTS

<p>5- DC IN & BATTERY CHARGER 6- SELECT & BATTERY CONN 7- SYSTEM POWER(3V/5V) 8- SYSTEM POWER(+V1.5/+V0.75S) 9- SYSTEM POWER(+V1.8S/Turbo Boost) 10- SYSTEM POWER(+VCCP/+V1.05M_LAN) 11- CPU POWER(+V0.85S) 12- CPU POWER(+VCC_CORE) 13- CPU POWER(+VCC_CORE) 14- POWER(SLEEP) 15- POWER(SEQUENCE) 16- FAN & THERMAL SENSOR 17- XDP CONNECTOR 18- SANDY BRIDGE_1 19- SANDY BRIDGE_2 20- SANDY BRIDGE_3 21- SANDY BRIDGE_4 22- SANDY BRIDGE_5 23- SANDY BRIDGE_6 24- DDR3-DIMM0(A) 25- DDR3-DIMM1(A) 26- DDR3-DIMM0(B) 27- DDR3-DIMM1(B) 28- DDR3 VREF 29- PCH_1 30- PCH_2</p>	<p>31- PCH_3 32- PCH_4 33- PCH_5 34- PCH_6 35- PCH_7 36- PCH_8 37- PCH_9 38- KBC & SPI 39- KEYBOARD 40- SUPER I/O 41- KB BL&POINT STICK&TOUCH PAD 42- HDD & ODD 43- BT & FP & CAMERA 44- ACCELEROMETER 45- TPM & MDC 46- LAN PHY 47- LAN SWITCH RJ45 48- WLAN & WWAN & SIM CARD 49- FLASH CACHE--MINI CARD 50- SMART CARD 51- EXPRESS CARD 52- LED 53- LCM 54- CRT 55- DOCKING CNTR 56- MXM CONNECTOR</p>	<p>57- AUDIO 58- AUDIO 59- USB PORT(CHARGER) 60- SYSTEM LED 61- DISPLAY PORT 62- USB & eSATA COMBO 63- USB 3.0 CONTROLLER 64- USB 3.0 CONNECTOR 65- CARD READER 66- SD/MMC & 1394A 67- CFAST 68- POWER SW & HALL SENSOR 69- SYSTEM SW & LED 70- SCREW</p>
--	--	--

INVENTEC

TITLE			
Aerosmith			
SIZE	CODE	DOC. NUMBER	REV
A3	CS	1310A24383-0-MTR	A03
SHEET		OF	
2		OF	61

CHANGE by *Evon Shih* 26-Aug-2011

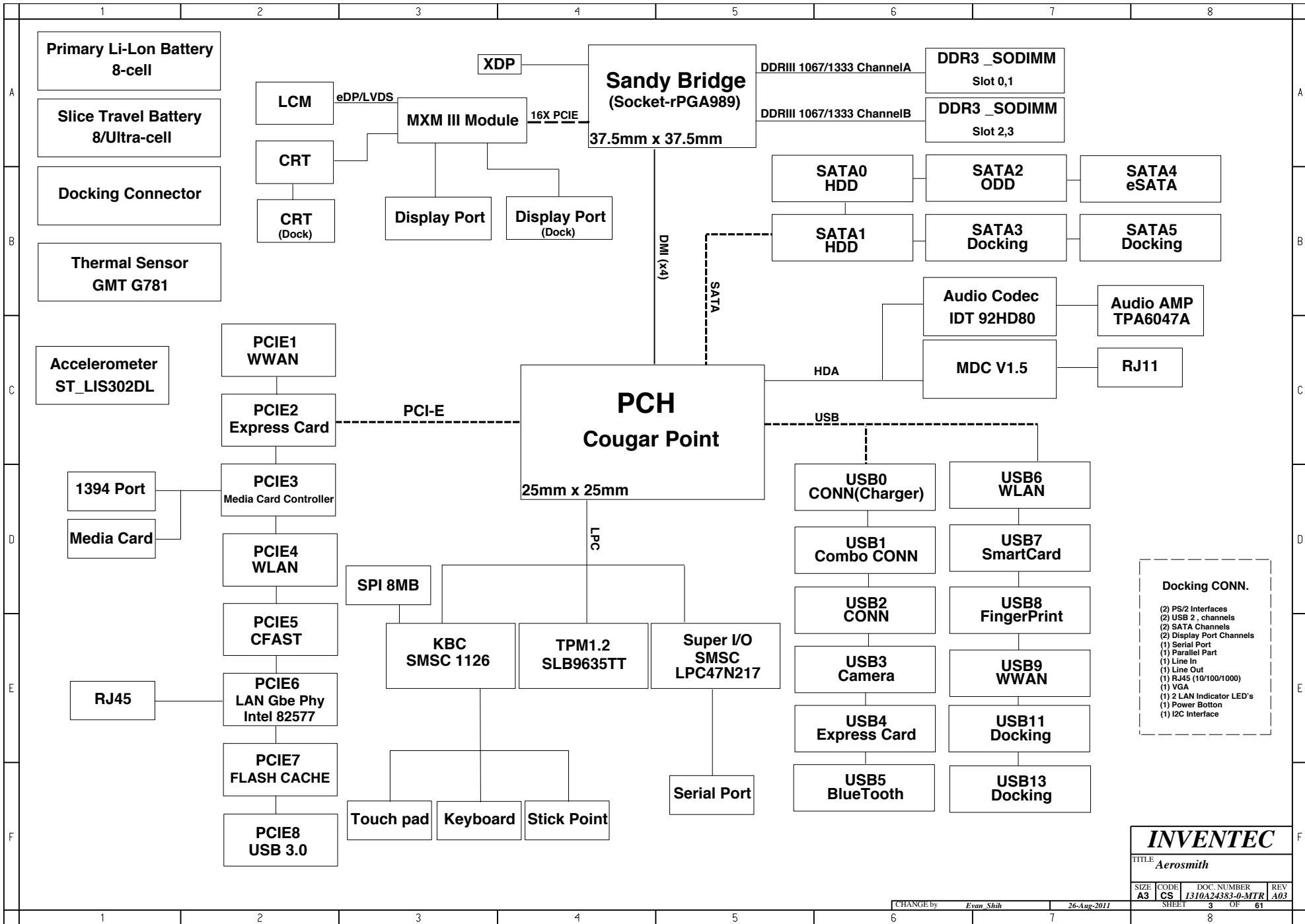

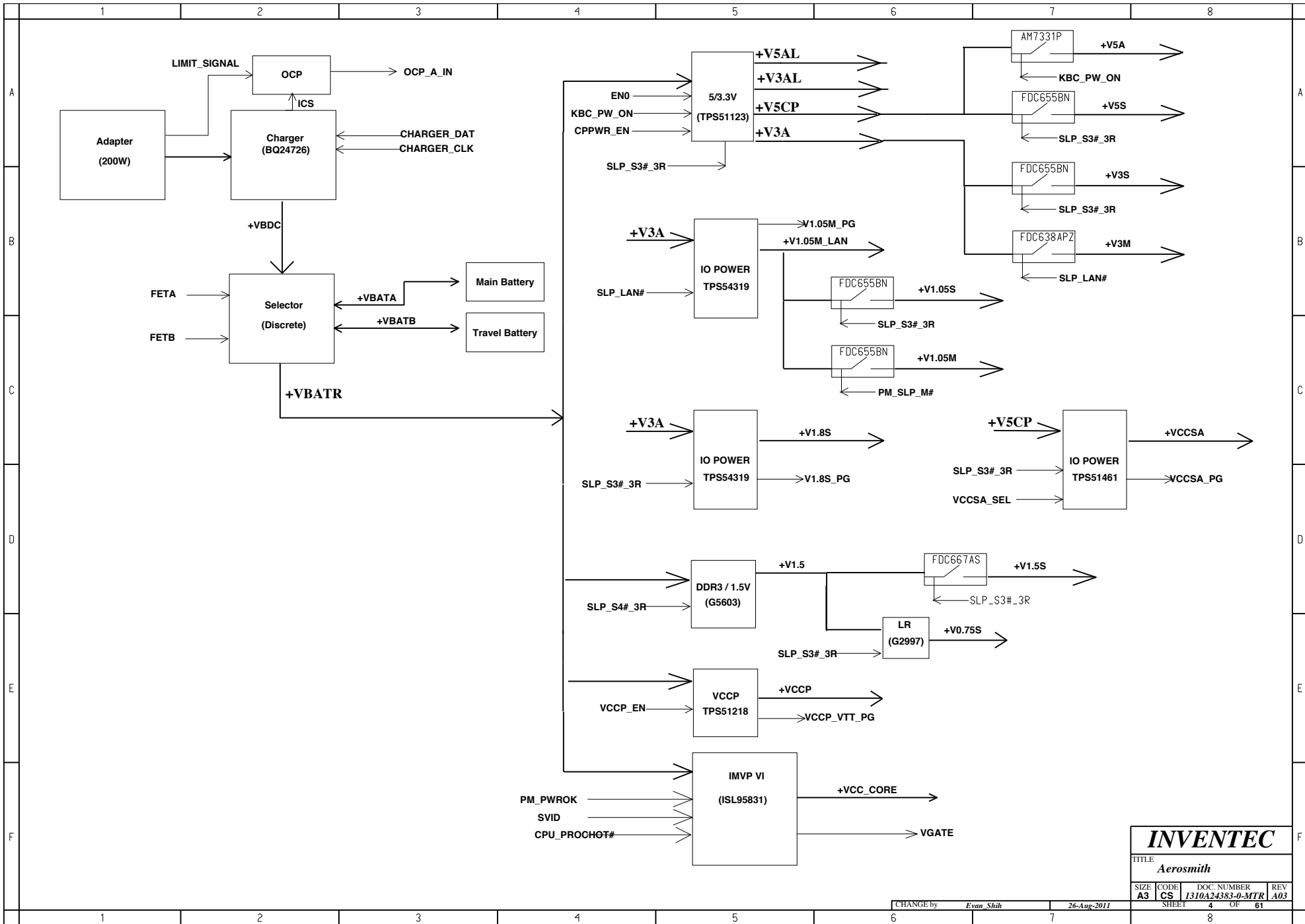

INVENTEC			
TITLE <i>Aeromsmith</i>			
SIZE A3	CODE CS	DOC. NUMBER <i>1310A24383-0-MTR</i>	REV A03
CHANGE by <i>Evon Shih</i>		26-Aug-2011	
SHEET		4 OF 61	

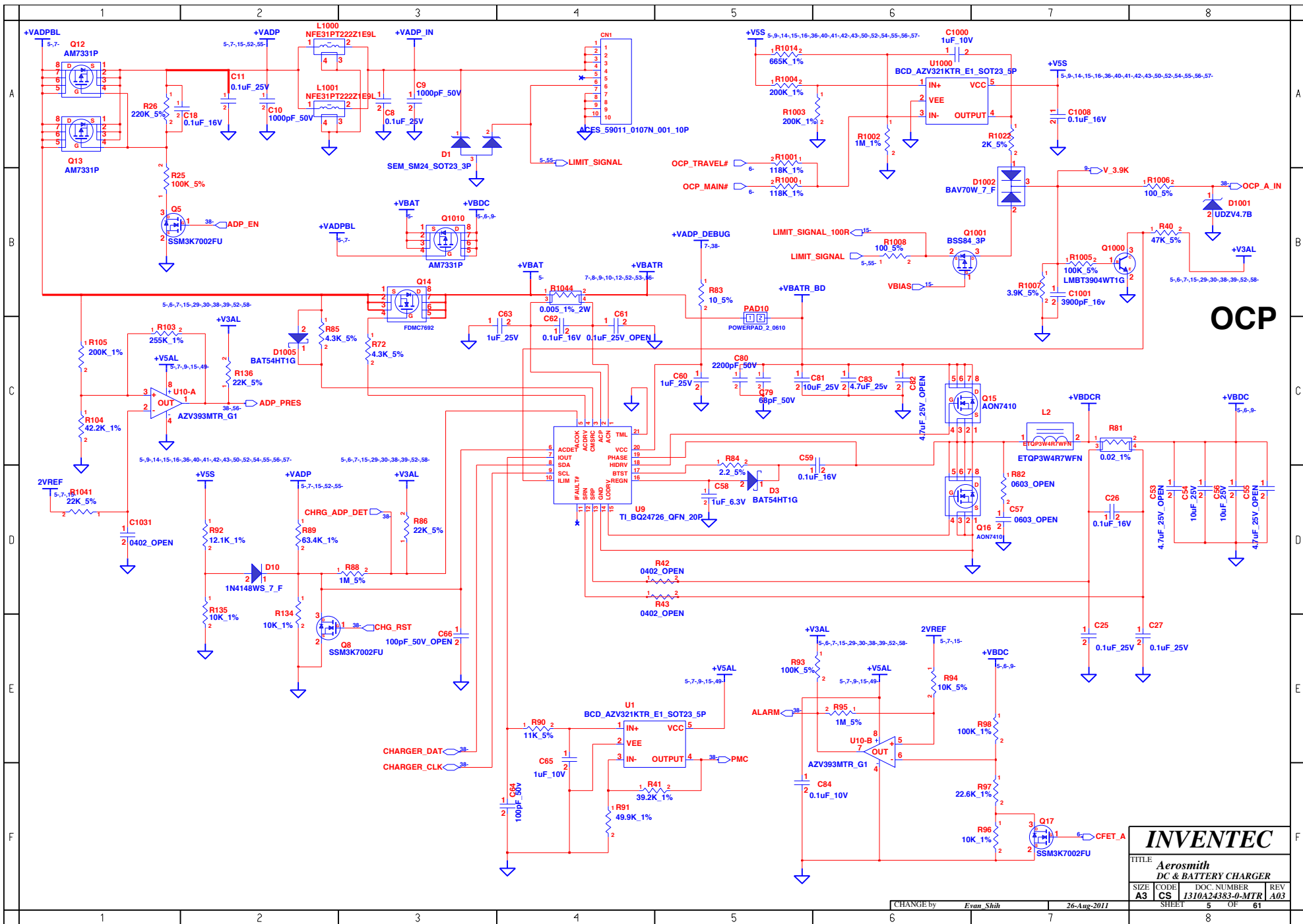

www.vinafix.vn

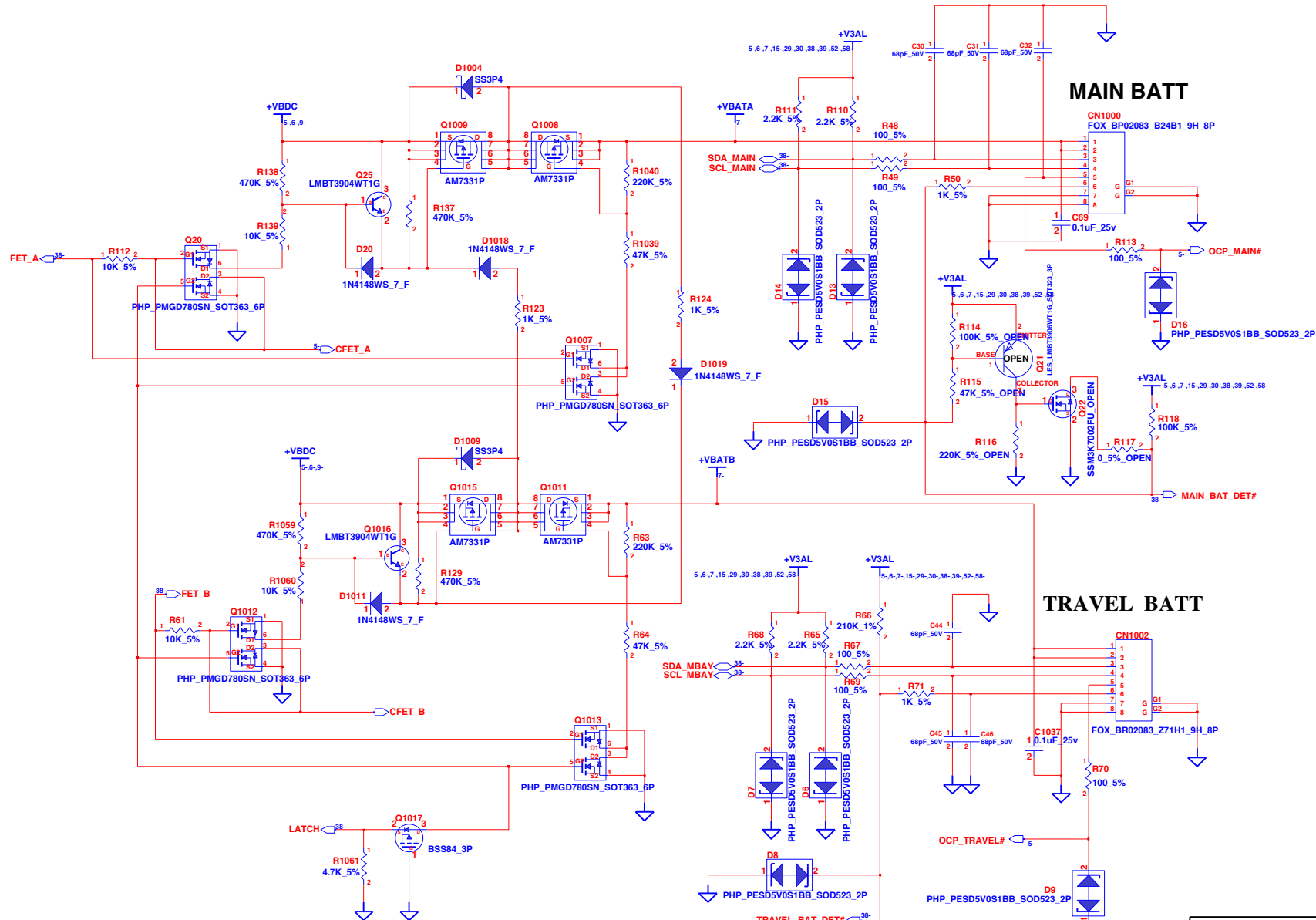

INVENTEC			
TITLE Aerosmith SELECT & BATTERY CONN			
SIZE A3	CODE CS	DOC NUMBER 1310A24383-0-MTR	REV A03
CHANGE by Evan Shih		26-Aug-2011	
SHEET 6		OF 61	

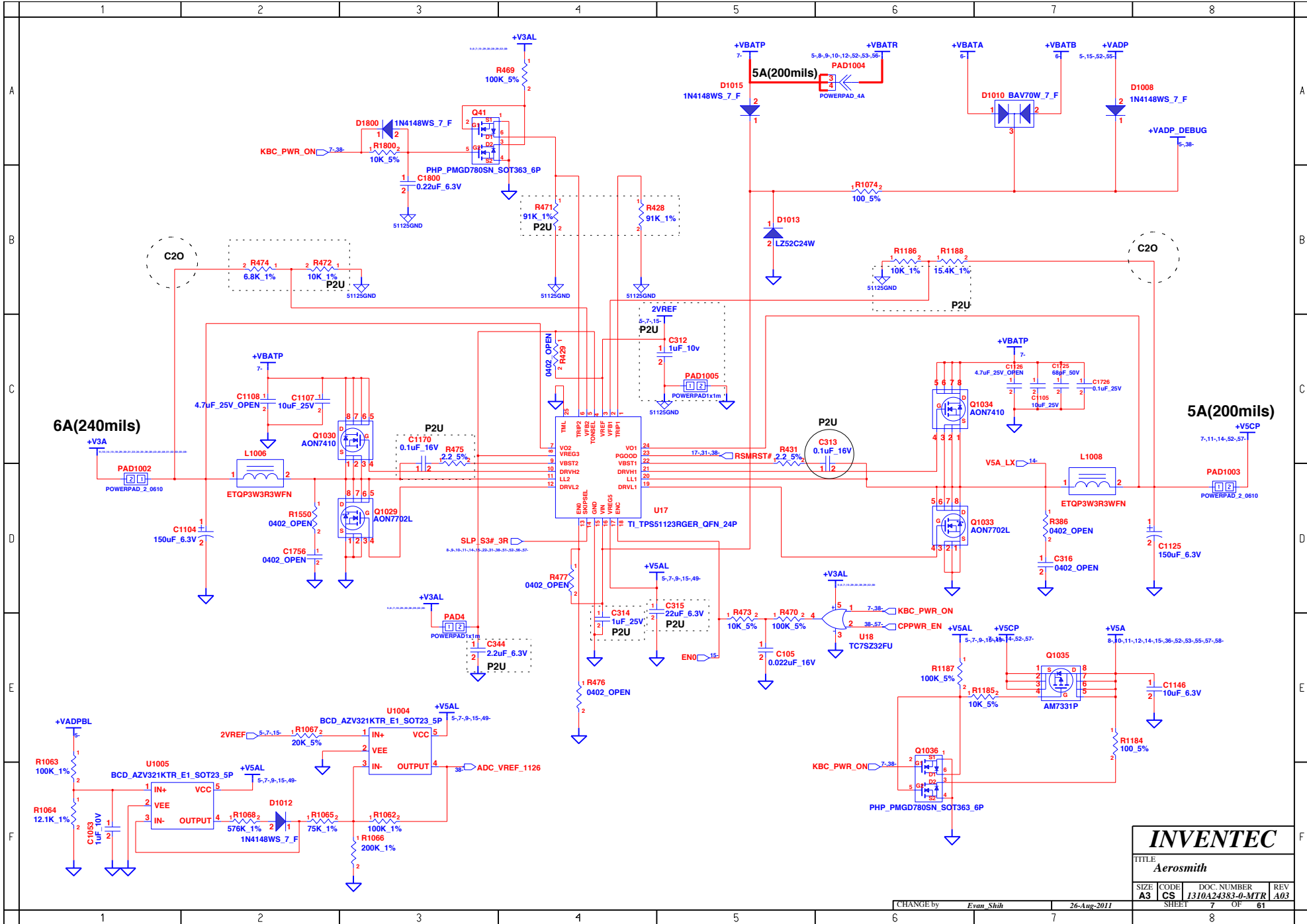

INVENTEC			
TITLE			
Aerosmith			
SIZE	CODE	DOC. NUMBER	REV
A3	CS	1310A24383-0-MTR	A03
CHANGE by		26-Aug-2011	
Evan Shih		7 OF 81	

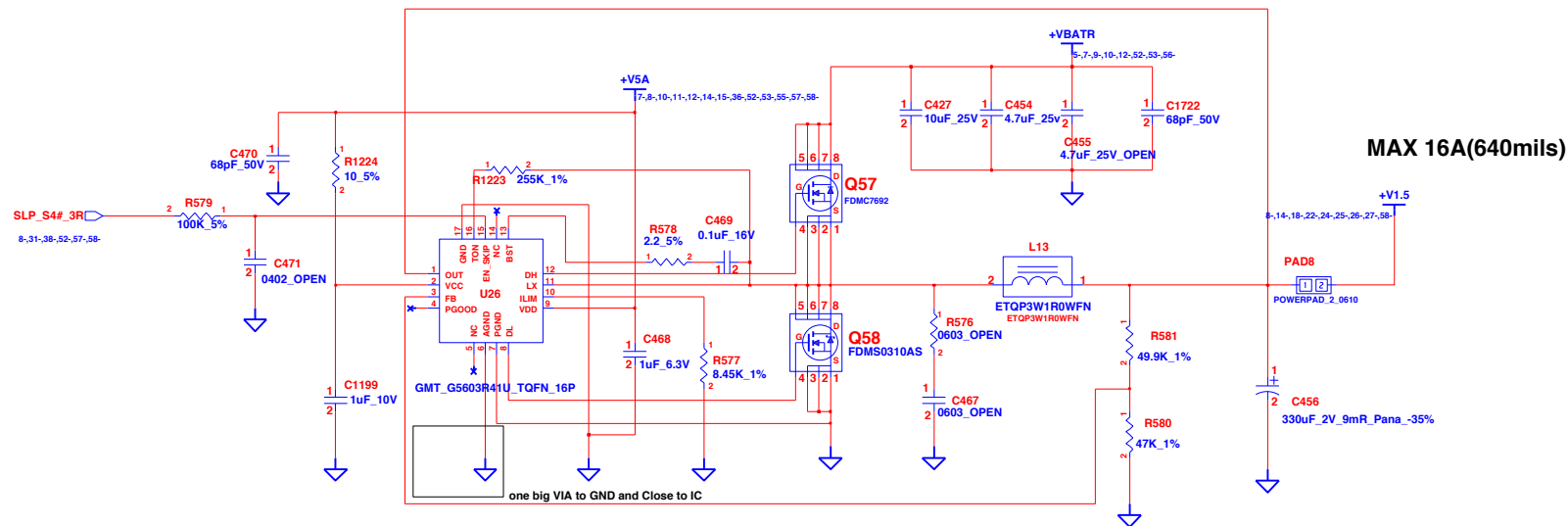

MAX 16A(640mils)

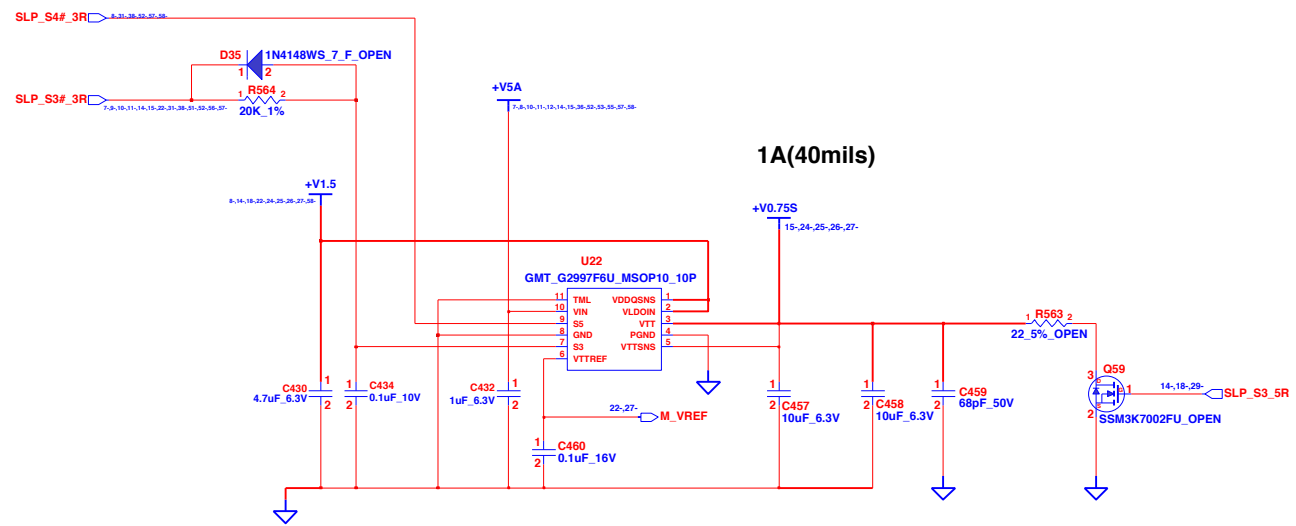

1A(40mils)

NOTE: DDR3 REGULATOR

INVENTEC			
TITLE: Aerosmith			
SYSTEM POWER(+V1.5/+V0.75S)			
SIZE	CODE	DOC. NUMBER	REV
A3	CS	1310A24383-0-MTR	A03
CHANGE by		Evon Shih	26-Aug-2011
SHEET		8	OF 61

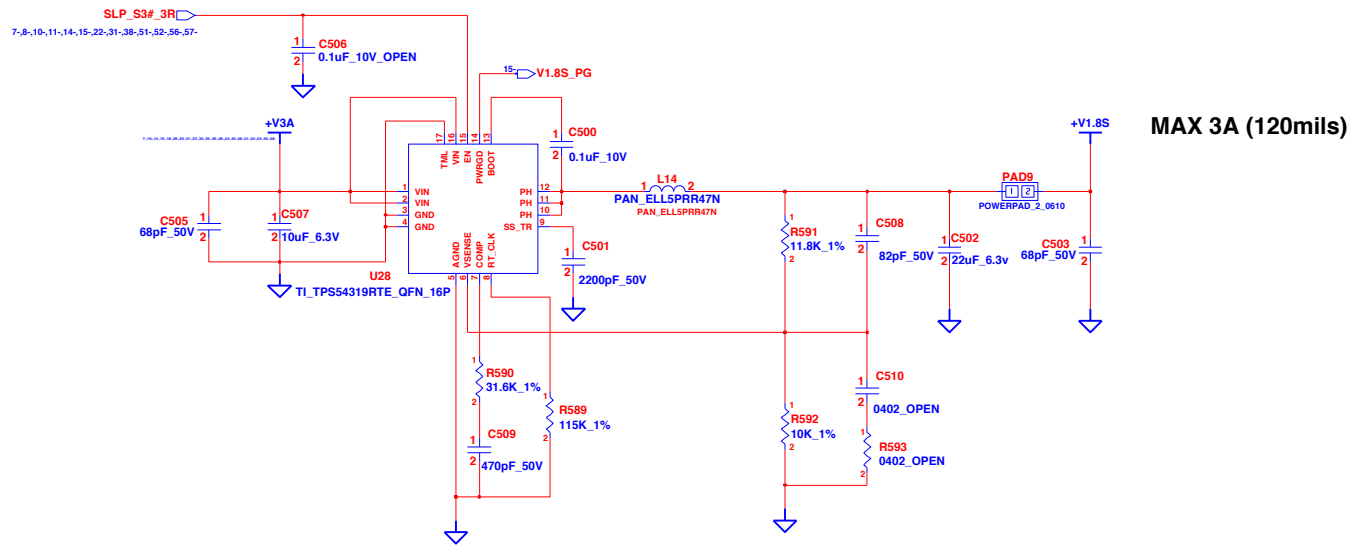

Turbo Boost

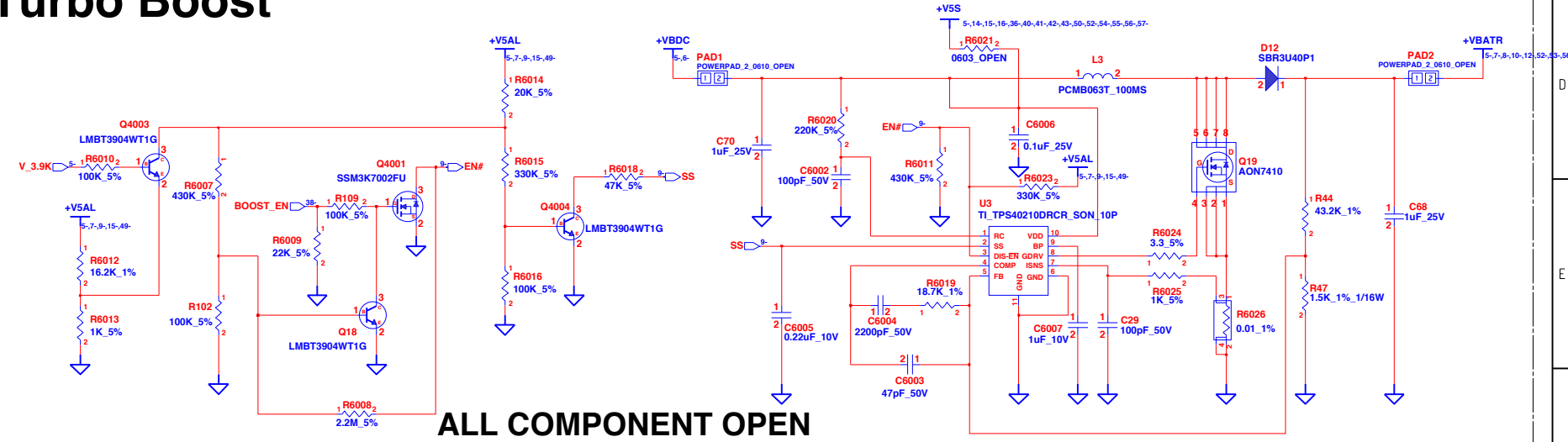

INVENTEC			
TITLE Aerosmith SYSTEM POWER(+V1.8S/Turbo Boost)			
SIZE A3	CODE CS	DOC. NUMBER 1310A24383-0-MTR	REV A03
CHANGE by <i>Evan Shih</i>		26-Aug-2011	
SHEET 9		OF 61	

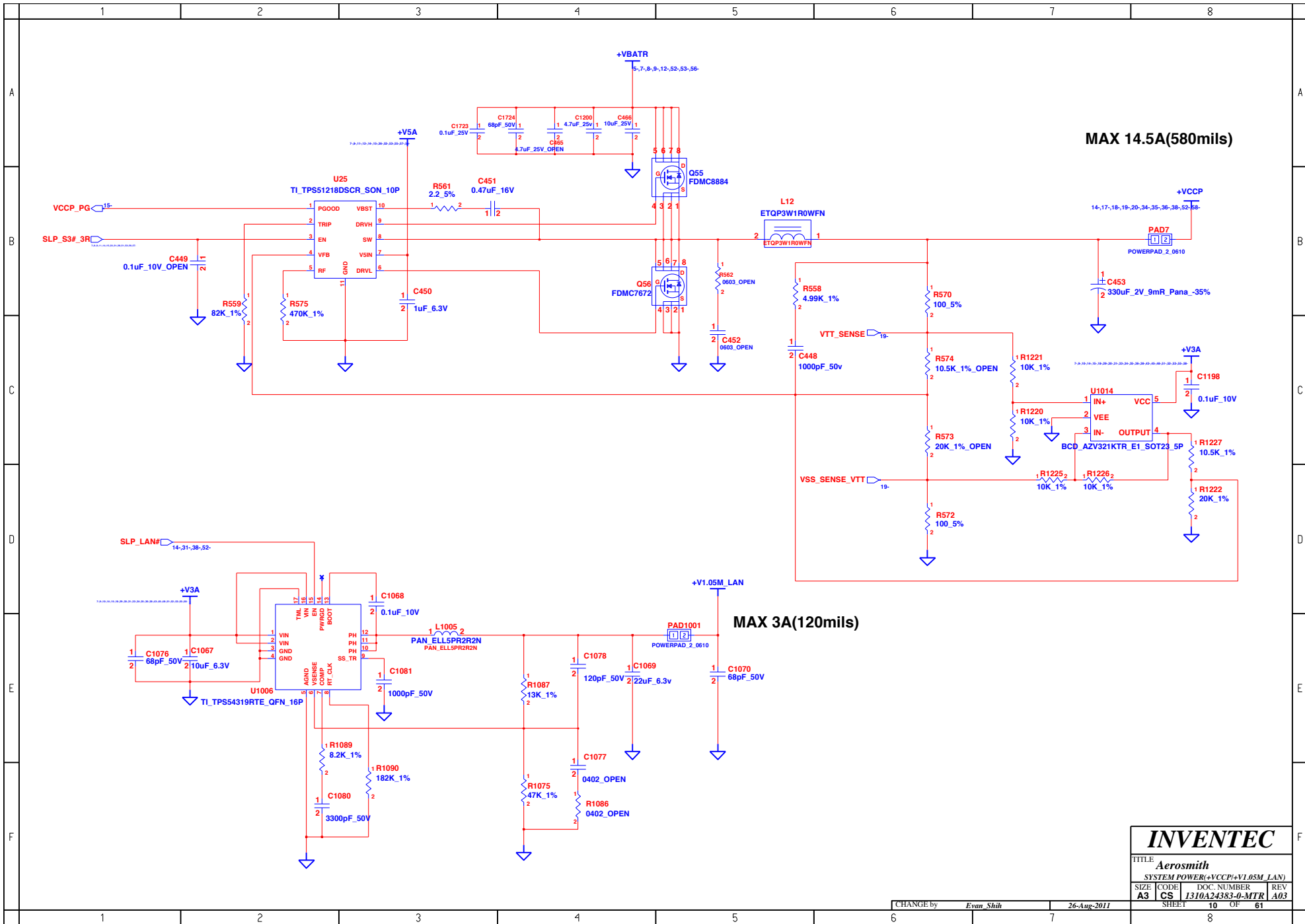

MAX 14.5A(580mils)

MAX 3A(120mils)

INVENTEC			
TITLE Aerosmith			
SYSTEM POWER(+VCCP)+V1.05M_LAN)			
SIZE A3	CODE CS	DOC. NUMBER 1310A24383-0-MTR	REV A03
CHANGE by <i>Evon Shih</i>		26-Aug-2011	
SHEET 10		OF 61	

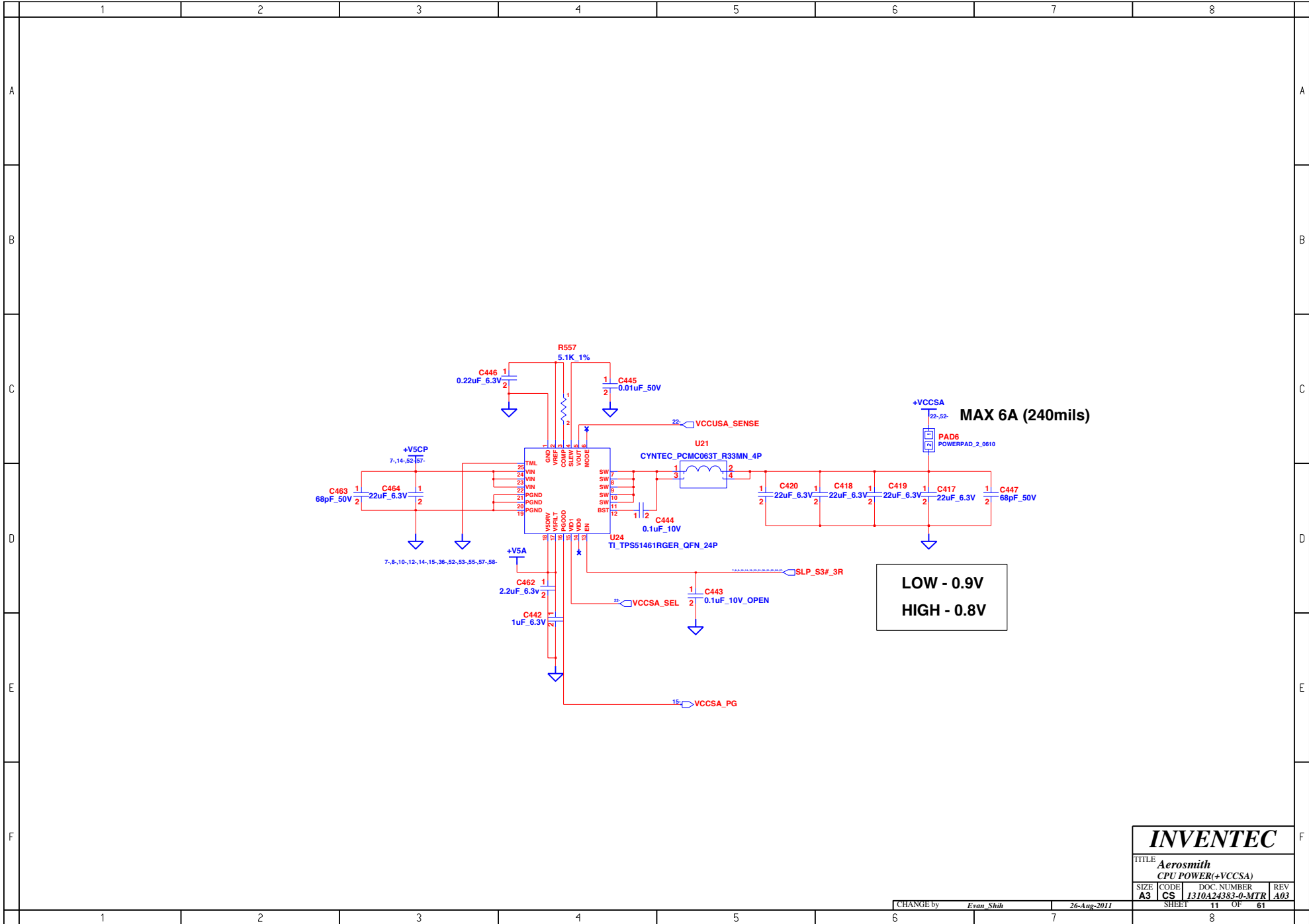

LOW - 0.9V
HIGH - 0.8V

INVENTEC

TITLE: **Aerosmith CPU POWER(+VCCSA)**

SIZE	CODE	DOC. NUMBER	REV
A3	CS	1310A24383-0-MTR	A03

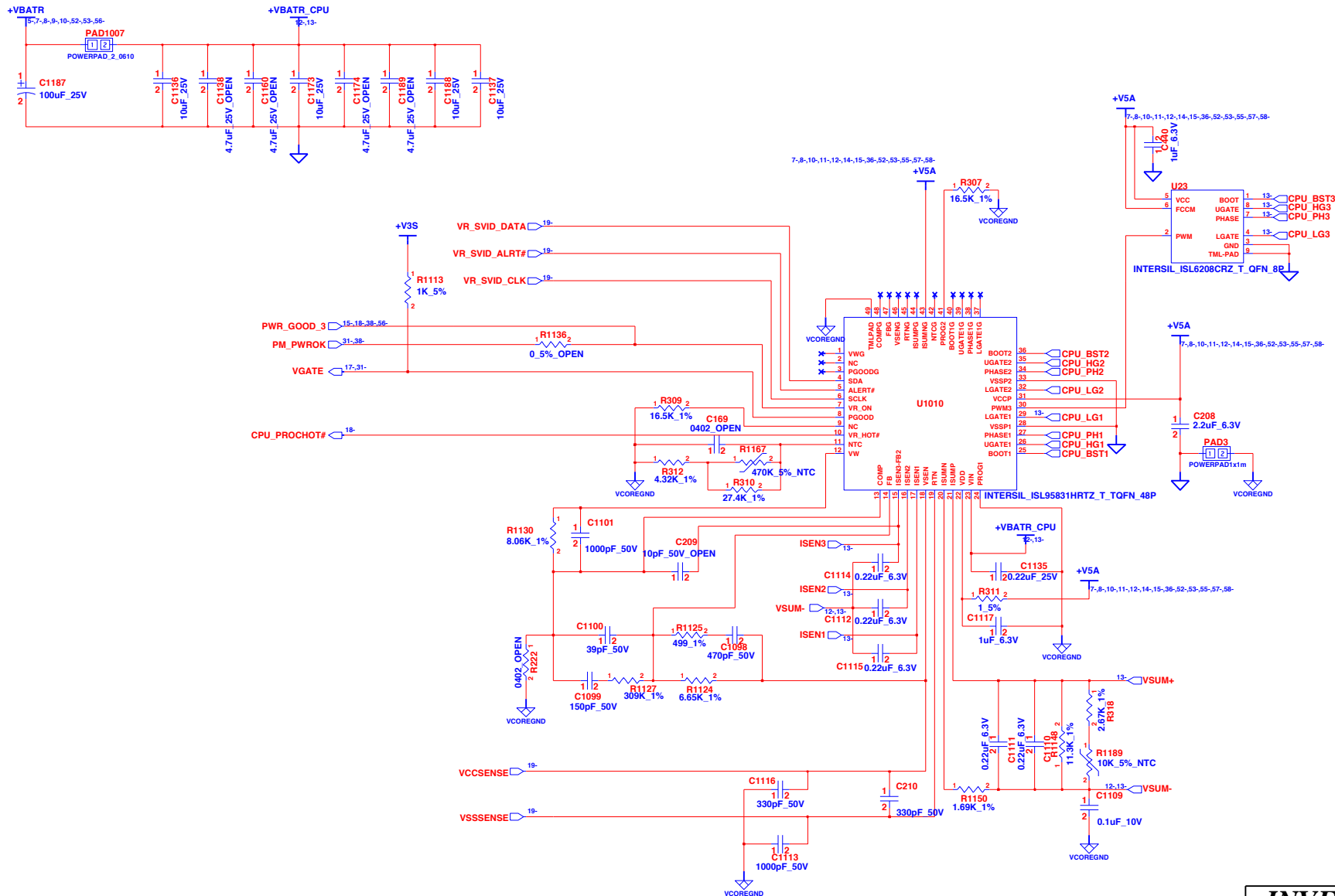

INVENTEC			
TITLE Aerosmith CPU POWER(+VCC_CORE)			
SIZE A3	CODE CS	DOC. NUMBER 1310A24383-0-MTR	REV A03
CHANGE by <i>Evan Shih</i>		26-Aug-2011	
SHEET 12		OF 61	

VCC_CORE (SV 35W-->MAX 53A)
 (Quad 45W-->MAX 94A)
 (XE 55W-->MAX 97A)

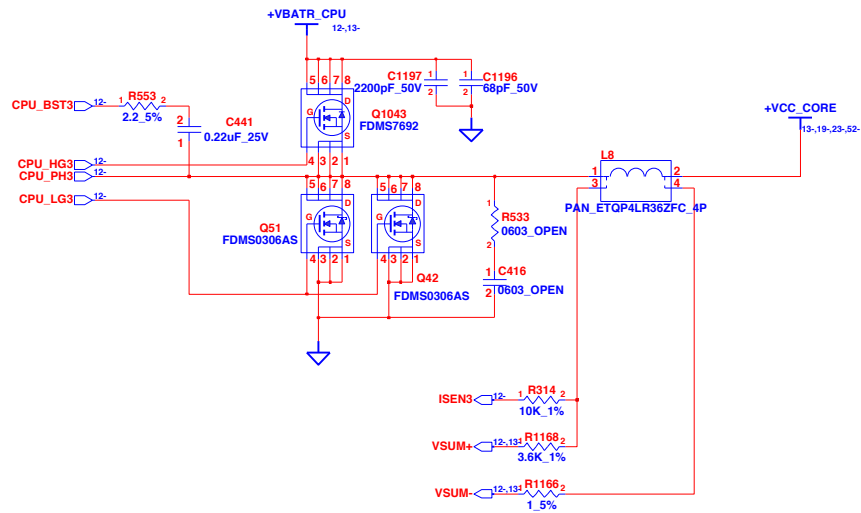
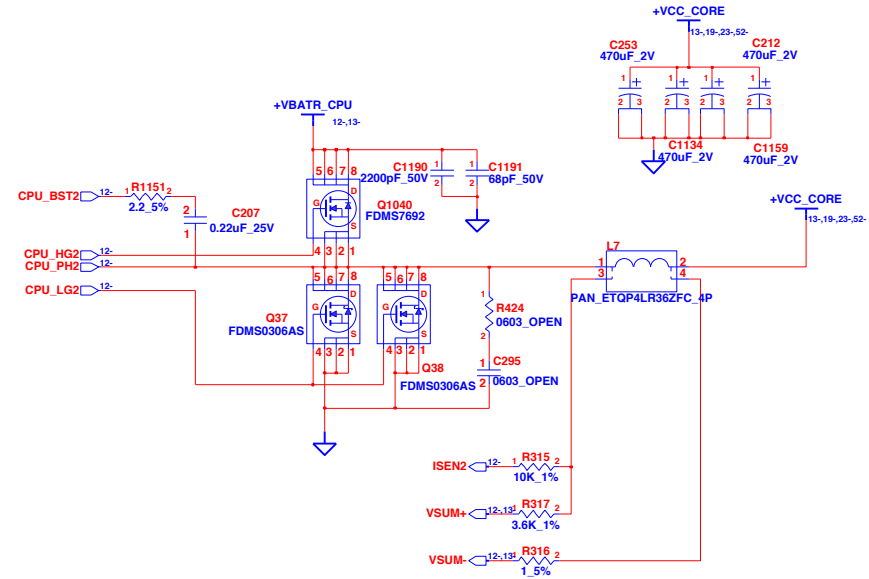
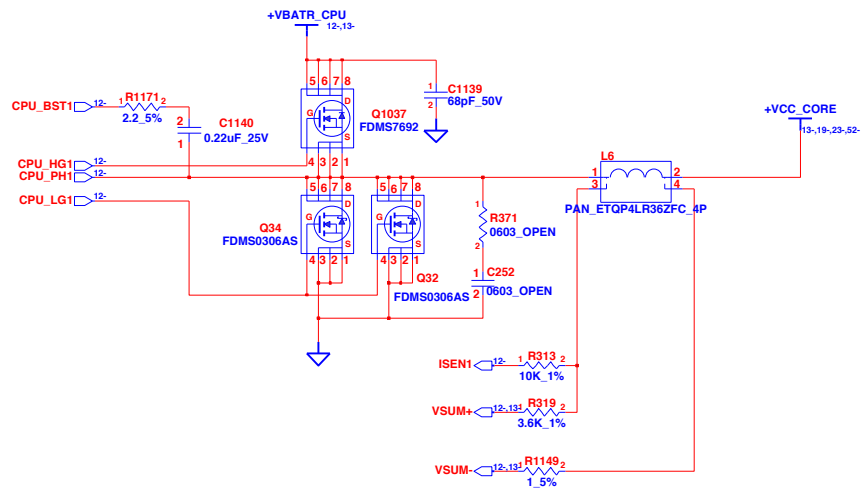

INVENTEC

TITLE			
Aerosmith CPU POWER(+VCC_CORE)			
SIZE	CODE	DOC. NUMBER	REV
A3	CS	1310A24383-0-MTR	A03
CHANGE by		SHEET	OF
Evan Shih		13	61

26-Aug-2011

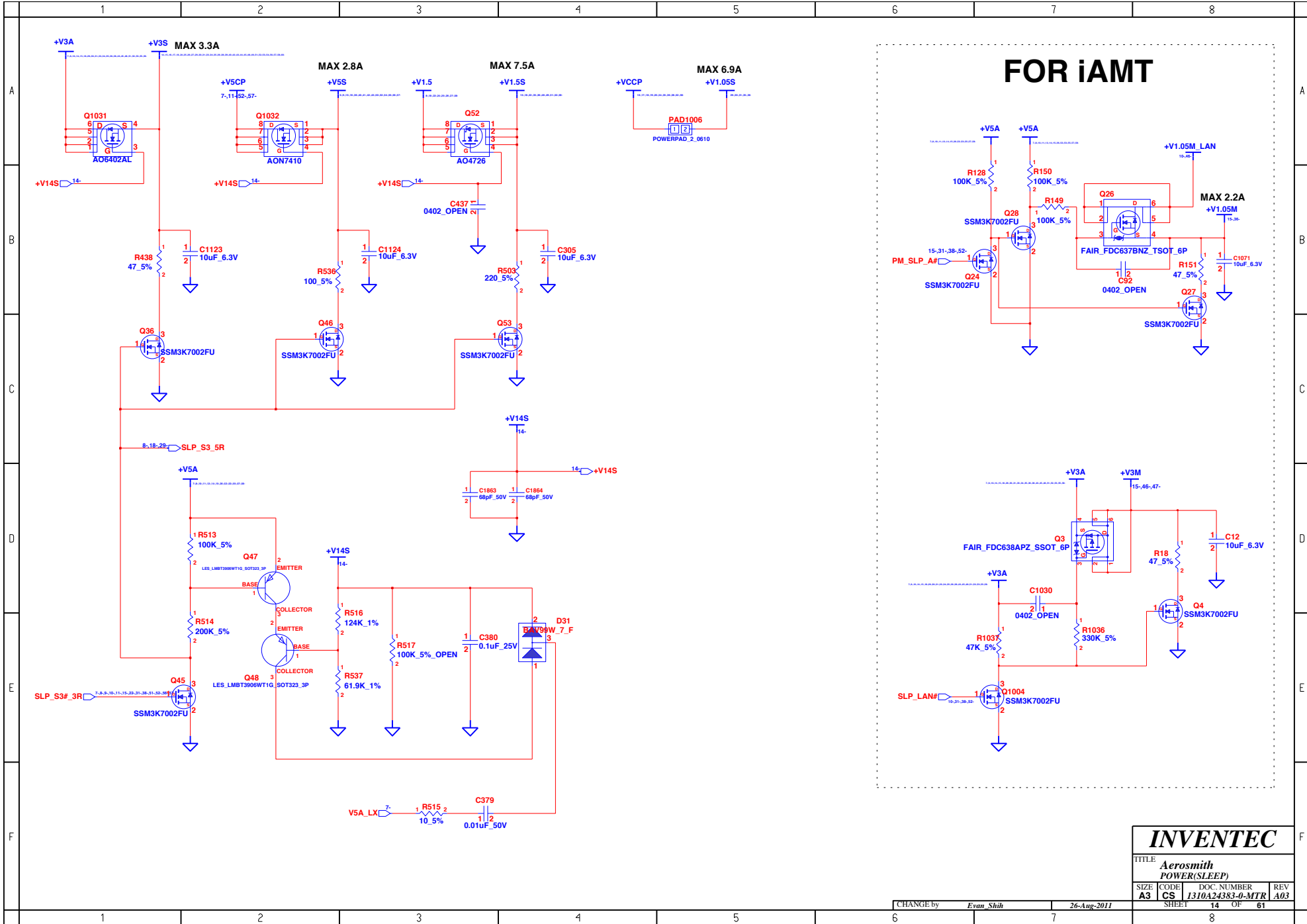

INVENTEC

TITLE			
Aerosmith POWER(SLEEP)			
SIZE	CODE	DOC. NUMBER	REV
A3	CS	I310A24383-0-MTR	A03
CHANGE by		SHEET	OF
Evan Shih		14	61

26-Aug-2011

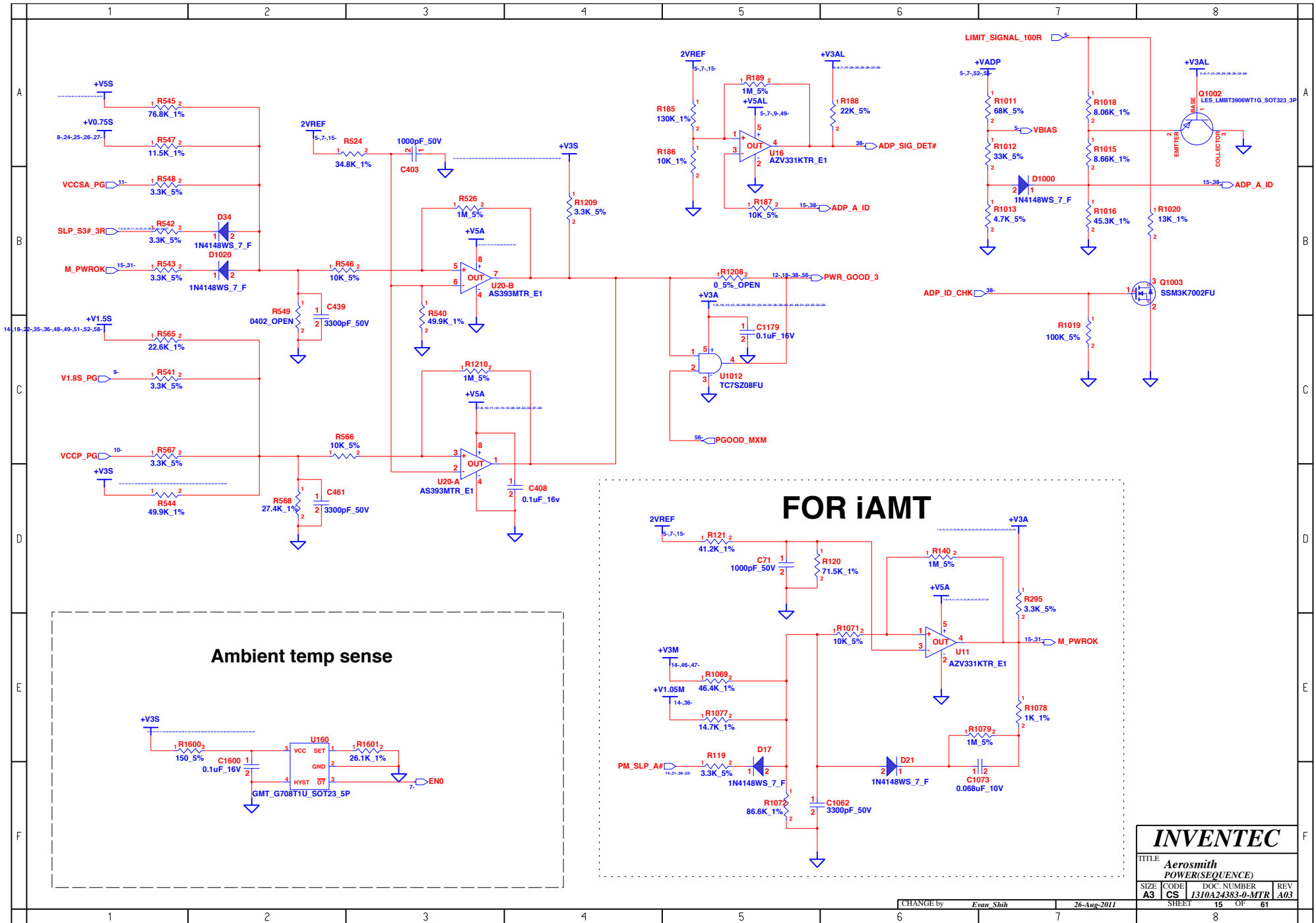

Ambient temp sense

FOR iAMT

INVENTEC			
TITLE Aerosmith POWER(SEQUENCE)			
SIZE A3	CODE CS	DOC. NUMBER I310A24383-0-MTR	REV A03
CHANGE by Evan Shih		26-Aug-2011	
SHEET 15		OF 61	

FAN

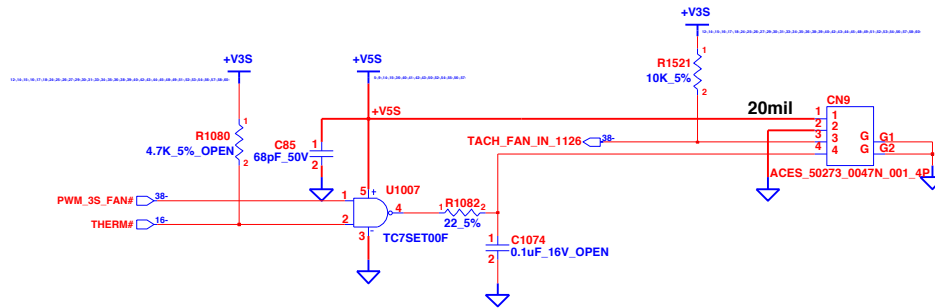

THERMAL SENSOR

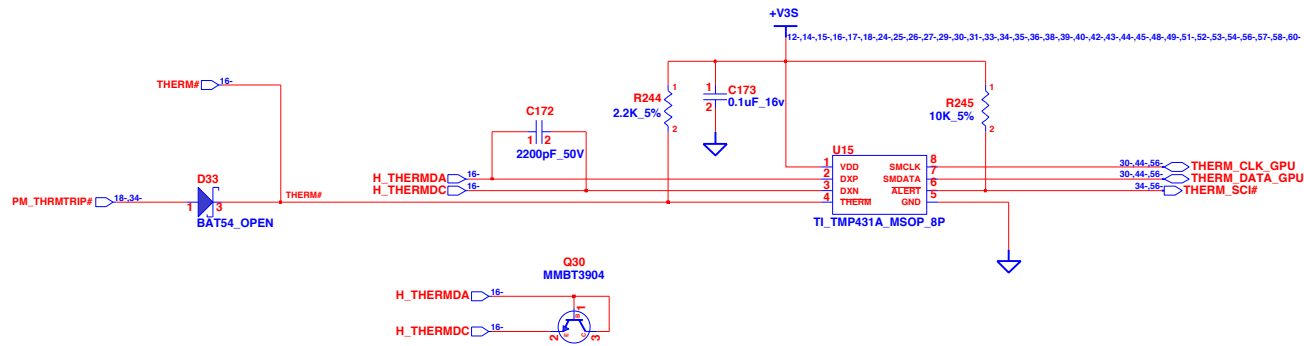

INVENTEC

TITLE			
Aerosmith			
THERMAL & FAN CONTROLLER			
SIZE	CODE	DOC. NUMBER	REV
A3	CS	1310A24383-0-MTR	A03
SHEET		OF	
16		61	

CHANGE by *Evon Shih* 26-Aug-2011

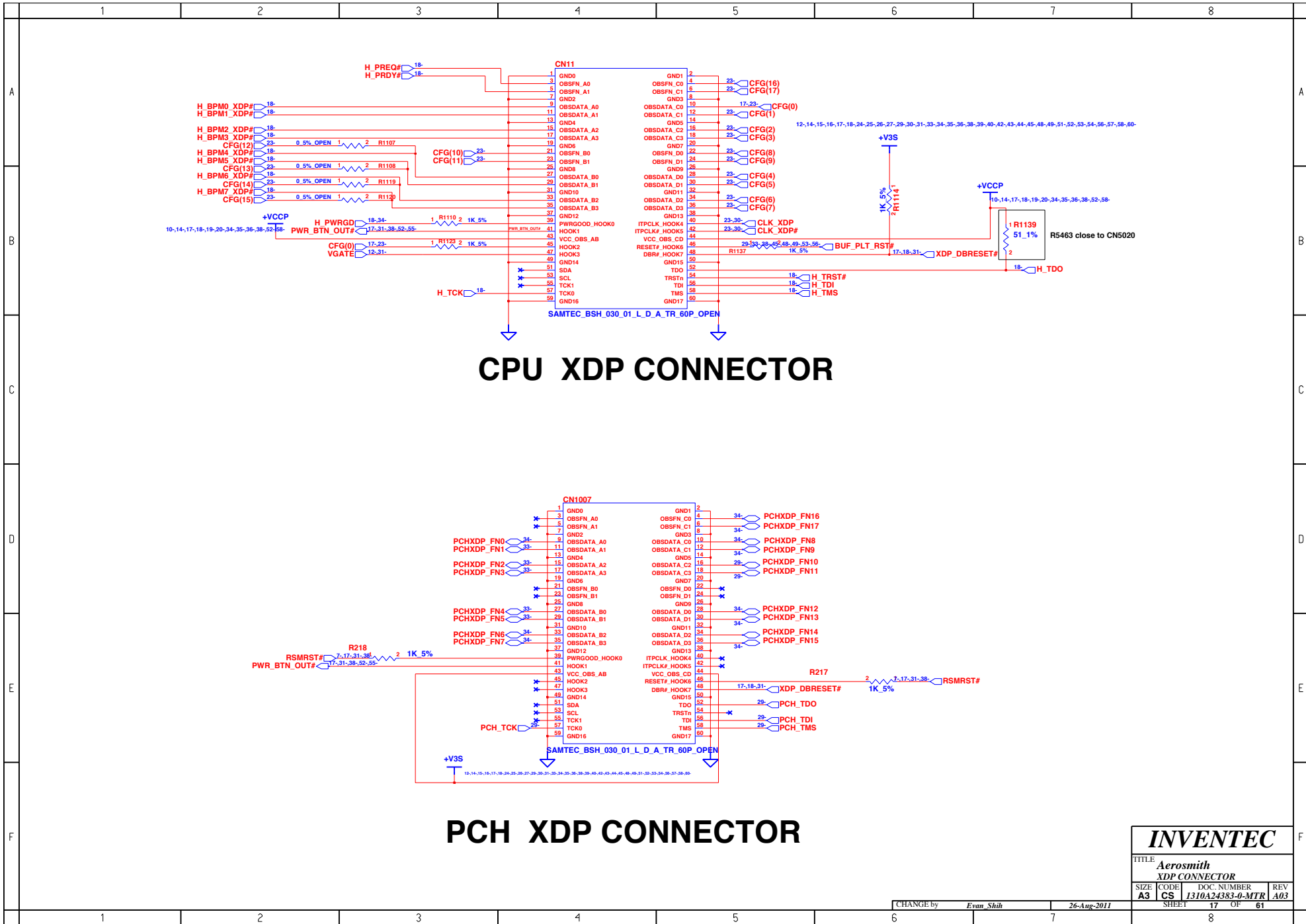

CPU XDP CONNECTOR

PCH XDP CONNECTOR

INVENTEC			
TITLE Aerosmith XDP CONNECTOR			
SIZE A3	CODE CS	DOC. NUMBER 1310A24383-0-MTR	REV A03
CHANGE by <i>Evan Shih</i>		26-Aug-2011	
SHEET 17		OF 61	

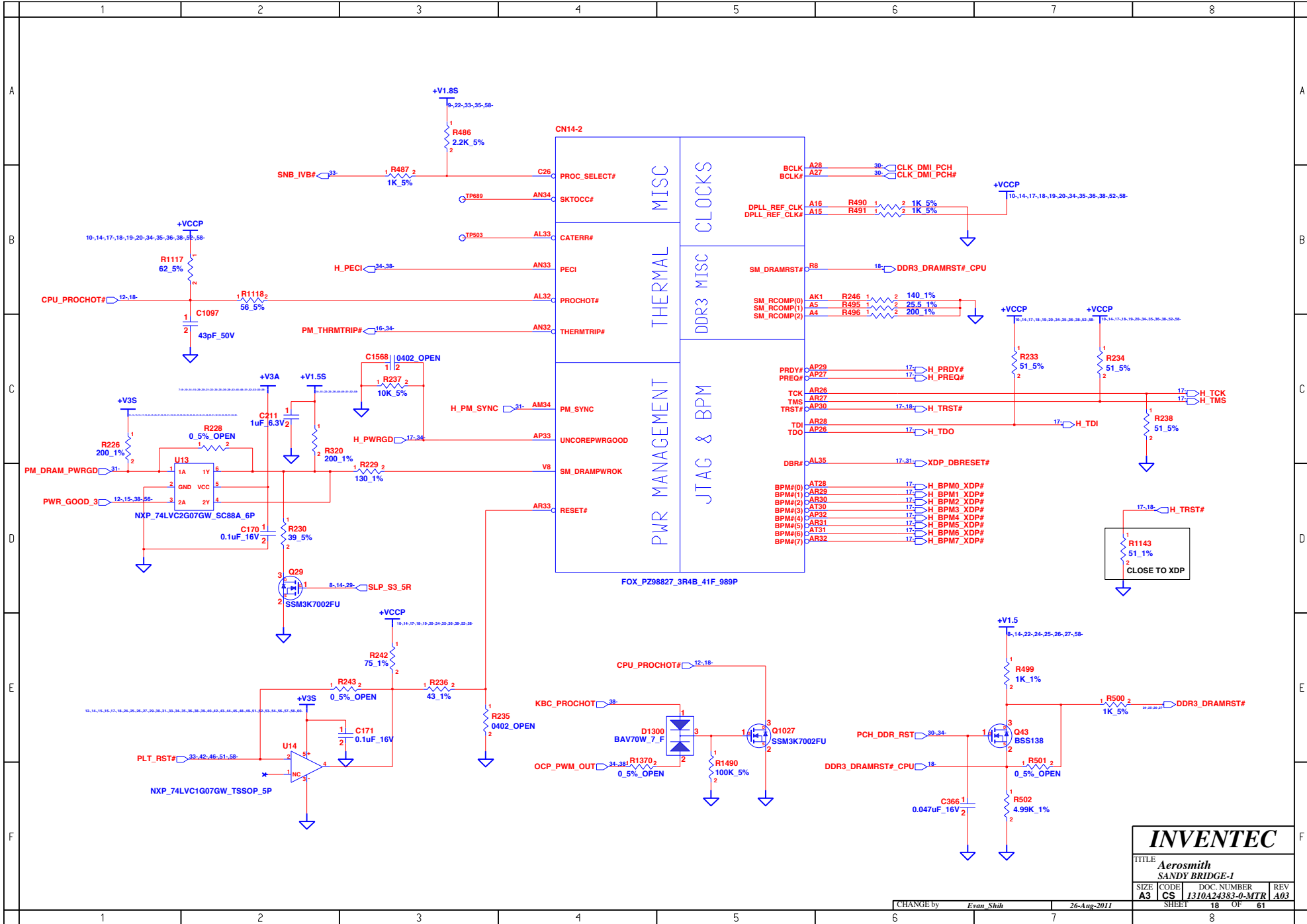

INVENTEC			
TITLE Aerosmith SANDY BRIDGE-1			
SIZE A3	CODE CS	DOC. NUMBER 1310A24383-0-MTR	REV A03
CHANGE by Evan Shih		26-Aug-2011	
SHEET 18		OF 61	

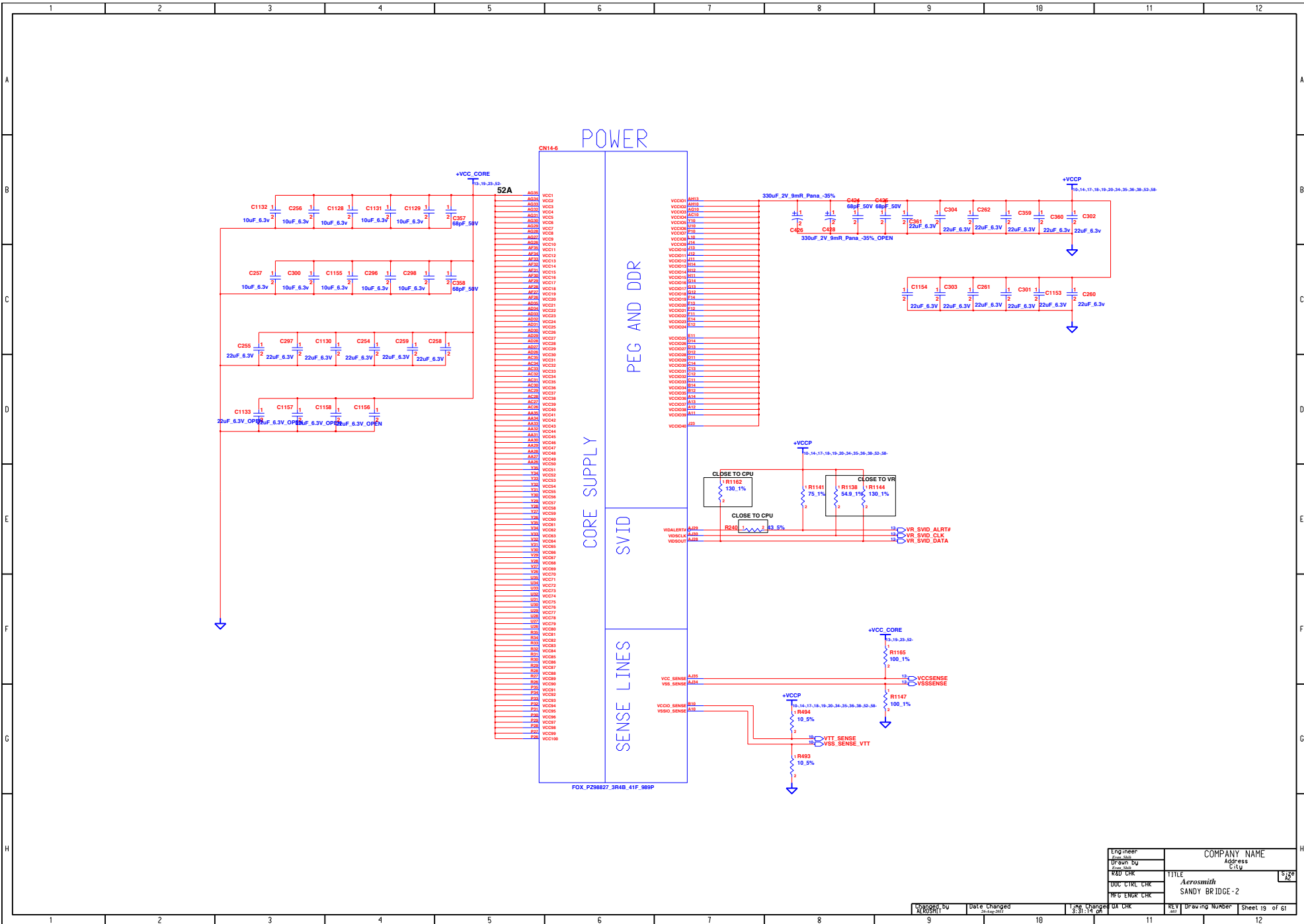

Engineer	COMPANY NAME
Drawn By	Address
Rev. No.	City
DATE CHK	TITLE
DATE CHK	Acrosmith
DATE CHK	SANDY BRIDGE-2
DATE CHK	REV
DATE CHK	Drawing Number
DATE CHK	Sheet 19 of 61

Date Changed
 Date Changed
 Date Changed

CLOSED TO CPU

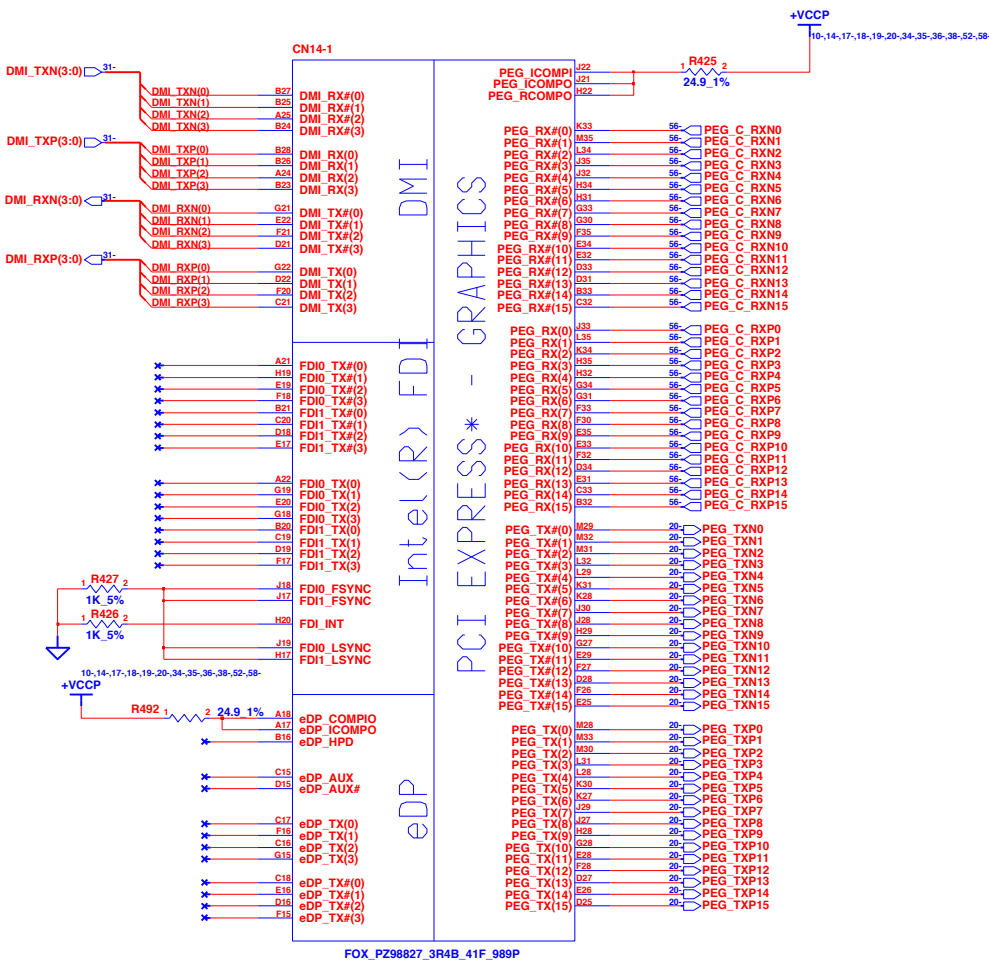

PEG_TXP0	20-	C112	0.22uF 10V	56-	PEG_C_TXP0
PEG_TXP1	20-	C110	0.22uF 10V	56-	PEG_C_TXP1
PEG_TXP2	20-	C144	0.22uF 10V	56-	PEG_C_TXP2
PEG_TXP3	20-	C138	0.22uF 10V	56-	PEG_C_TXP3
PEG_TXP4	20-	C159	0.22uF 10V	56-	PEG_C_TXP4
PEG_TXP5	20-	C148	0.22uF 10V	56-	PEG_C_TXP5
PEG_TXP6	20-	C160	0.22uF 10V	56-	PEG_C_TXP6
PEG_TXP7	20-	C158	0.22uF 10V	56-	PEG_C_TXP7
PEG_TXP8	20-	C139	0.22uF 10V	56-	PEG_C_TXP8
PEG_TXP9	20-	C145	0.22uF 10V	56-	PEG_C_TXP9
PEG_TXP10	20-	C185	0.22uF 10V	56-	PEG_C_TXP10
PEG_TXP11	20-	C188	0.22uF 10V	56-	PEG_C_TXP11
PEG_TXP12	20-	C197	0.22uF 10V	56-	PEG_C_TXP12
PEG_TXP13	20-	C193	0.22uF 10V	56-	PEG_C_TXP13
PEG_TXP14	20-	C194	0.22uF 10V	56-	PEG_C_TXP14
PEG_TXP15	20-	C187	0.22uF 10V	56-	PEG_C_TXP15
PEG_TXN0	20-	C114	0.22uF 10V	56-	PEG_C_TXN0
PEG_TXN1	20-	C111	0.22uF 10V	56-	PEG_C_TXN1
PEG_TXN2	20-	C140	0.22uF 10V	56-	PEG_C_TXN2
PEG_TXN3	20-	C136	0.22uF 10V	56-	PEG_C_TXN3
PEG_TXN4	20-	C157	0.22uF 10V	56-	PEG_C_TXN4
PEG_TXN5	20-	C154	0.22uF 10V	56-	PEG_C_TXN5
PEG_TXN6	20-	C161	0.22uF 10V	56-	PEG_C_TXN6
PEG_TXN7	20-	C156	0.22uF 10V	56-	PEG_C_TXN7
PEG_TXN8	20-	C137	0.22uF 10V	56-	PEG_C_TXN8
PEG_TXN9	20-	C143	0.22uF 10V	56-	PEG_C_TXN9
PEG_TXN10	20-	C184	0.22uF 10V	56-	PEG_C_TXN10
PEG_TXN11	20-	C186	0.22uF 10V	56-	PEG_C_TXN11
PEG_TXN12	20-	C196	0.22uF 10V	56-	PEG_C_TXN12
PEG_TXN13	20-	C195	0.22uF 10V	56-	PEG_C_TXN13
PEG_TXN14	20-	C192	0.22uF 10V	56-	PEG_C_TXN14
PEG_TXN15	20-	C189	0.22uF 10V	56-	PEG_C_TXN15

INVENTEC

TITLE
Aerosmith
SANDY BRIDGE-3

SIZE A3	CODE CS	DOC. NUMBER 1310A24383-0-MTR	REV A03
------------	------------	---------------------------------	------------

CHANGE by: *Evon Shih* 26-Aug-2011

SHEET 20 OF 61

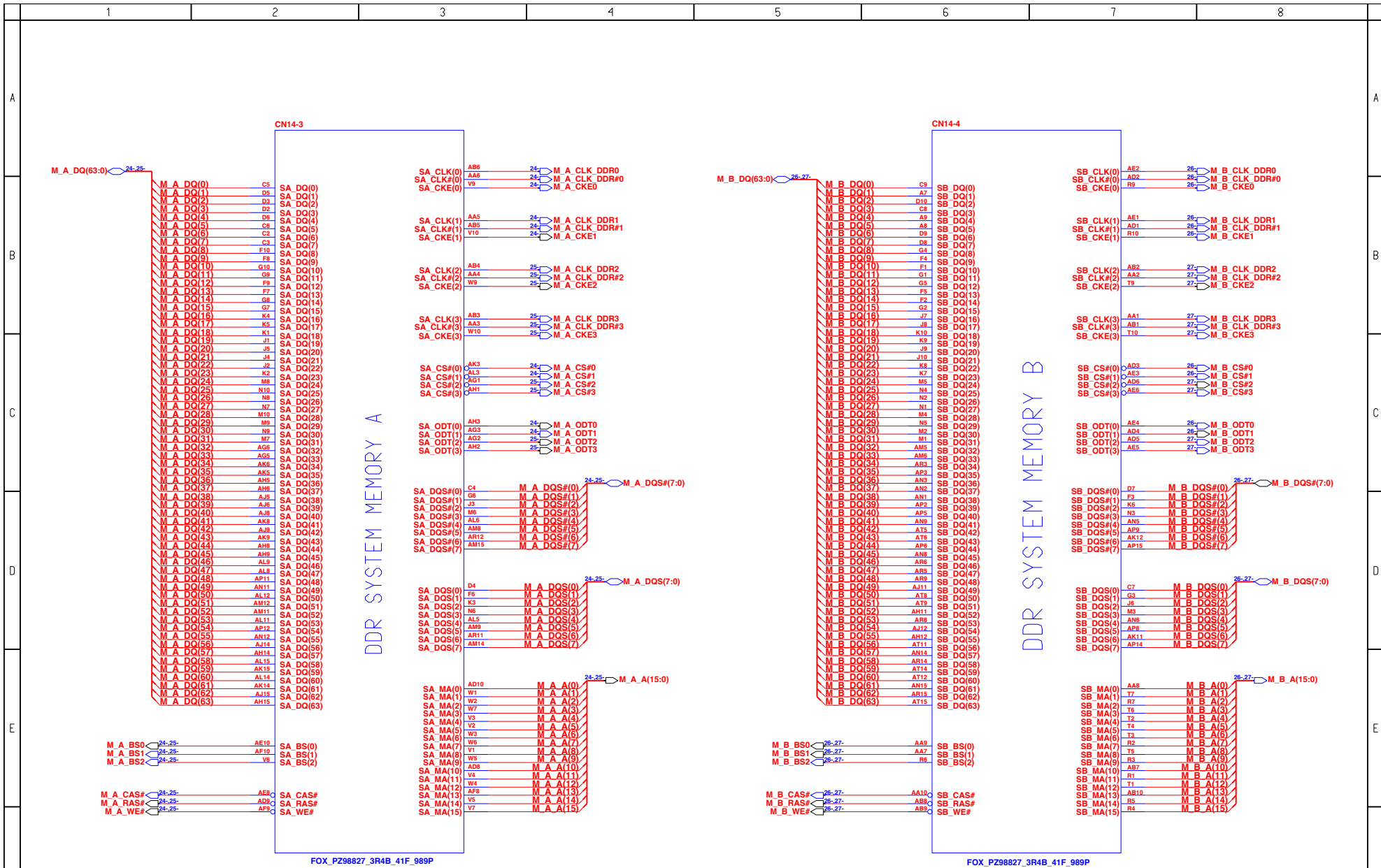

INVENTEC			
TITLE Aerosmith SANDY BRIDGE-4			
SIZE A3	CODE CS	DOC. NUMBER 1310A24383-0-MTR	REV A03
CHANGE by Evan Shih		26-Aug-2011	
SHEET 21		OF 61	

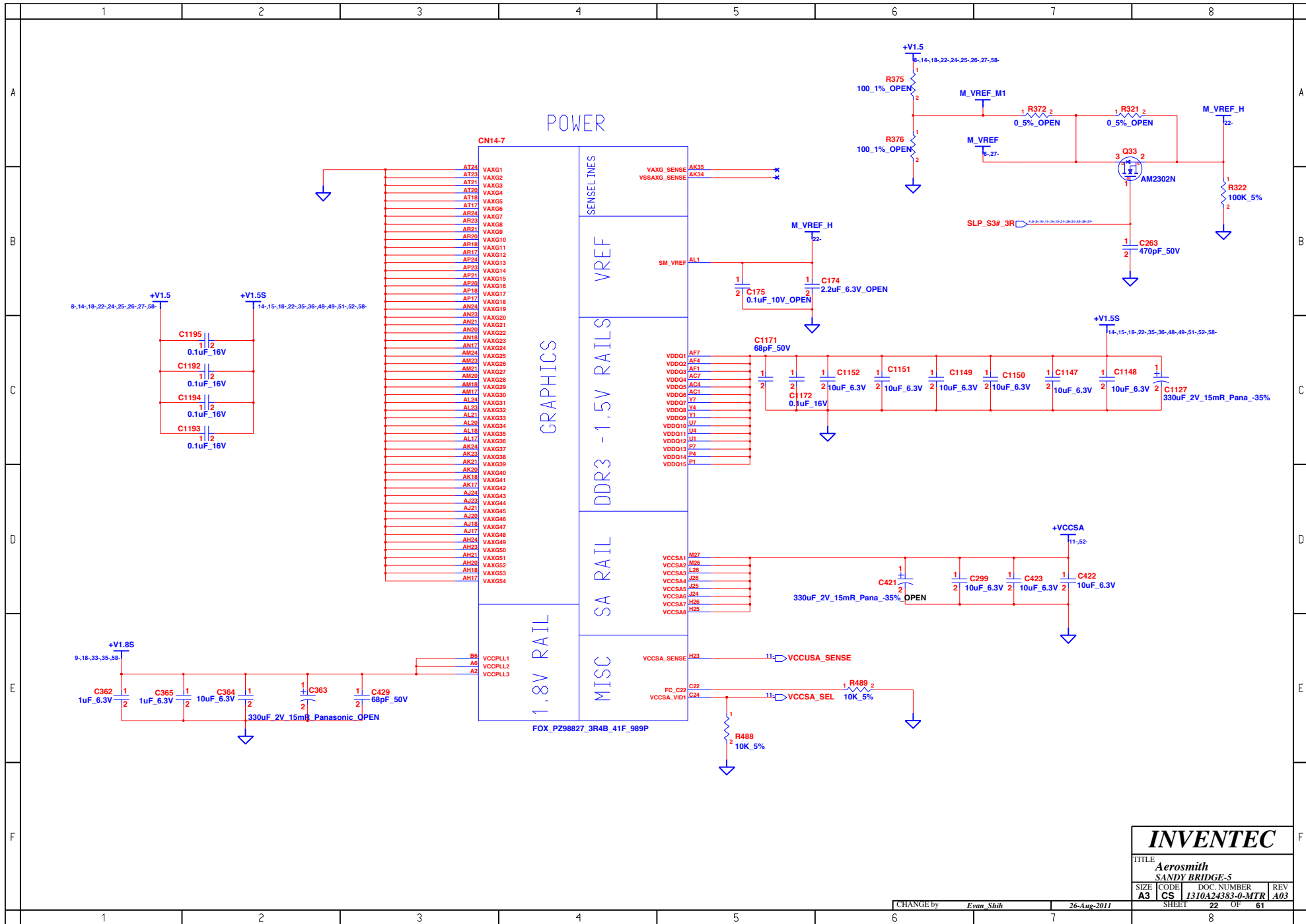

INVENTEC			
TITLE Aerosmith SANDY BRIDGE-5			
SIZE A3	CODE CS	DOC. NUMBER 1310A24383-0-MTR	REV A03
CHANGE by Evan Shih		26-Aug-2011	
SHEET 22		OF 61	

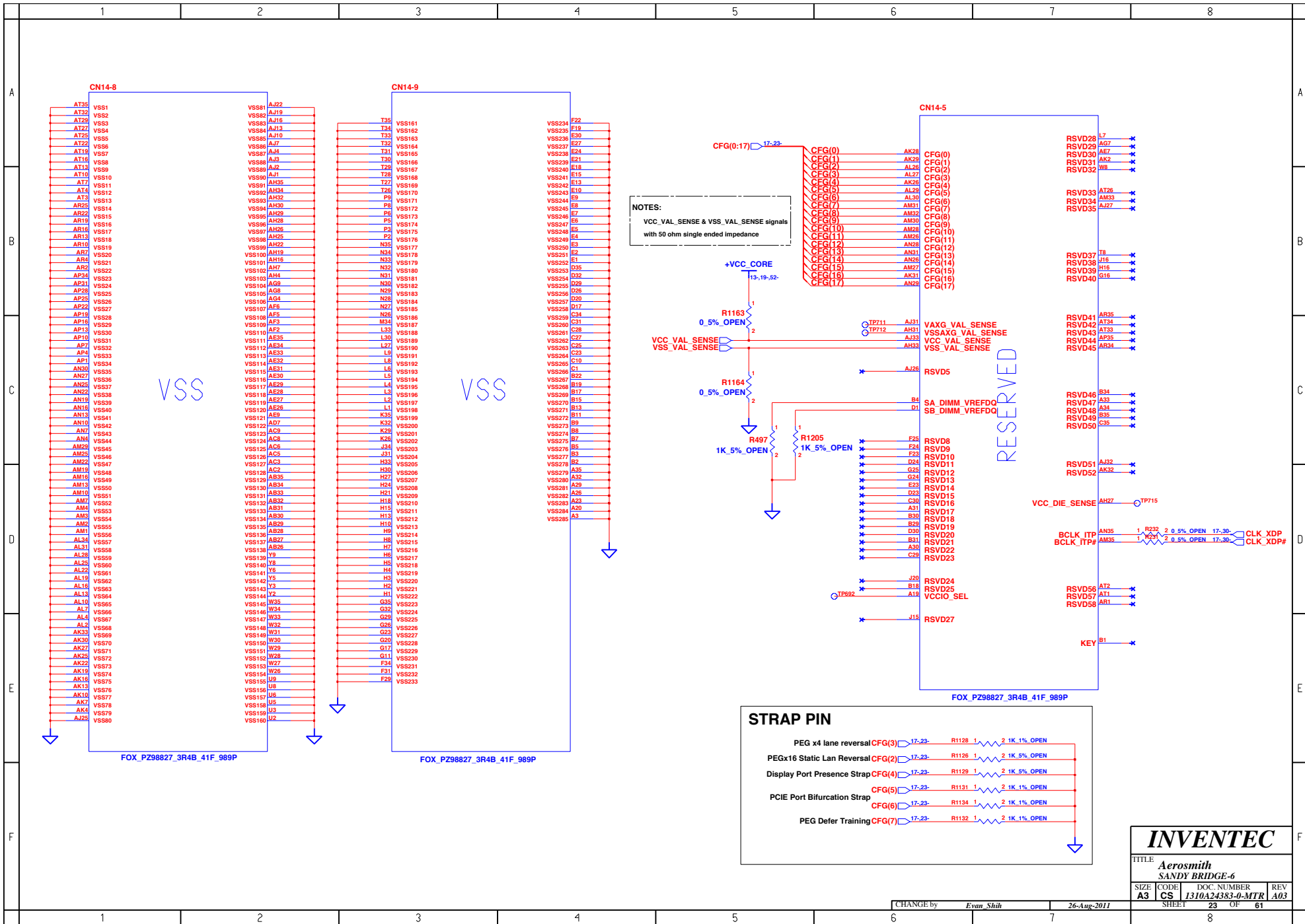

INVENTEC			
TITLE Aeromsmith SANDY BRIDGE-6			
SIZE A3	CODE CS	DOC. NUMBER 1310A24383-0-MTR	REV A03
CHANGE by Evan Shih		26-Aug-2011	
SHEET 23		OF 61	

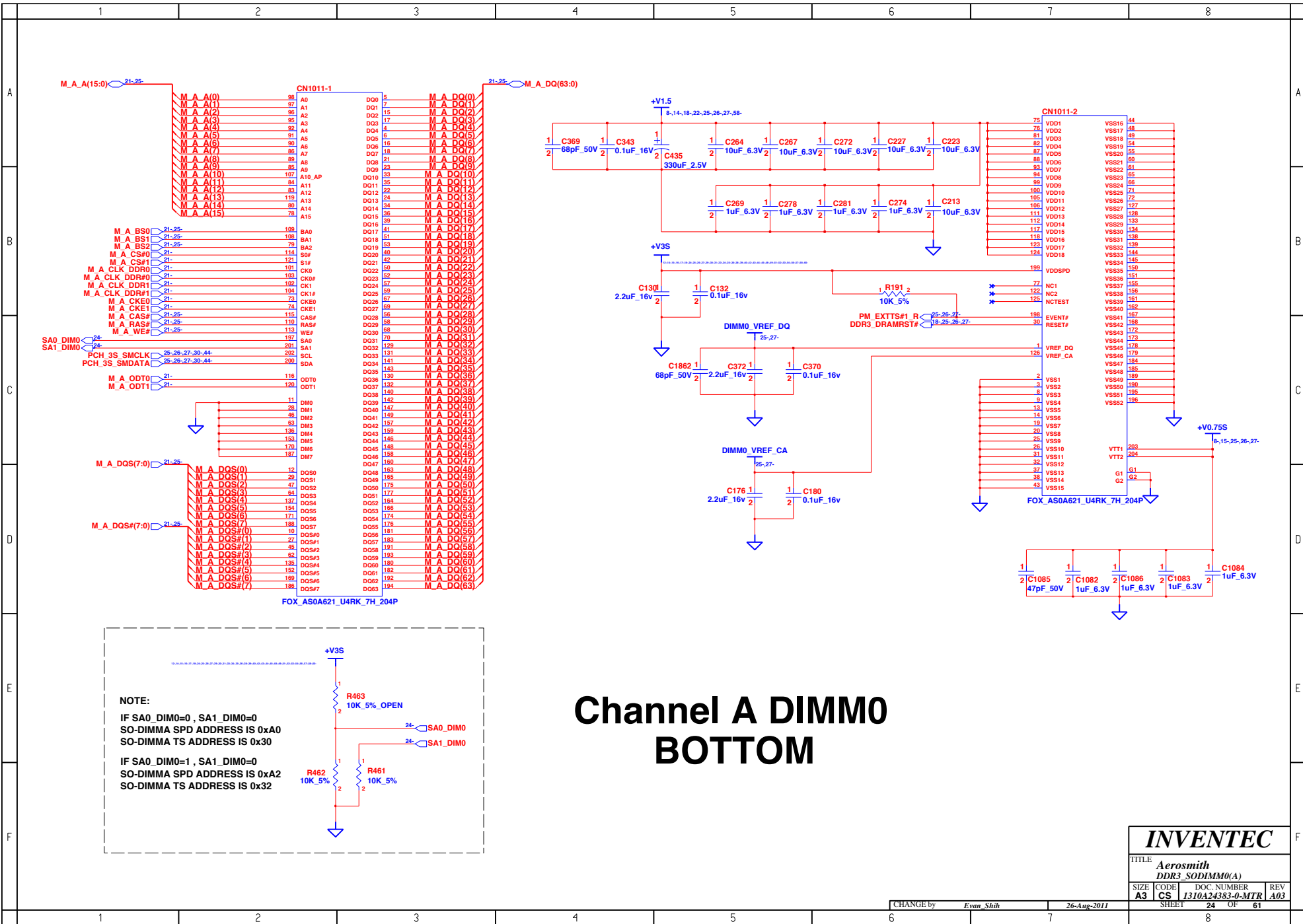

NOTE:

IF SA0_DIM0=0, SA1_DIM0=0
 SO-DIMMA SPD ADDRESS IS 0xA0
 SO-DIMMA TS ADDRESS IS 0x30

IF SA0_DIM0=1, SA1_DIM0=0
 SO-DIMMA SPD ADDRESS IS 0xA2
 SO-DIMMA TS ADDRESS IS 0x32

Channel A DIMM0 BOTTOM

INVENTEC			
TITLE Aerosmith DDR3_SODIMM0(A)			
SIZE A3	CODE CS	DOC. NUMBER 1310A24383-0-MTR	REV A03
CHANGE by Evan Shih		26-Aug-2011	
SHEET 24		OF 61	

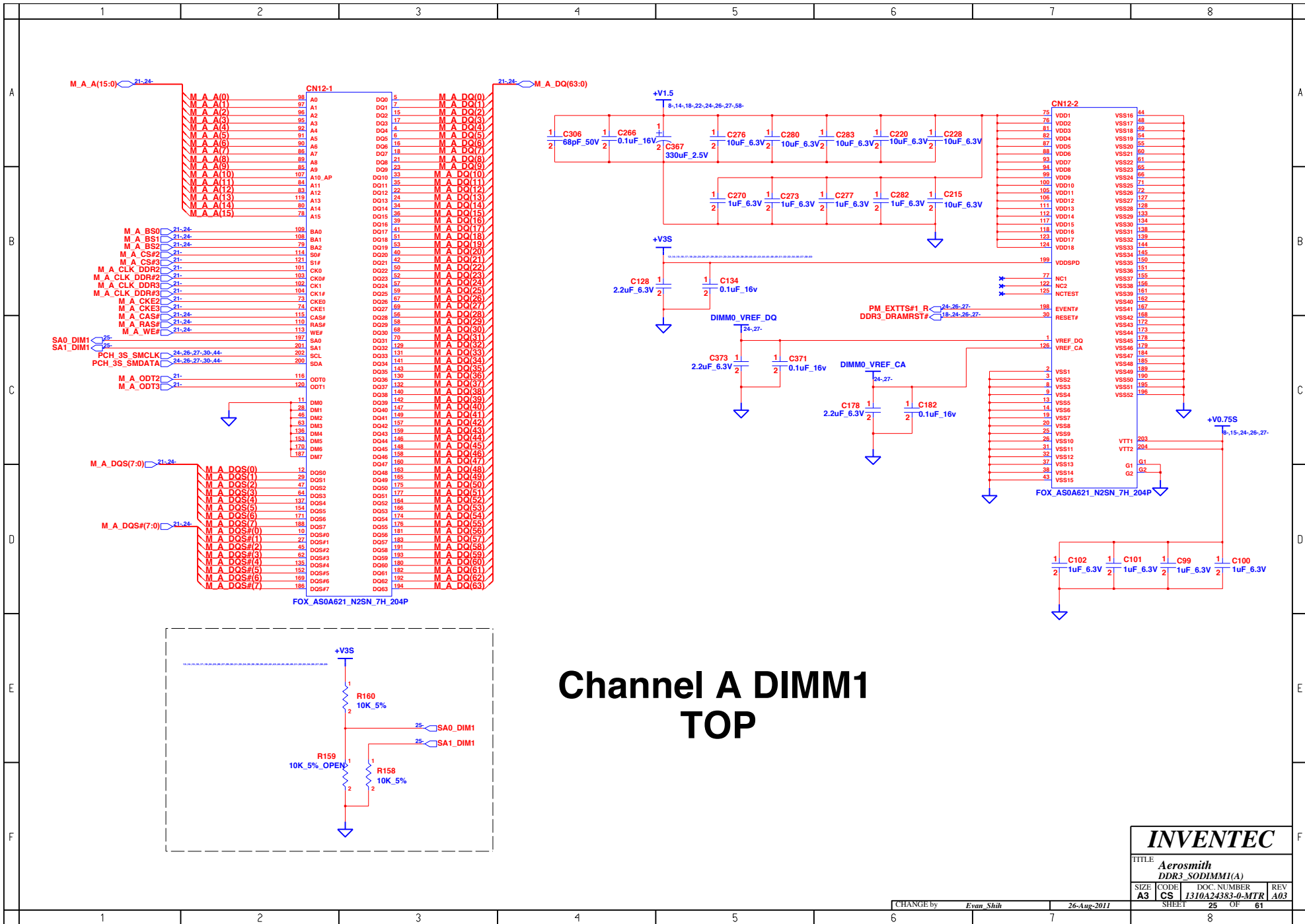

Channel A DIMM1 TOP

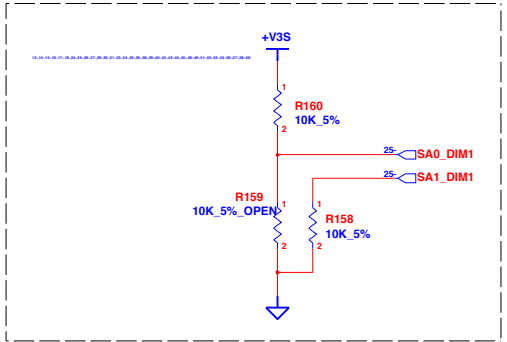

INVENTEC			
TITLE Aerosmith DDR3_SODIMM1(A)			
SIZE A3	CODE CS	DOC. NUMBER 1310A24383-0-MTR	REV A03
CHANGE by Evan Shih		26-Aug-2011	
SHEET 25		OF 61	

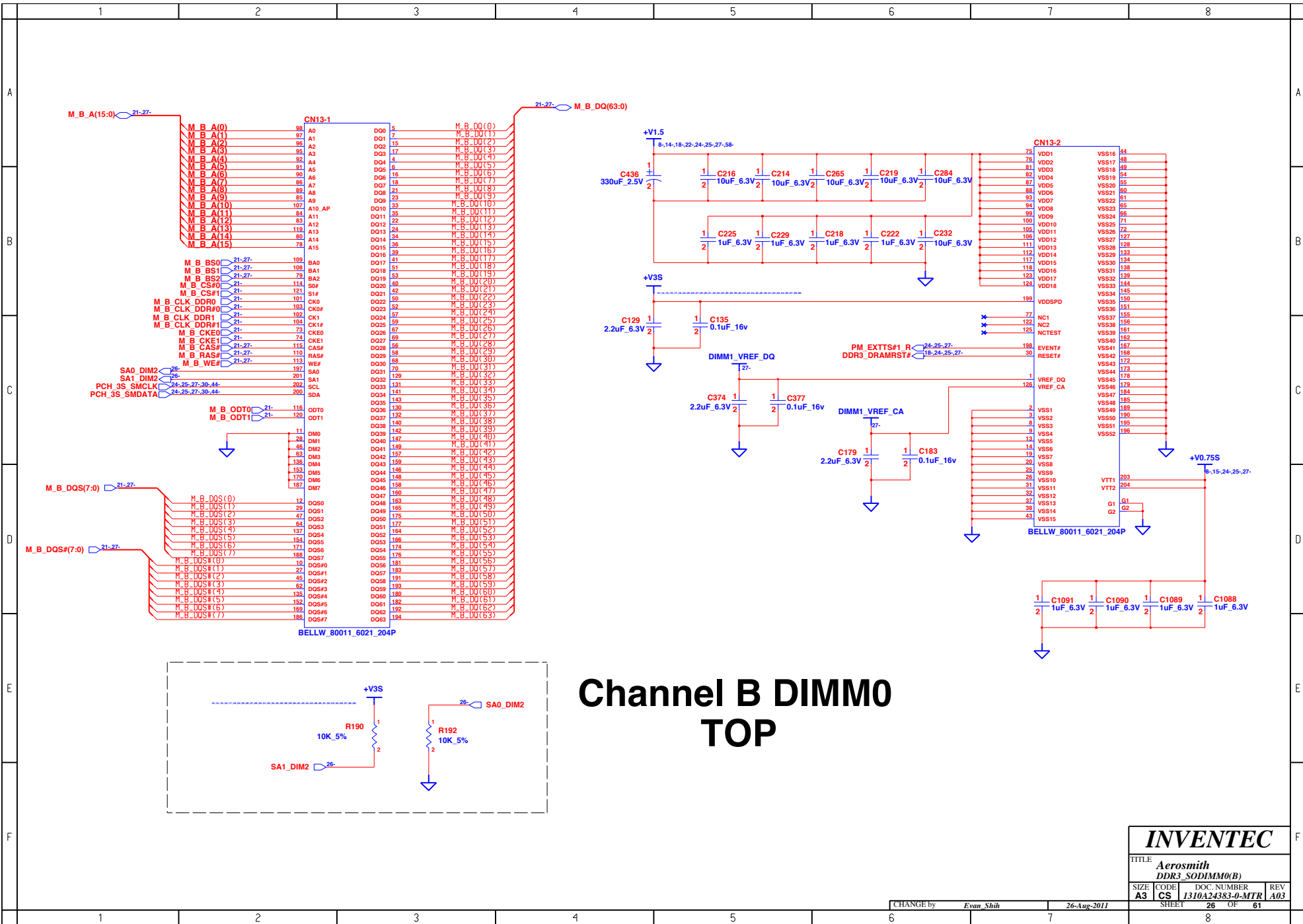

Channel B DIMM0 TOP

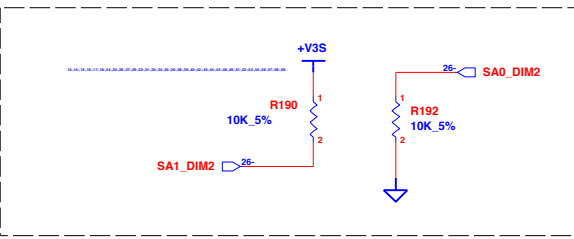

INVENTEC			
TITLE Aerosmith DDR3_SODIMM0(B)			
SIZE A3	CODE CS	DOC. NUMBER 1310A24383-0-MTR	REV A03
CHANGE by Evan Shih		26-Aug-2011	
SHEET 26		OF 61	

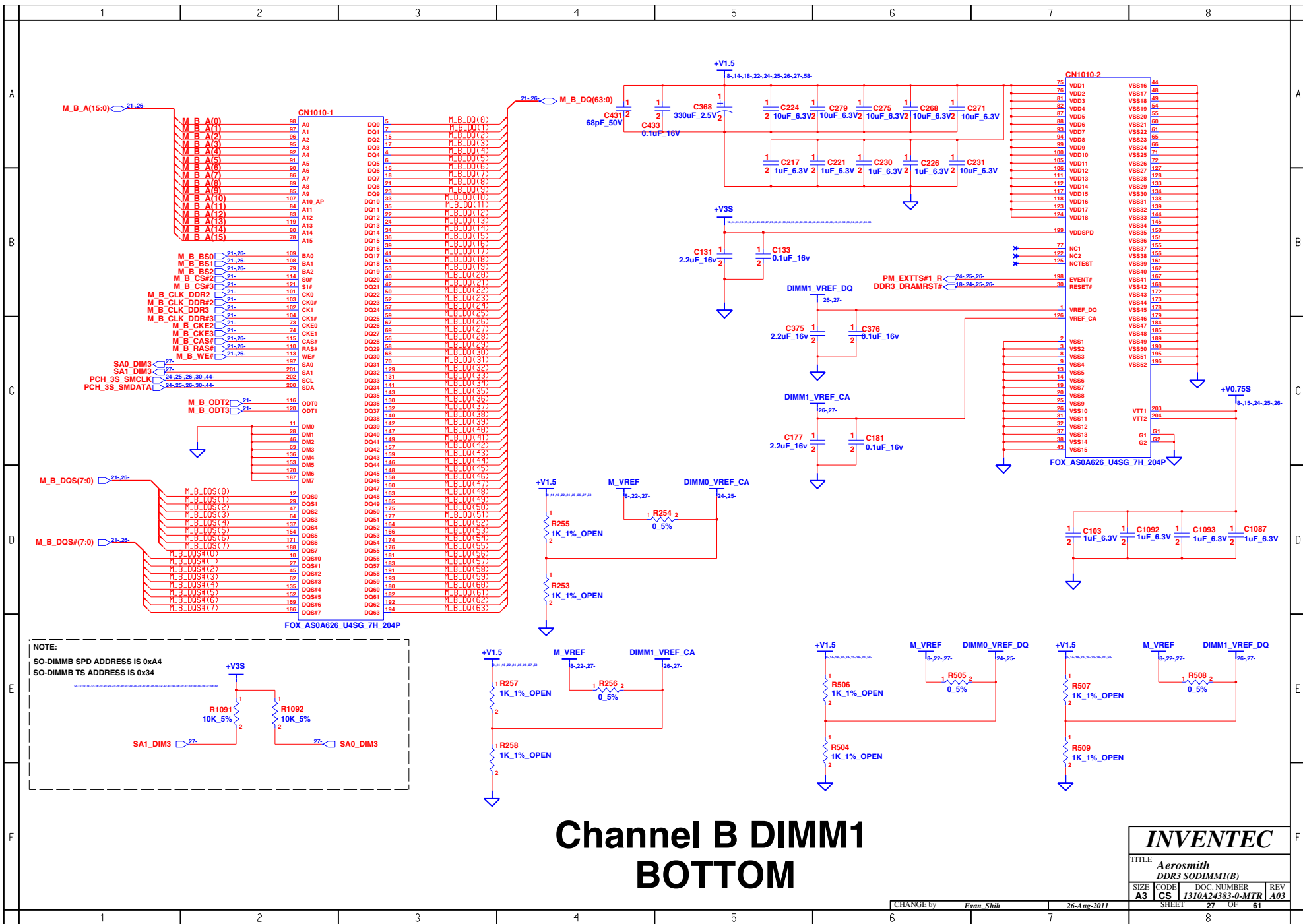

Channel B DIMM1 BOTTOM

INVENTEC			
TITLE Aerosmith DDR3 SODIMM1(B)			
SIZE A3	CODE CS	DOC. NUMBER 1310A24383-0-MTR	REV A03
CHANGE by Evan Shih		26-Aug-2011	
SHEET 27		OF 61	

BLANK

INVENTEC

TITLE			
<i>Aerosmith DDR3_VREF</i>			
SIZE	CODE	DOC. NUMBER	REV
A3	CS	<i>1310A24383-0-MTR</i>	A03
SHEET		28	OF 61

CHANGE by *Evan Shih* 26-Aug-2011

SHEET 28 OF 61

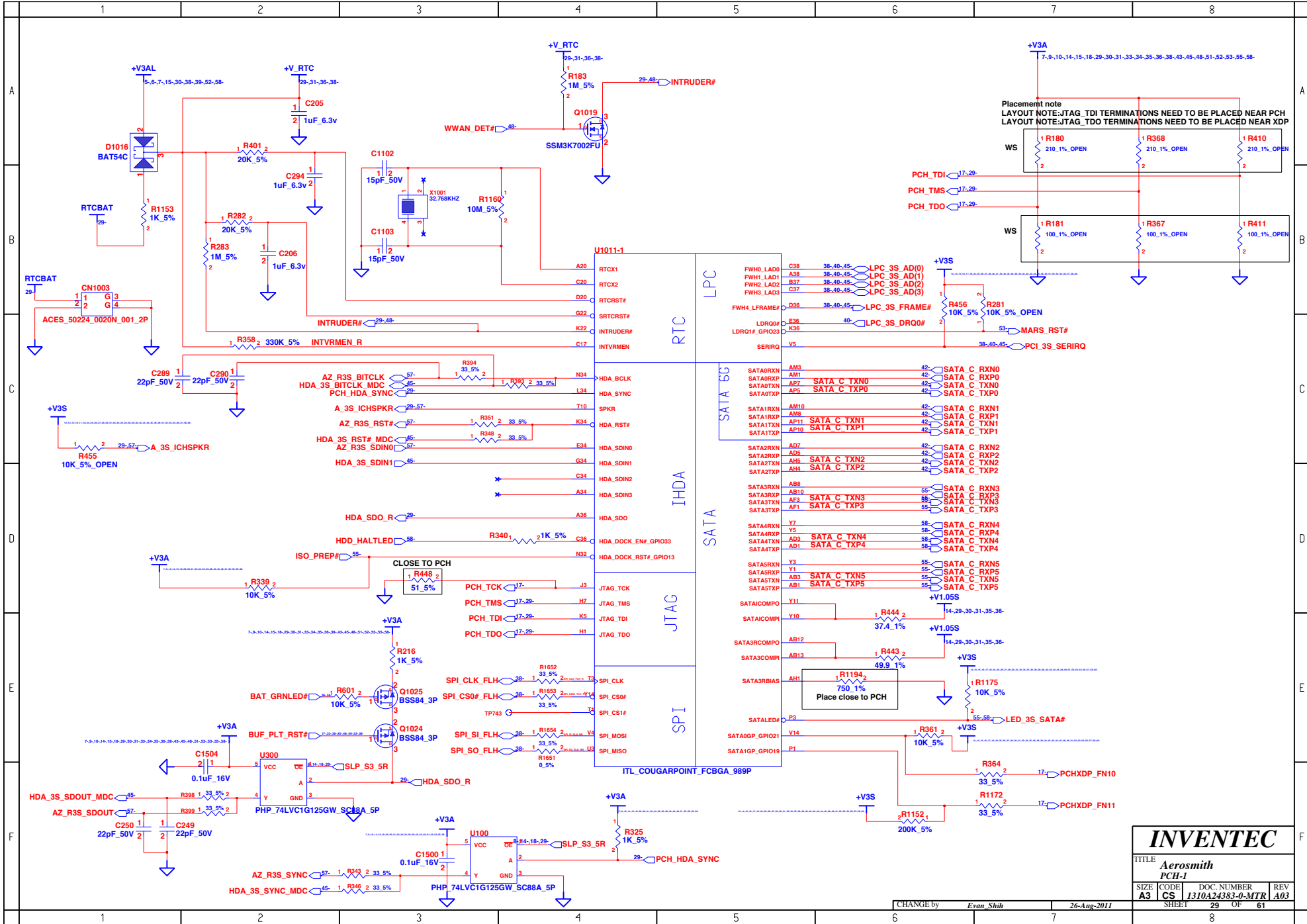

INVENTEC			
TITLE Aerosmith PCH-1			
SIZE A3	CODE CS	DOC. NUMBER 1310A24383-0-MTR	REV A03
SHEET 29		OF 61	

CHANGE by *Evon Shih* 26-Aug-2011

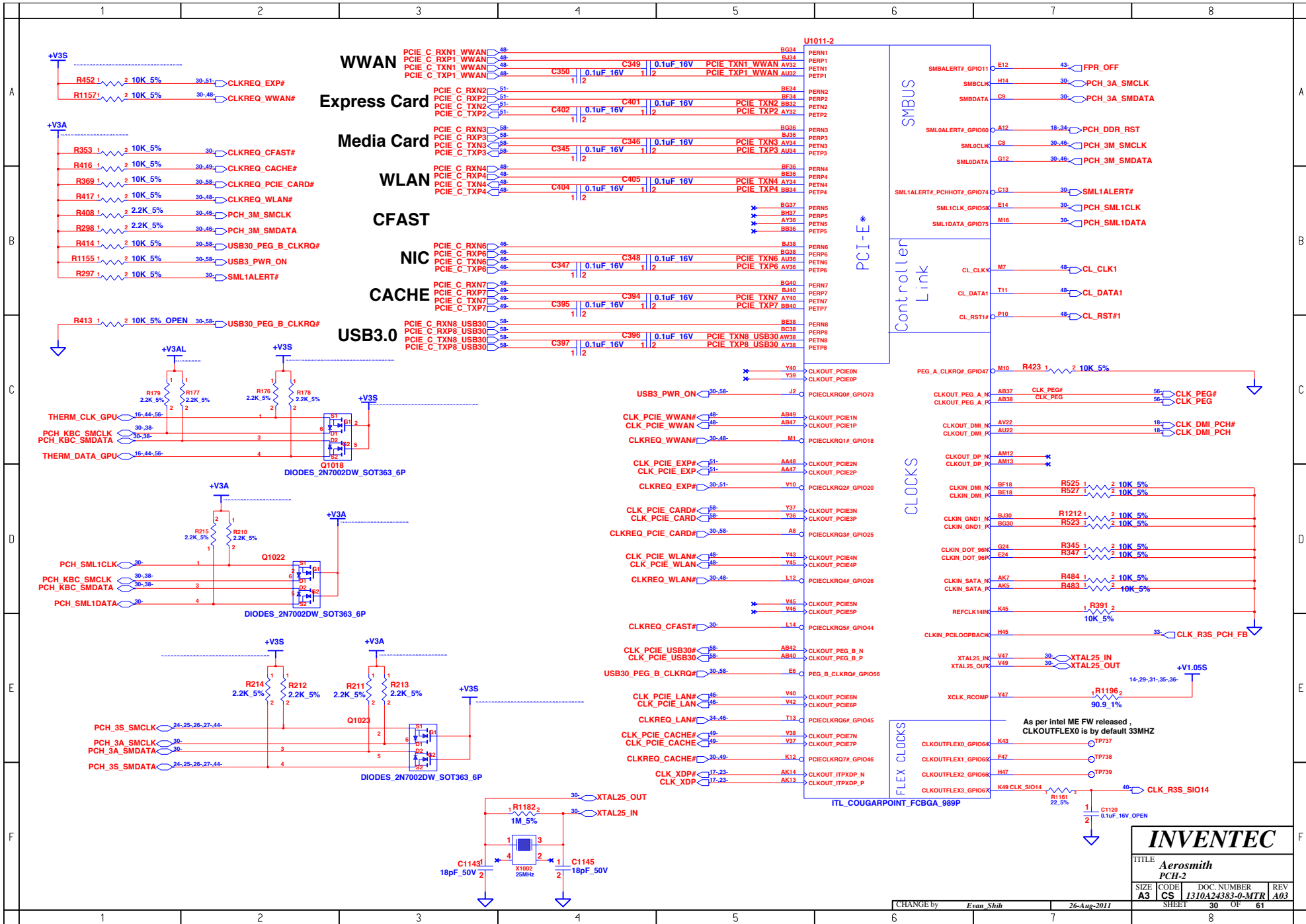

INVENTEC

TITLE
**Aerosmith
PCH-2**

SIZE A3	CODE CS	DOC. NUMBER 1310A24383-0-MTR	REV A03
SHEET 30		OF 61	

CHANGE by *Evan Shih* 26-Aug-2011

Note: 1.SLP_SUS and SUSACK# are NC if DSW is not supported
 2.DPWROK should connect to RSMRST# if DSW not supported
 3.PCH_DPWROK pull up to +V3S enables DSW support. No install R5261 to disable DSW

A

B

C

D

E

F

A

B

C

D

E

F

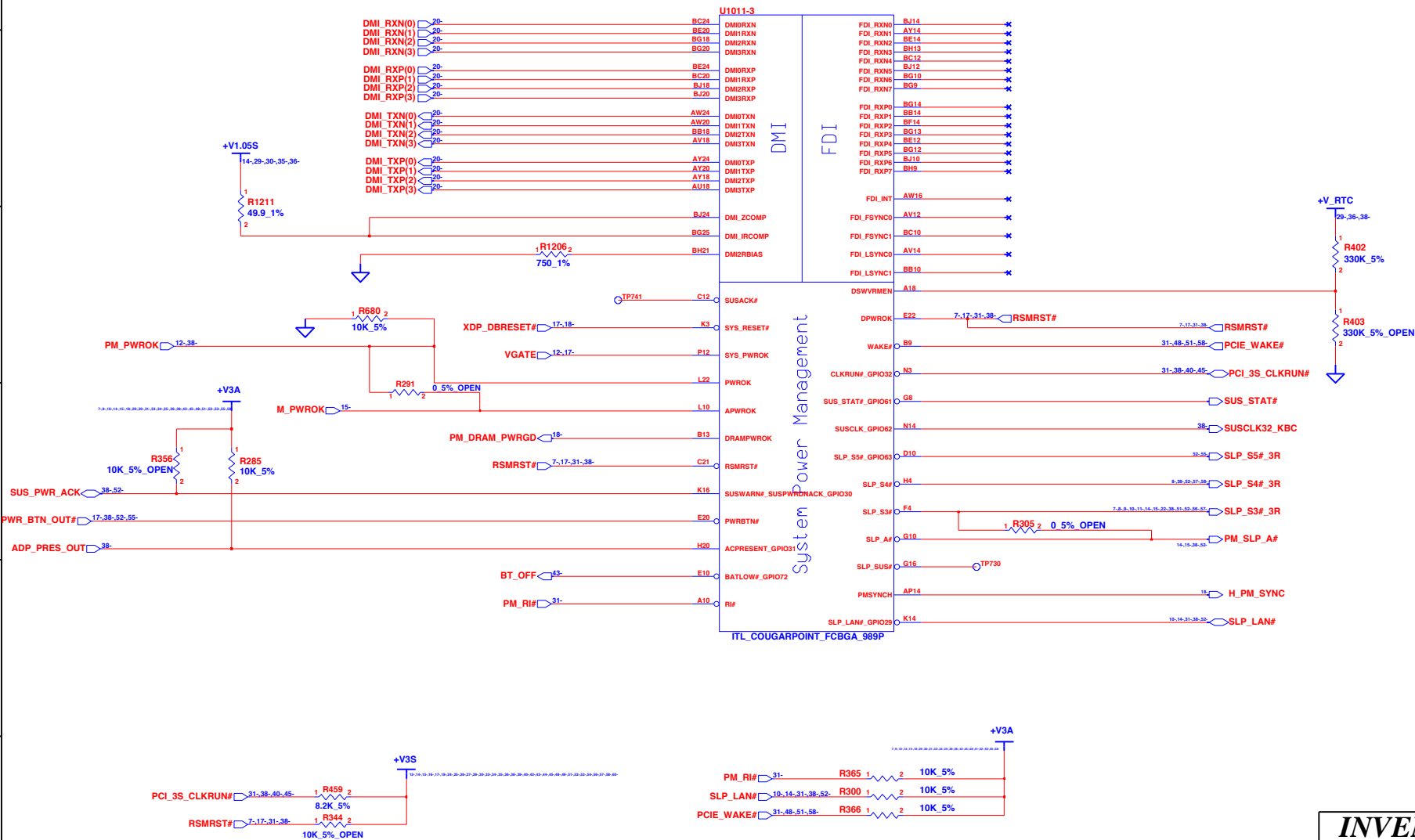

INVENTEC			
TITLE Aerosmith PCH-3			
SIZE A3	CODE CS	DOC. NUMBER I310A24383-0-MTR	REV A03
CHANGE by <i>Evan Shih</i>		26-Aug-2011	
SHEET 31		OF 61	

1

2

3

4

5

6

7

8

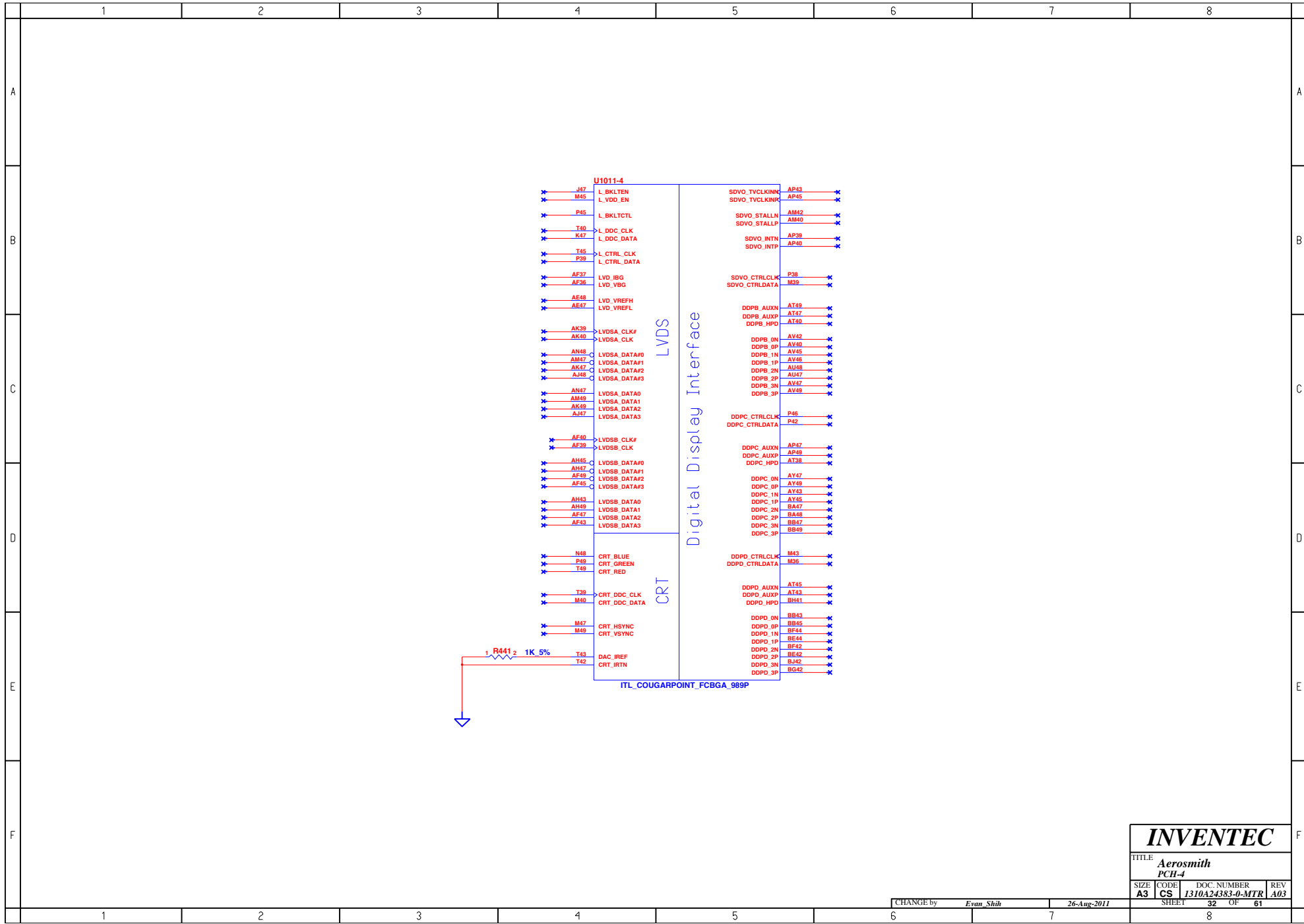

INVENTEC			
TITLE <i>Aerosmith</i> <i>PCH-4</i>			
SIZE A3	CODE CS	DOC. NUMBER <i>1310A24383-0-MTR</i>	REV A03
CHANGE by <i>Evan Shih</i>		26-Aug-2011	
SHEET 32		OF 61	

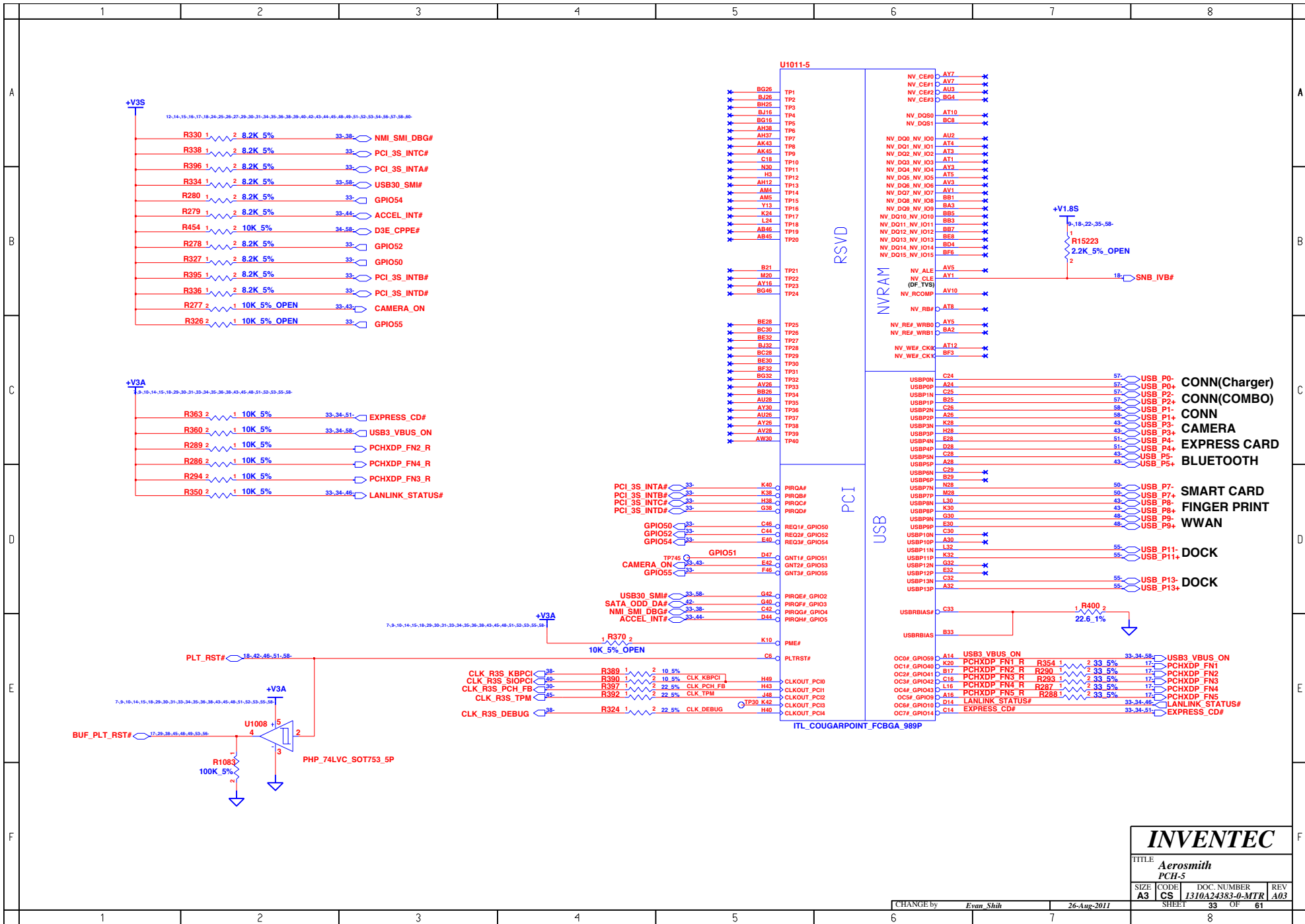

INVENTEC			
TITLE <i>Aerosmith</i> PCH-5			
SIZE A3	CODE CS	DOC. NUMBER <i>1310A24383-0-MTR</i>	REV A03
CHANGE by <i>Evan Shih</i>		26-Aug-2011	
SHEET 33		OF 61	

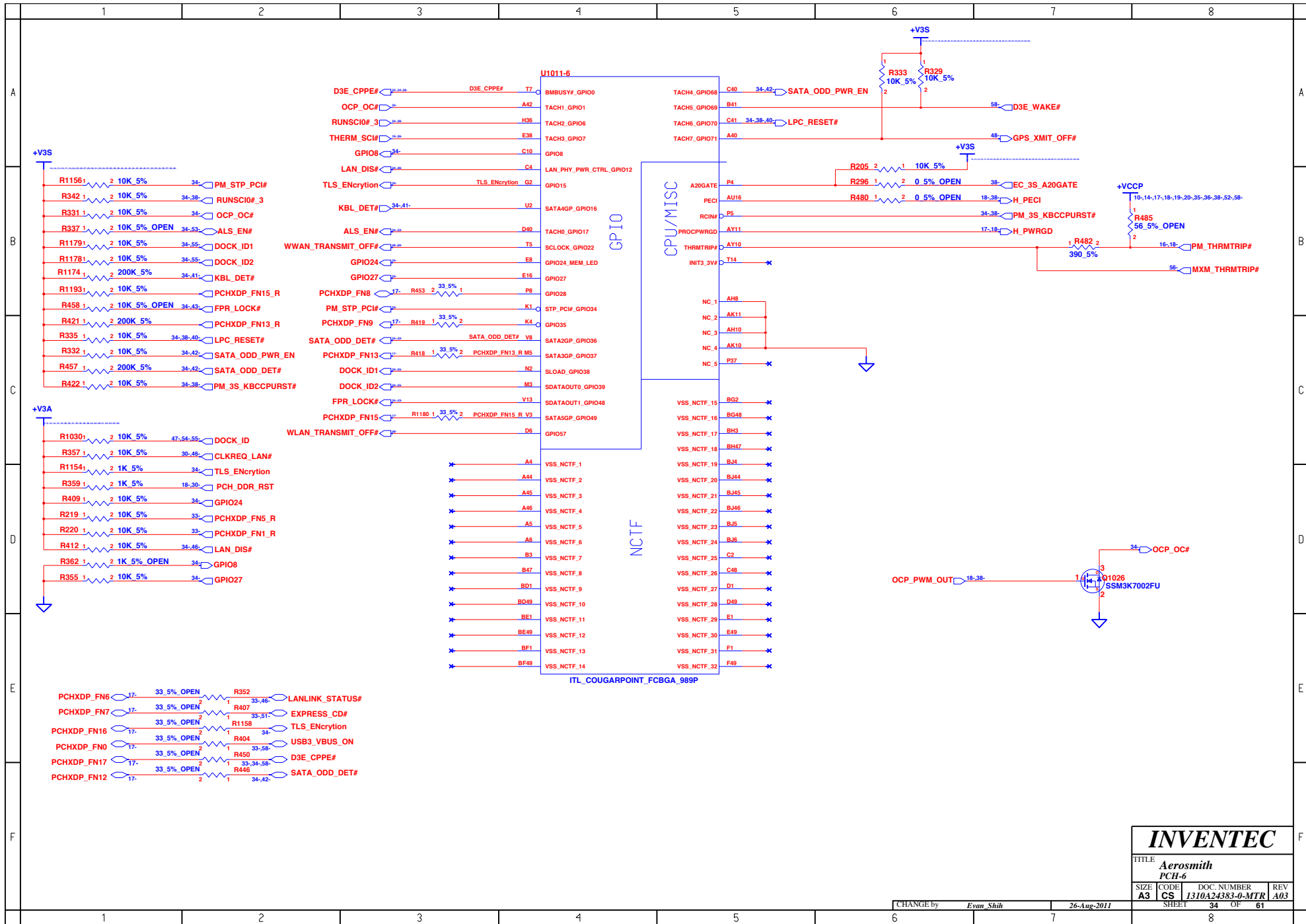

INVENTEC

TITLE			
Aerosmith			
PCH-6			
SIZE	CODE	DOC. NUMBER	REV
A3	CS	1310A24383-0-MTR	A03
SHEET		OF	
34		61	

CHANGE by *Evon Shih* 26-Aug-2011

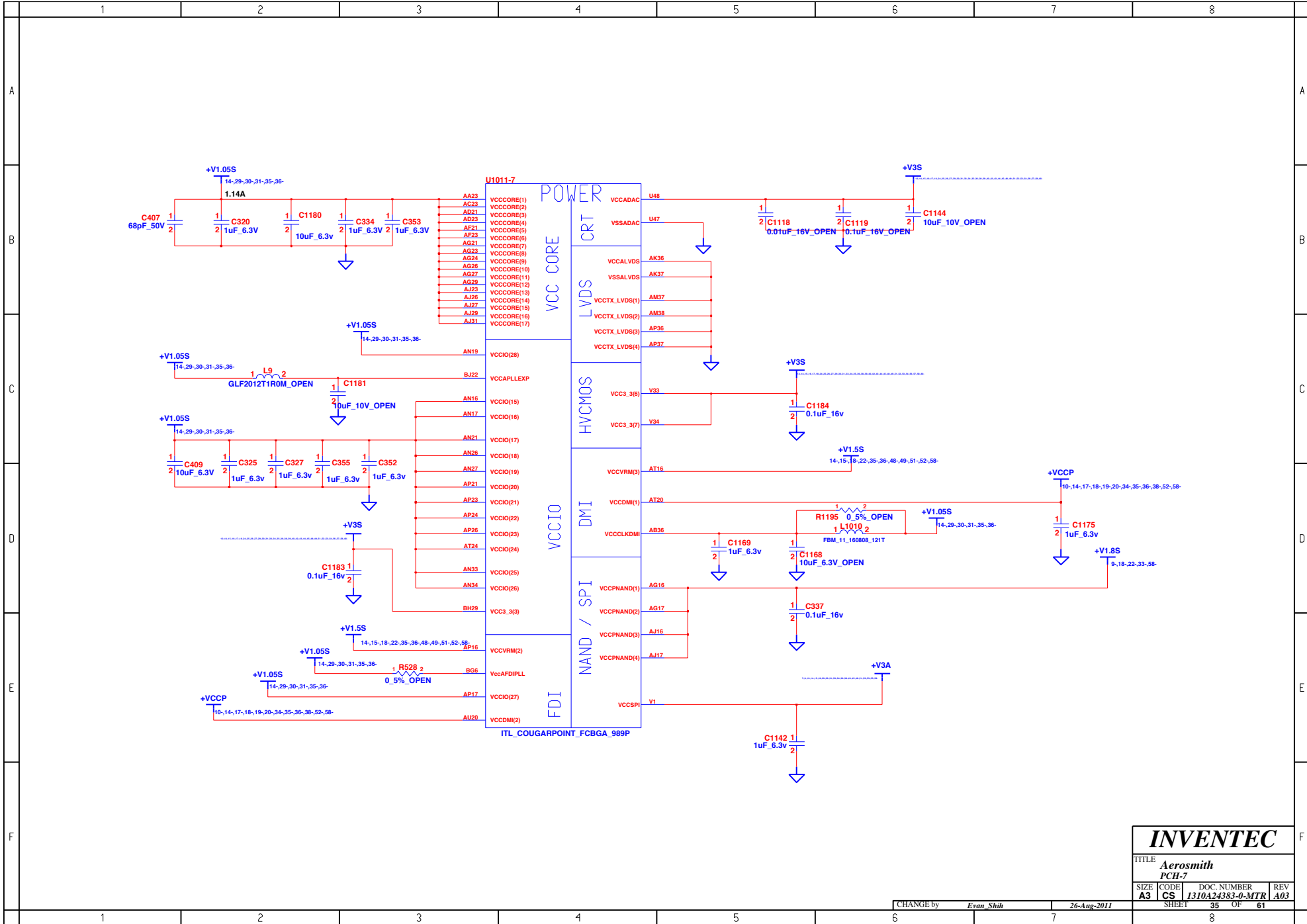

INVENTEC

TITLE			
Aerosmith			
PCH-7			
SIZE	CODE	DOC. NUMBER	REV
A3	CS	1310A24383-0-MTR	A03
SHEET		OF	
35		61	

CHANGE by *Evon Shih* 26-Aug-2011

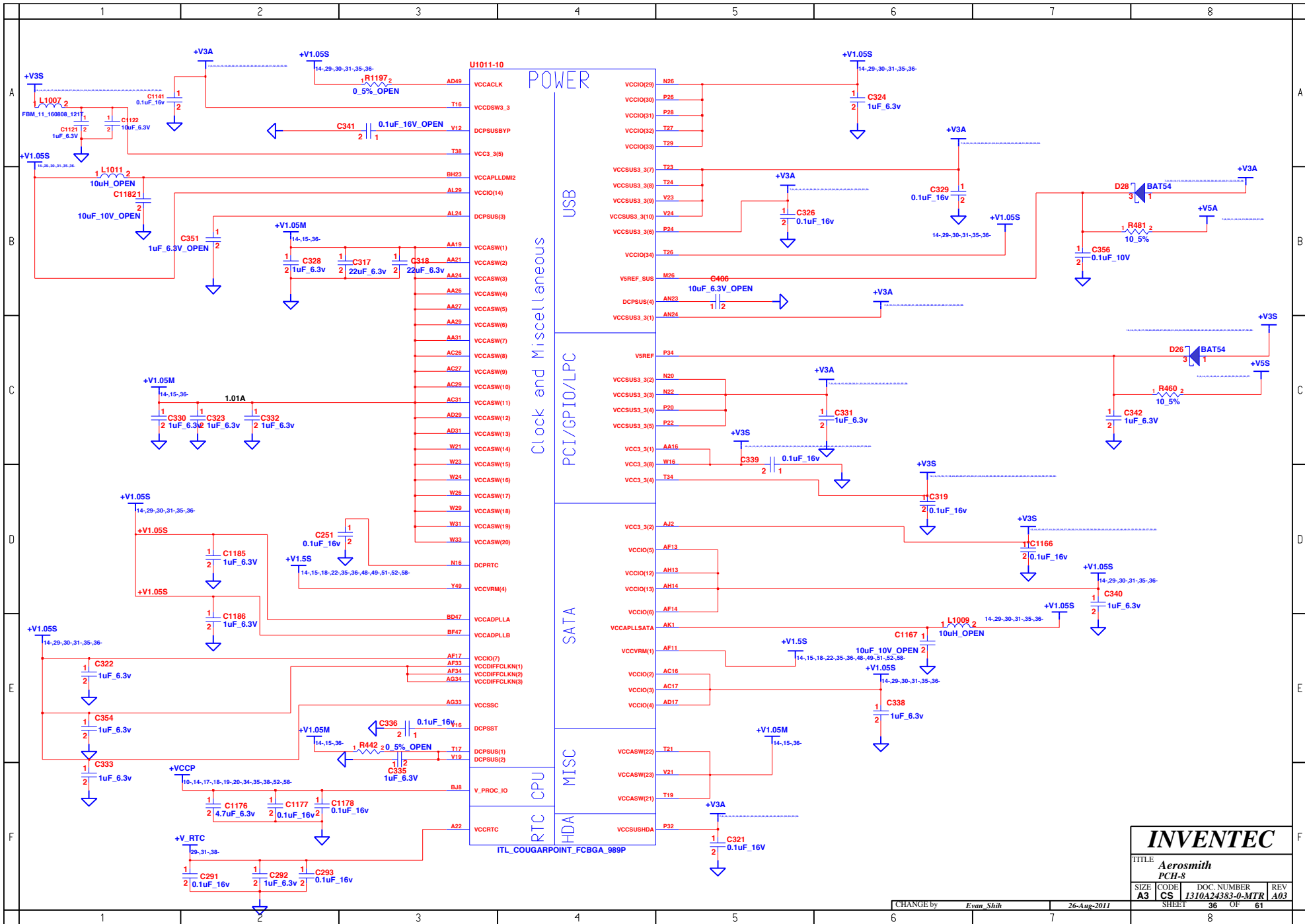

INVENTEC			
TITLE Aerosmith PCH-8			
SIZE A3	CODE CS	DOC. NUMBER 1310A24383-0-MTR	REV A03
CHANGE by Evan Shih		26-Aug-2011	
SHEET 36		OF 61	

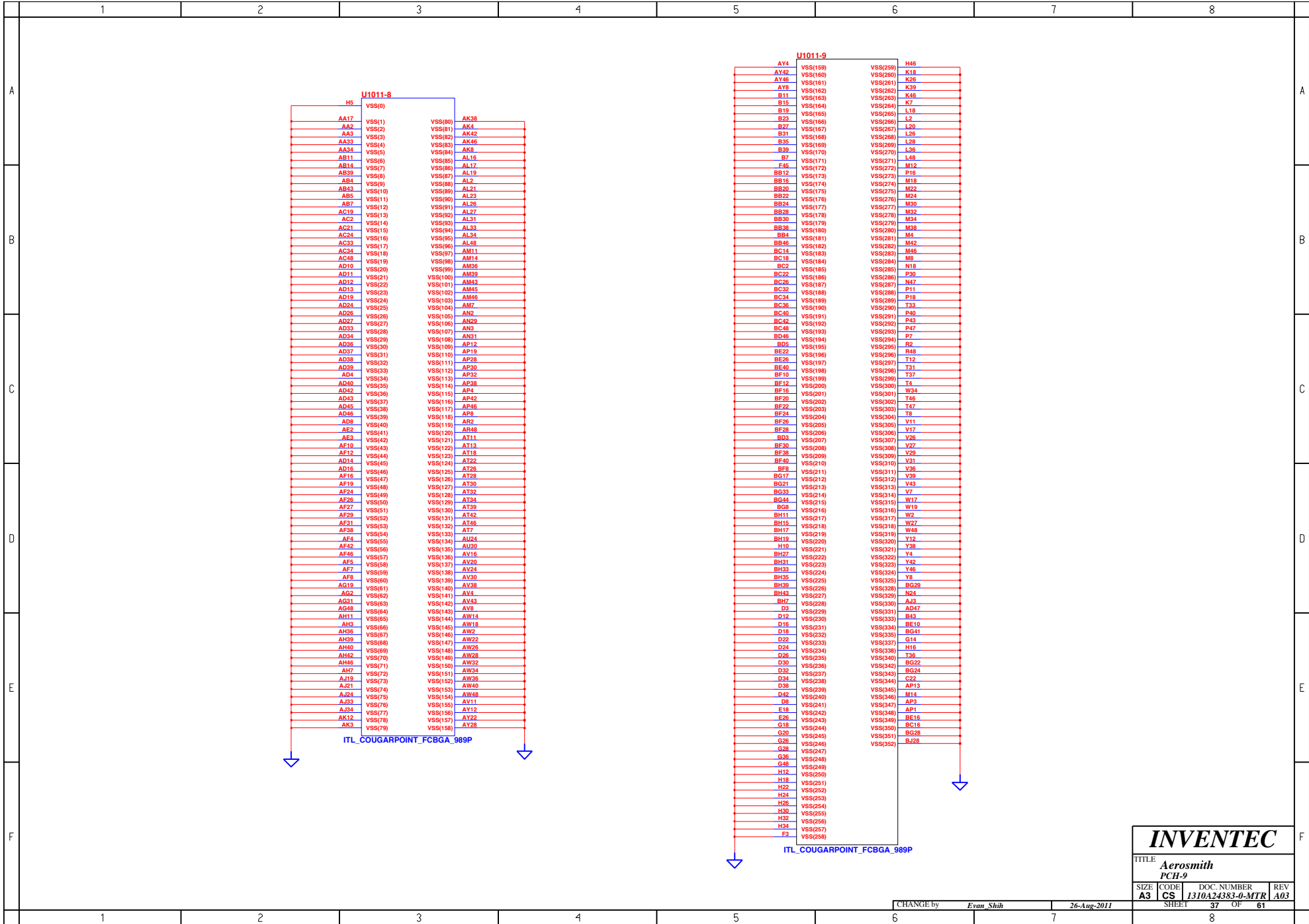

U1011-8

HS	VSS(0)
AA17	VSS(1)
AA2	VSS(2)
AA3	VSS(3)
AA33	VSS(4)
AA34	VSS(5)
AB11	VSS(6)
AB14	VSS(8)
AB39	VSS(9)
AB4	VSS(10)
AB5	VSS(11)
AB7	VSS(12)
AC19	VSS(13)
AC2	VSS(14)
AC21	VSS(15)
AC24	VSS(16)
AC33	VSS(17)
AC34	VSS(18)
AC48	VSS(19)
AD10	VSS(20)
AD11	VSS(21)
AD12	VSS(22)
AD13	VSS(23)
AD19	VSS(24)
AD24	VSS(25)
AD26	VSS(26)
AD27	VSS(27)
AD33	VSS(28)
AD34	VSS(29)
AD36	VSS(30)
AD37	VSS(31)
AD38	VSS(32)
AD39	VSS(33)
AD4	VSS(34)
AD40	VSS(35)
AD42	VSS(36)
AD43	VSS(37)
AD45	VSS(38)
AD48	VSS(39)
AD8	VSS(40)
AE2	VSS(41)
AE3	VSS(42)
AF10	VSS(43)
AF12	VSS(44)
AD14	VSS(45)
AD16	VSS(46)
AF18	VSS(47)
AF24	VSS(48)
AF28	VSS(49)
AF27	VSS(50)
AF28	VSS(51)
AF29	VSS(52)
AF31	VSS(53)
AF38	VSS(54)
AF4	VSS(55)
AF42	VSS(56)
AF46	VSS(57)
AF5	VSS(58)
AF7	VSS(59)
AG1	VSS(60)
AG19	VSS(61)
AG2	VSS(62)
AG31	VSS(63)
AG48	VSS(64)
AH11	VSS(65)
AH3	VSS(66)
AH38	VSS(67)
AH39	VSS(68)
AH40	VSS(69)
AH42	VSS(70)
AH46	VSS(71)
AH7	VSS(72)
AJ19	VSS(73)
AJ21	VSS(74)
AJ24	VSS(75)
AJ3	VSS(76)
AJ34	VSS(77)
AK12	VSS(78)
AK3	VSS(79)

U1011-9

AY4	VSS(159)
AY42	VSS(160)
AY46	VSS(161)
AY8	VSS(162)
B11	VSS(163)
B18	VSS(164)
B19	VSS(165)
B23	VSS(166)
B41	VSS(167)
B31	VSS(168)
B35	VSS(169)
B39	VSS(170)
B7	VSS(171)
F45	VSS(172)
BB12	VSS(173)
BB16	VSS(174)
BB20	VSS(175)
BB22	VSS(176)
BB24	VSS(177)
BB28	VSS(178)
BB38	VSS(179)
BB38	VSS(180)
BB4	VSS(181)
BB46	VSS(182)
BC14	VSS(183)
BC18	VSS(184)
BC2	VSS(185)
BC22	VSS(186)
BC26	VSS(187)
BC32	VSS(188)
BC34	VSS(189)
BC36	VSS(190)
BC40	VSS(191)
BC42	VSS(192)
BC48	VSS(193)
BD6	VSS(194)
BD5	VSS(195)
BE22	VSS(196)
BE26	VSS(197)
BE40	VSS(198)
BF10	VSS(199)
BF12	VSS(200)
BF16	VSS(201)
BF20	VSS(202)
BF22	VSS(203)
BF24	VSS(204)
BF26	VSS(205)
BF28	VSS(206)
BD3	VSS(207)
BF30	VSS(208)
BF38	VSS(209)
BF40	VSS(210)
BF8	VSS(211)
BG17	VSS(212)
BG21	VSS(213)
BG33	VSS(214)
BG44	VSS(215)
GG8	VSS(216)
BH11	VSS(217)
BH15	VSS(218)
BH17	VSS(219)
BH19	VSS(220)
HH0	VSS(221)
BH27	VSS(222)
BH31	VSS(223)
BH33	VSS(224)
BH38	VSS(225)
BH39	VSS(226)
BH43	VSS(227)
BH7	VSS(228)
D3	VSS(229)
D12	VSS(230)
D18	VSS(231)
D18	VSS(232)
D22	VSS(233)
D24	VSS(234)
D26	VSS(235)
D30	VSS(236)
D32	VSS(237)
D34	VSS(238)
D38	VSS(239)
D42	VSS(240)
D8	VSS(241)
E18	VSS(242)
E26	VSS(243)
G18	VSS(244)
G20	VSS(245)
G26	VSS(246)
G28	VSS(247)
G36	VSS(248)
G48	VSS(249)
H12	VSS(250)
H18	VSS(251)
H22	VSS(252)
H24	VSS(253)
H26	VSS(254)
H30	VSS(255)
H32	VSS(256)
H34	VSS(257)
F3	VSS(258)

CHANGE by *Evan Shih* 26-Aug-2011

INVENTEC

TITLE			
Aerosmith PCH-9			
SIZE	CODE	DOC. NUMBER	REV
A3	CS	1310A24383-0-MTR	A03
SHEET		37	OF 61

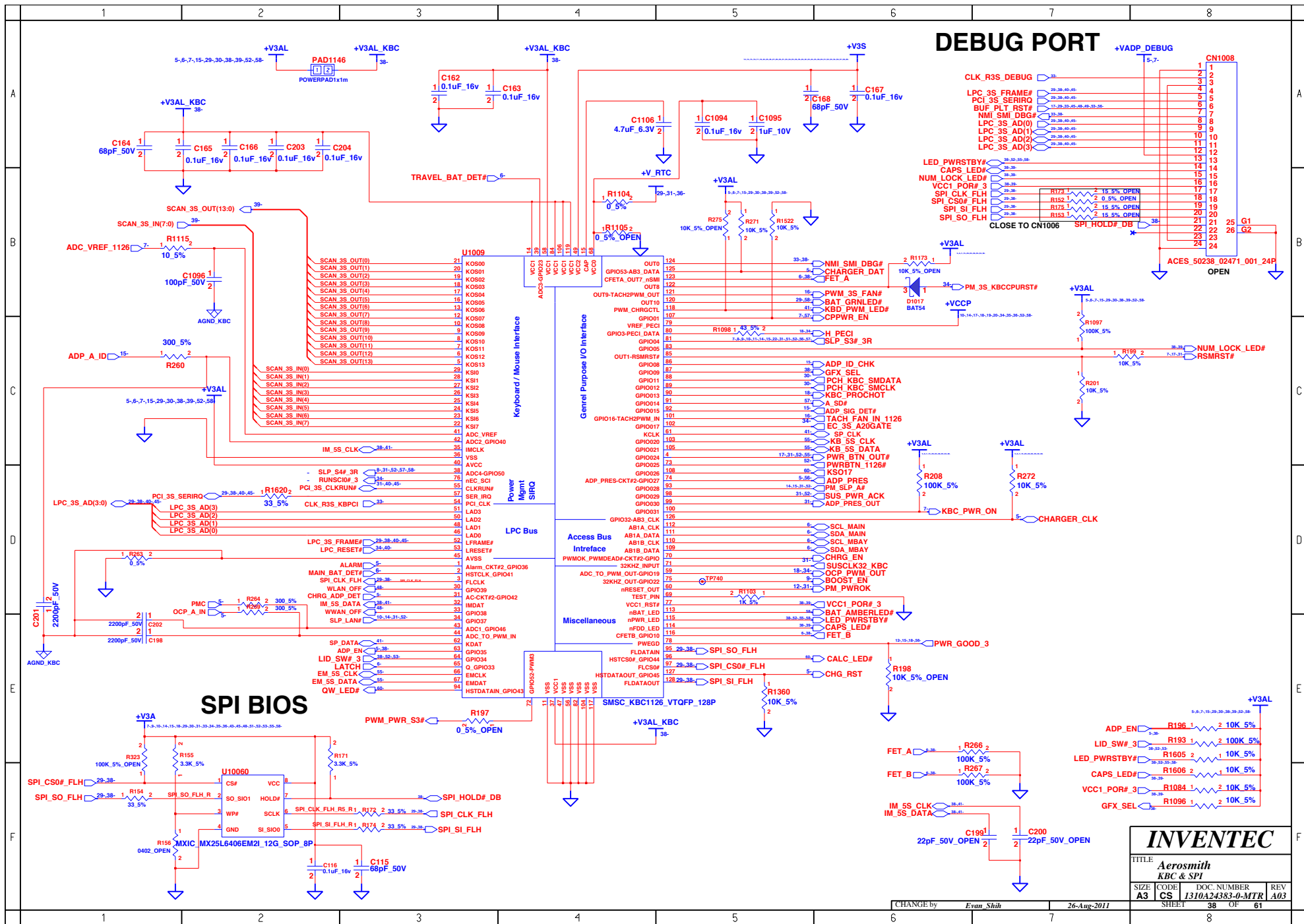

INVENTEC			
TITLE	Aerosmith KBC & SPI		
SIZE	CODE	DOC. NUMBER	REV
A3	CS	1310A24383-0-MTR	A03
SHEET	38	OF	61

CHANGE by *Evan Shih* 26-Aug-2011

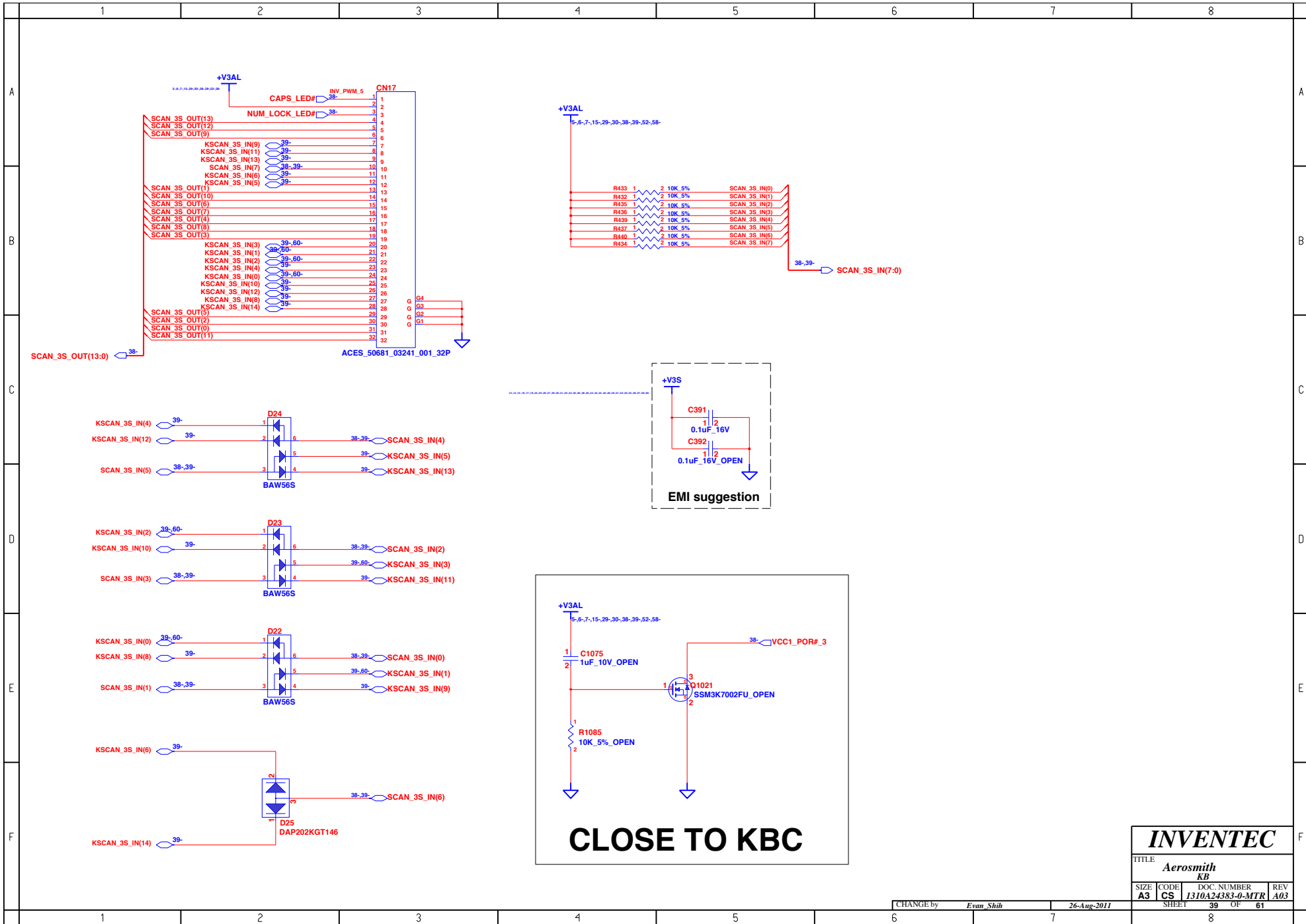

INVENTEC			
TITLE <i>Aerosmith</i> <i>KB</i>			
SIZE A3	CODE CS	DOC. NUMBER <i>1310A24383-0-MTR</i>	REV A03
SHEET		39	OF 61

CHANGE by *Evon Shih* 26-Aug-2011

CLOSE TO KBC

SUPER I/O

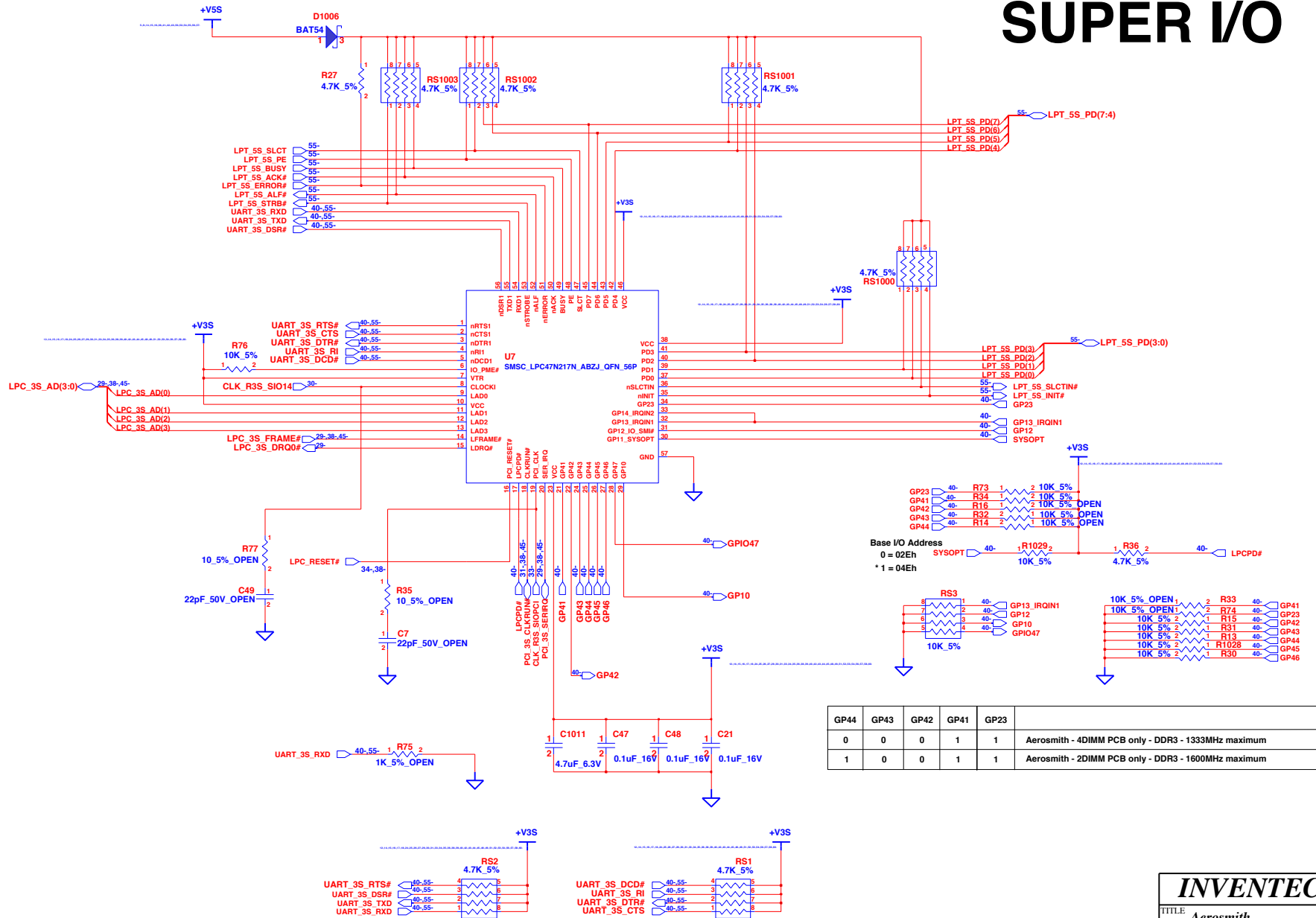

INVENTEC

TITLE Aerosmith SUPER I/O			
SIZE A3	CODE CS	DOC. NUMBER 1310A24383-0-MTR	REV A03
CHANGE by Evan Shih		26-Aug-2011	
SHEET 40		OF 61	

KEYBOARD_LIGHT_CNTR

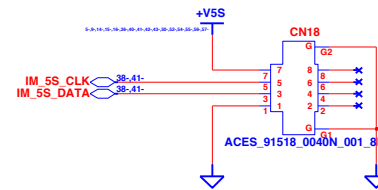
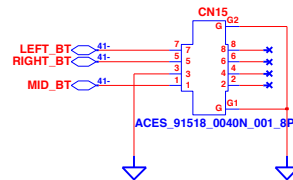
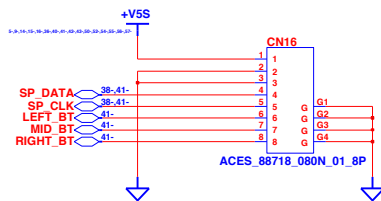
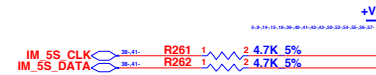
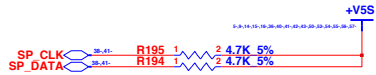
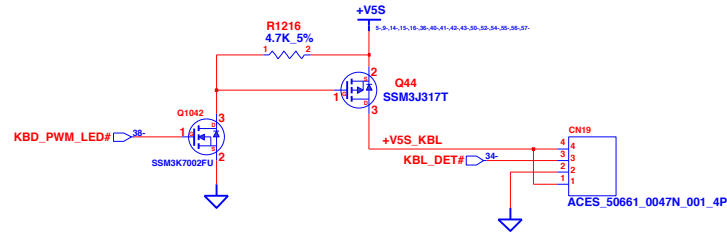

STICK POINT

TOUCH PAD

INVENTEC

TITLE			
Aerosmith KEYBOARD BACKLIGHT			
SIZE	CODE	DOC. NUMBER	REV
A3	CS	1310A24383-0-MTR	A03
CHANGE by		SHEET	OF
Evan Shih		41	61

26-Aug-2011

SATA HDD 0

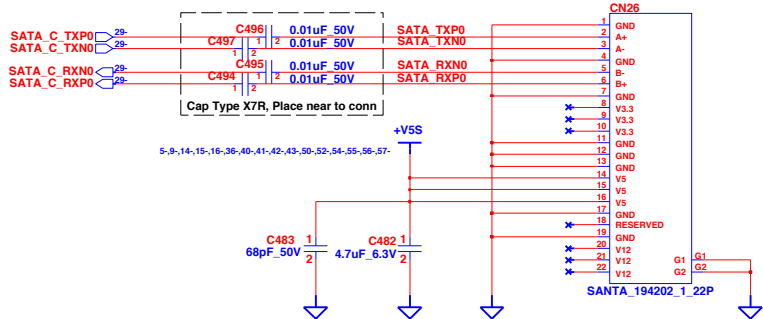

SATA HDD 1

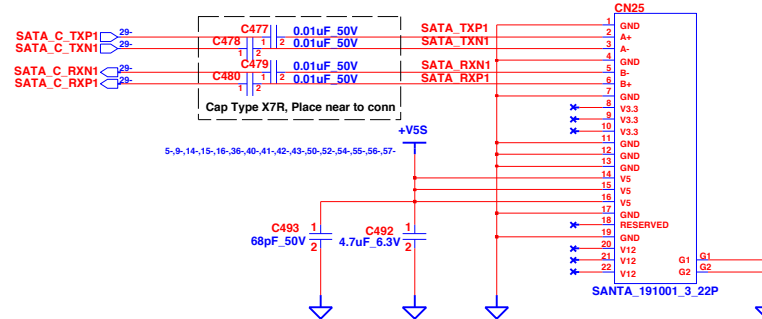

SATA ODD

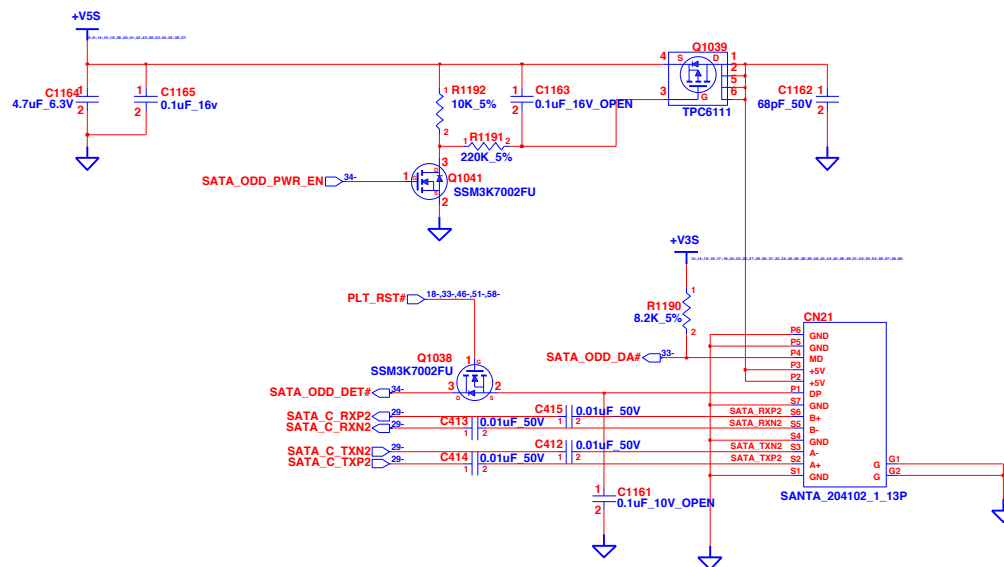

INVENTEC

TITLE			
Aerosmith SATA HDD & ODD			
SIZE	CODE	DOC. NUMBER	REV
A3	CS	1310A24383-0-MTR	A03
SHEET			OF
42			61

CHANGE by *Evan Shih* 26-Aug-2011

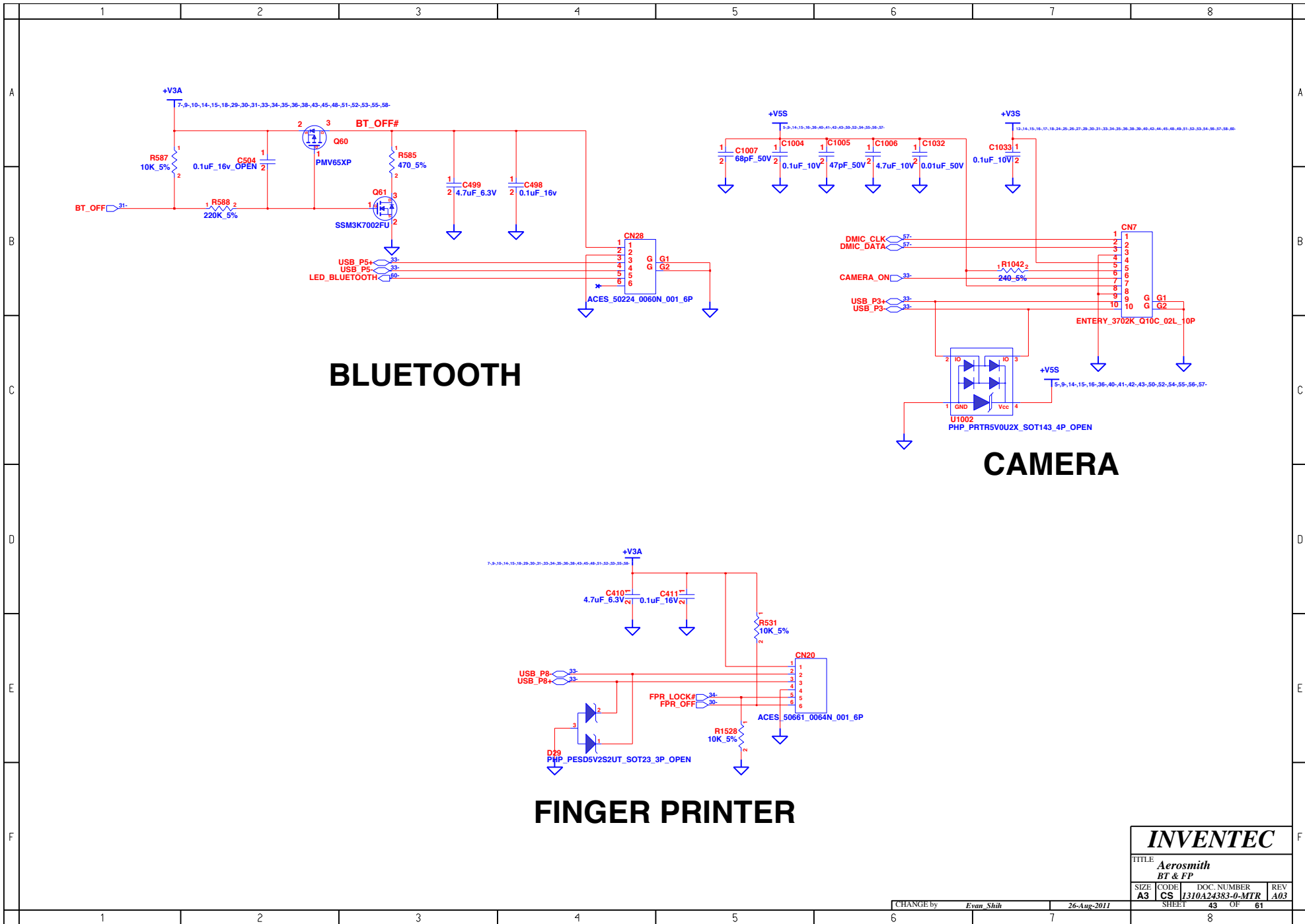

BLUETOOTH

CAMERA

FINGER PRINTER

INVENTEC			
TITLE Aerosmith BT & FP			
SIZE A3	CODE CS	DOC. NUMBER I310A24383-0-MTR	REV A03
CHANGE by <i>Evon Shih</i>		26-Aug-2011	
SHEET		43 OF 61	

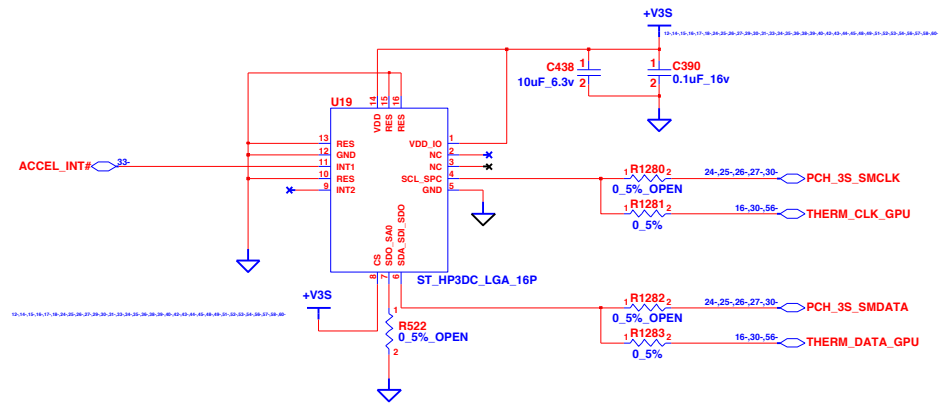

ACCELEROMETER

INVENTEC			
TITLE Aerosmith ACCELEROMETER			
SIZE A3	CODE CS	DOC. NUMBER 1310A24383-0-MTR	REV A03
CHANGE by <i>Evon Shih</i>		26-Aug-2011	
SHEET 44		OF 61	

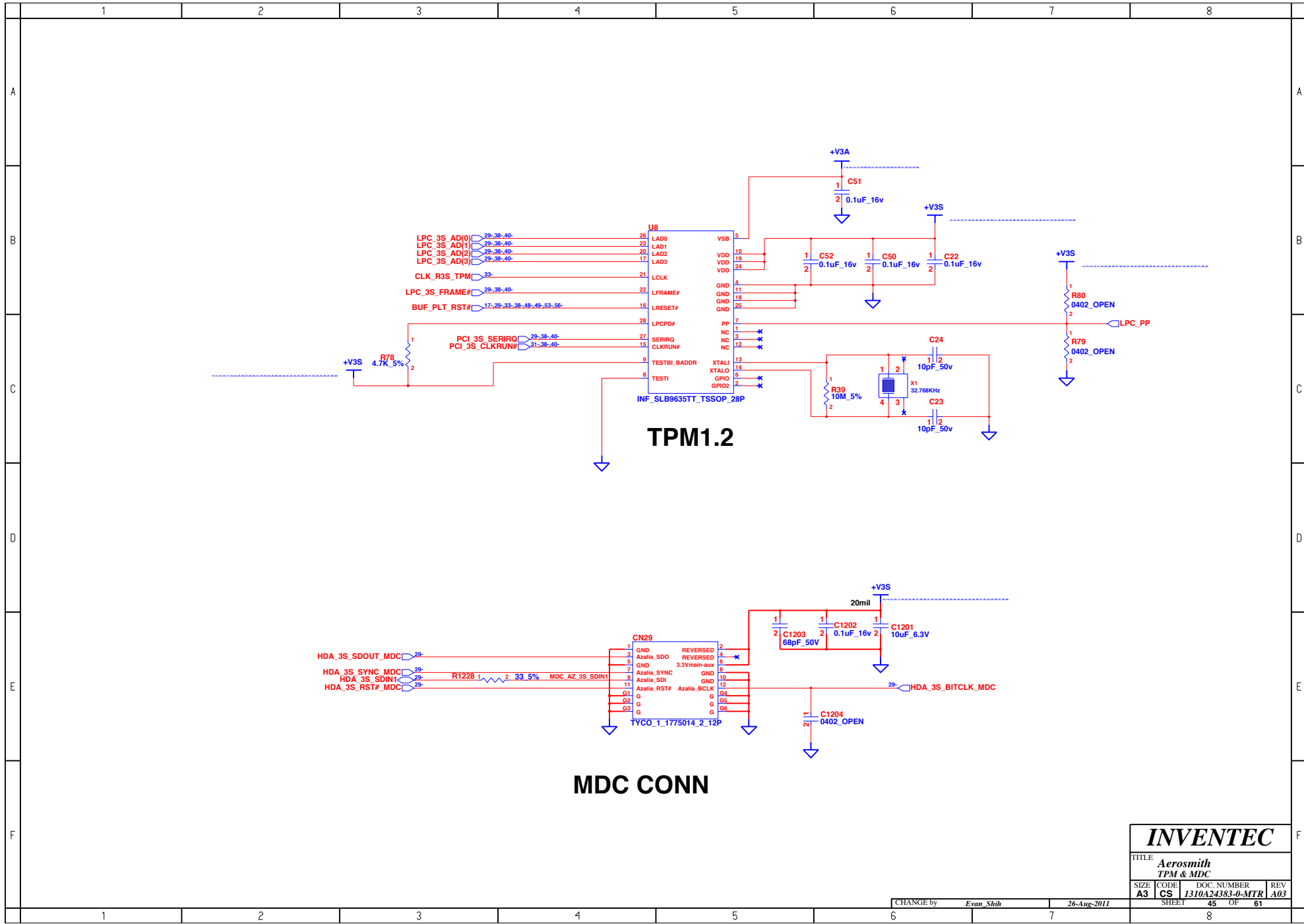

INVENTEC			
TITLE Aerosmith TPM & MDC			
SIZE A3	CODE CS	DOC. NUMBER 1310A24383-0-MTR	REV A03
CHANGE by <i>Evan Shih</i>		26-Aug-2011	
SHEET 45		OF 61	

LAN PHY

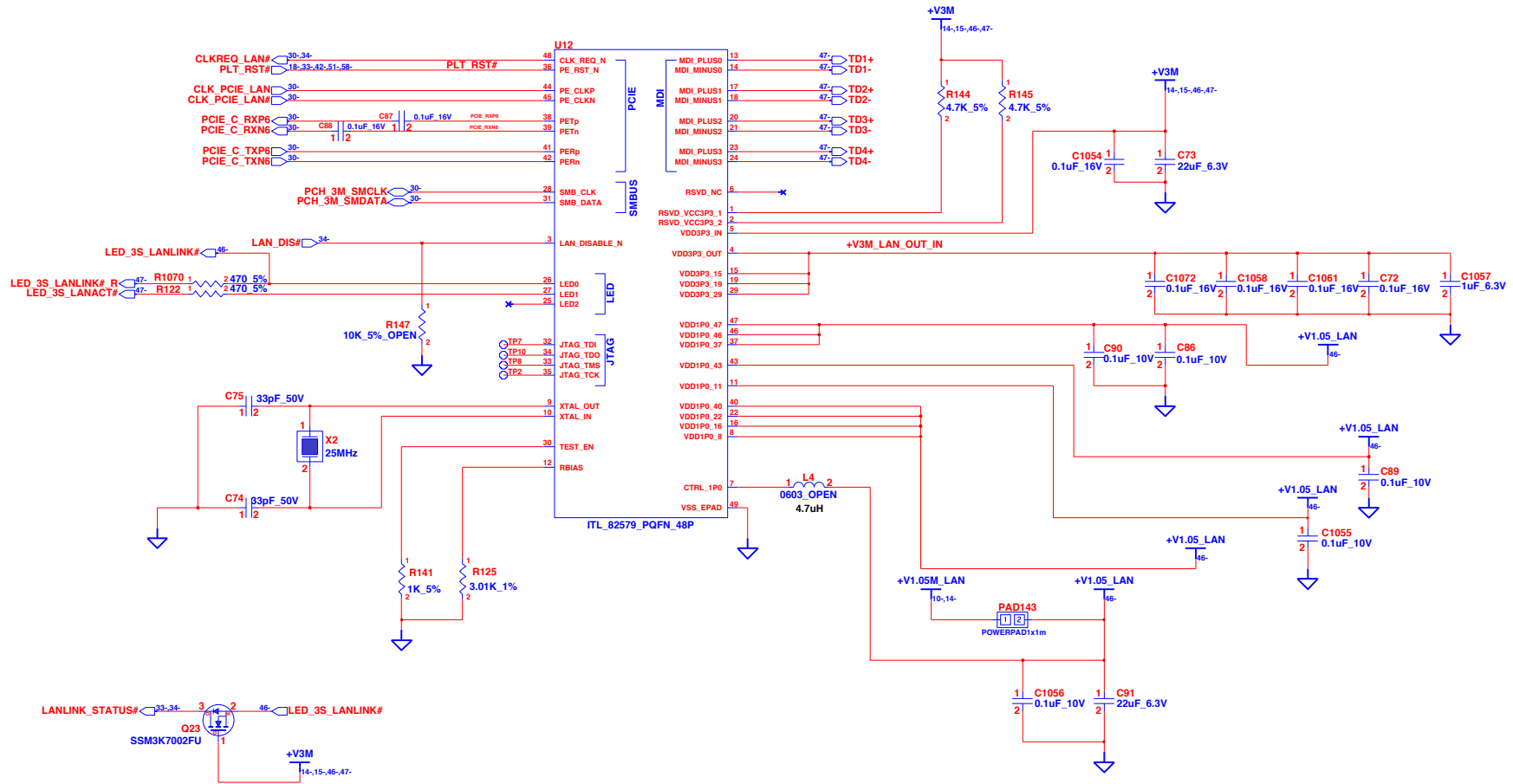

INVENTEC

TITLE			
Aerosmith LAN INTERFACE			
SIZE	CODE	DOC. NUMBER	REV
A3	CS	1310A24383-0-MTR	A03
SHEET			OF
46			61

CHANGE by *Evon Shih* 26-Aug-2011

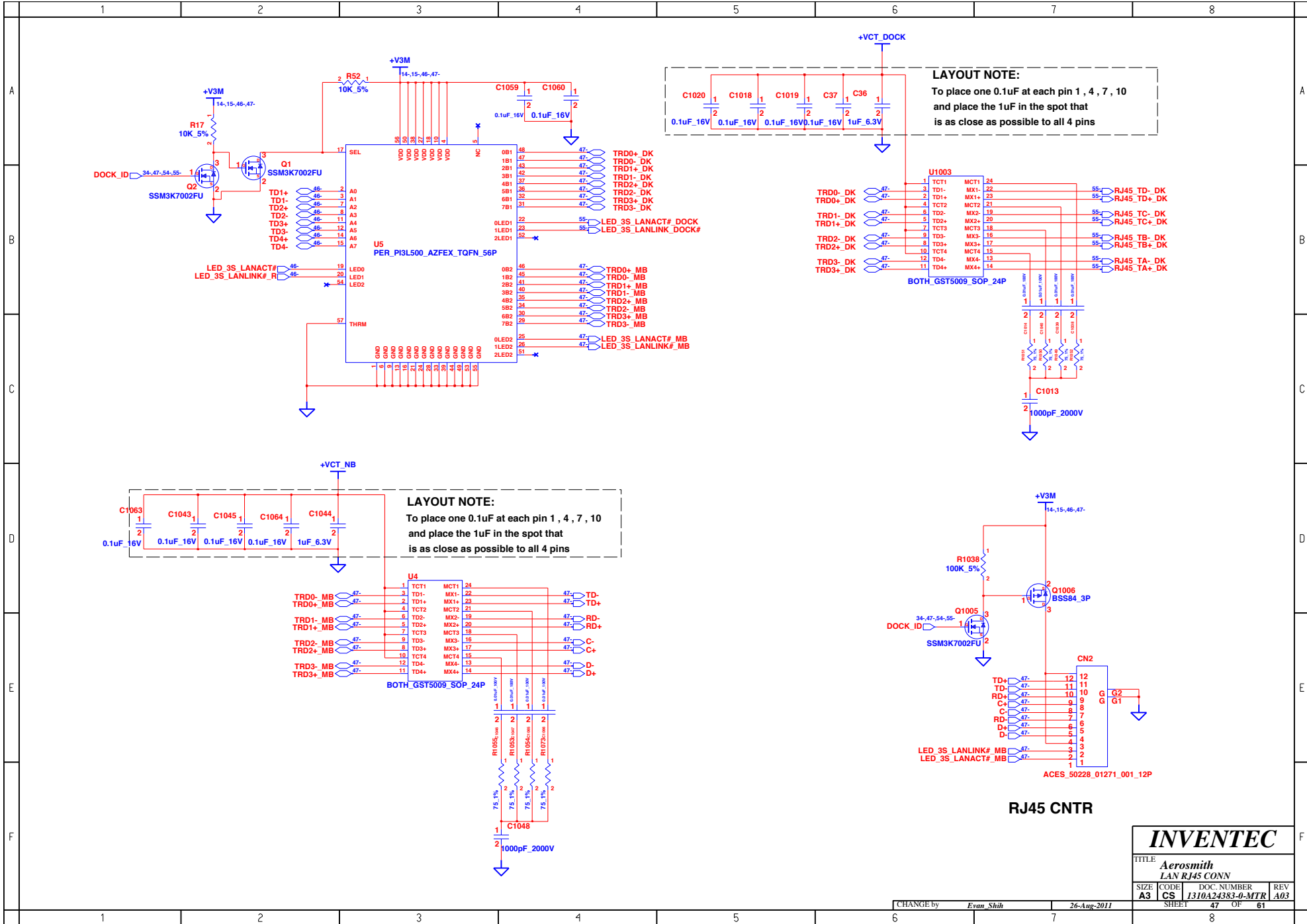

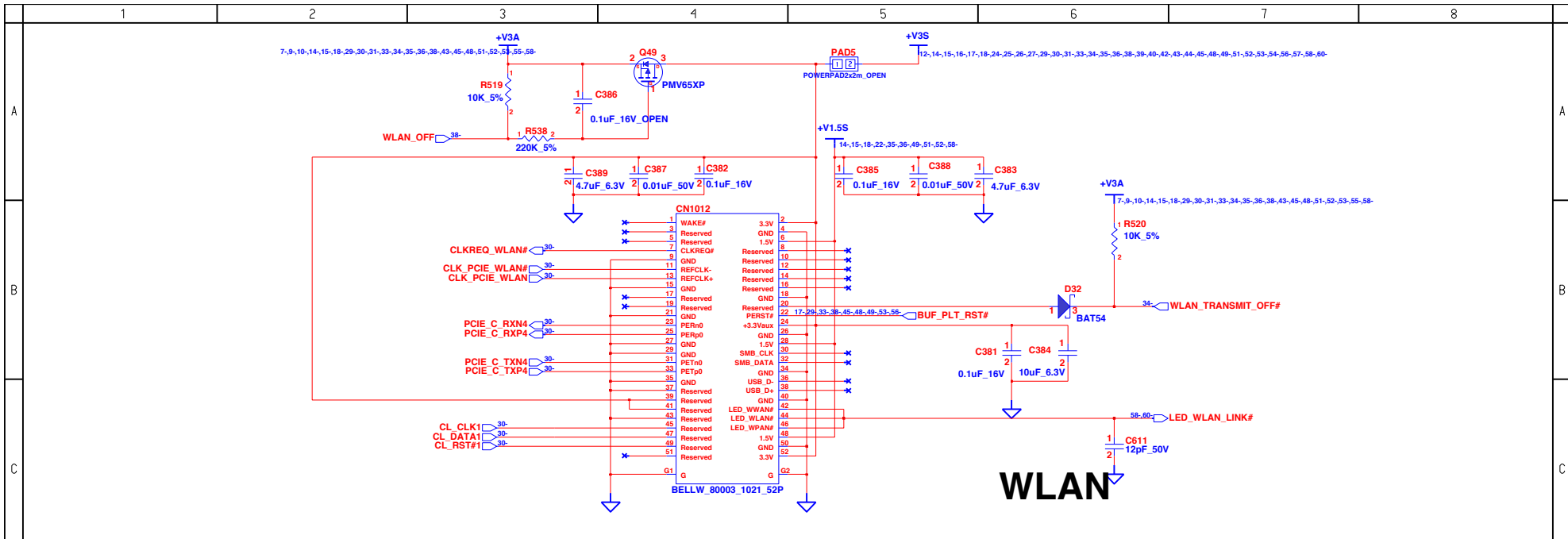

WLAN

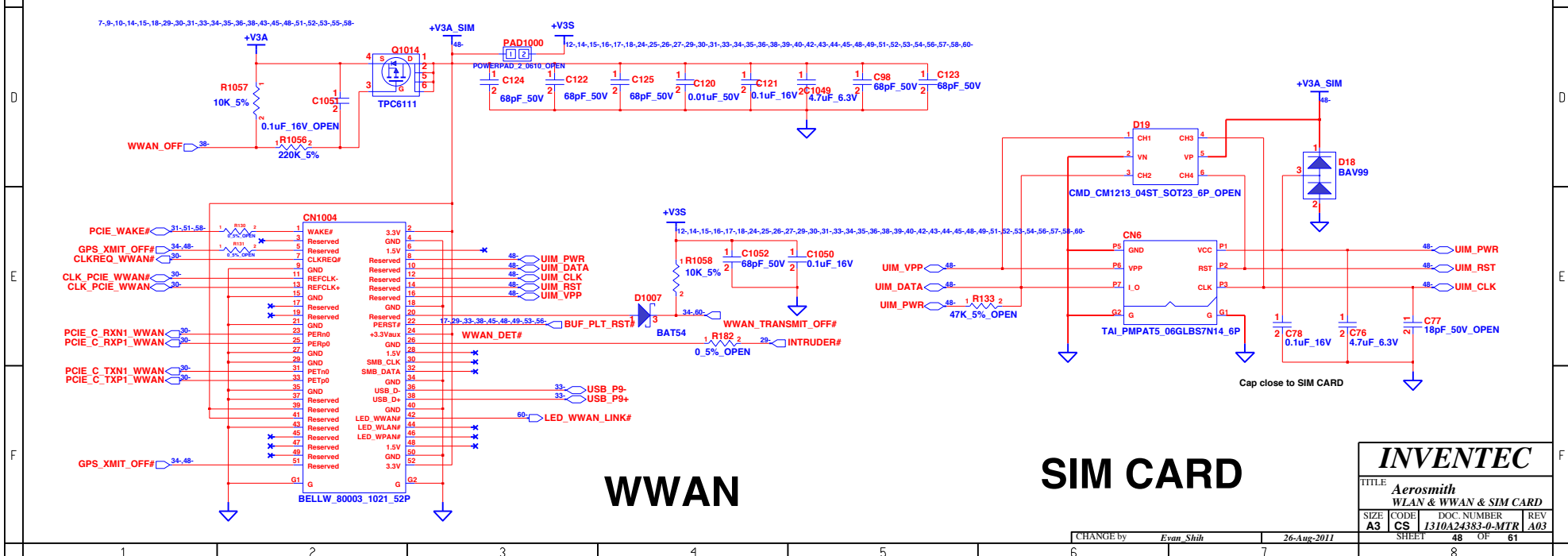

WWAN

SIM CARD

INVENTEC			
TITLE Aerosmith WLAN & WWAN & SIM CARD			
SIZE A3	CODE CS	DOC. NUMBER 1310A24383-0-MTR	REV A03
CHANGE by Evan Shih		26-Aug-2011	
SHEET 48		OF 61	

Flash Cache--Mini Card

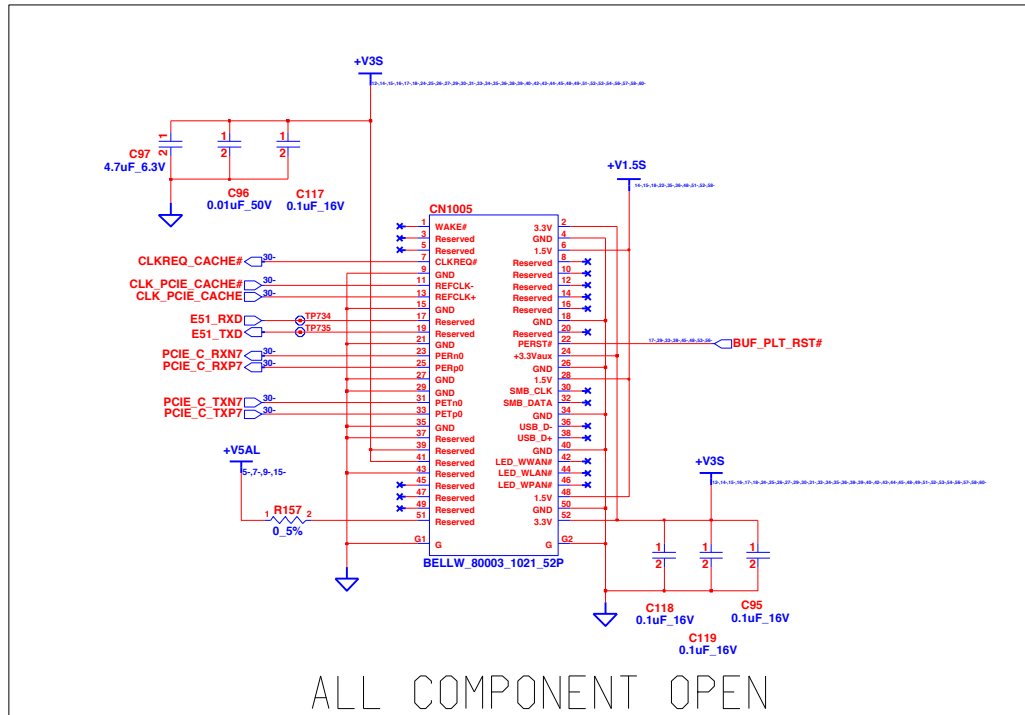

INVENTEC

TITLE			
Aerosmith FLASH CACHE			
SIZE	CODE	DOC. NUMBER	REV
A3	CS	1310A24383-0-MTR	A03
SHEET		49	OF 61

CHANGE by *Evan Shih* 26-Aug-2011

Smart Card Board

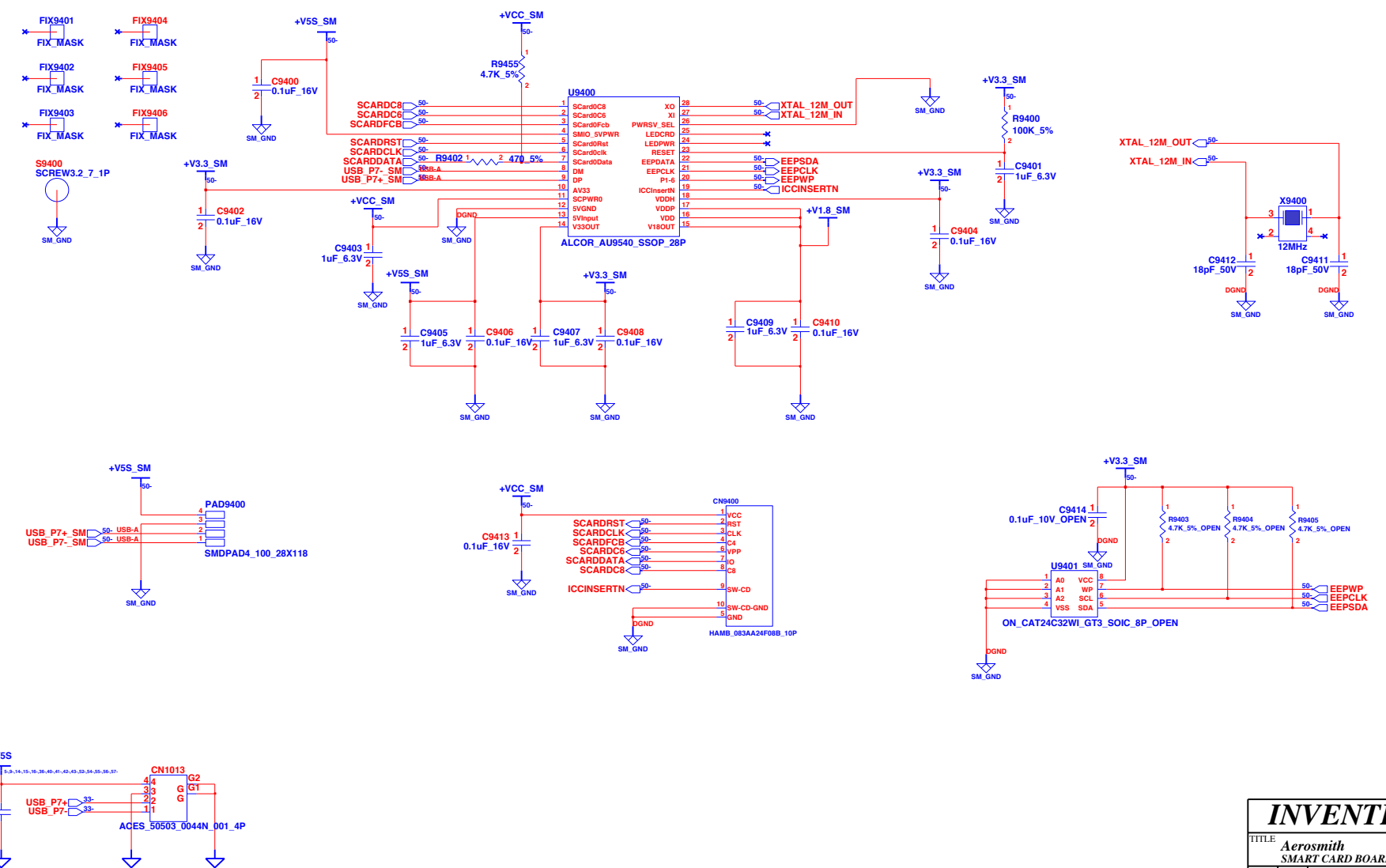

INVENTEC			
TITLE Aerosmith SMART CARD BOARD			
SIZE A3	CODE CS	DOC NUMBER 1310A24383-0-MTR	REV A03
CHANGE by <i>Evon Shih</i>		26-Aug-2011	
SHEET 50		OF 61	

EXPRESS CARD

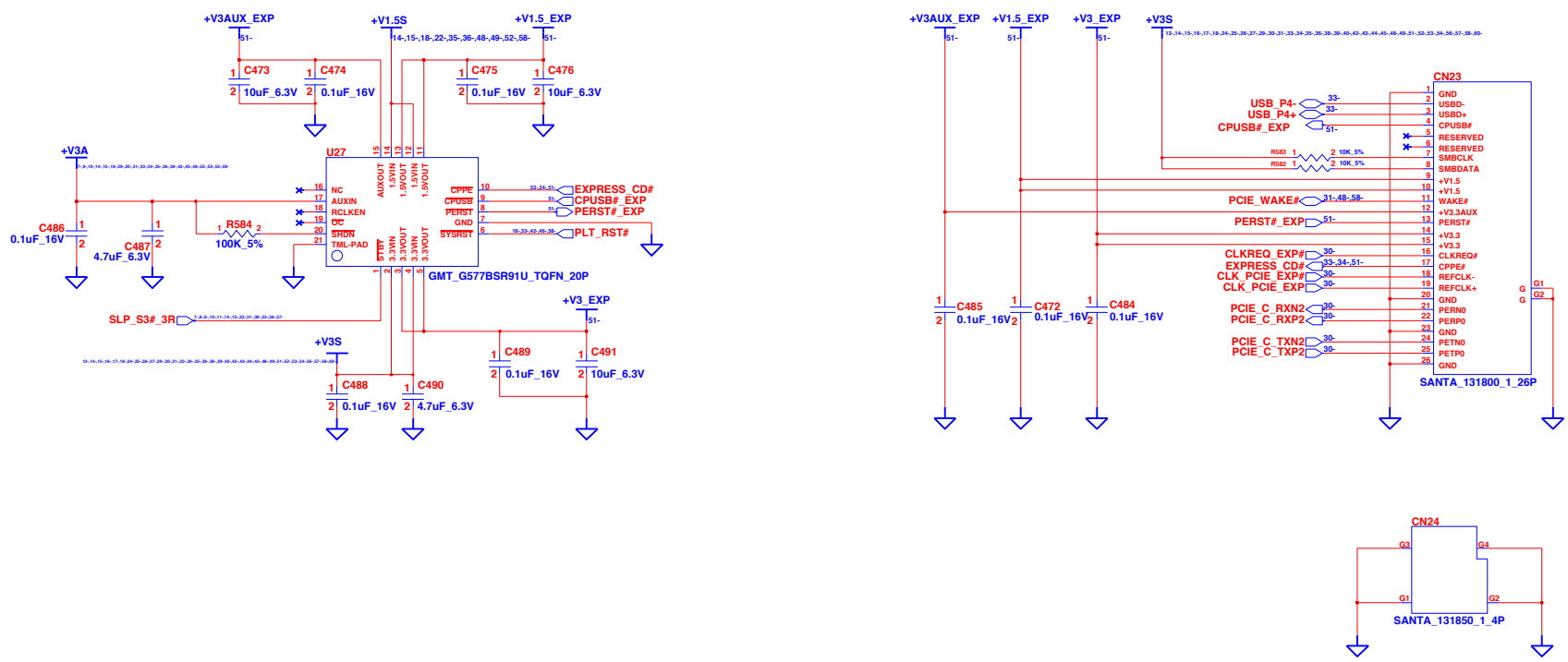

INVENTEC			
TITLE Aerosmith EXPRESS CARD & LED			
SIZE A3	CODE CS	DOC. NUMBER 1310A24383-0-MTR	REV A03
CHANGE by <i>Evon Shih</i>		DATE 26-Aug-2011	
SHEET 51		OF 61	

RF & EMI SOLUTION

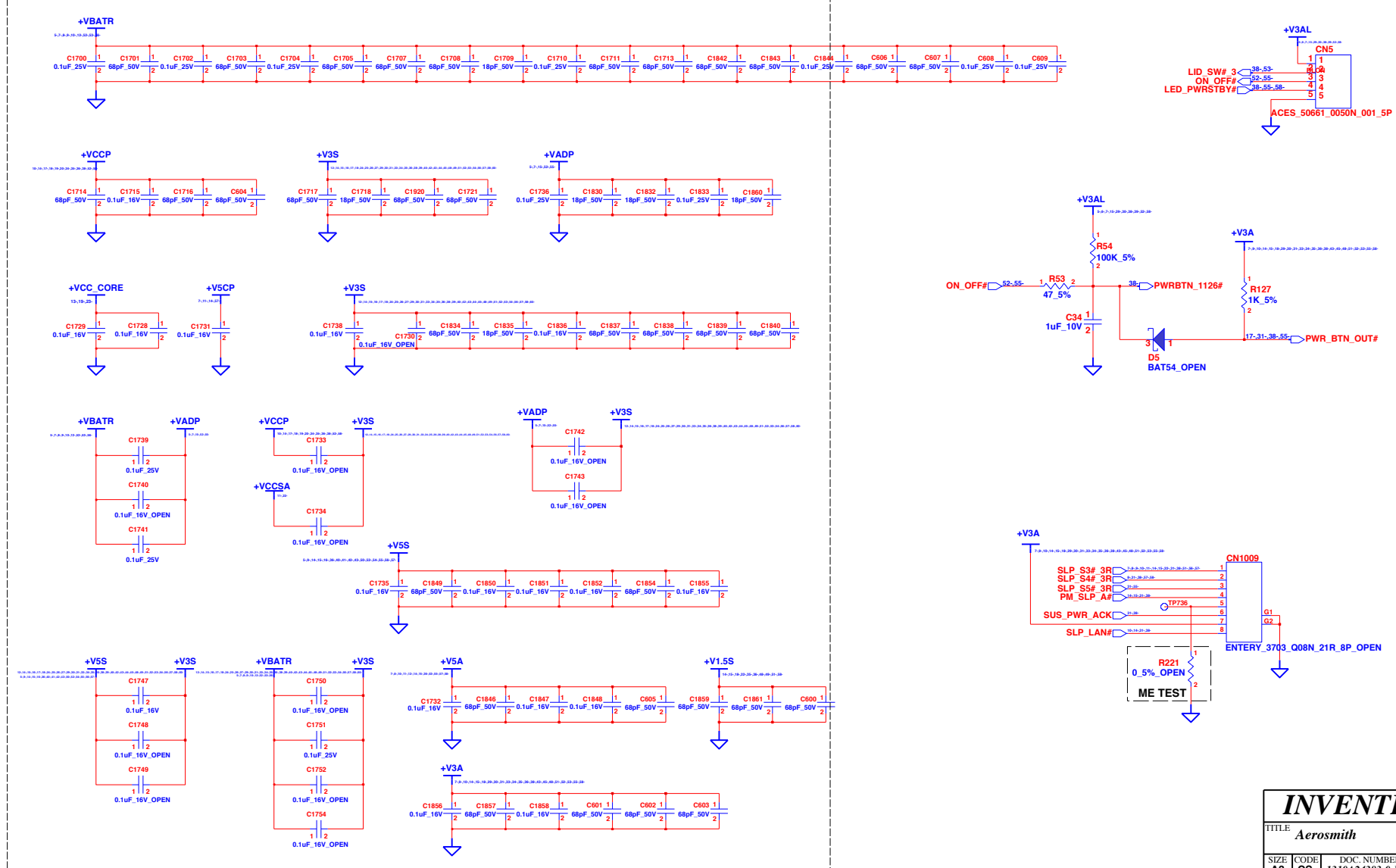

Integrated Panel

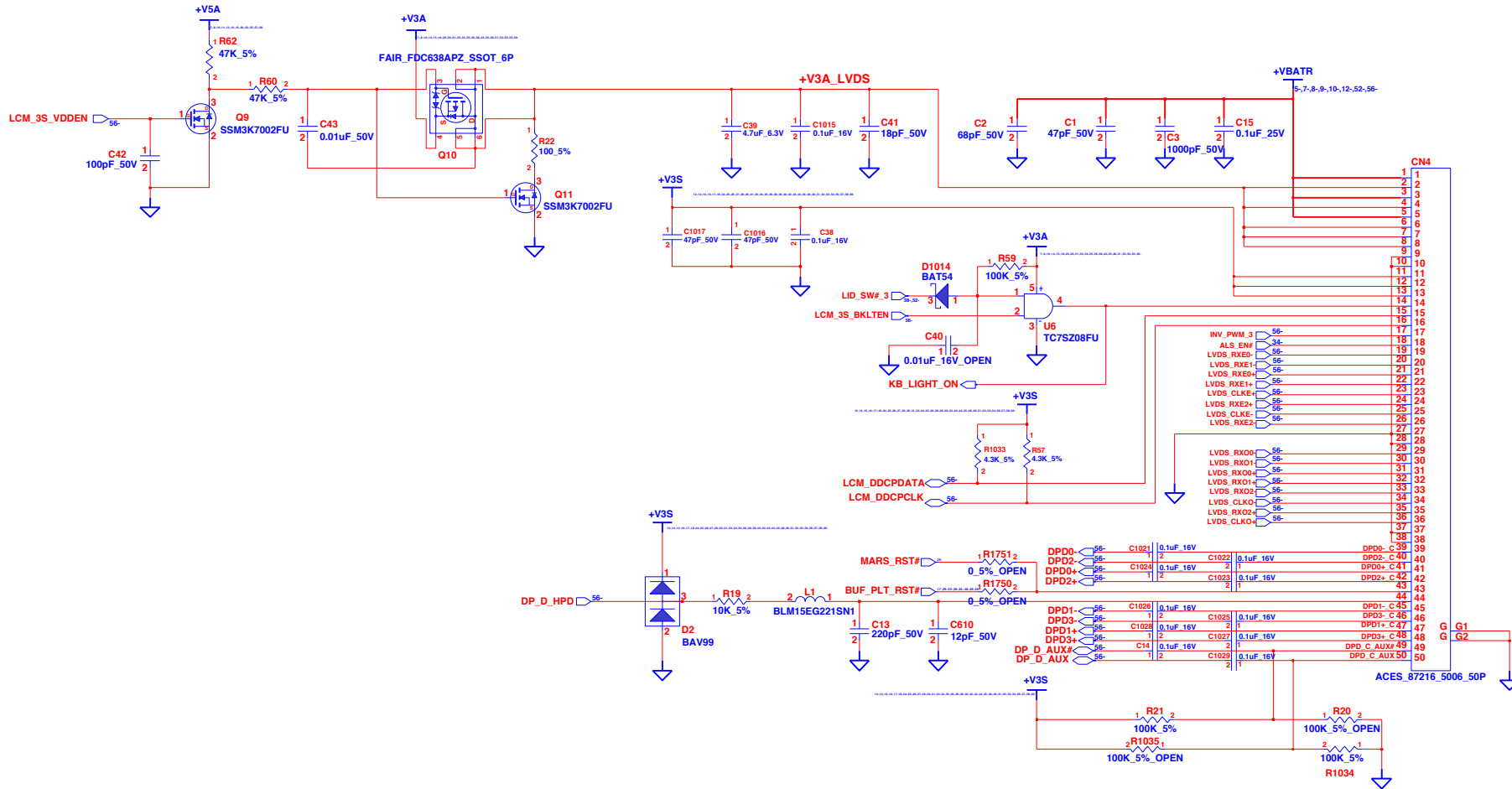

INVENTEC

TITLE			
Aerosmith			
LCM			
SIZE	CODE	DOC. NUMBER	REV
A3	CS	1310A24383-0-MTR	A03
SHEET		53	OF 61

CHANGE by *Evan Shih* 26-Aug-2011

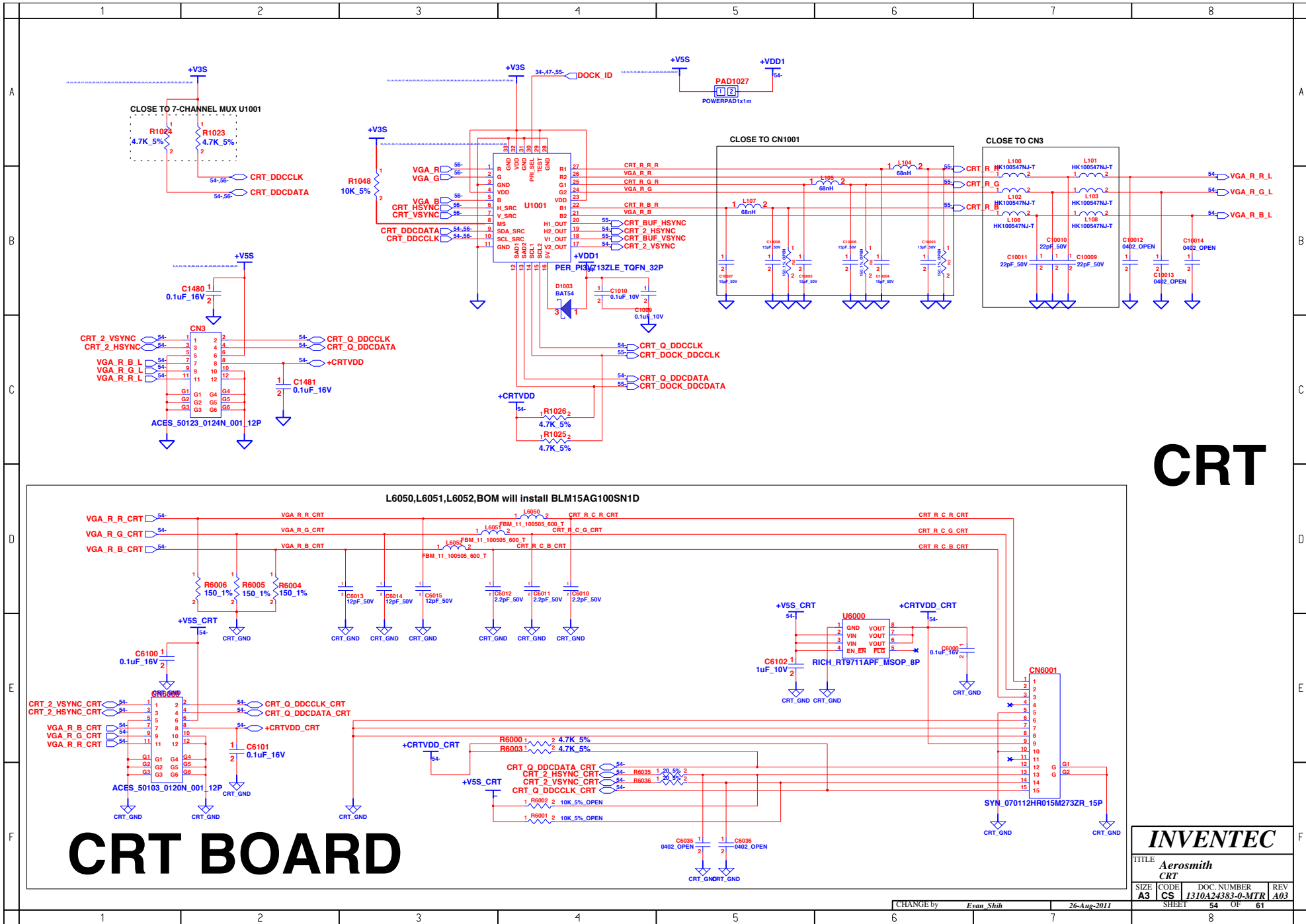

CRT

CRT BOARD

INVENTEC			
TITLE Aerosmith CRT			
SIZE A3	CODE CS	DOC. NUMBER 1310A24383-0-MTR	REV A03
CHANGE by <i>Evan Shih</i>		26-Aug-2011	
SHEET 54		OF 61	

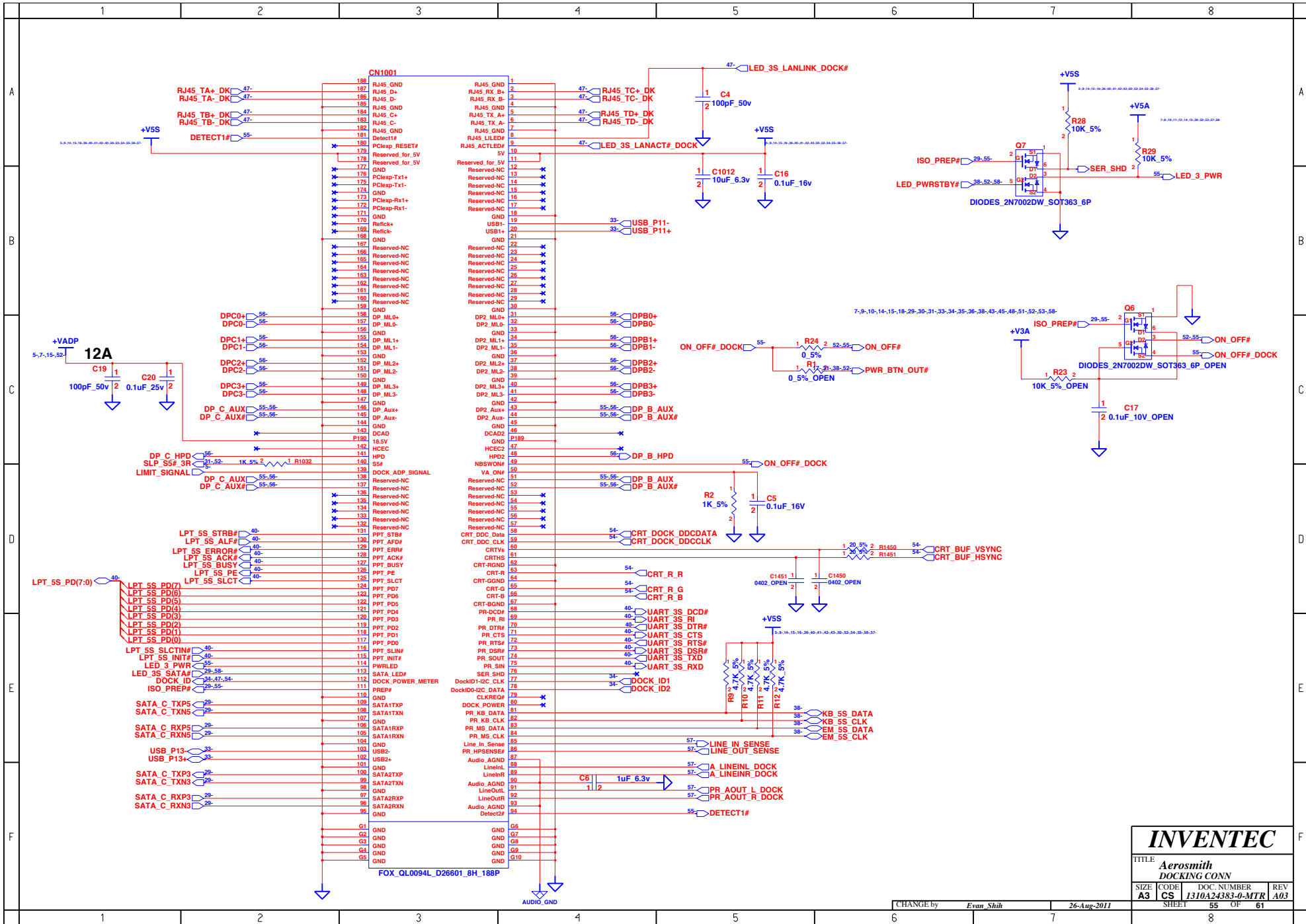

INVENTEC			
TITLE Aerosmith DOCKING CONN			
SIZE A3	CODE CS	DOC. NUMBER 1310A24383-0-MTR	REV A03
SHEET 55		OF 61	

CHANGE by *Evan Shih* 26-Aug-2011

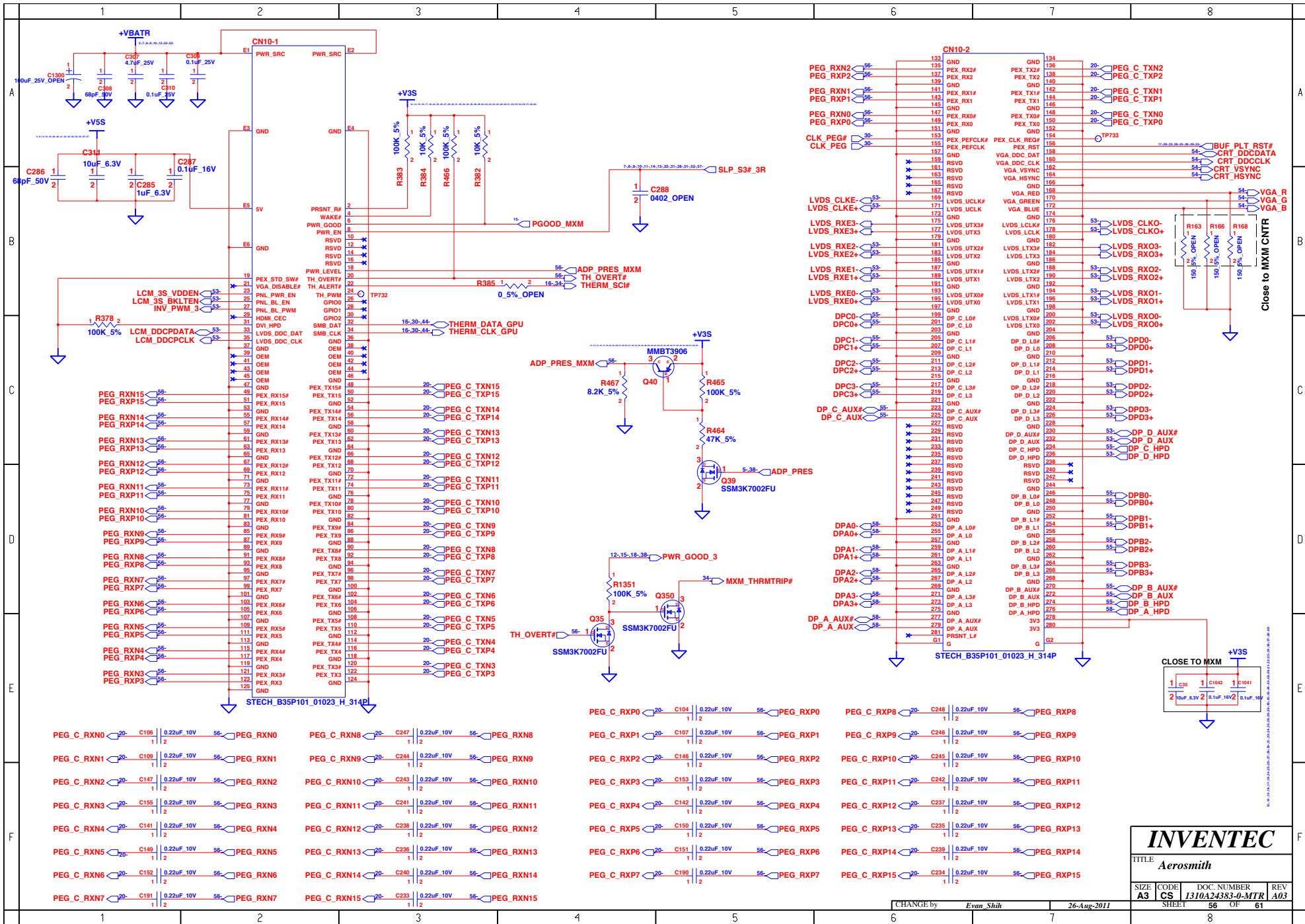

INVENTEC

TITLE
Aerosmith

SIZE A3	CODE CS	DOC. NUMBER 1310A24383-0-MTR	REV A03
SHEET 56		OF 61	

CHANGE by *Evan Shih* 26-Aug-2011

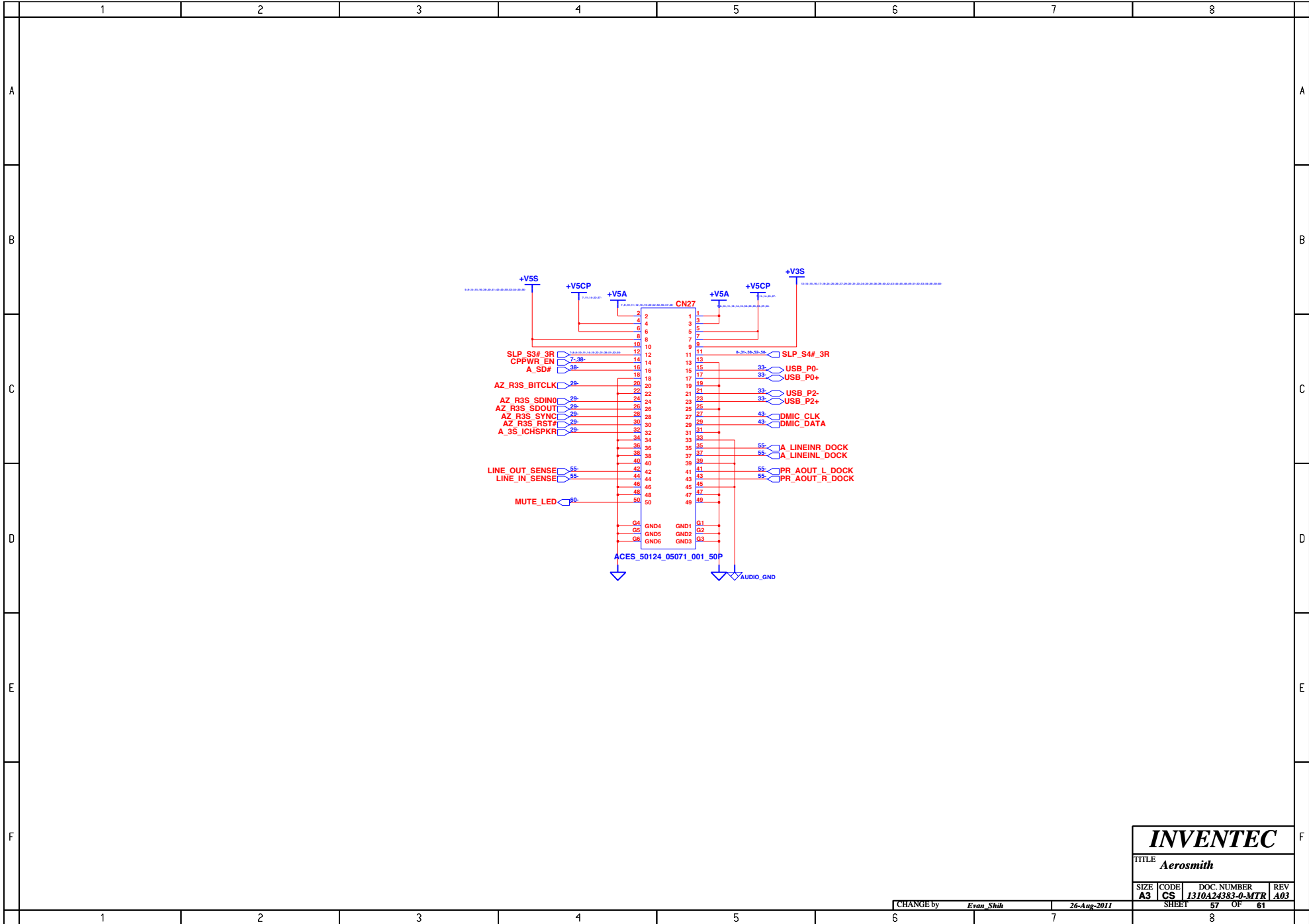

INVENTEC

TITLE
Aerosmith

SIZE A3	CODE CS	DOC. NUMBER 1310A24383-0-MTR	REV A03
SHEET 57		OF 61	

CHANGE by *Evon Shih* 26-Aug-2011

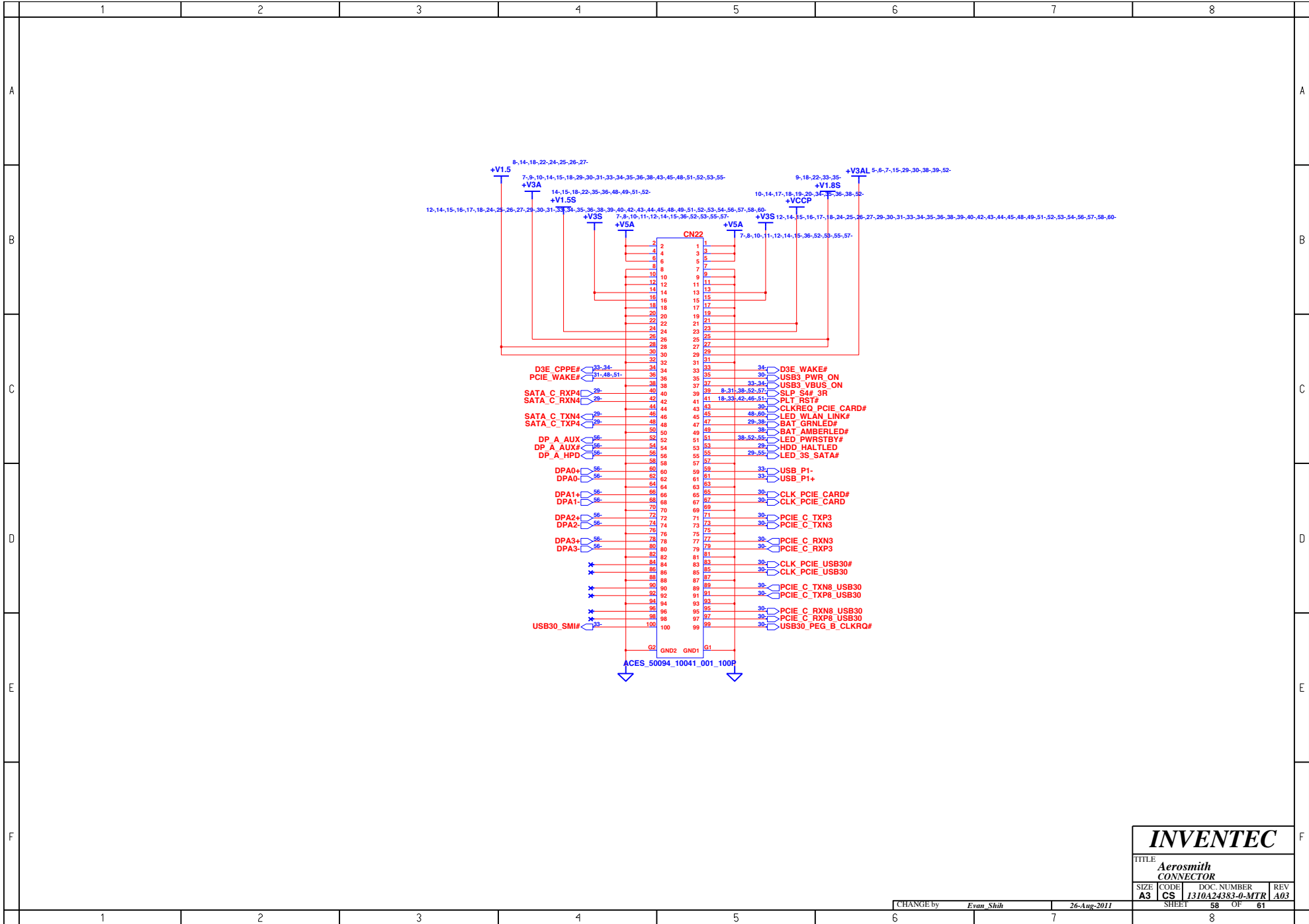

INVENTEC

TITLE			
Aeromith CONNECTOR			
SIZE	CODE	DOC. NUMBER	REV
A3	CS	1310A24383-0-MTR	A03
CHANGE by		DATE	SHEET
Evan Shih		26-Aug-2011	58 OF 61

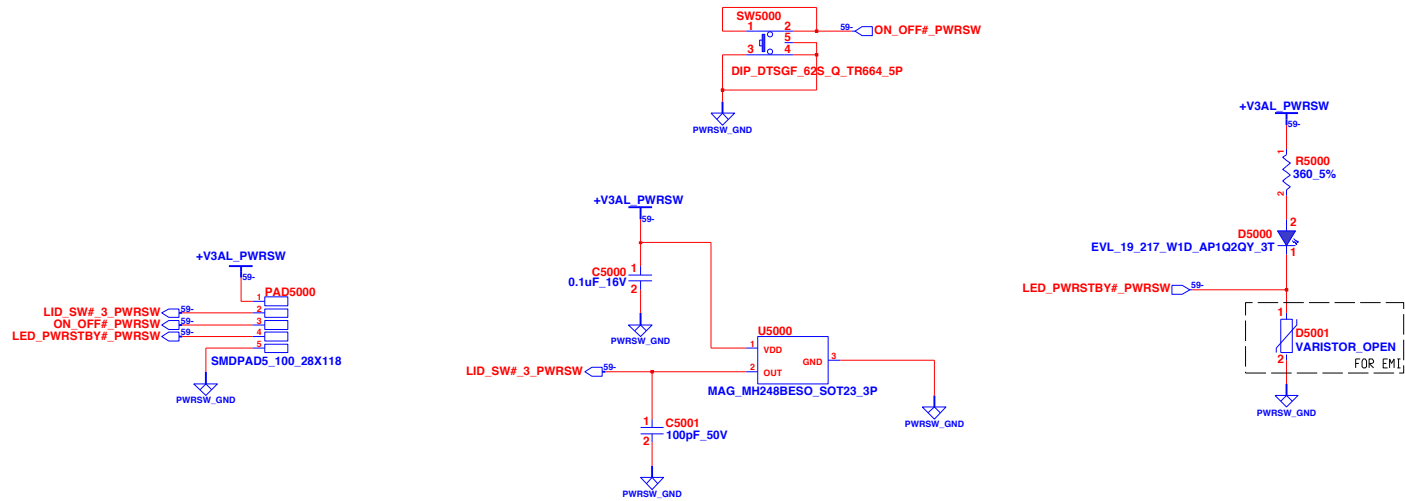

POWER BUTTON & LID SWITCH BOARD

INVENTEC

TITLE			
Aerosmith HALL SENSOR			
SIZE	CODE	DOC. NUMBER	REV
A3	CS	1310A24383-0-MTR	A03
SHEET		OF	
59		61	

CHANGE by *Evon Shih* 26-Aug-2011

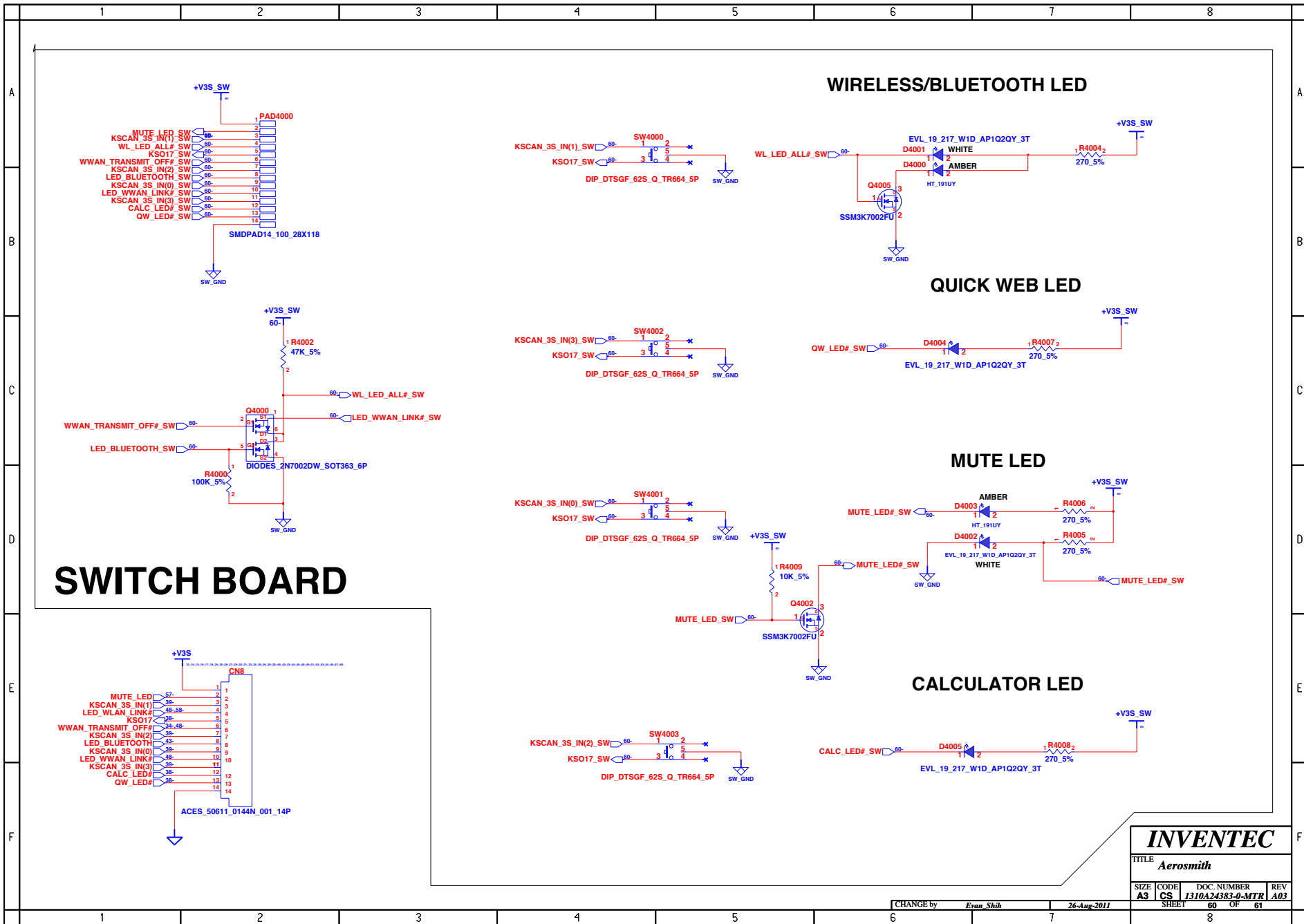

INVENTEC			
TITLE <i>Aerosmith</i>			
SIZE A3	CODE CS	DOC. NUMBER <i>1310A24383-0-MTR</i>	REV A03
CHANGE by <i>Evan Shih</i>		26-Aug-2011	
SHEET 60		OF 61	

SCREW

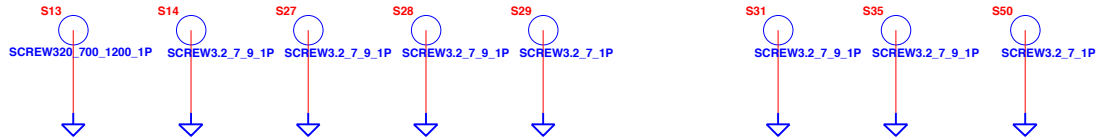
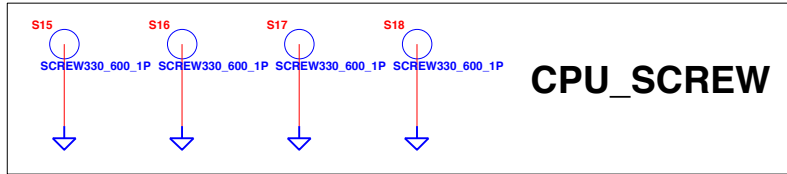
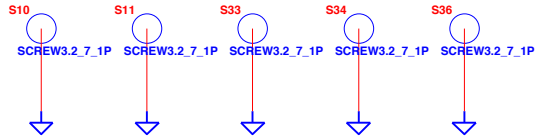

STANDOFF

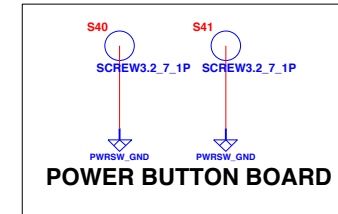
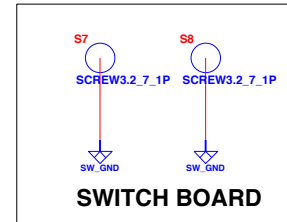
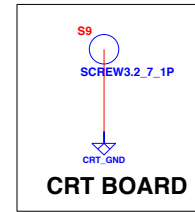
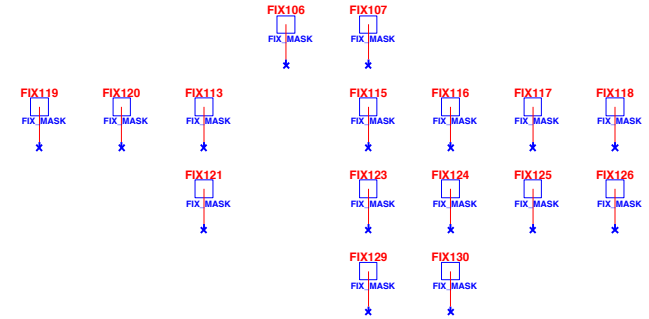
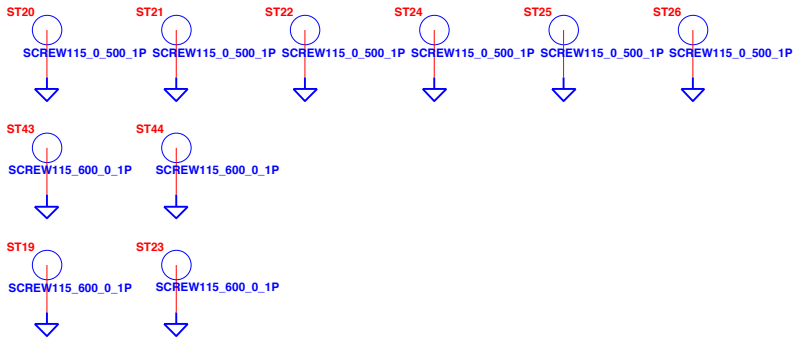

INVENTEC

TITLE			
Aerosmith			
SCREW			
SIZE	CODE	DOC. NUMBER	REV
A3	CS	1310A24383-0-MTR	A03
SHEET		61	OF 61

CHANGE by *Evan Shih* 26-Aug-2011