

Index

PAGE

- 01. PROJECT NAME
- 02. INDEX
- 03. Block Diagram
- 04. POWER Procedure
- 05. DC & CHARGE Circuit
- 06. Battery CONN
- 07. +V3A & +V5A
- 08. +V1.5 & +V0.75
- 09. +V1.8S & +V1.05S
- 10. +VCC_CORE
- 11. +VGFX_CORE
- 12. VTT & VPCIE & VDDC_GPU
- 13. +V5S & +V3S
- 14. CLK GEN
- 15. CPU-1
- 16. CPU-2
- 17. CPU-3
- 18. CPU-4
- 19. CPU-5
- 20. CPU-6
- 21. Thermal, Fan & XDP
- 22. DDR3-1
- 23. DDR3-2
- 24. PCH-1
- 25. PCH-2
- 26. PCH-3
- 27. PCH-4
- 28. PCH-5
- 29. PCH-6
- 30. PCH-7

PAGE

- 31. PCH-8
- 32. PCH-9
- 33. KBC
- 34. Keyboard & TouchPad
- 35. CRT CONN
- 36. LCM CONN
- 37. HDMI CONN
- 38. SATA HDD & ODD
- 39. LAN
- 40. RJ-45
- 41. Card Reader
- 42. Audio Codec
- 43. HP JACK & MIC JACK
- 44. ESATA, SCREW
- 45. WLAN & BlueTooth
- 46. USB, PowerButton(DB)
- 47. WWAN(Optional)
- 48. FP & HD LOCK(Optional)
- 49. PARK-S3 PCIE INTERFACE
- 50. PARK-S3 Display and GIPO INTERFACE
- 51. PARK-S3 CLK and DDC INTERFACE
- 52. PARK-S3 POWER INTERFACE
- 53. PARK-S3 DP Power and LVDS INTERFACE
- 54. PARK-S3 Memory INTERFACE
- 55. VRAM-1(DDR3)
- 56. VRAM-2(DDR3)

INVENTEC

TITLE			
<i>ST133iD</i>			
<i>Index</i>			
SIZE	CODE	DOC. NUMBER	REV
A3	CS	1310A23179-0-MTR	B
SHEET		2	OF 58

Inventec Confidential

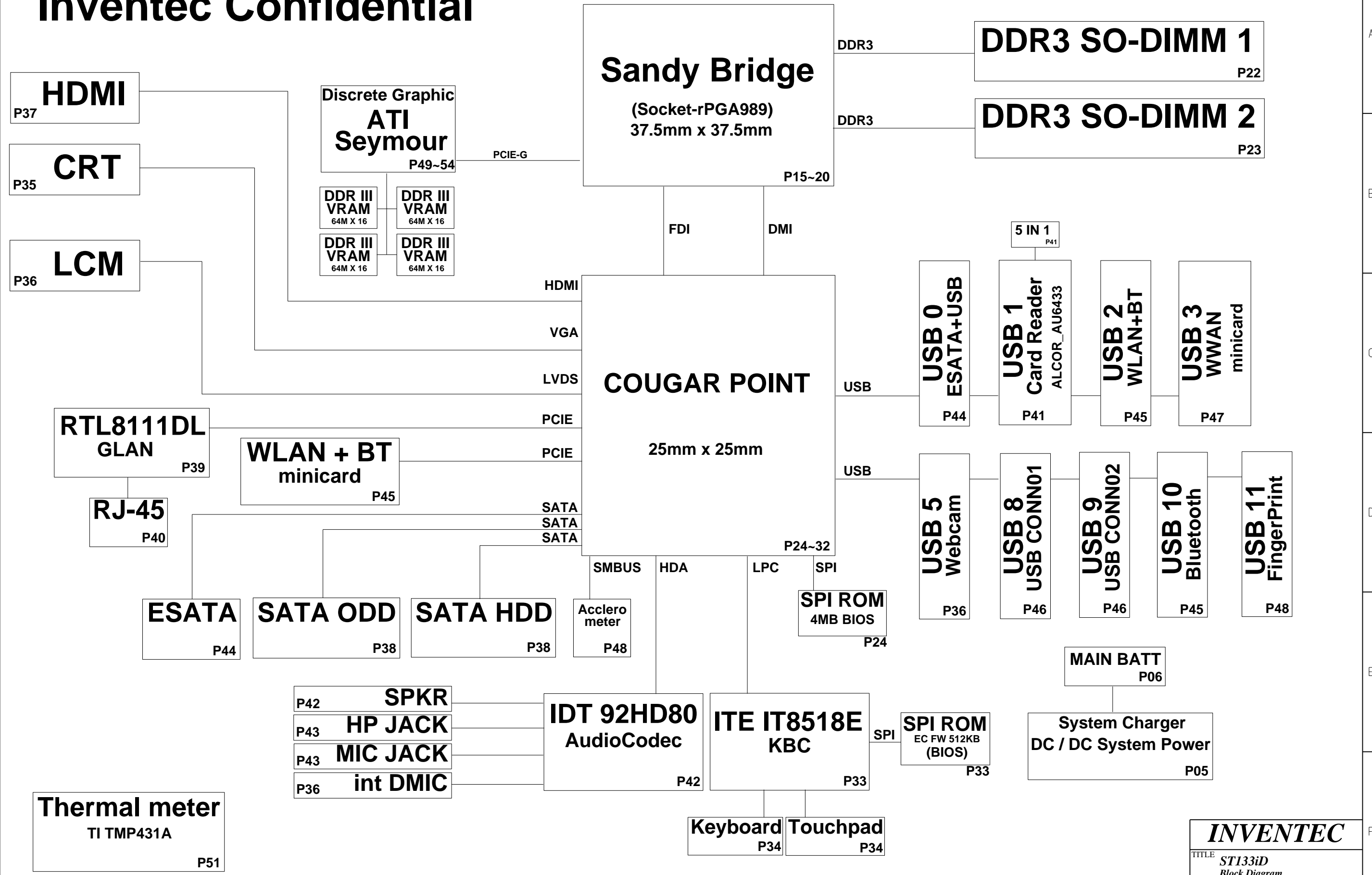

INVENTEC			
TITLE ST133iD			
Block Diagram			
SIZE	CODE	DOC. NUMBER	REV
A3	CS	1310A23179-0-MTR	B
CHANGE by		SHEET	
Chang, Sukigo		3 OF 58	

29-Jun-2010

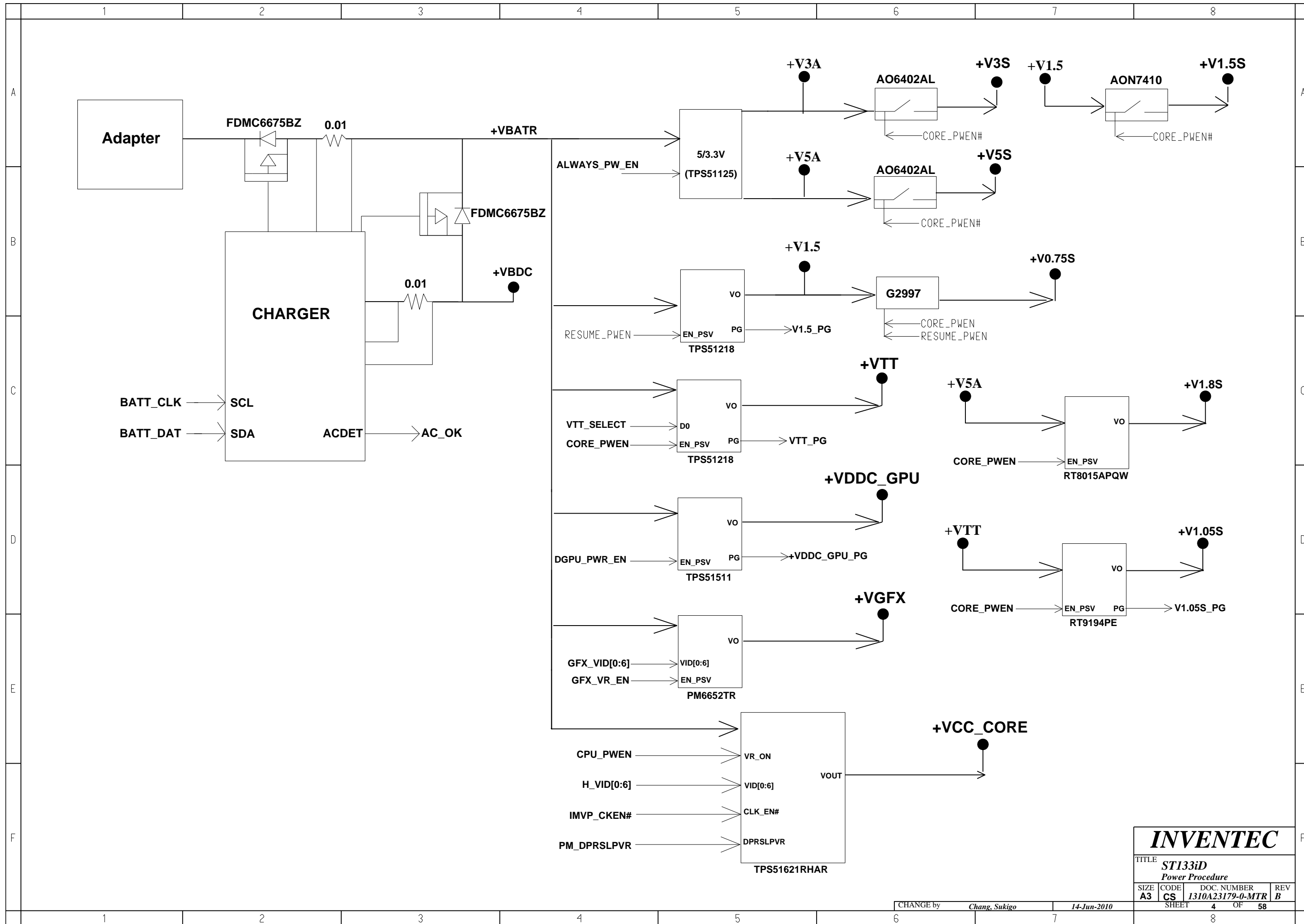

INVENTEC			
TITLE ST133iD			
Power Procedure			
SIZE	CODE	DOC. NUMBER	REV
A3	CS	1310A23179-0-MTR	B
CHANGE by		SHEET	
Chang, Sukigo		4 OF 58	
		14-Jun-2010	

AC-IN

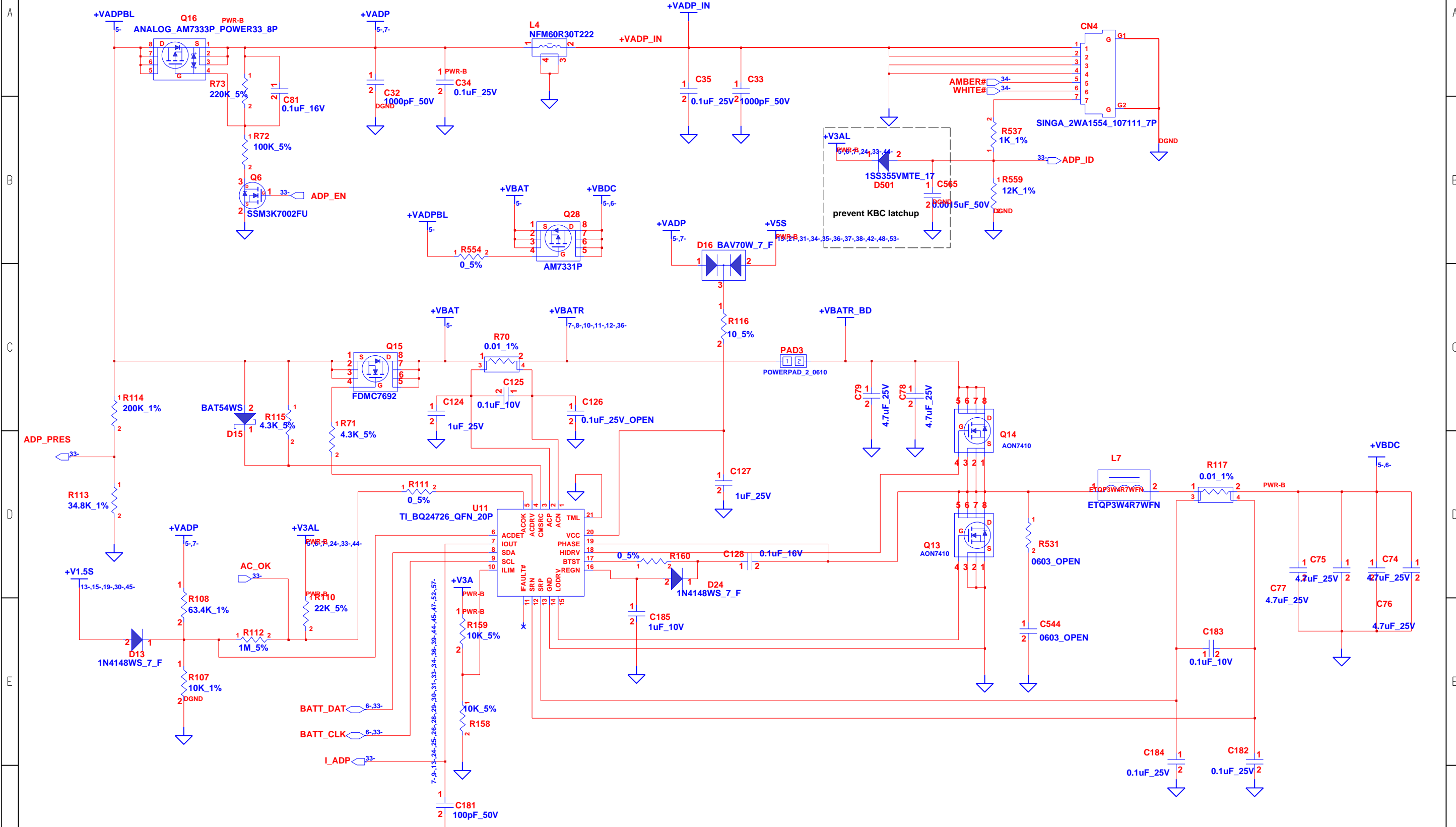

INVENTEC			
TITLE ST133iD			
DC & Battery Charger			
SIZE A3	CODE CS	DOC. NUMBER I310A23179-0-MTR	REV B
CHANGE by <i>Chang, Sukigo</i>		14-Jun-2010	
SHEET 5		OF 58	

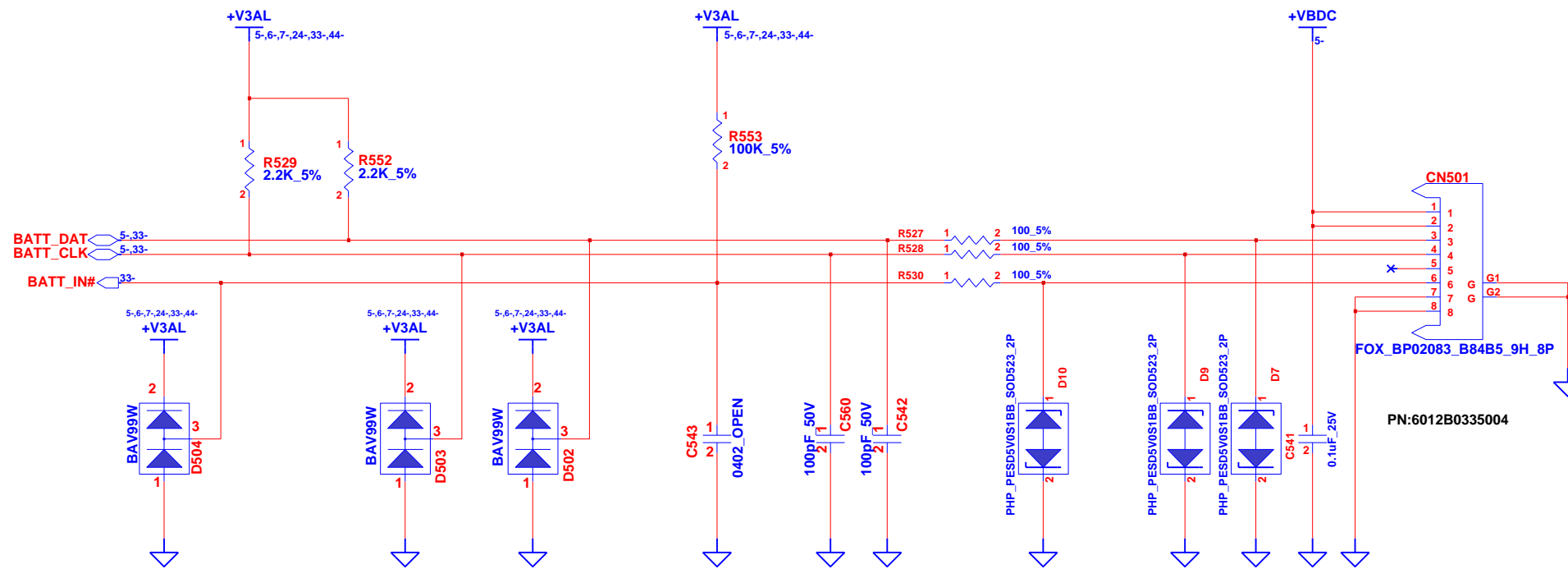

INVENTEC

TITLE **ST133iD**
Battery CONN

SIZE	CODE	DOC. NUMBER	REV
A3	CS	1310A23179-0-MTR	B

CHANGE by *Chang, Sukigo* 14-Jun-2010

SHEET 6 OF 58

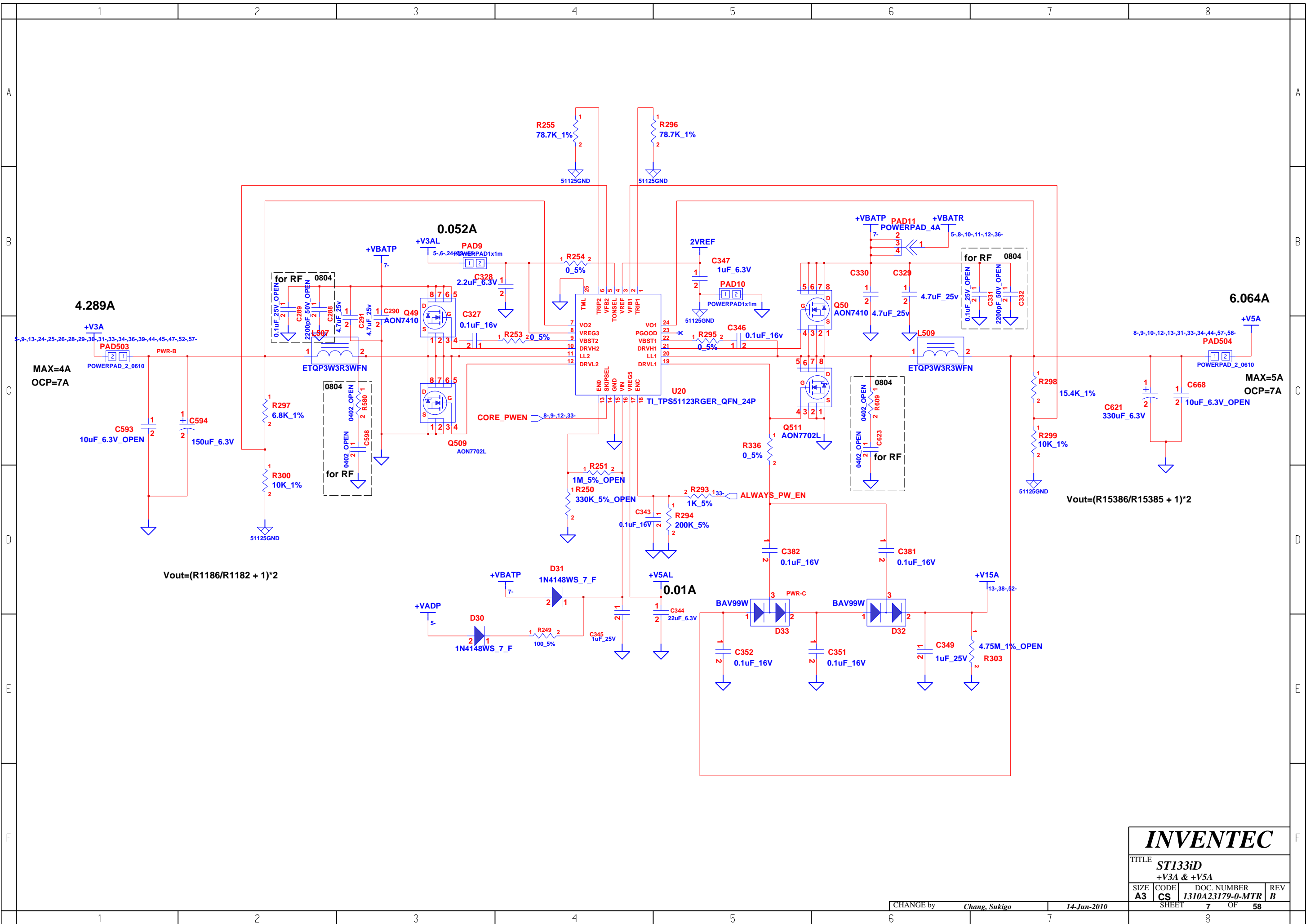

INVENTEC

TITLE			
ST133iD			
+V3A & +V5A			
SIZE	CODE	DOC. NUMBER	REV
A3	CS	1310A23179-0-MTR	B
SHEET		7	OF 58

CHANGE by Chang, Sukigo 14-Jun-2010

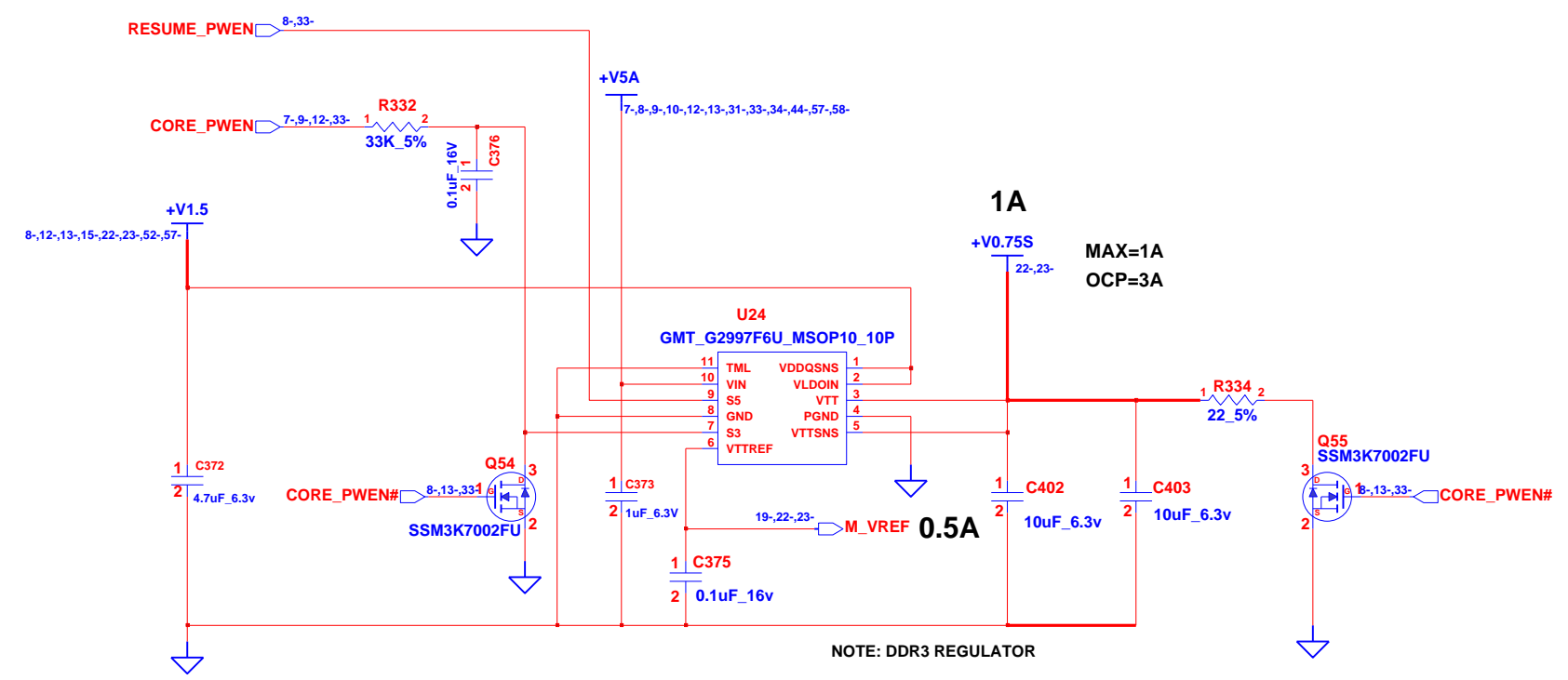
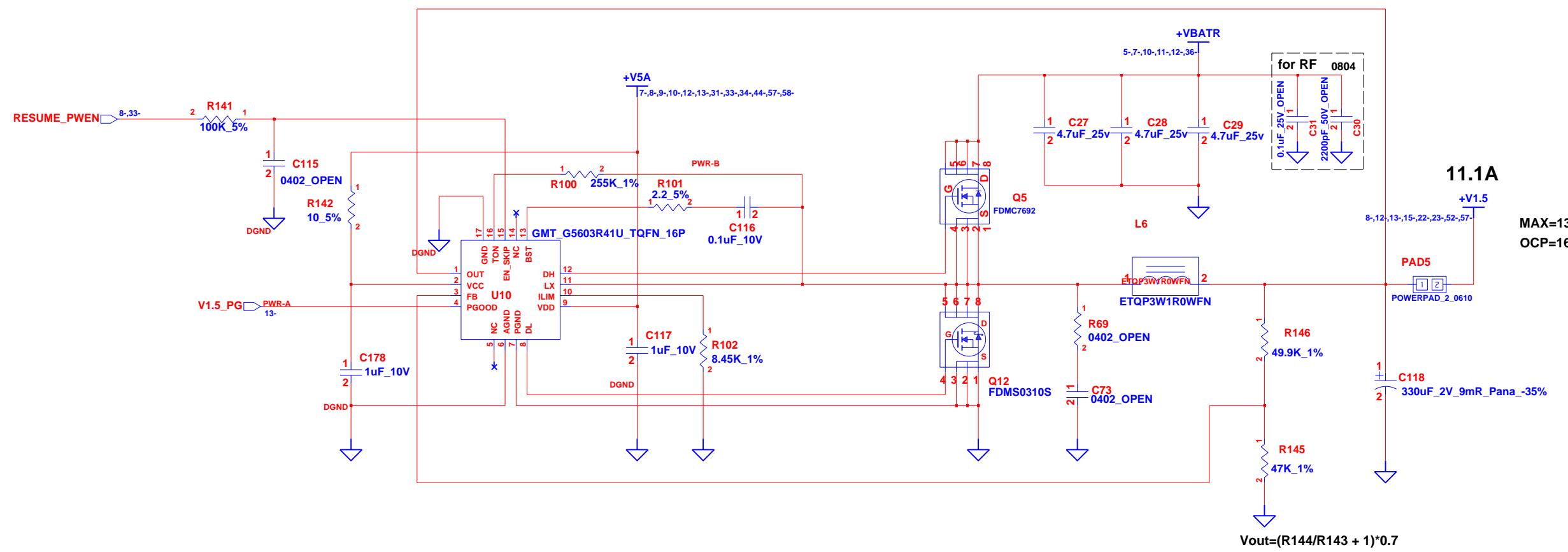

INVENTEC			
TITLE ST133iD			
+V1.5 & +V0.75			
SIZE A3	CODE CS	DOC. NUMBER 1310A23179-0-MTR	REV B
CHANGE by <i>Chang, Sukigo</i>		14-Jun-2010	
SHEET 8		OF 58	

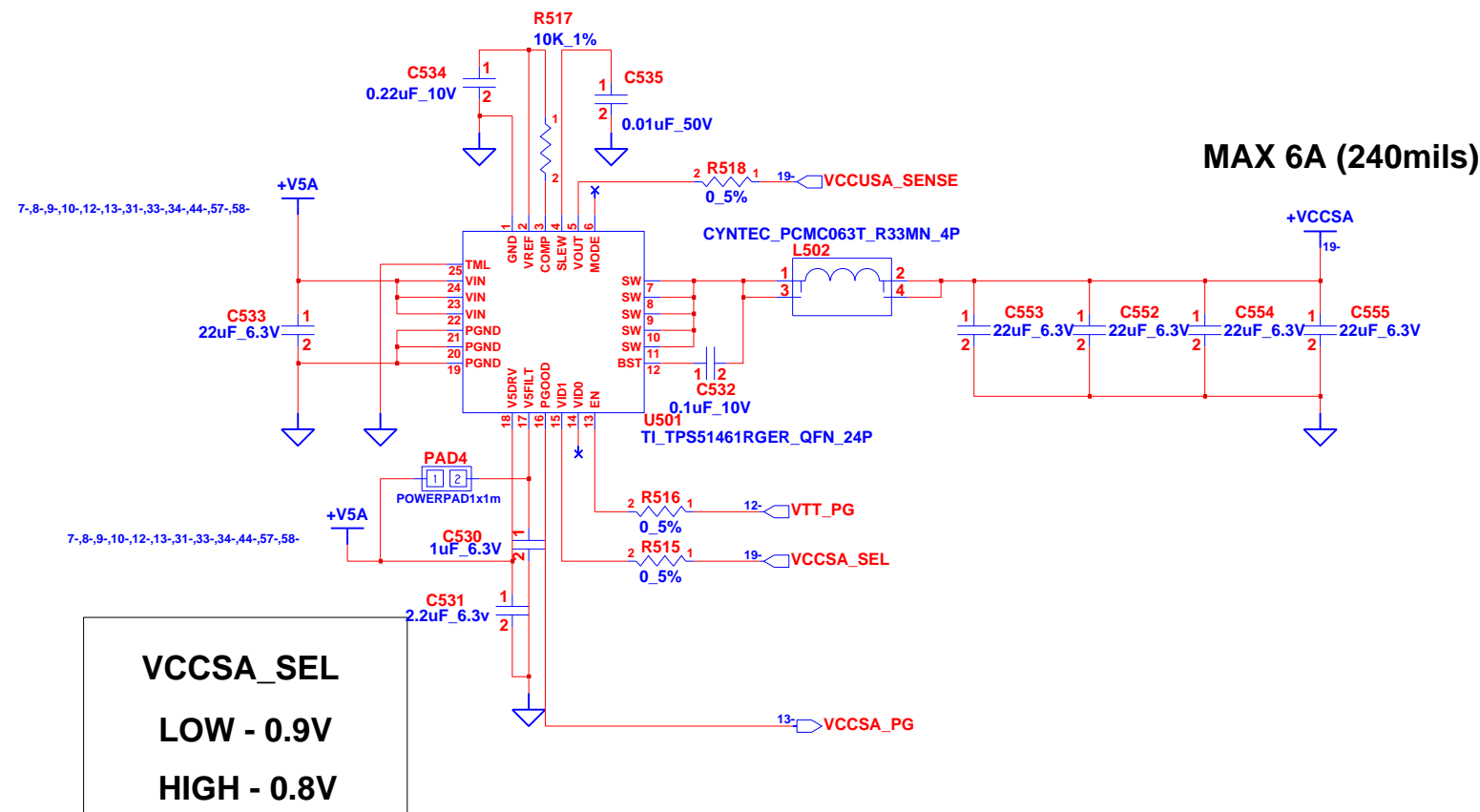
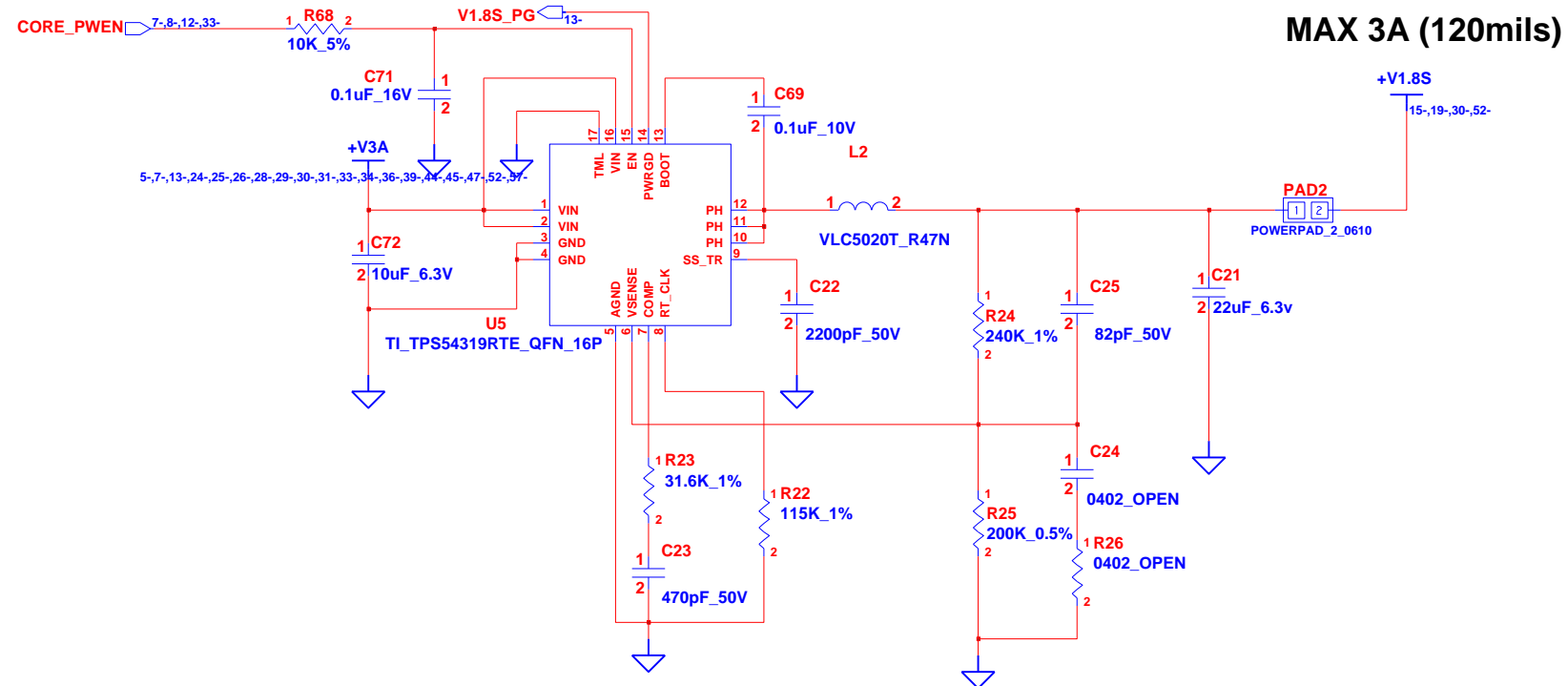

VCCSA_SEL
LOW - 0.9V
HIGH - 0.8V

INVENTEC

TITLE			
ST133iD			
+V1.8S & +VCCSA			
SIZE	CODE	DOC. NUMBER	REV
A3	CS	1310A23179-0-MTR	B
SHEET		9	OF 58

CHANGE by Chang, Sukigo 14-Jun-2010

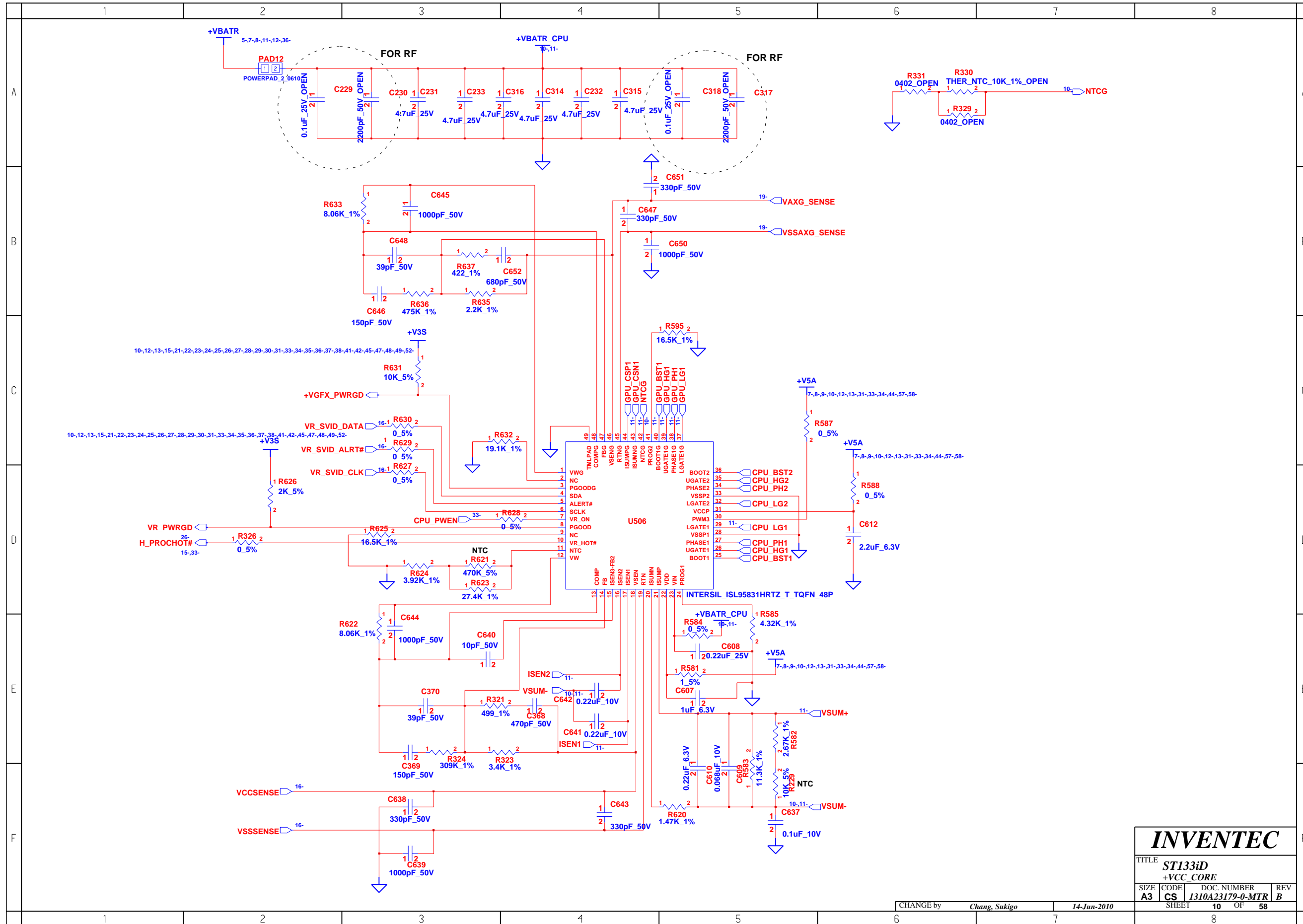

INVENTEC			
TITLE ST133iD +VCC_CORE			
SIZE A3	CODE CS	DOC. NUMBER 1310A23179-0-MTR	REV B
CHANGE by Chang, Sukigo		DATE 14-Jun-2010	SHEET 10 OF 58

VCC_CORE (SV 35W-->MAX 53A)
(Quad 45W-->MAX 94A)

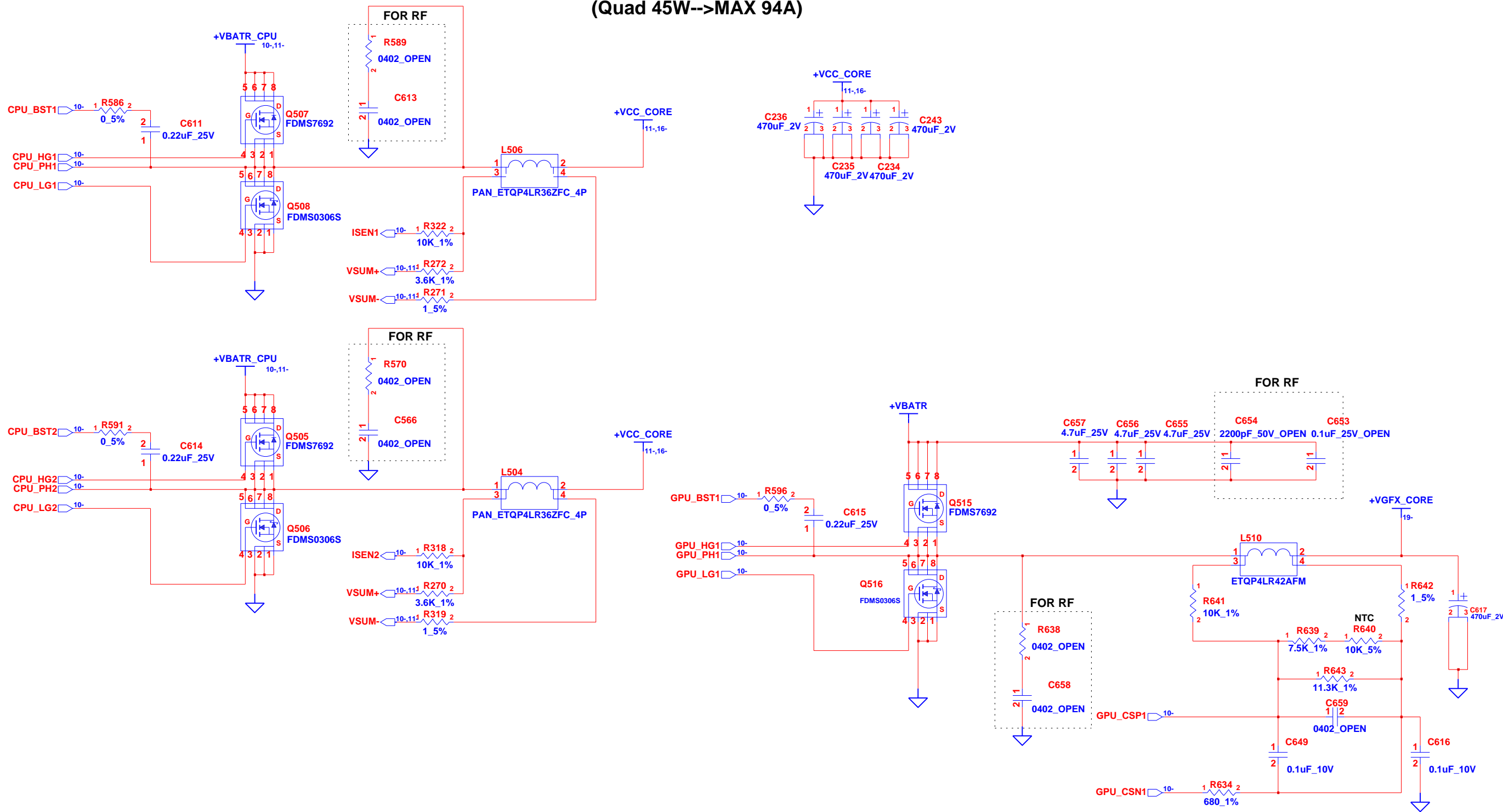

INVENTEC			
TITLE ST133iD			
+VGFX_CORE			
SIZE	CODE	DOC. NUMBER	REV
A3	CS	1310A23179-0-MTR	B
CHANGE by		SHEET	
Chang, Sukigo		11 OF 58	
		14-Jun-2010	

+V1.0S
+VPCIE 2.805A

$$V_{out} = (R_{89}/R_{90} + 1) * 0.757$$

MAX=2A
OCP=2.5A

POW_SW1	POW_SW0	+VDDC_GPU	Rtop	Rbot
0	0	1.1V	R50	R55 // R54
0	1	1V	R50	R55
1	0	0.95V	R50 // R91	R55 // R54
1	1	0.9V	R50 // R91	R55

16.12A

+VDDC_GPU

MAX=11A
OCP=18A

$$V_{out} = (R_{top}/R_{bot} + 1) * 0.75$$

MAX 14.5A(580mils)

INVENTEC

TITLE
ST133iD
Reserve Page

SIZE	CODE	DOC. NUMBER	REV
A3	CS	I310A23179-0-MTR	B

CHANGE by Chang, Sukigo 14-Jun-2010

SHEET 12 OF 58

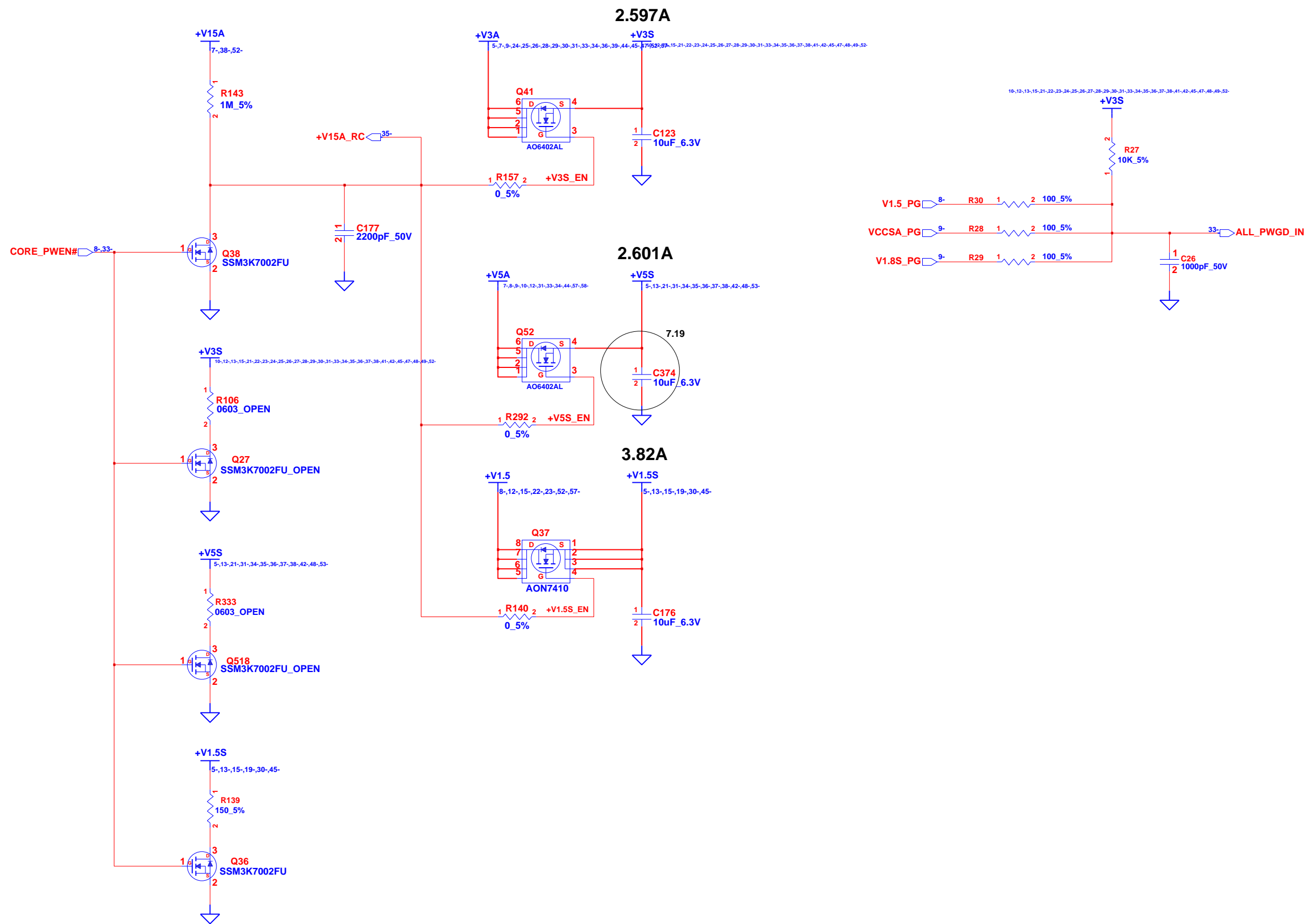

INVENTEC			
TITLE ST133iD			
+V5S & +V3S			
SIZE	CODE	DOC. NUMBER	REV
A3	CS	1310A23179-0-MTR	B
CHANGE by		SHEET	
Chang, Sukigo		13 OF 58	
		14-Jun-2010	

BLANK

INVENTEC

TITLE **ST133iD
CLK GEN**

SIZE	CODE	DOC. NUMBER	REV
A3	CS	1310A23179-0-MTR	B

CHANGE by *Chang, Sukigo* 21-Jun-2010

SHEET 14 OF 58

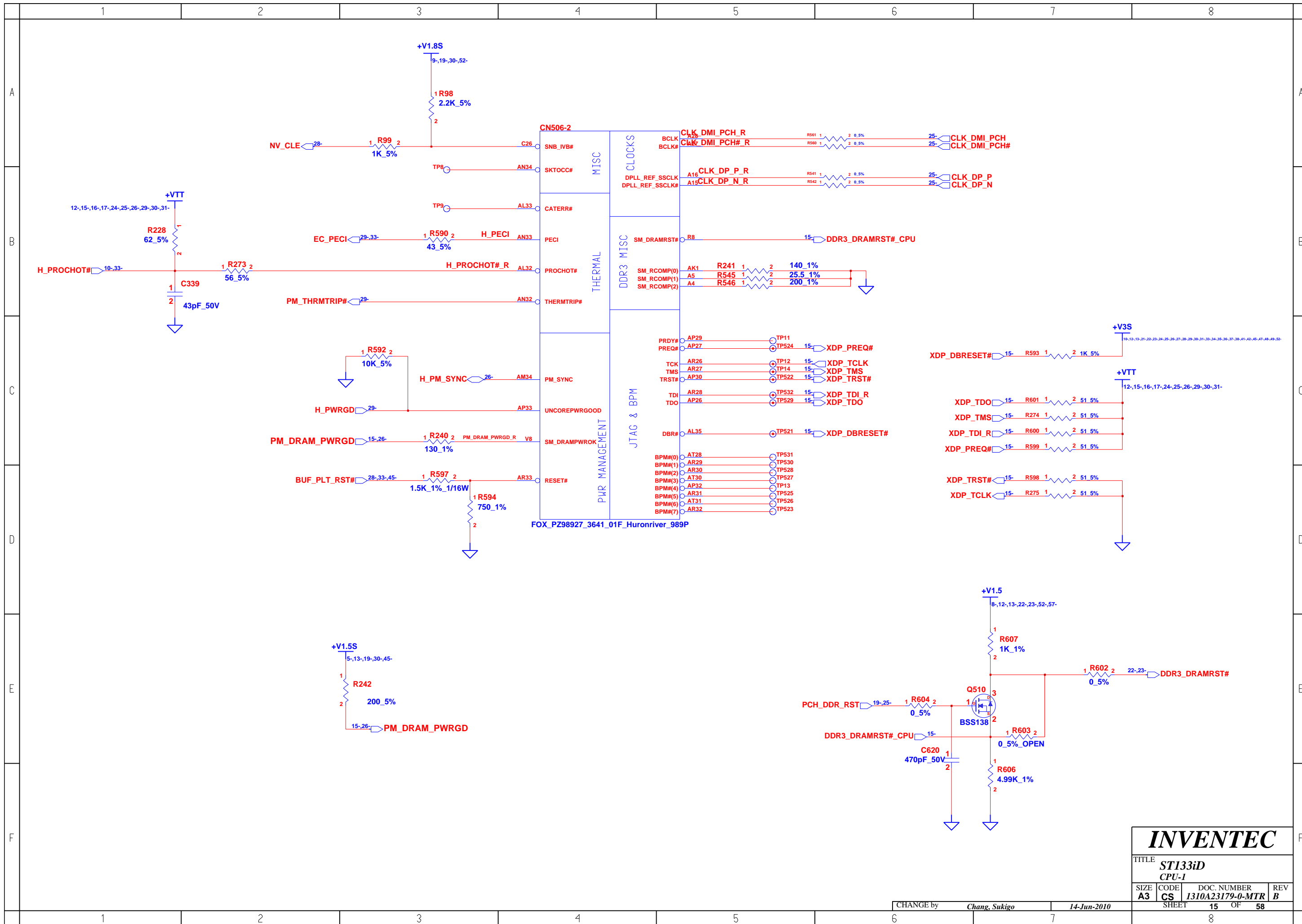

INVENTEC			
TITLE ST133iD			
CPU-1			
SIZE A3	CODE CS	DOC. NUMBER 1310A23179-0-MTR	REV B
CHANGE by <i>Chang, Sukigo</i>		14-Jun-2010	
SHEET 15		OF 58	

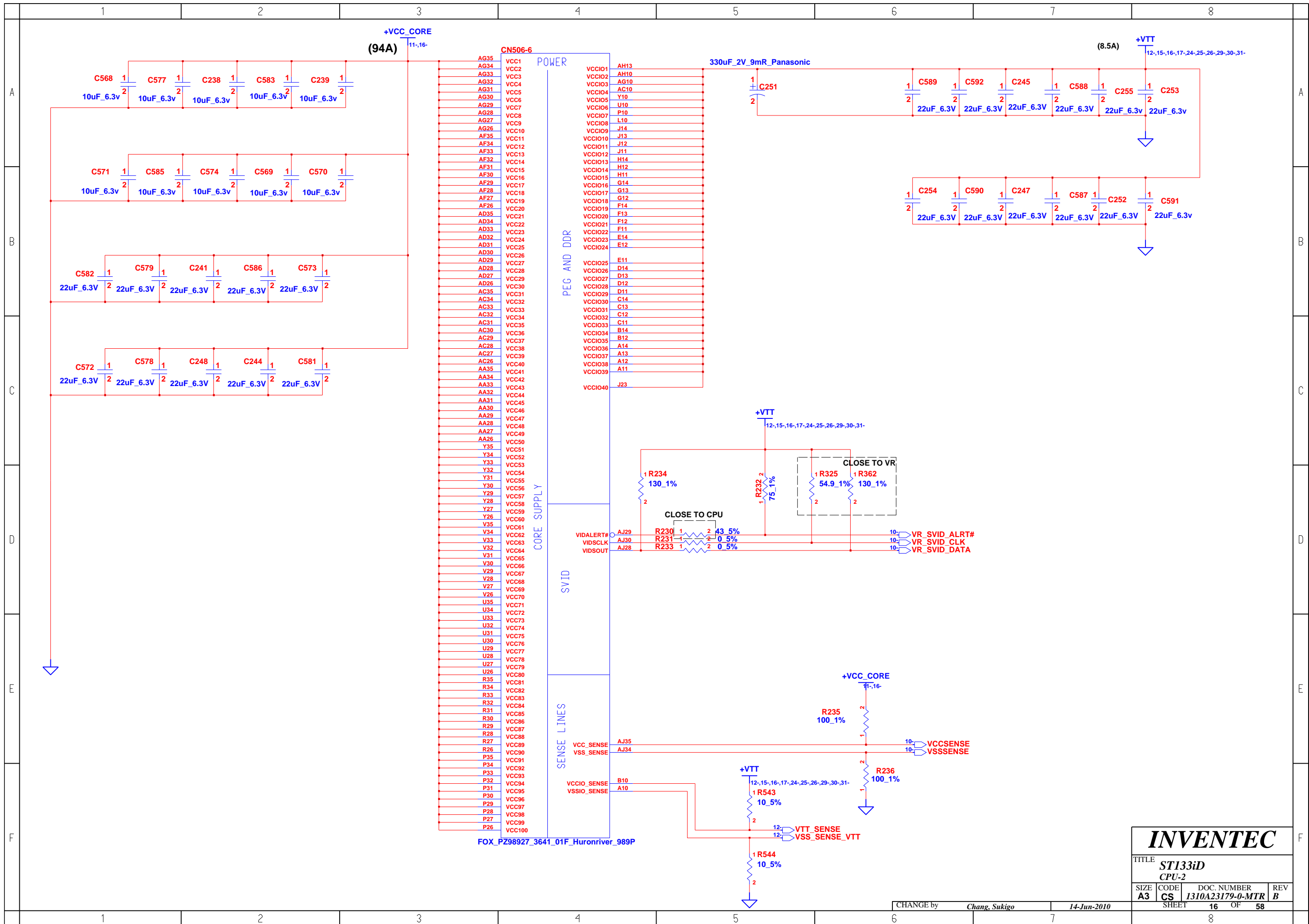

INVENTEC			
TITLE ST133iD CPU-2			
SIZE A3	CODE CS	DOC. NUMBER I310A23179-0-MTR	REV B
CHANGE by <i>Chang, Sukigo</i>		DATE 14-Jun-2010	
SHEET 16		OF 58	

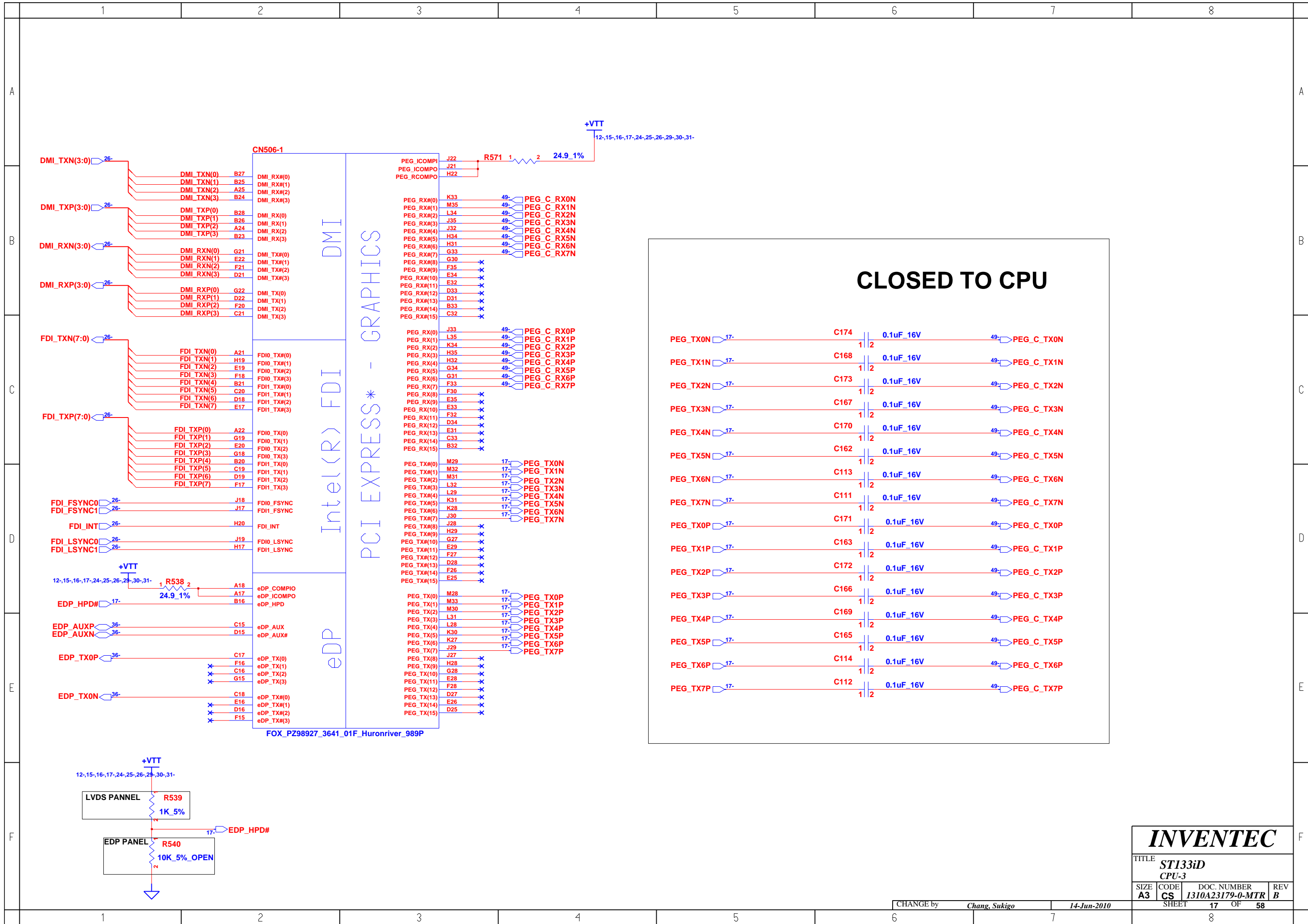

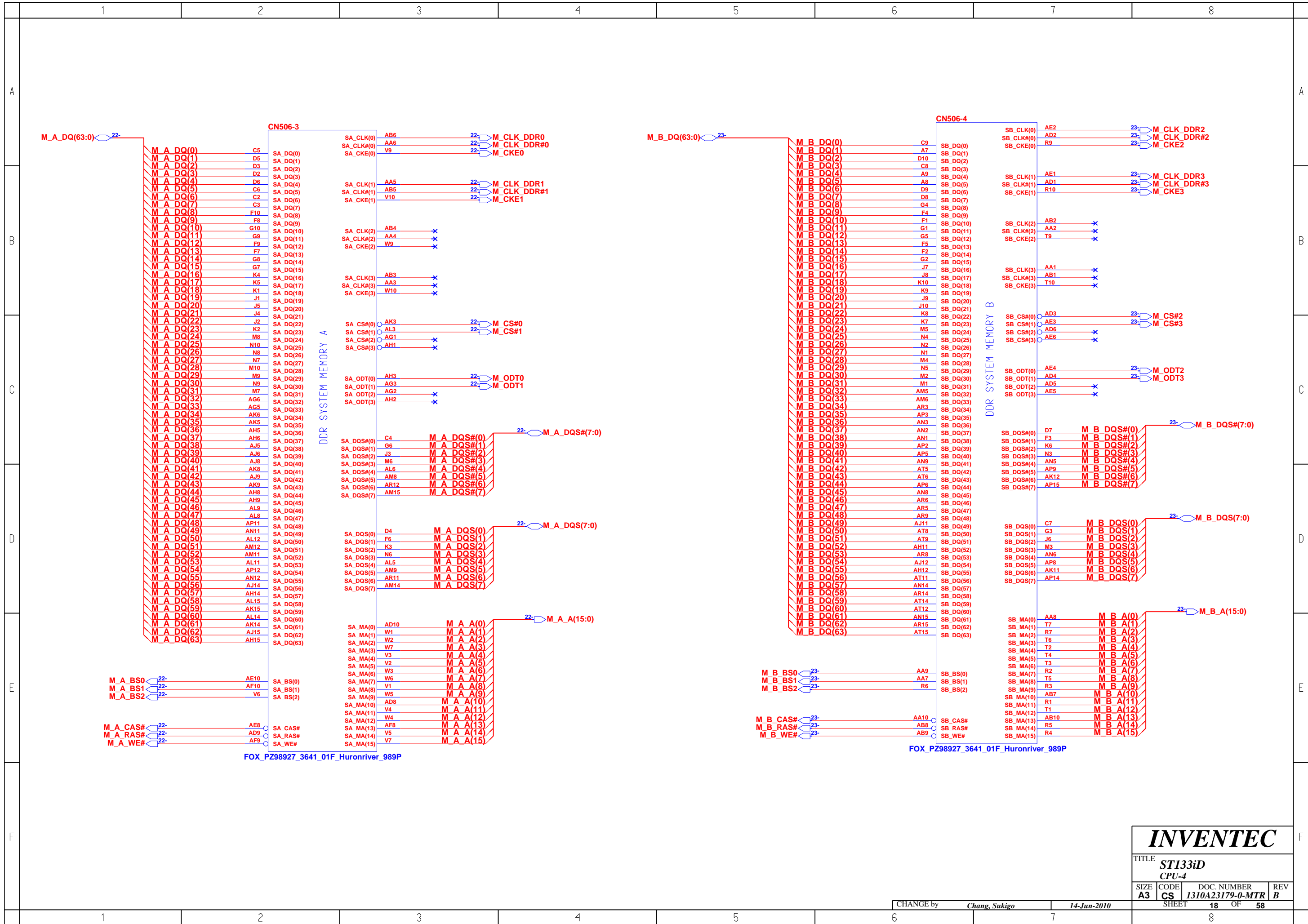

INVENTEC			
TITLE ST133iD			
CPU-4			
SIZE	CODE	DOC. NUMBER	REV
A3	CS	1310A23179-0-MTR	B
CHANGE by <i>Chang, Sukigo</i>		14-Jun-2010	SHEET 18 OF 58

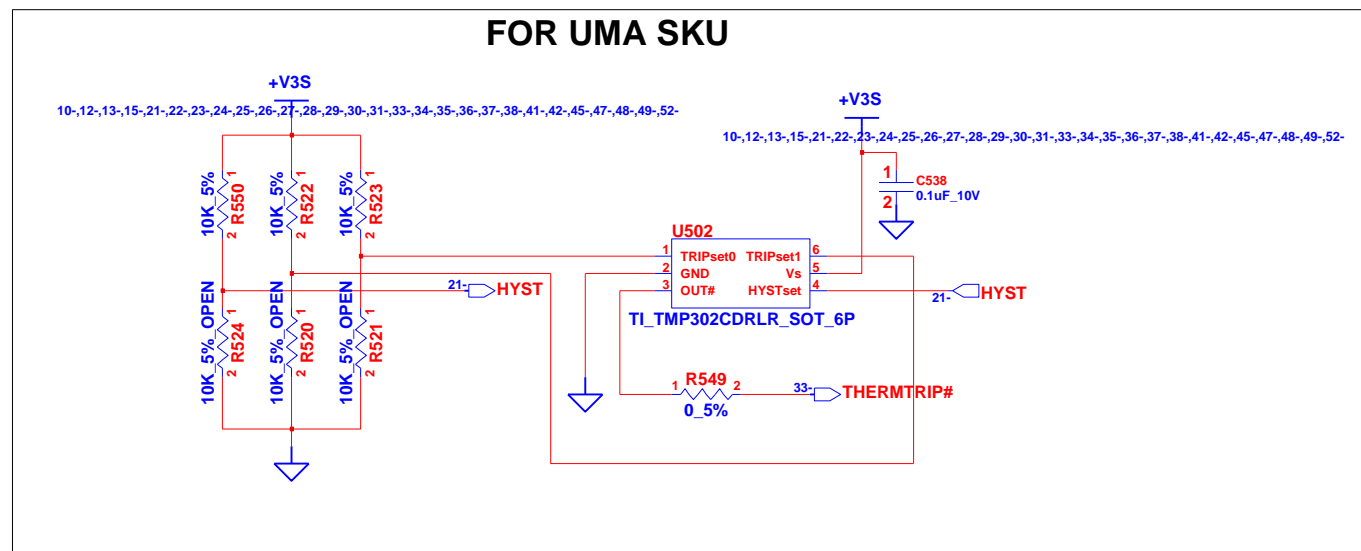
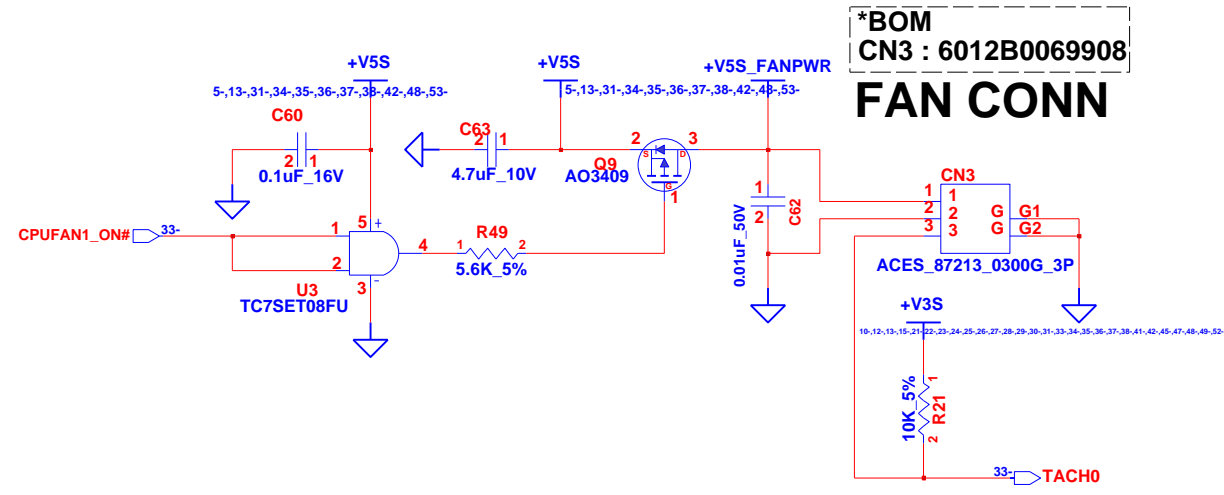

INVENTEC

TITLE			
ST133iD			
Thermal, Fan & XDP			
SIZE	CODE	DOC. NUMBER	REV
A3	CS	1310A23179-0-MTR	B
SHEET		21	OF 58

CHANGE by *Chang, Sukigo* 14-Jun-2010

DDR3 SO-DIMM 1

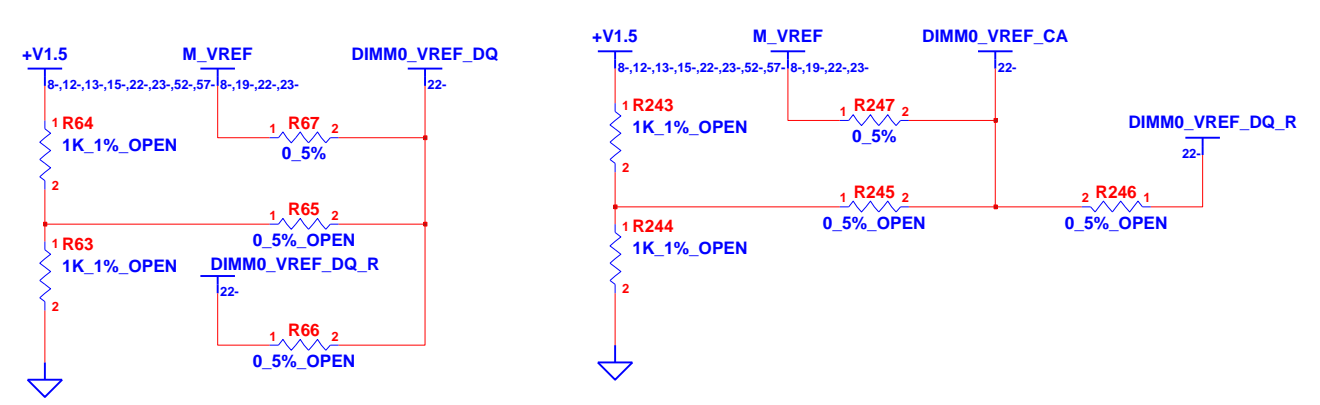
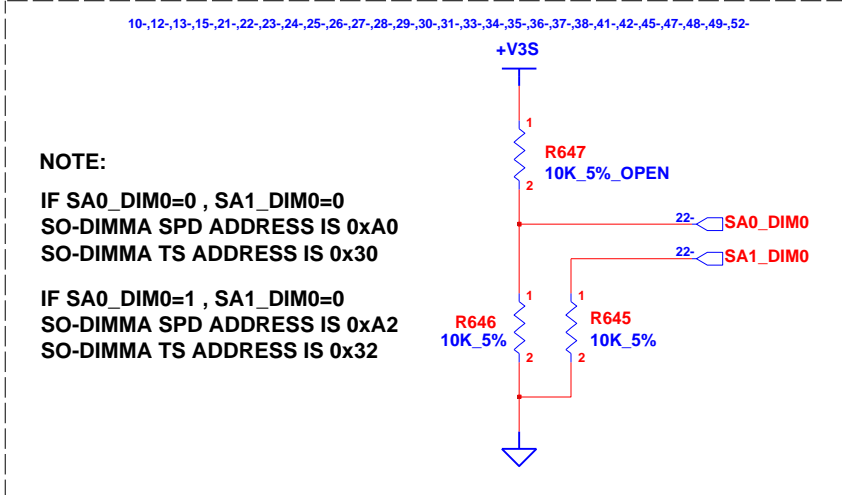
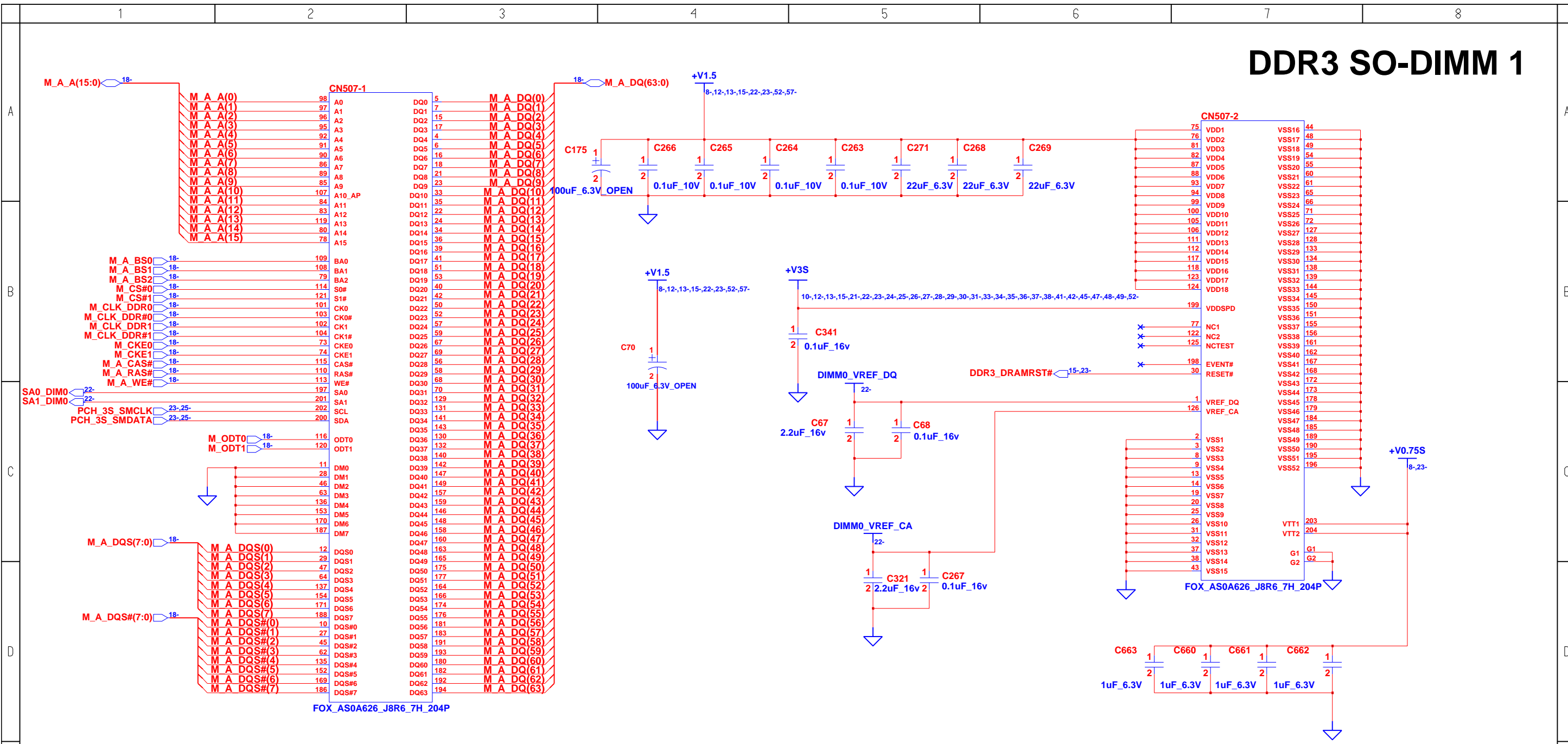

INVENTEC			
TITLE ST133iD			
DDR3-1			
SIZE	CODE	DOC. NUMBER	REV
A3	CS	I310A23179-0-MTR	B
CHANGE by		SHEET	
Chang, Sukigo		22 OF 58	
		21-Jun-2010	

DDR3 SO-DIMM 2

CN1005 (lower) : 6026B0121102
*BOM

Layout Note: Place these Caps near SO-DIMM1 power pin

Place these caps close to VTT1 and VTT2

Place these caps close to VTT1 and VTT2

C666 1uF_6.3V
C665 1uF_6.3V
C664 1uF_6.3V
C667 1uF_6.3V

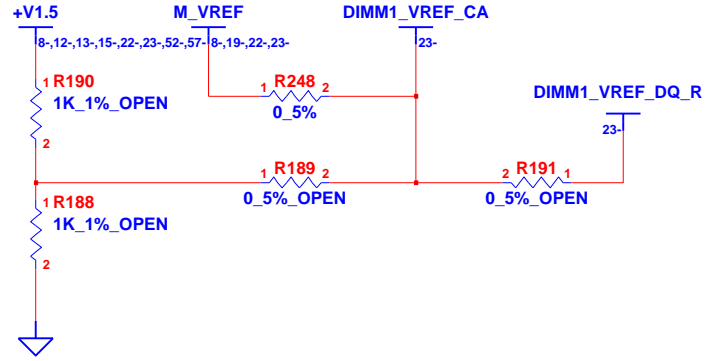
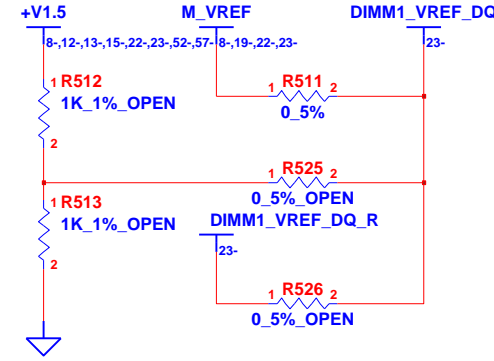
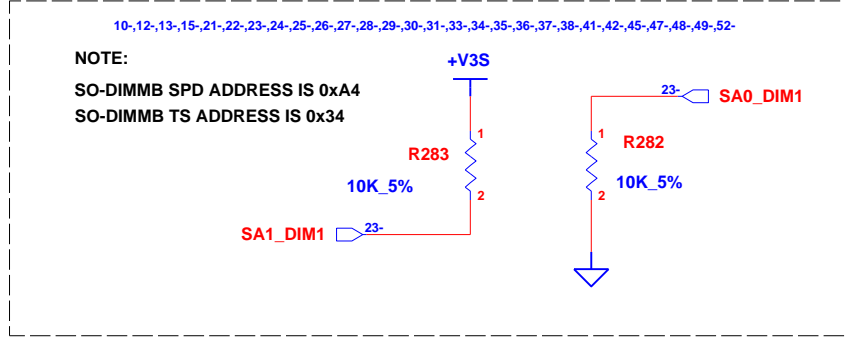
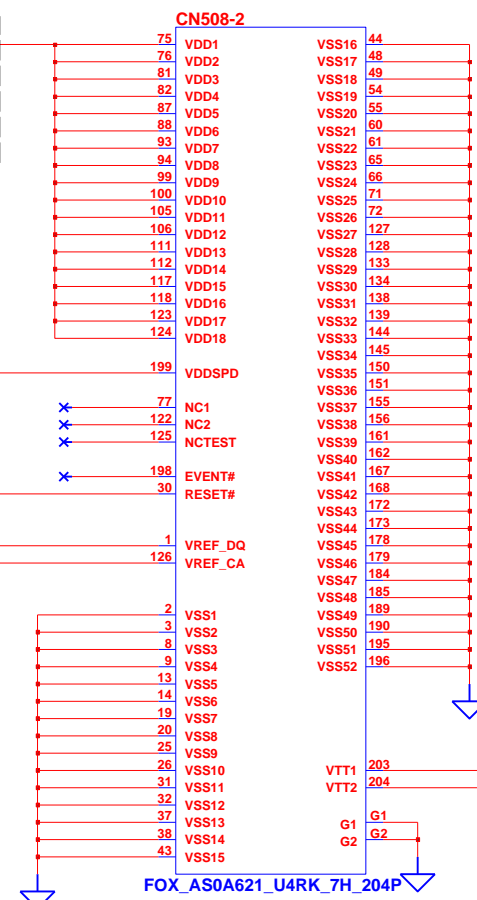
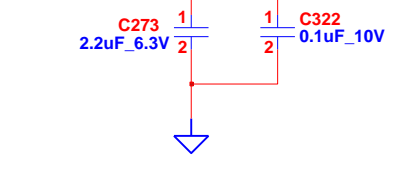
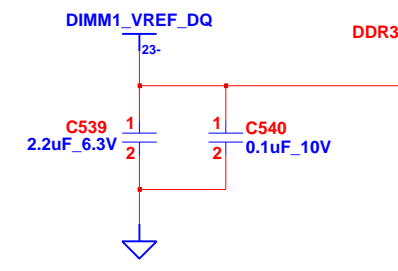
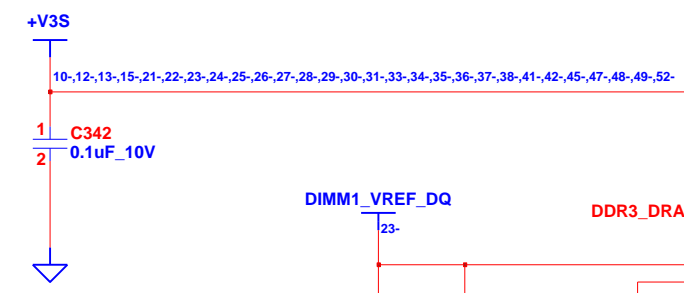
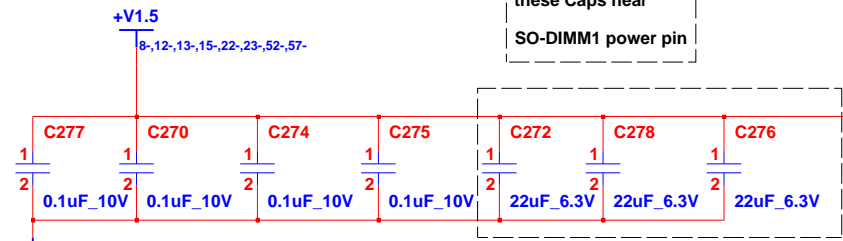
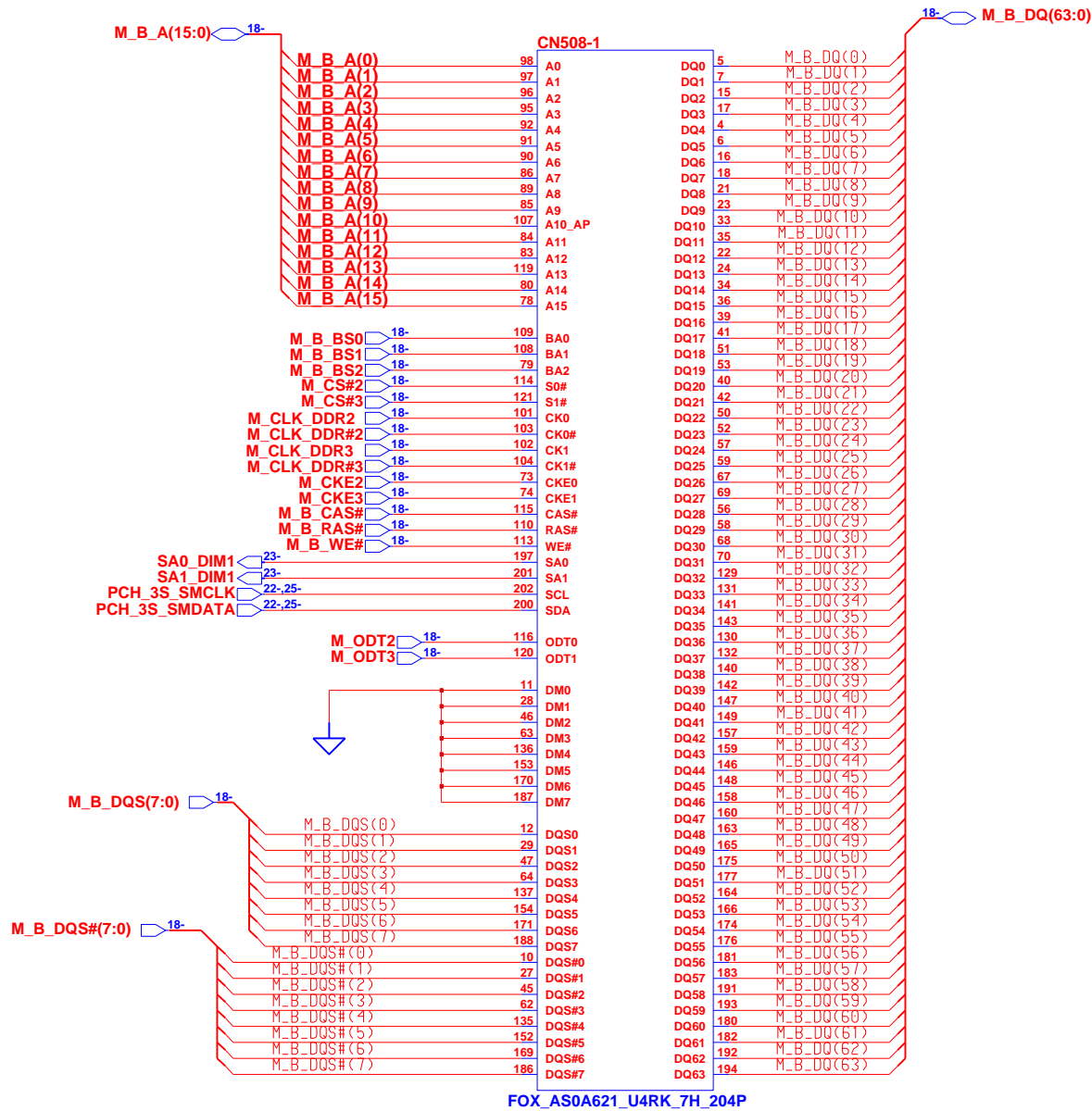

INVENTEC

TITLE			
ST133iD			
DDR3-2			
SIZE	CODE	DOC. NUMBER	REV
A3	CS	1310A23179-0-MTR	B
CHANGE by		SHEET	OF
Chang, Sukigo		23	58

14-Jun-2010

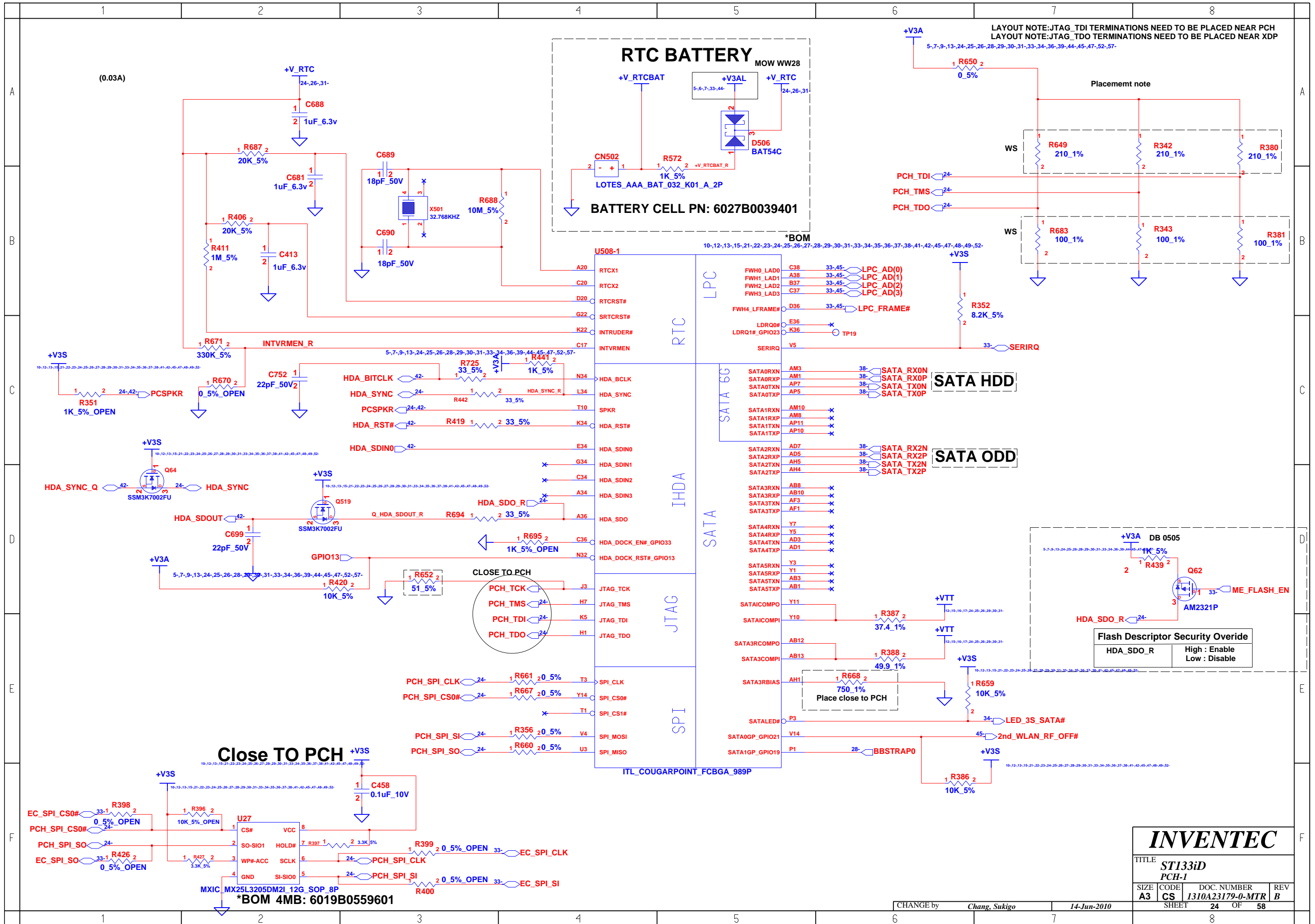

RTC BATTERY
MOW WW28

+V_RTCBAT
+V_RTC

+V3AL
+V_RTC

CN502
LOTES_AAA_BAT_032_K01_A_2P

R572
1K_5%

D506
BAT54C

BATTERY CELL PN: 6027B0039401

LAYOUT NOTE: JTAG_TDI TERMINATIONS NEED TO BE PLACED NEAR PCH
LAYOUT NOTE: JTAG_TDO TERMINATIONS NEED TO BE PLACED NEAR XDP

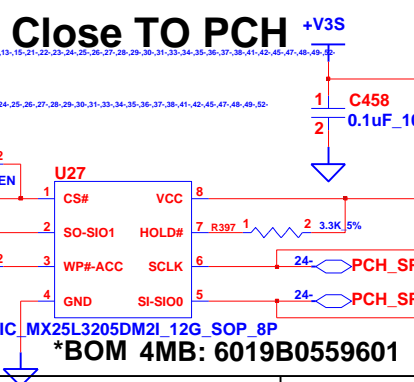
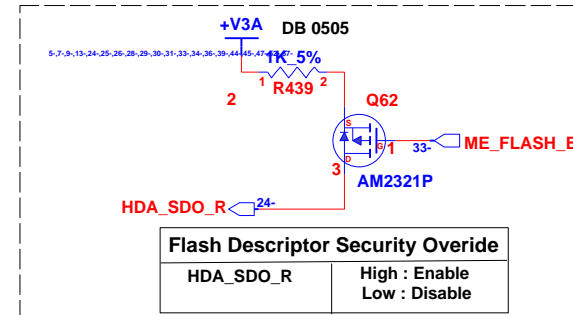
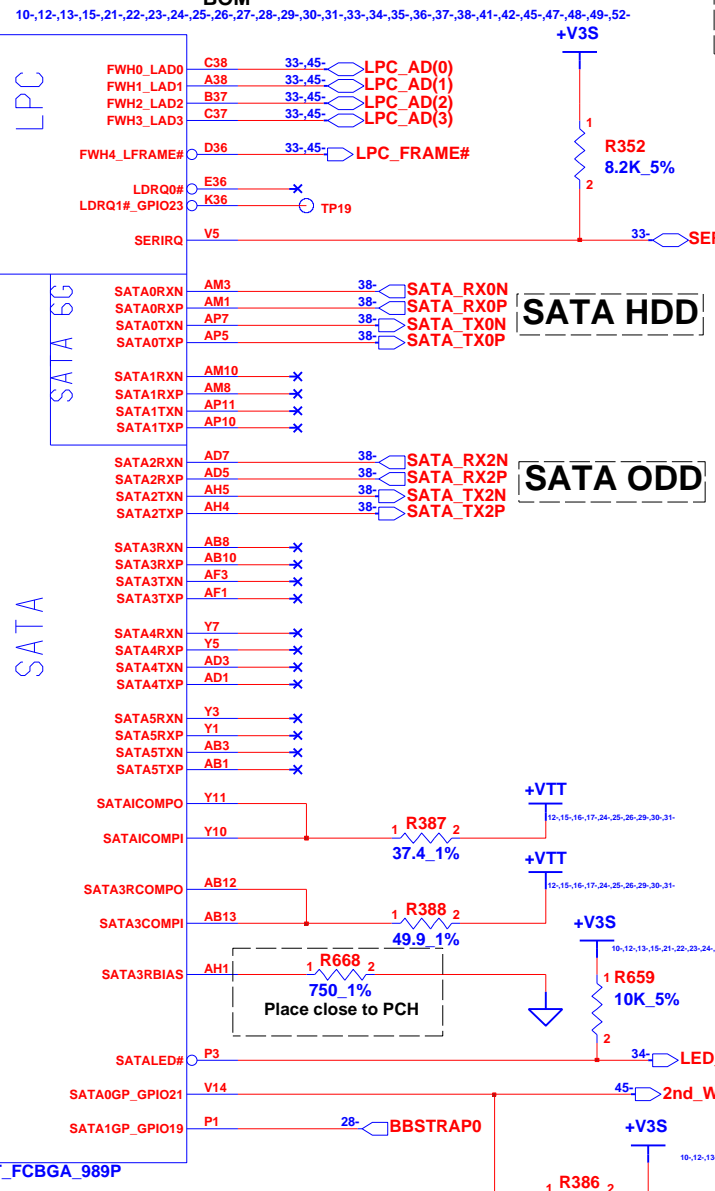
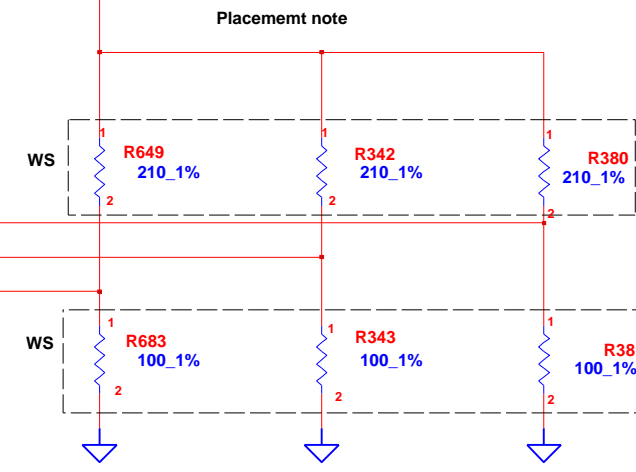

INVENTEC			
TITLE ST133iD			
PCH-1			
SIZE A3	CODE CS	DOC. NUMBER 1310A23179-0-MTR	REV B
CHANGE by Chang, Sukigo		14-Jun-2010	
SHEET 24		OF 58	

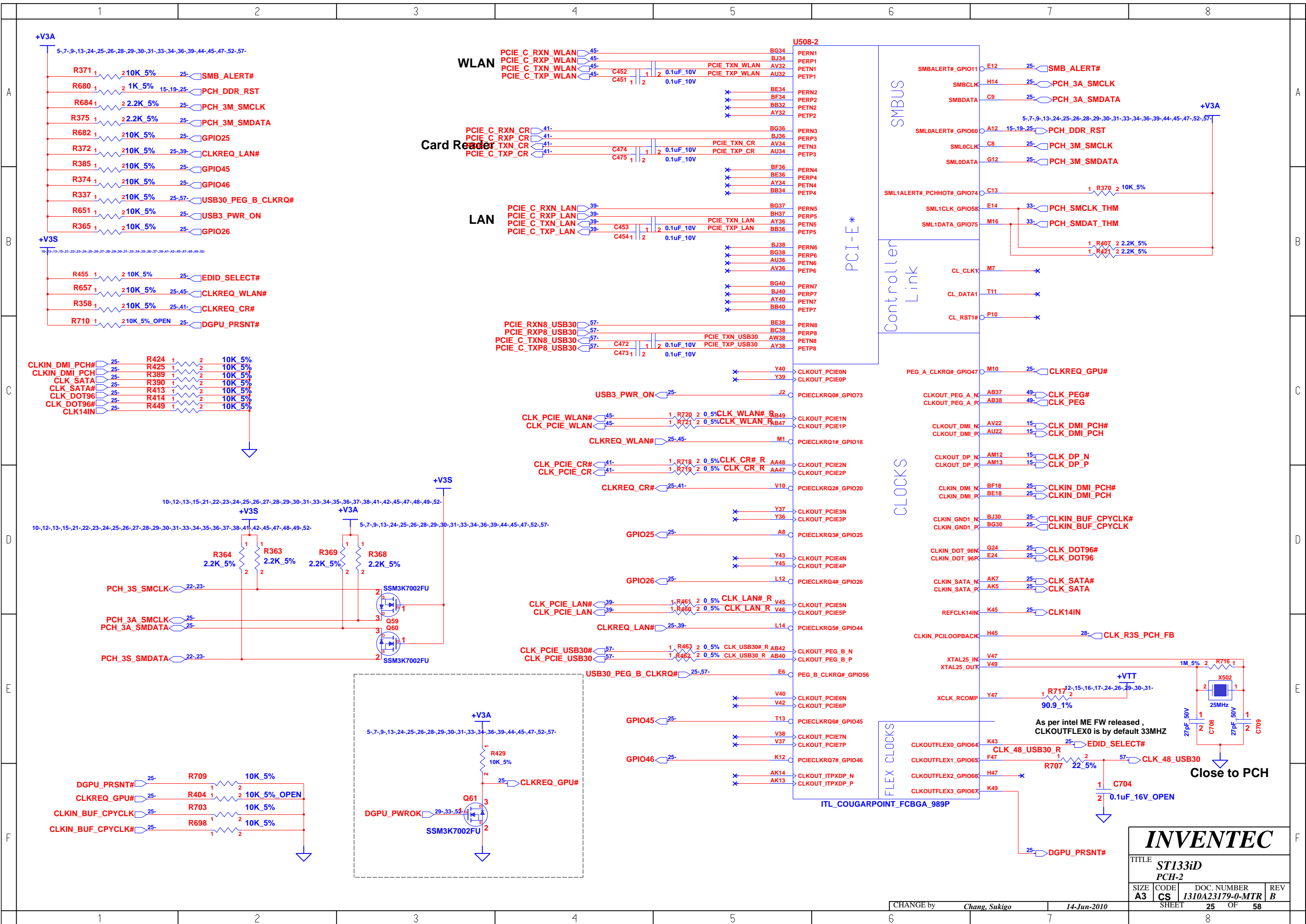

INVENTEC			
TITLE ST133iD PCH-2			
SIZE A3	CODE CS	DOC. NUMBER 1310A23179-0-MTR	REV B
CHANGE by <i>Chang, Sukigo</i>		14-Jun-2010	
SHEET 25		OF 58	

Note: 1.SLP_SUS and SUSACK# are NC if DSW is not supported
 2.DPWROK should connect to RSMRST# if DSW not supported
 3.PCH_DPWROK pull up to +V3S enables DSW wupport. No install R5261 to disable DSW

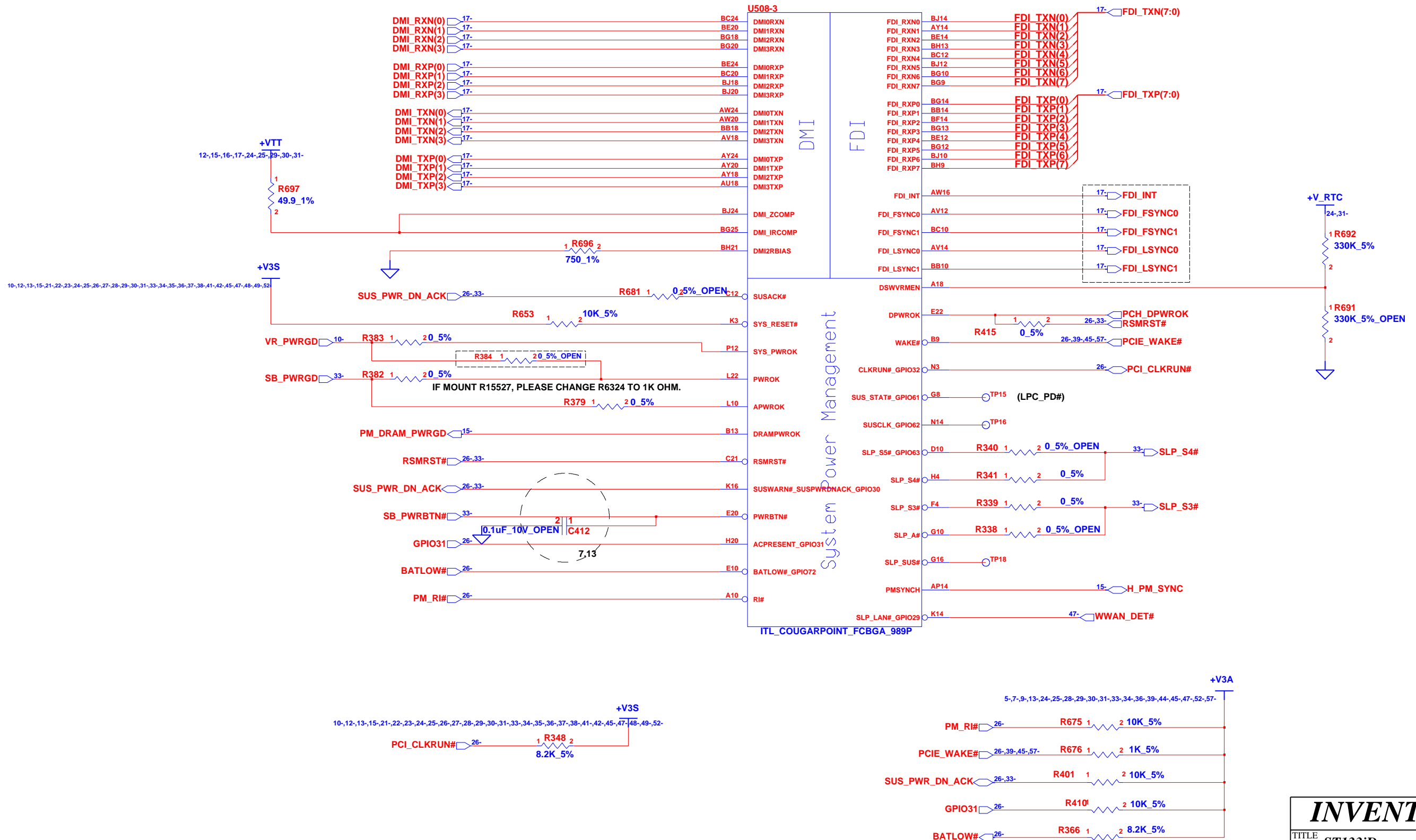

INVENTEC			
TITLE ST133iD			
PCH-3			
SIZE A3	CODE CS	DOC. NUMBER 1310A23179-0-MTR	REV B
CHANGE by Chang, Sukigo		14-Jun-2010	
SHEET 26		OF 58	

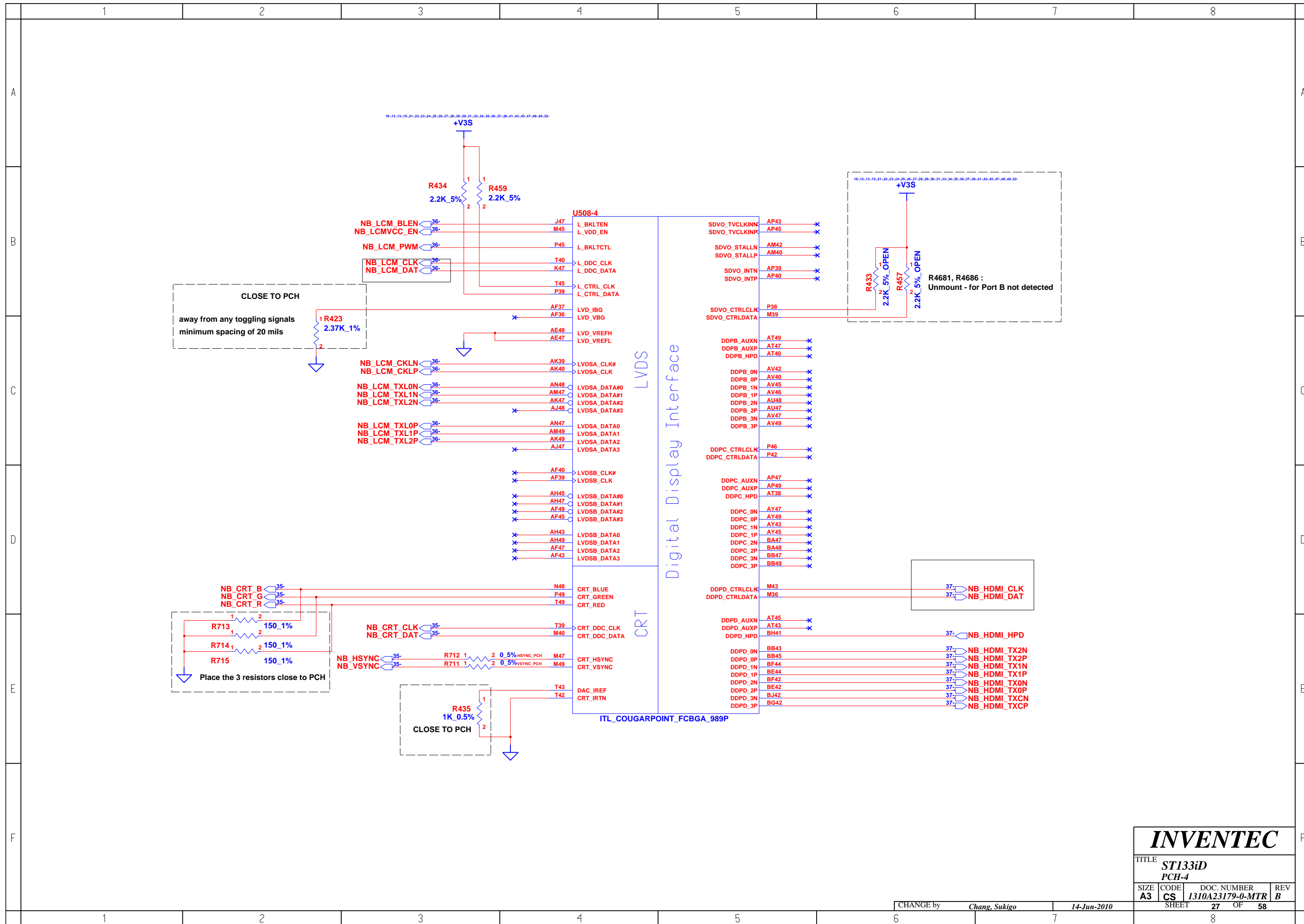

INVENTEC			
TITLE ST133iD			
PCH-4			
SIZE	CODE	DOC. NUMBER	REV
A3	CS	1310A23179-0-MTR	B
CHANGE by		14-Jun-2010	
SHEET		27	OF 58

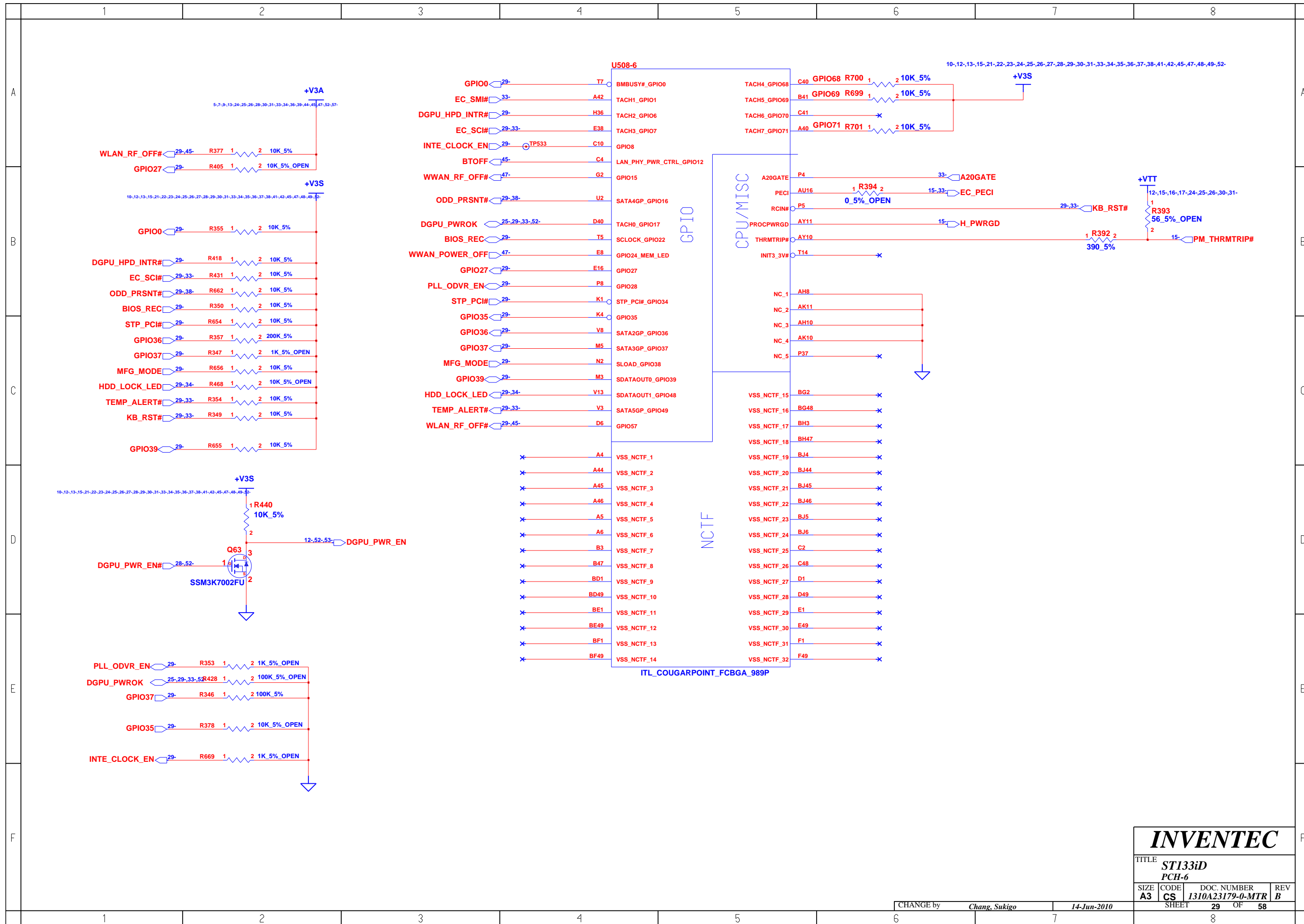

INVENTEC

TITLE **ST133iD PCH-6**

SIZE A3	CODE CS	DOC. NUMBER 1310A23179-0-MTR	REV B
CHANGE by Chang, Sukigo		14-Jun-2010	
SHEET 29		OF 58	

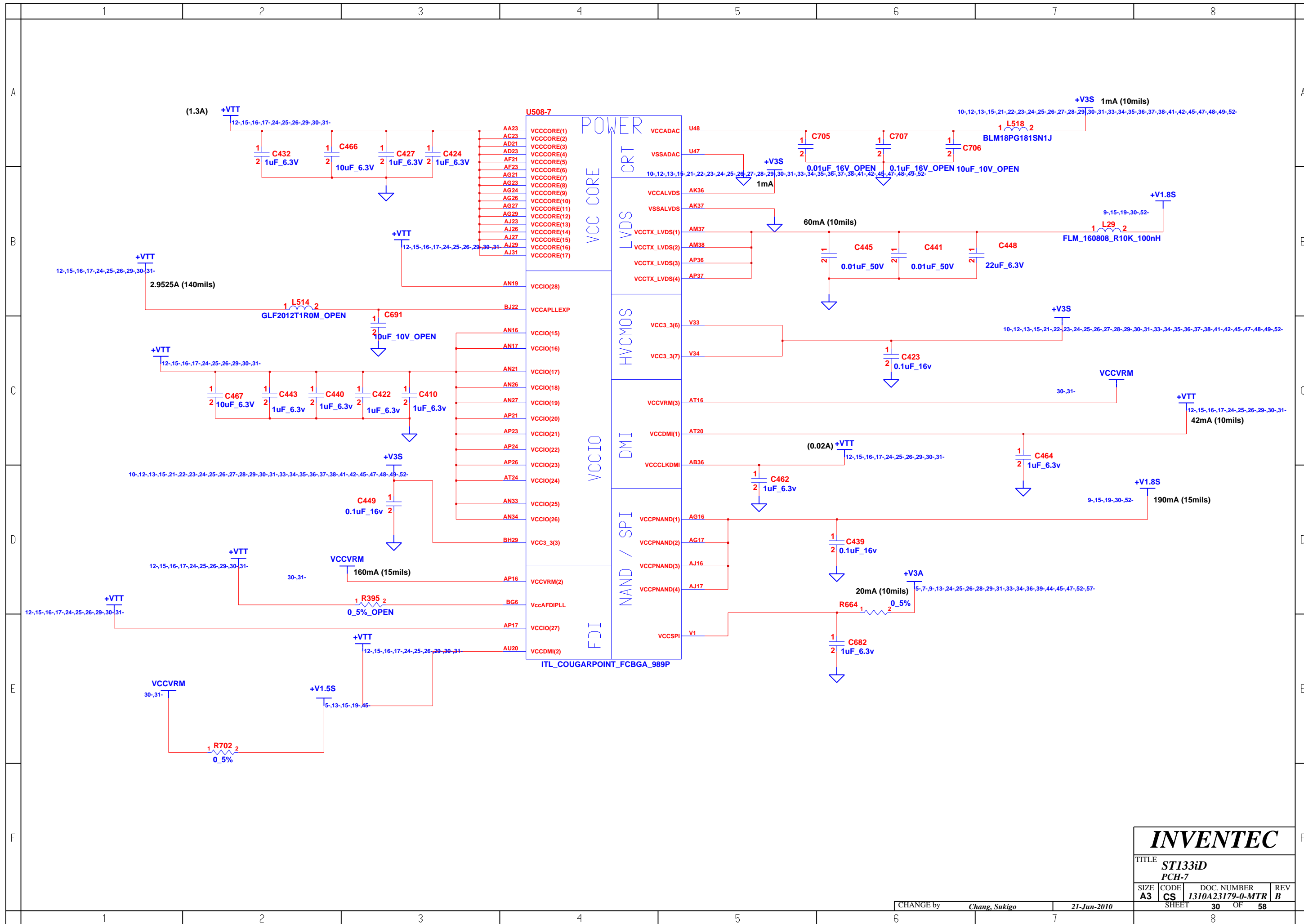

INVENTEC			
TITLE ST133iD			
PCH-7			
SIZE A3	CODE CS	DOC. NUMBER 1310A23179-0-MTR	REV B
CHANGE by <i>Chang, Sukigo</i>		21-Jun-2010	
SHEET 30		OF 58	

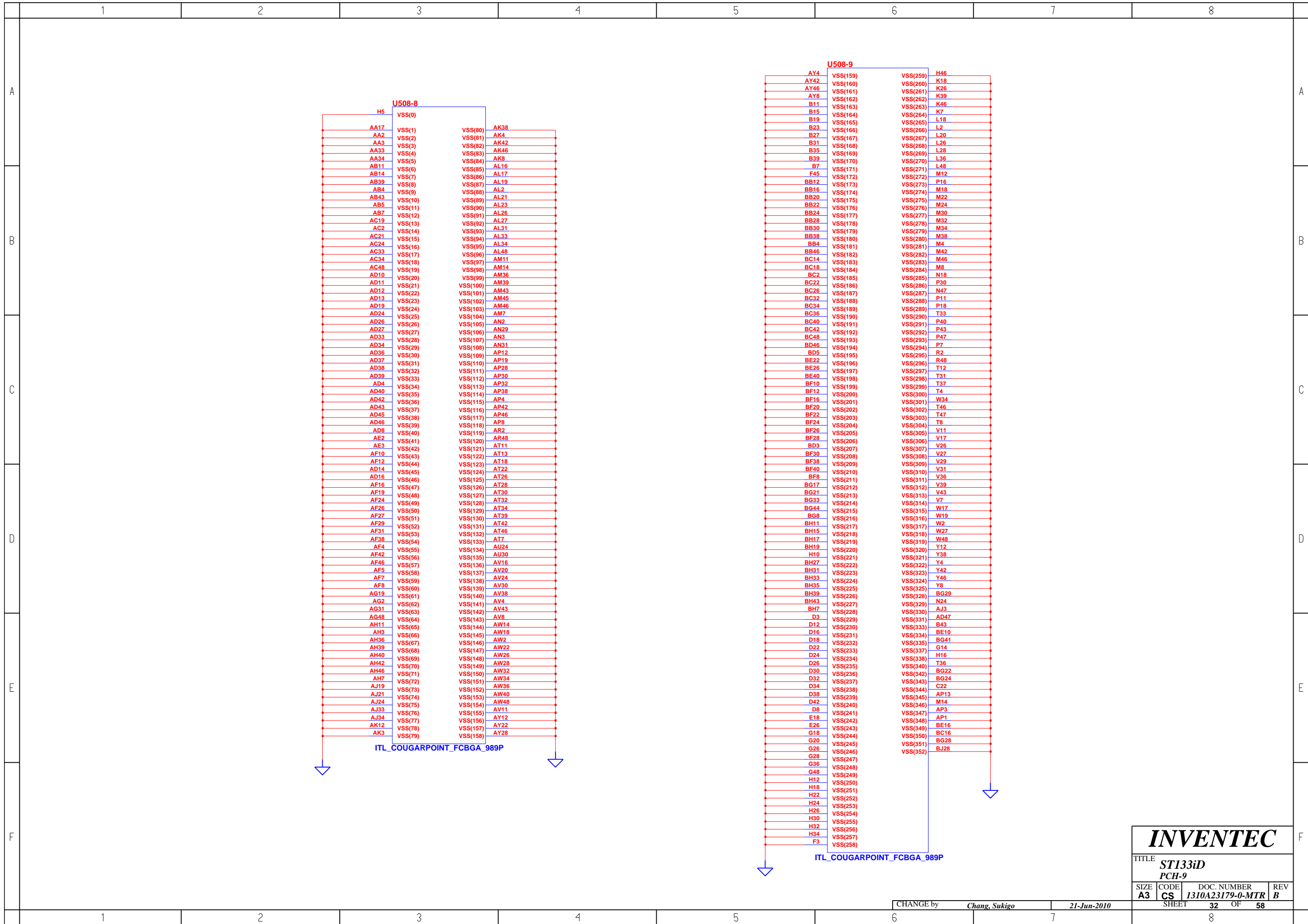

INVENTEC

TITLE *ST133iD*
PCH-9

SIZE	CODE	DOC. NUMBER	REV
A3	CS	1310A23179-0-MTR	B

SHEET 32 OF 58

CHANGE by *Chang, Sukigo* 21-Jun-2010

KeyBoard CONN (30 pin)

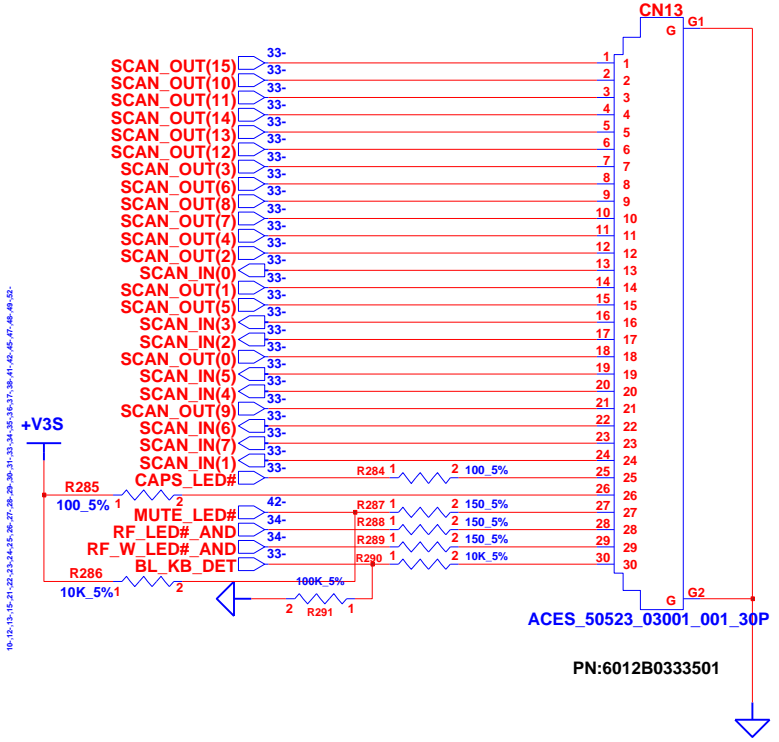

TouchPad Module CONN

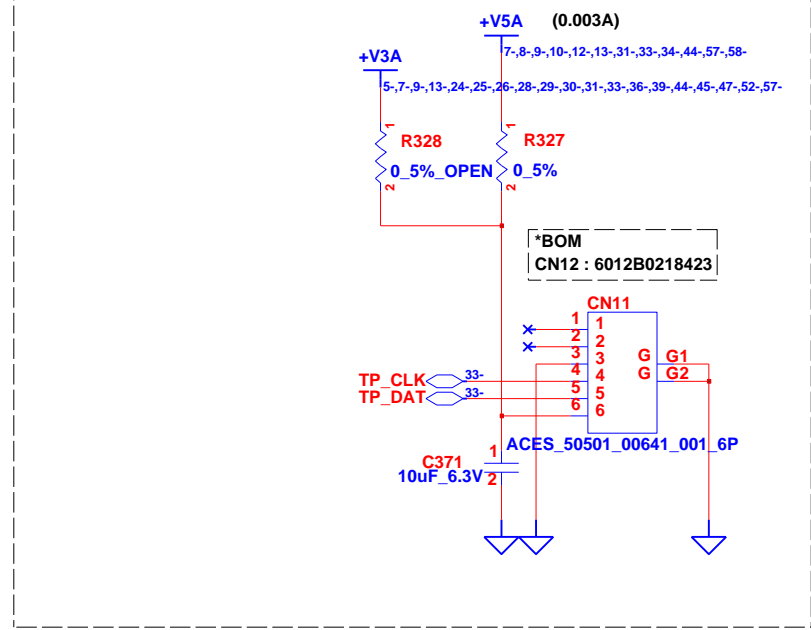

DC-JACK LED

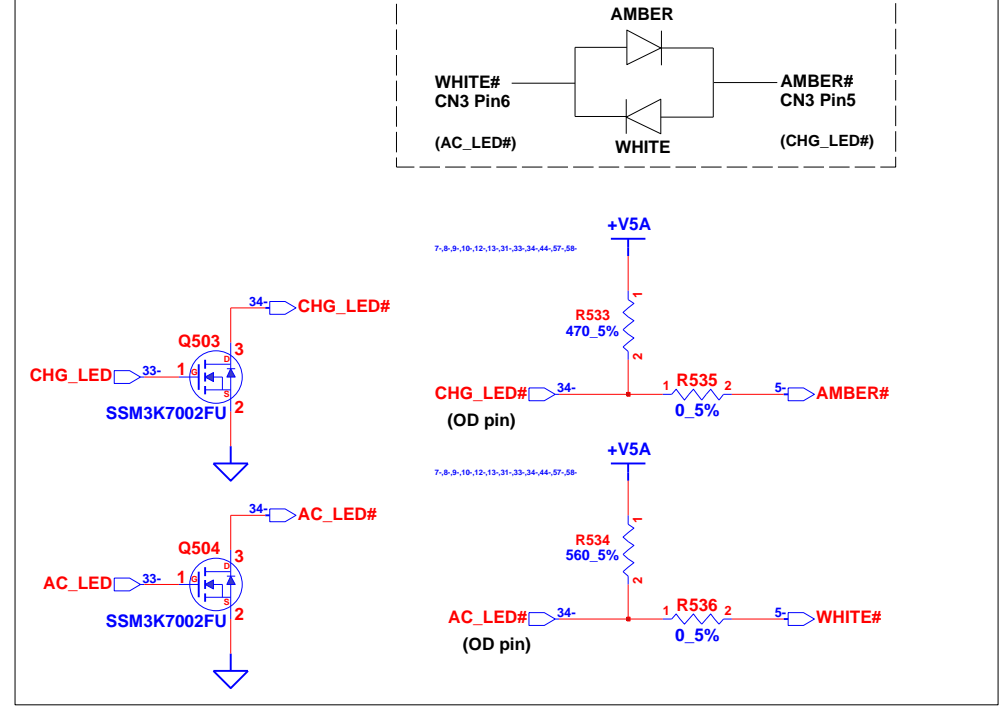

SATA LED & HDD-HALTED LED

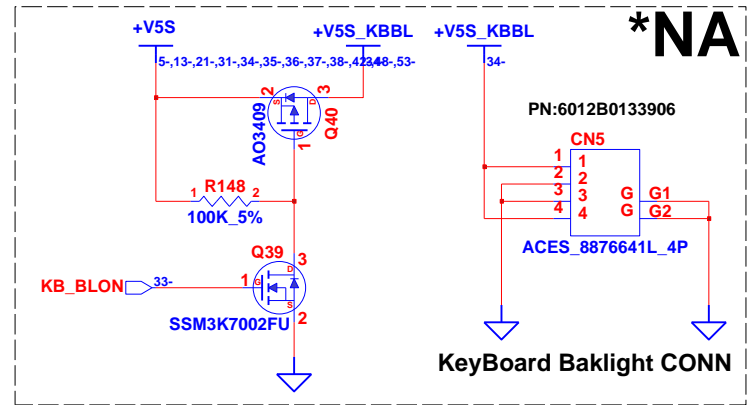
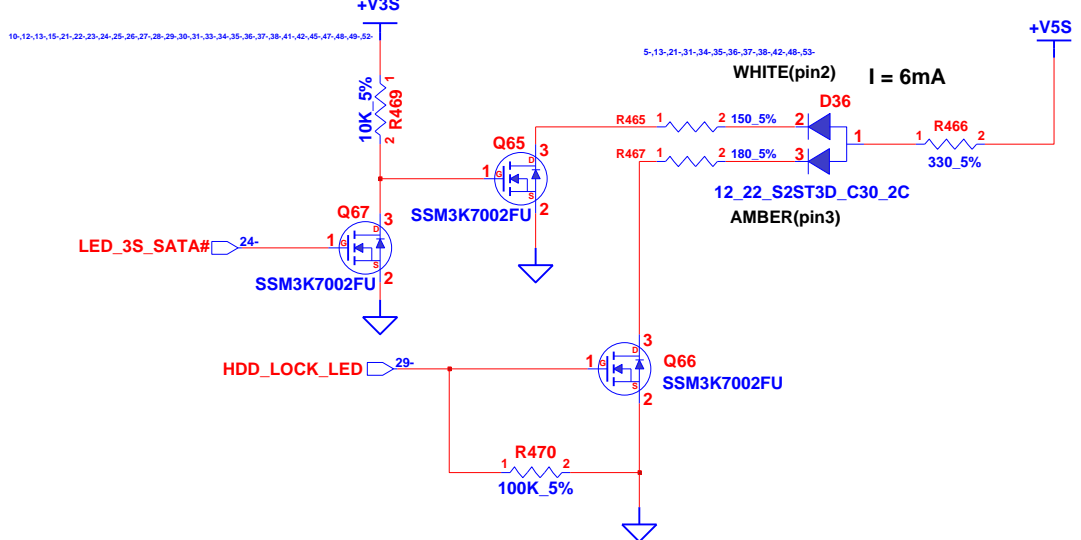

POWER LED

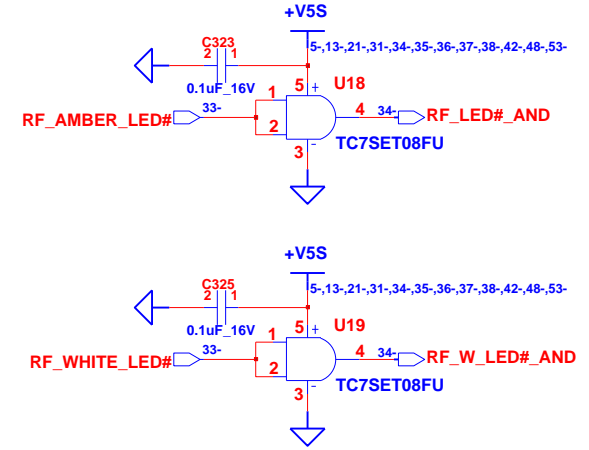
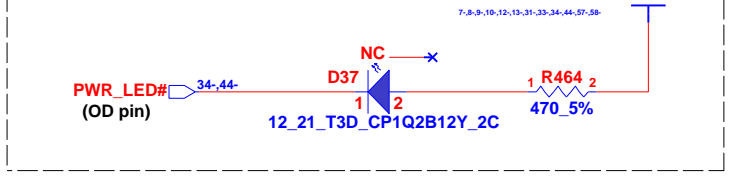

INVENTEC

TITLE			
ST133iD			
Keyboard & TouchPad			
SIZE	CODE	DOC. NUMBER	REV
A3	CS	I310A23179-0-MTR	B
CHANGE by		SHEET	
Chang, Sukigo		34 OF 58	

14-Jun-2010

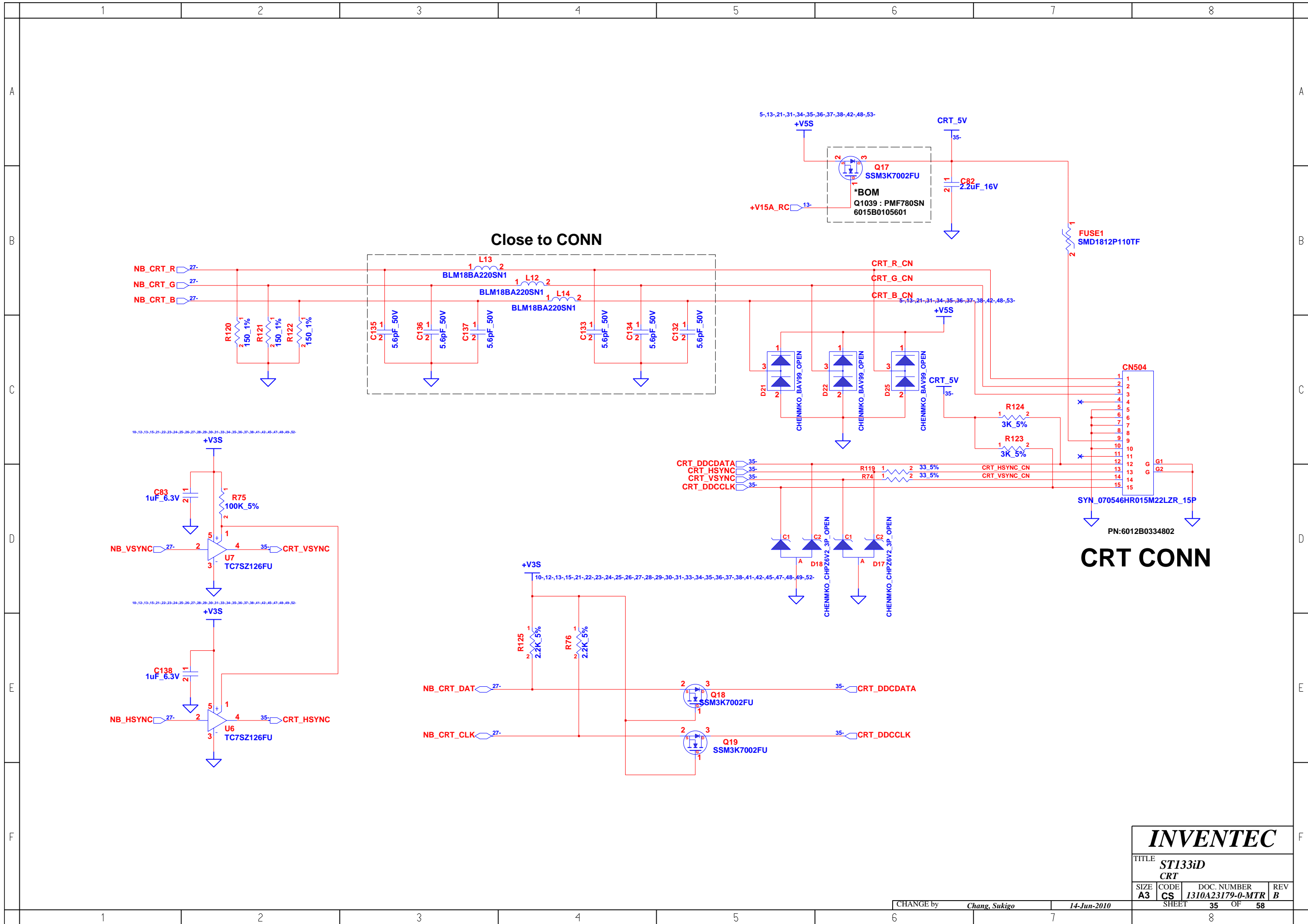

INVENTEC

TITLE			
ST133iD CRT			
SIZE	CODE	DOC. NUMBER	REV
A3	CS	1310A23179-0-MTR	B
SHEET		35	OF 58

CHANGE by Chang, Sukigo 14-Jun-2010

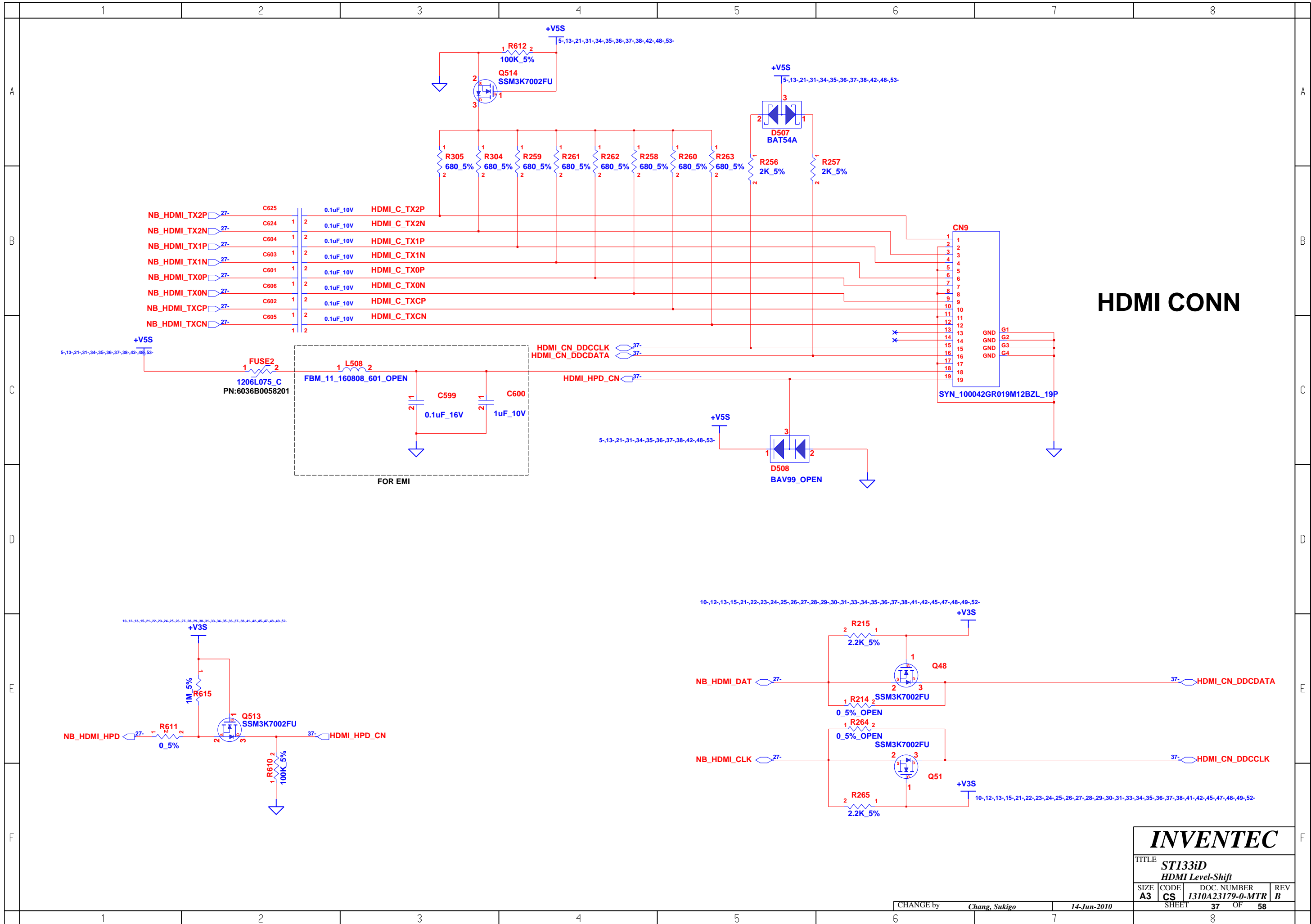

HDMI CONN

INVENTEC

TITLE			
ST133iD			
HDMI Level-Shift			
SIZE	CODE	DOC. NUMBER	REV
A3	CS	1310A23179-0-MTR	B
SHEET		OF	58
37			

CHANGE by *Chang, Sukigo* 14-Jun-2010

A

B

C

D

E

F

A

B

C

D

E

F

SATA HDD FPC CONN on MB

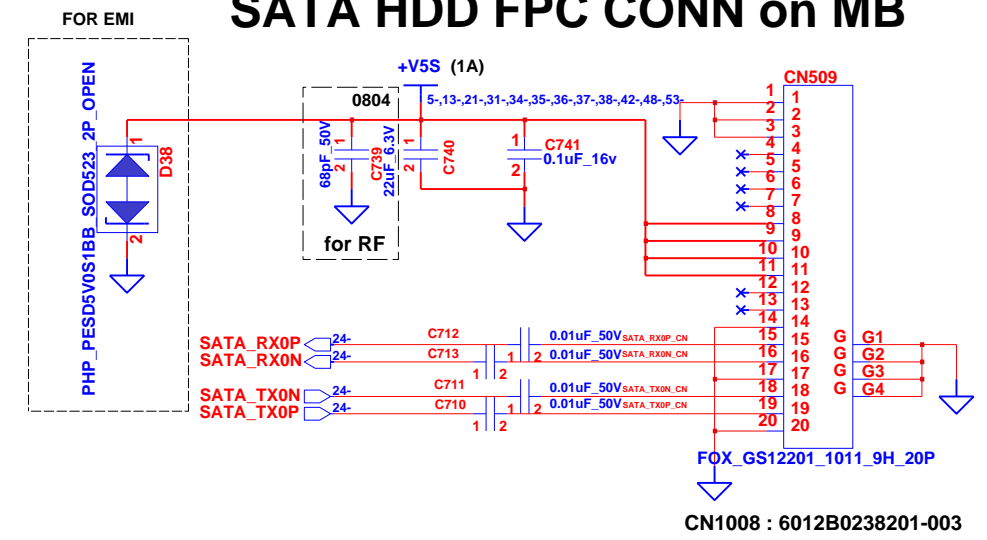

SATA ODD FPC CONN on MB

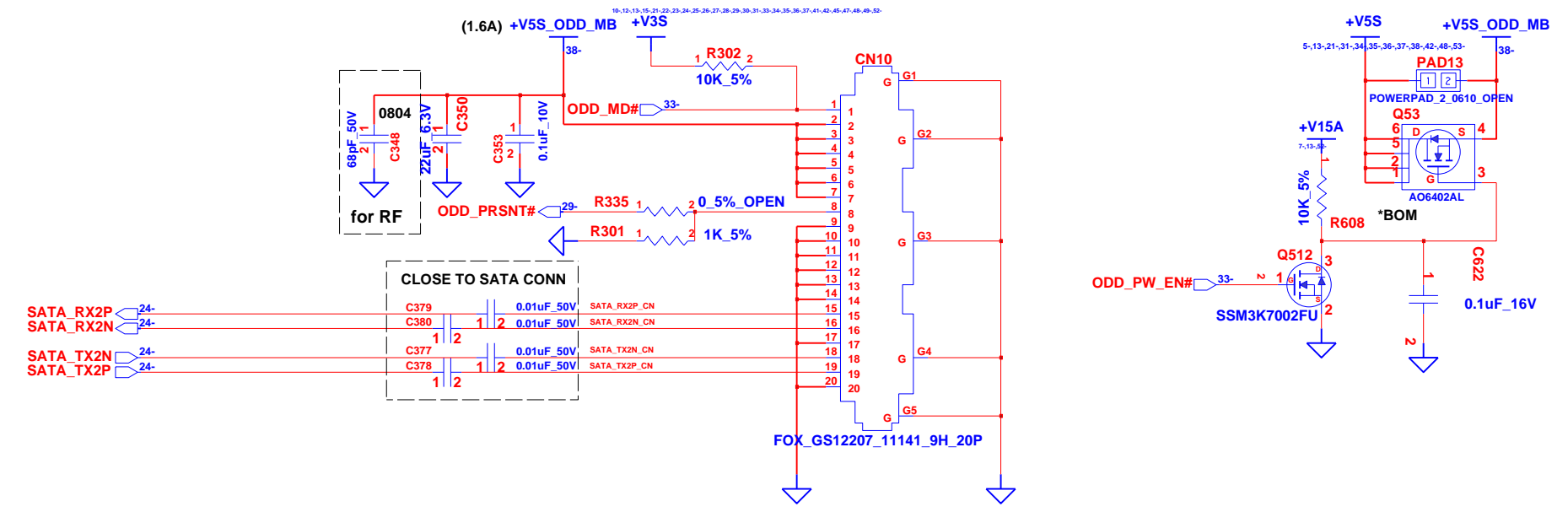

INVENTEC

TITLE			
ST133iD			
SATA HDD & ODD			
SIZE	CODE	DOC. NUMBER	REV
A3	CS	1310A23179-0-MTR	B
CHANGE by		SHEET	
Chang, Sukigo		38 OF 58	

14-Jun-2010

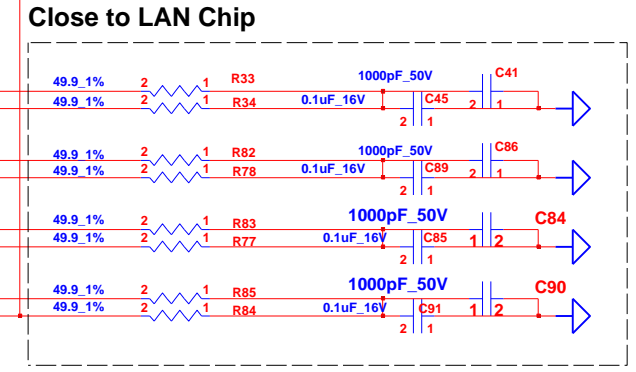
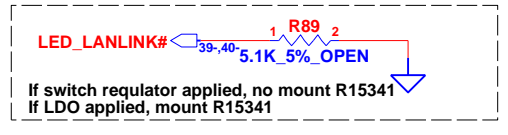
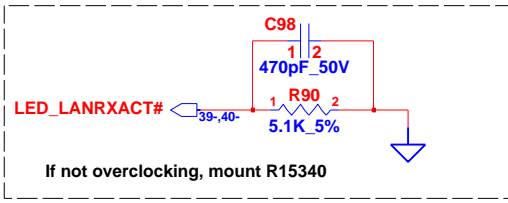
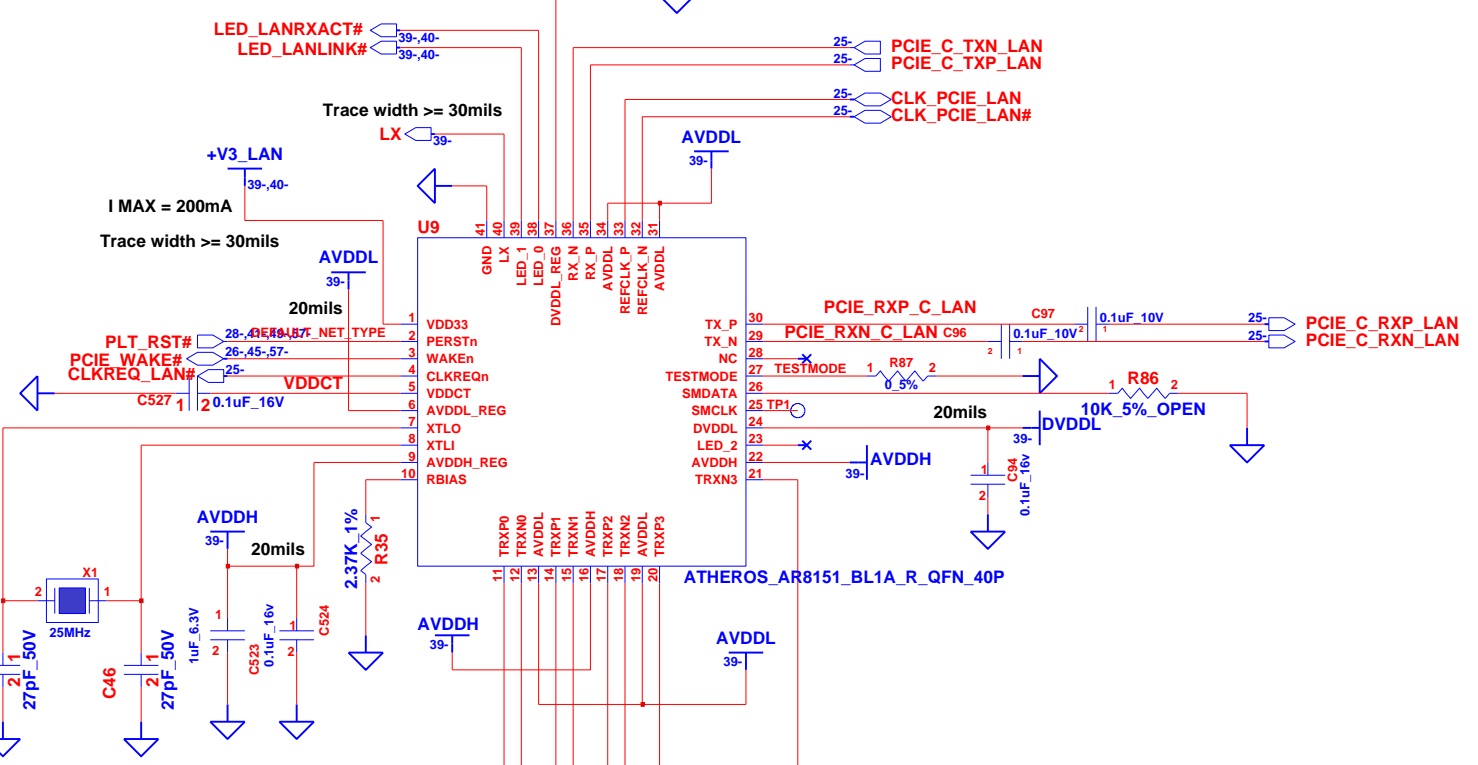
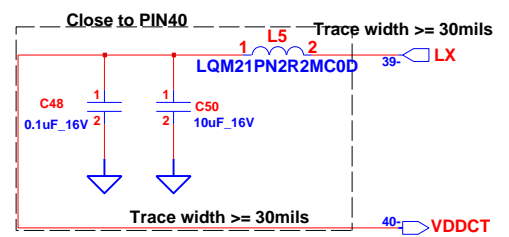
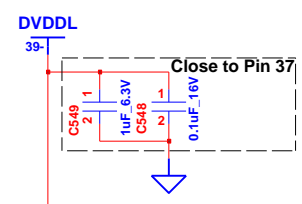
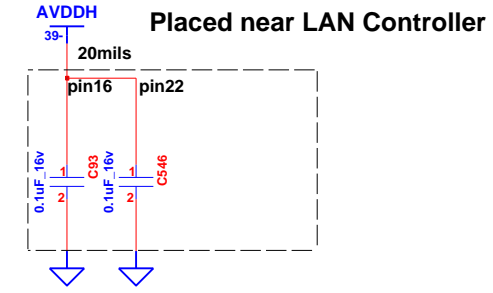
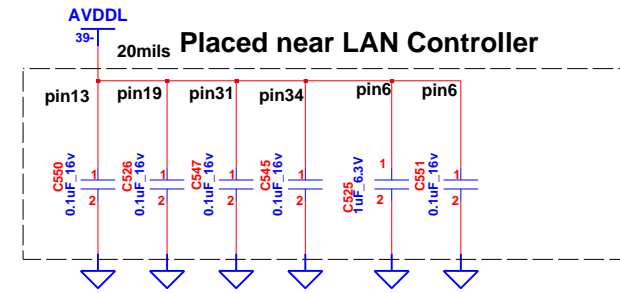
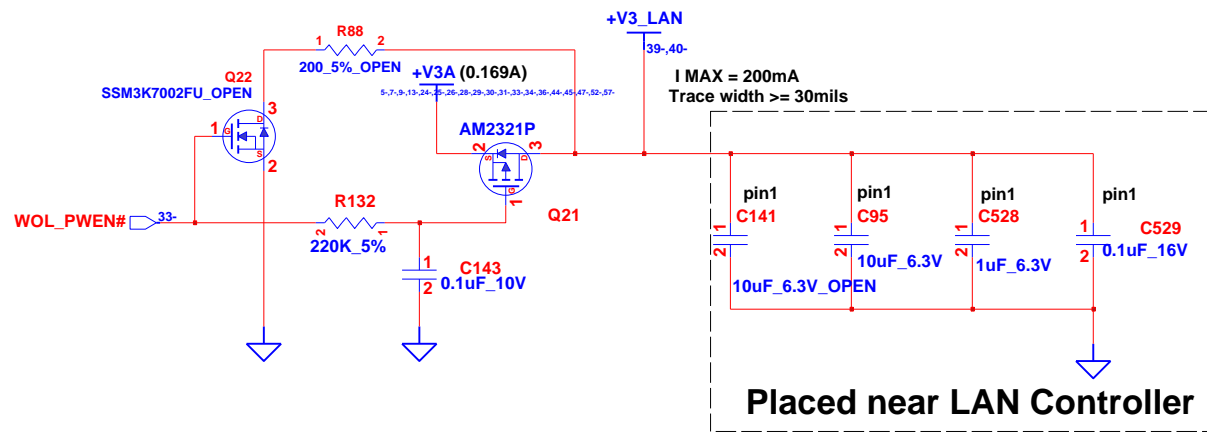

25MHz : 6018A0011301
HEIGHT : 1.3mm
for Reference

INVENTEC

TITLE			
ST133iD			
LAN			
SIZE	CODE	DOC. NUMBER	REV
A3	CS	1310A23179-0-MTR	B
SHEET		39	OF 58

CHANGE by Chang, Sukigo 14-Jun-2010

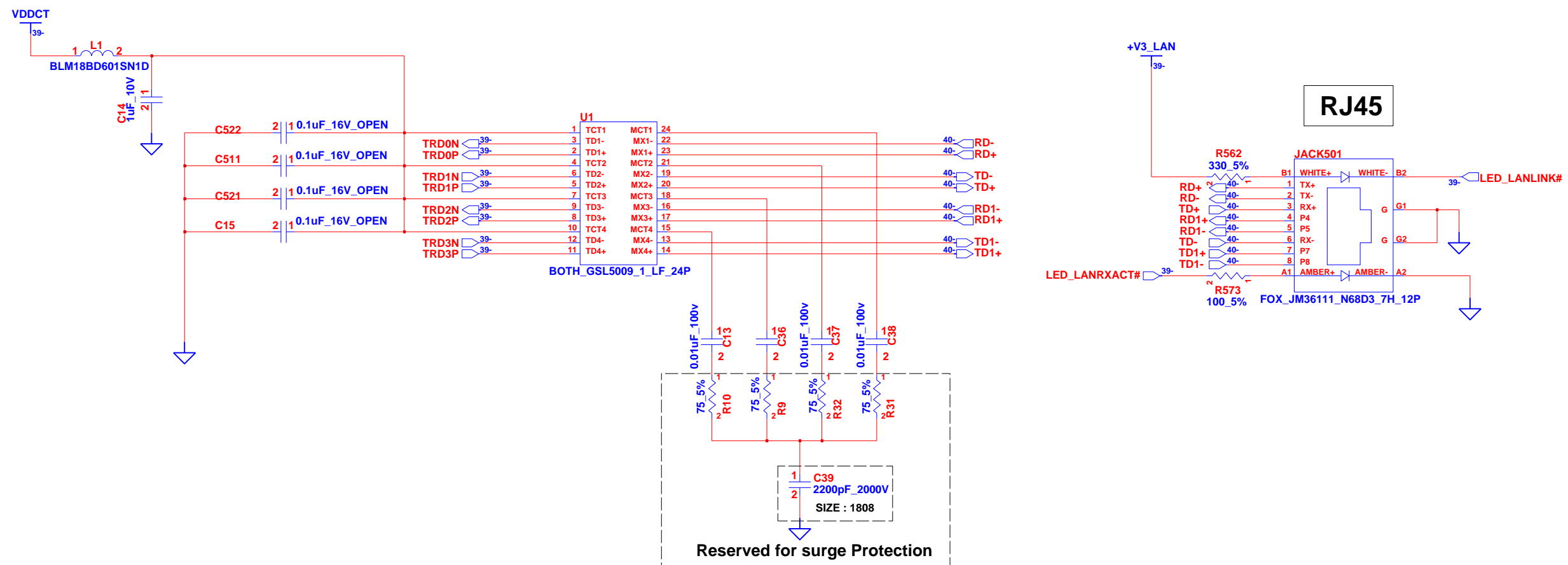

LAYOUT NOTE : Place termination resistors and caps as close to LAN controller as possible

INVENTEC			
TITLE ST133iD			
RJ-45			
SIZE A3	CODE CS	DOC. NUMBER 1310A23179-0-MTR	REV B
CHANGE by <i>Chang, Sukigo</i>		14-Jun-2010	
SHEET 40		OF 58	

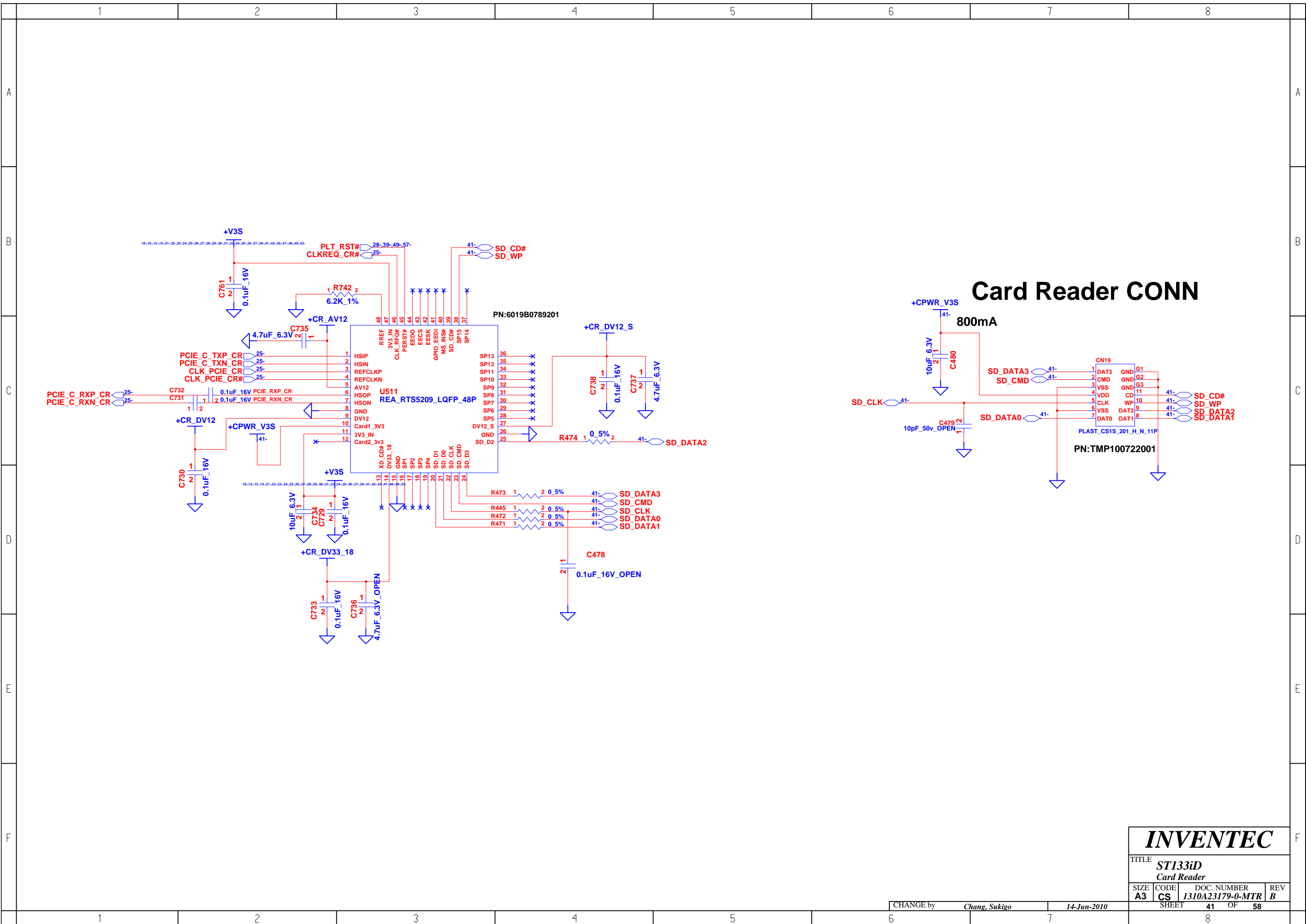

Card Reader CONN

INVENTEC			
TITLE ST133iD Card Reader			
SIZE A3	CODE CS	DOC. NUMBER 1310A23179-0-MTR	REV B
CHANGE by Chang, Sukigo		14-Jun-2010	
SHEET 41		OF 58	

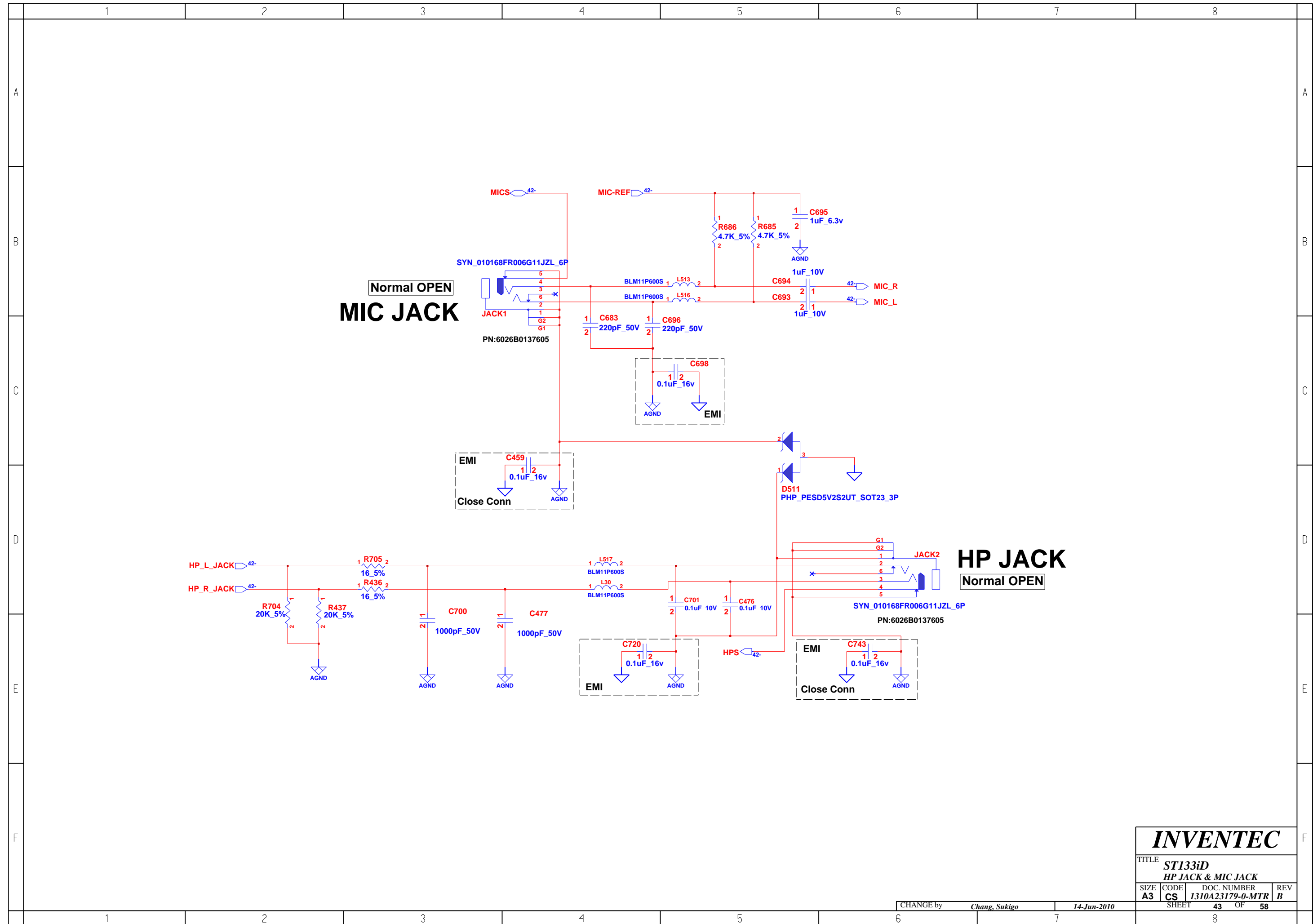

Normal OPEN
MIC JACK

HP JACK
Normal OPEN

INVENTEC

TITLE			
ST133iD			
HP JACK & MIC JACK			
SIZE	CODE	DOC. NUMBER	REV
A3	CS	I310A23179-0-MTR	B
SHEET		43	OF 58

CHANGE by *Chang, Sukigo* 14-Jun-2010

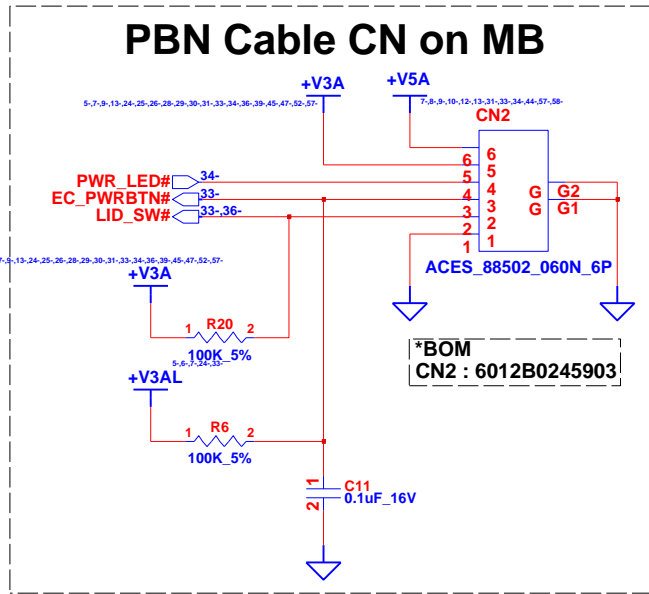
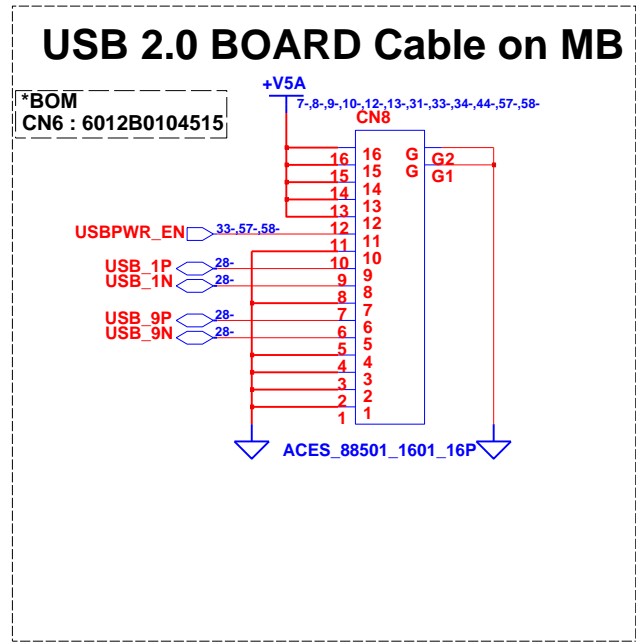
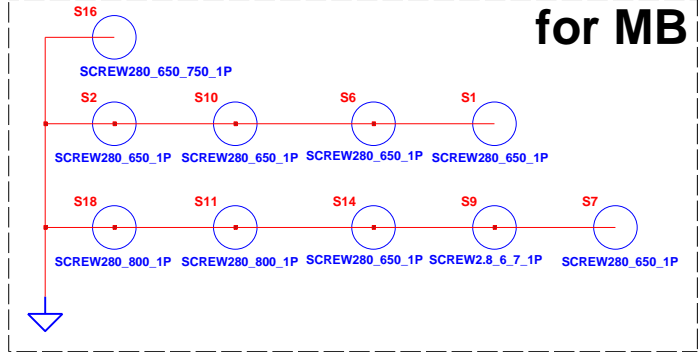
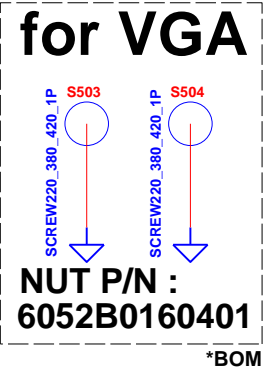
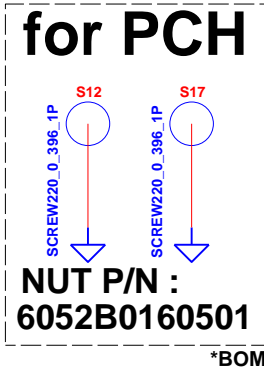
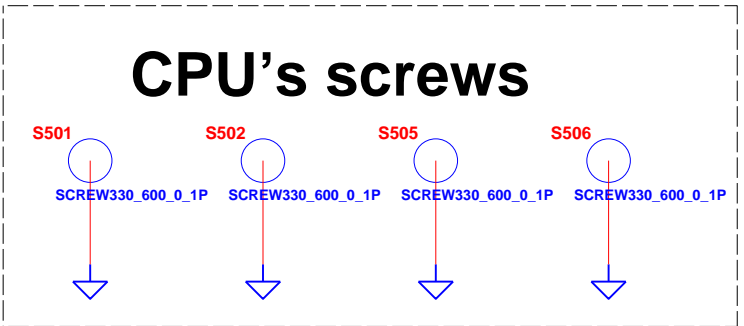
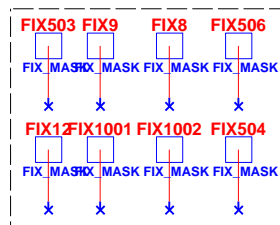

INVENTEC

TITLE			
ST133iD			
ESATA, SCREW & LID			
SIZE	CODE	DOC. NUMBER	REV
A3	CS	1310A23179-0-MTR	B
SHEET		44	OF 58

CHANGE by *Chang, Sukigo* 14-Jun-2010

USB BOARD

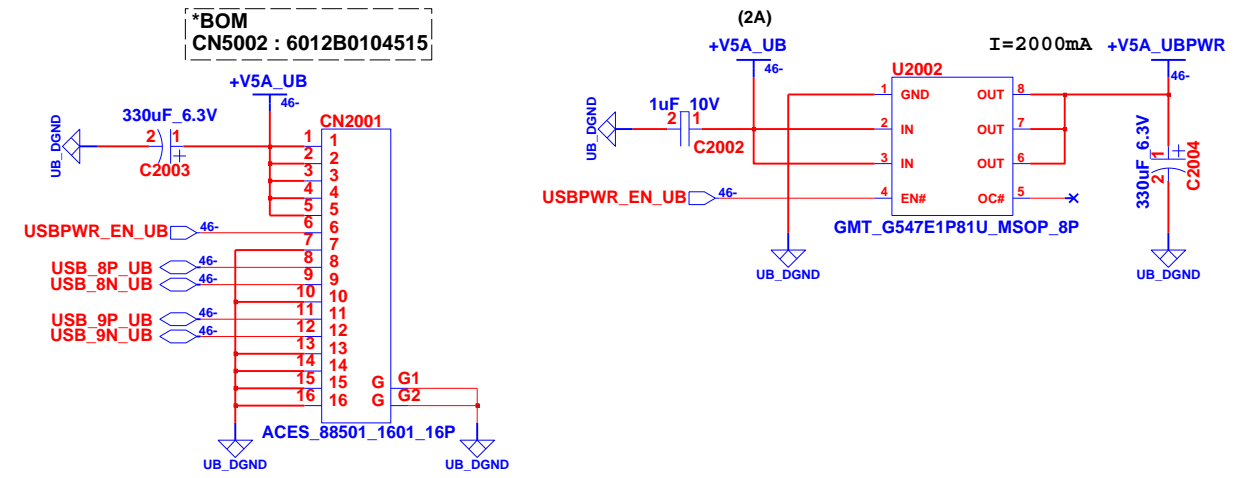

USB CONN01

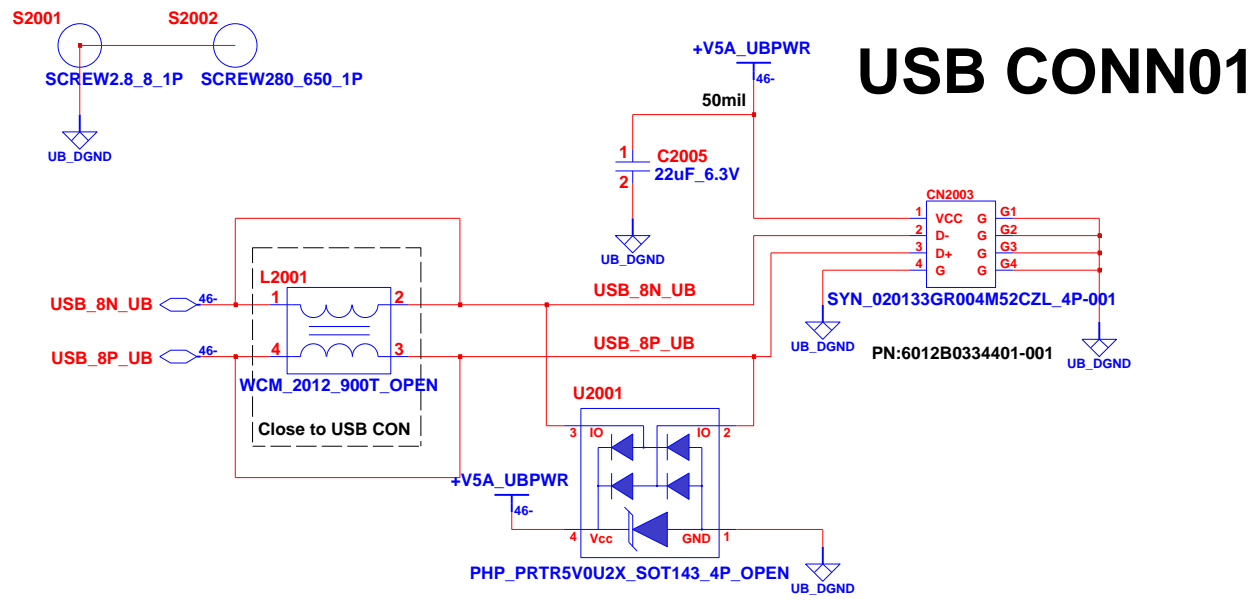

USB CONN02

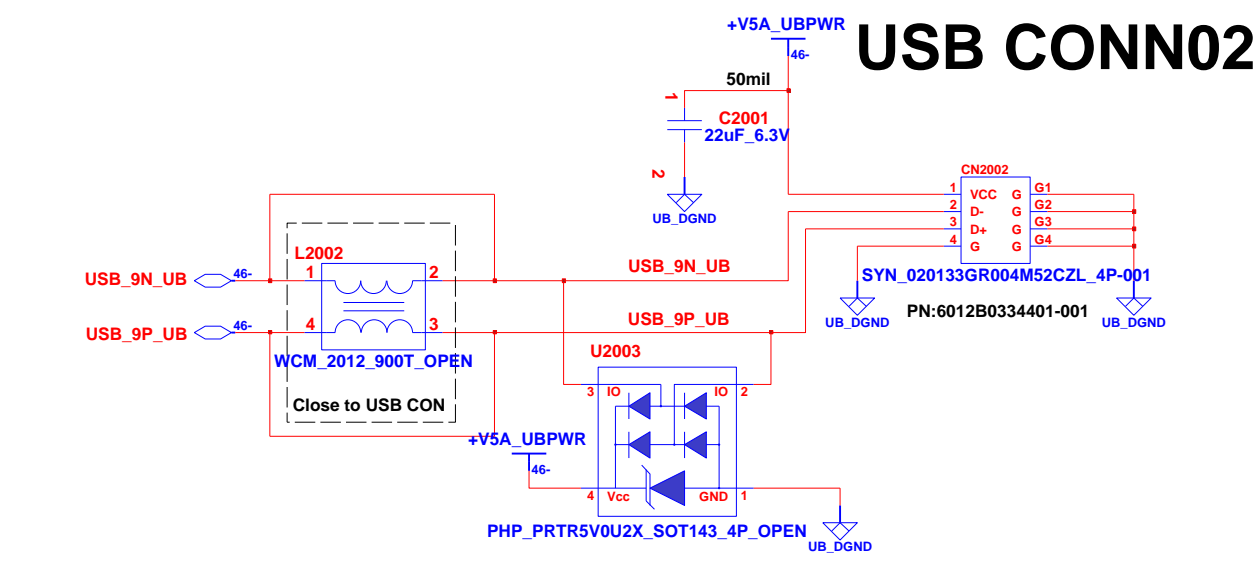

Power Button Board

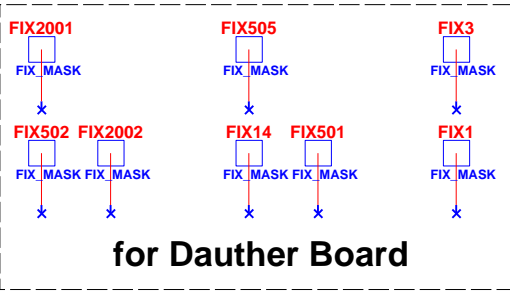
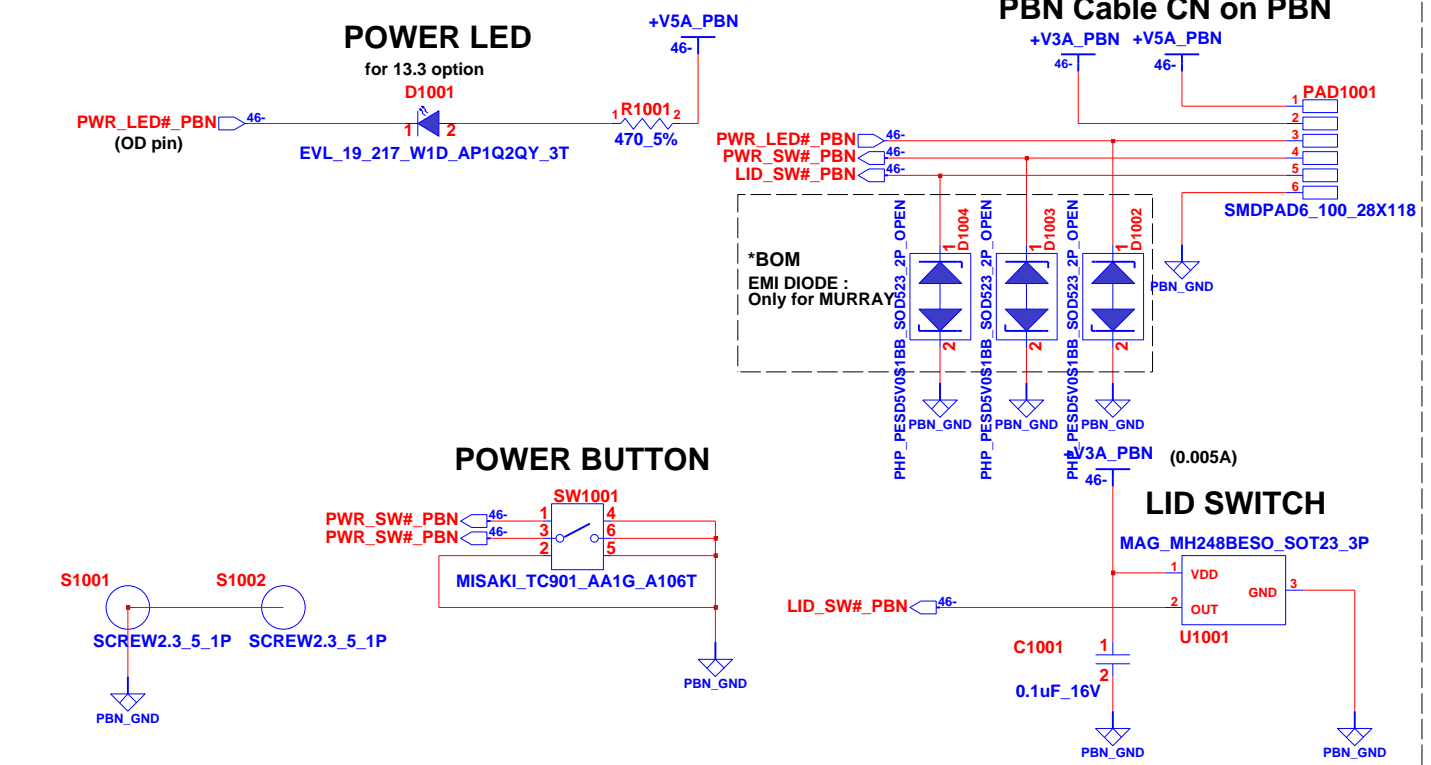

INVENTEC

TITLE			
ST133iD			
USB, PowerButton (DB)			
SIZE	CODE	DOC. NUMBER	REV
A3	CS	1310A23179-0-MTR	B
CHANGE by		SHEET	
Chang, Sukigo		46 OF 58	

14-Jun-2010

OPTION PART

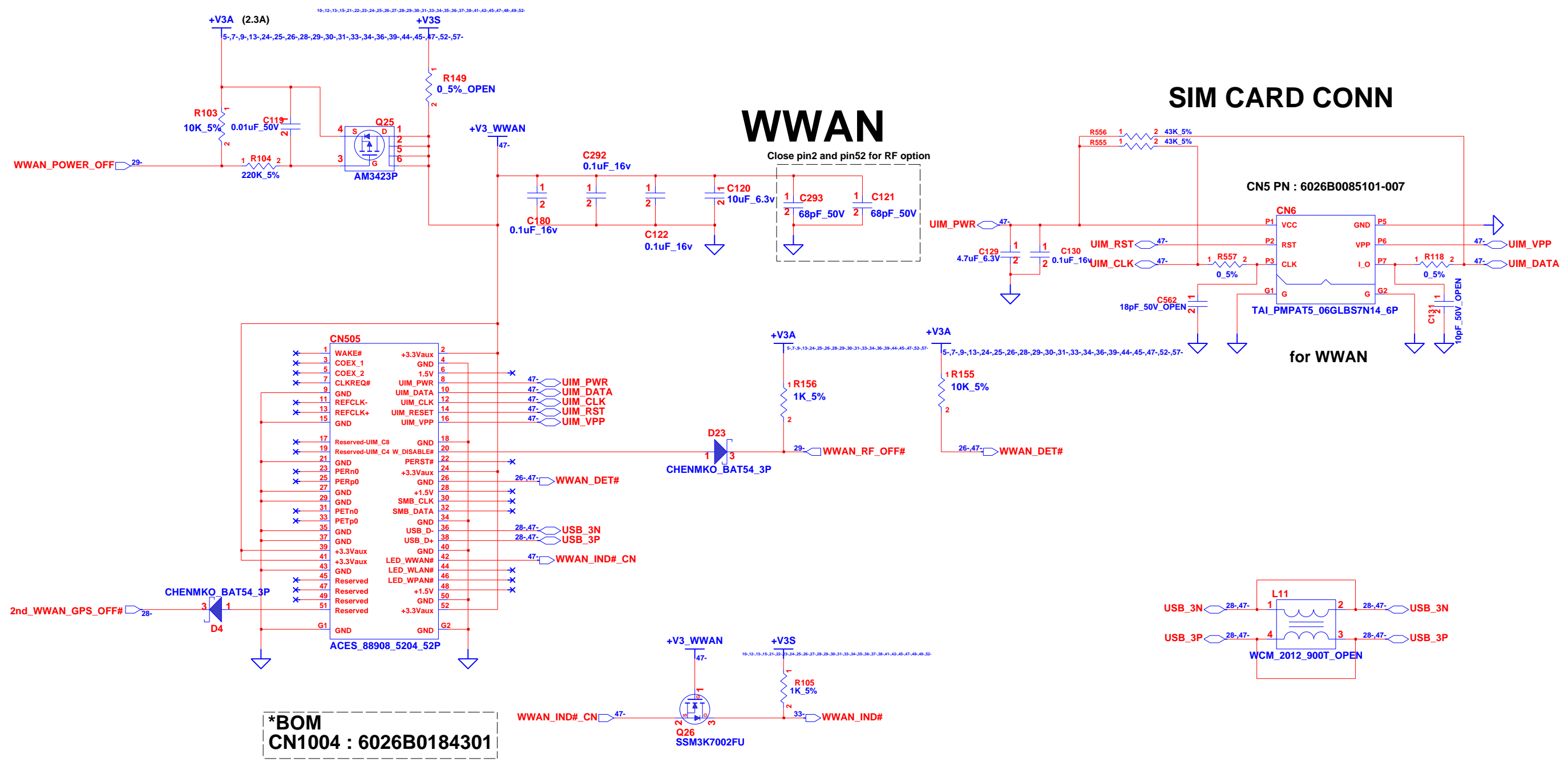

***BOM**
CN1004 : 6026B0184301

INVENTEC

TITLE			
ST133iD			
WWAN(Option)			
SIZE	CODE	DOC. NUMBER	REV
A3	CS	1310A23179-0-MTR	B
SHEET		47	OF 58

CHANGE by *Chang, Sukigo* 14-Jun-2010

OPTION PART

HARDDRIVE PROTECTION

P/N = 6019B0809001

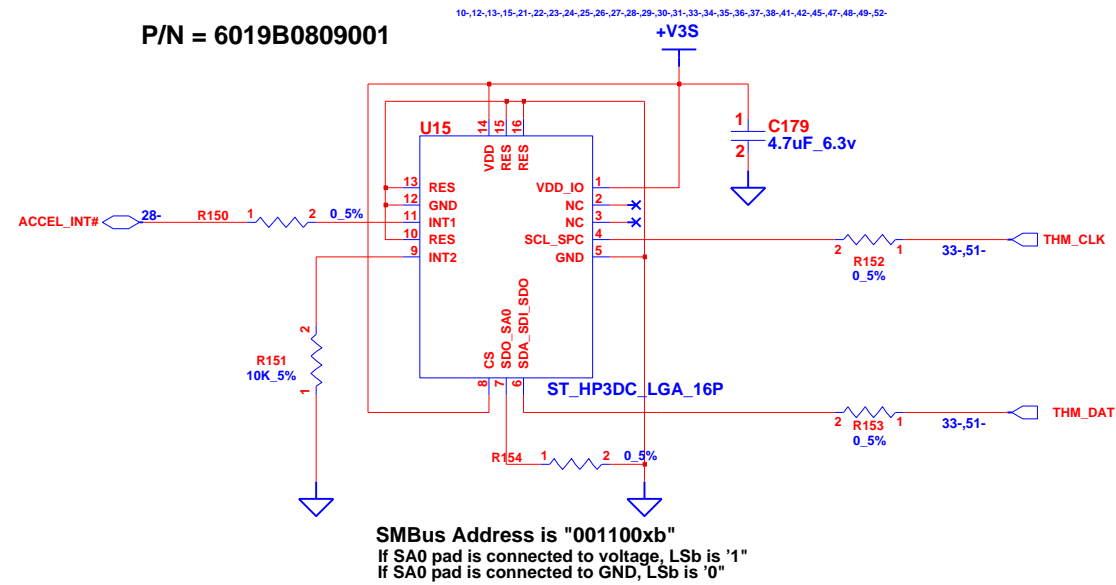

FingerPrint

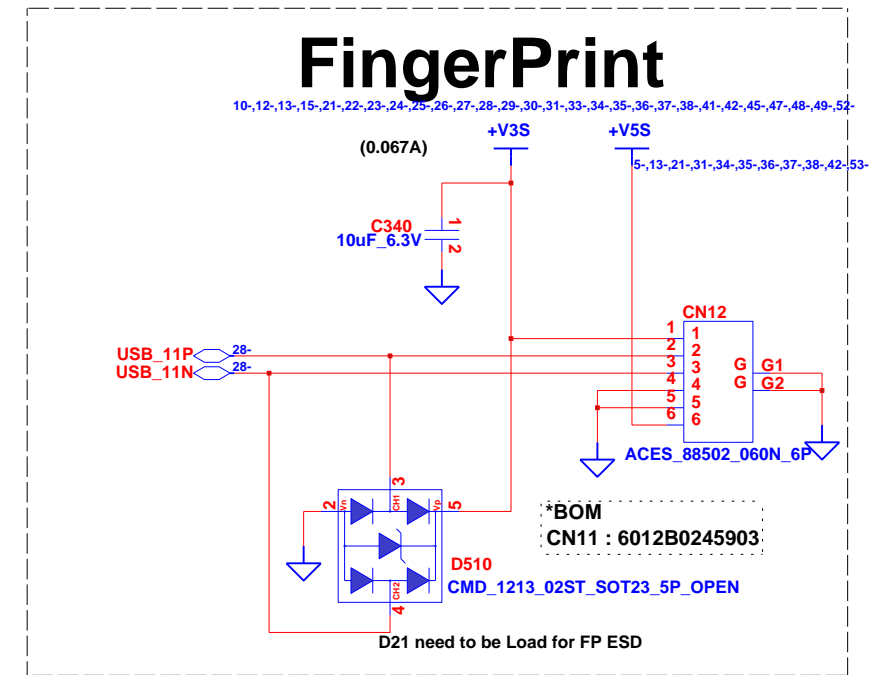

INVENTEC

TITLE **ST133iD**
 Touchscreen, FP & HD LOCK(Option)

SIZE	CODE	DOC. NUMBER	REV
A3	CS	I310A23179-0-MTR	B
SHEET		48	OF 58

CHANGE by *Chang, Sukigo* 14-Jun-2010

MEM_ID3	MEM_ID2	MEM_ID1	MEM_ID0	vendor
R15454	R15453	R15452	R15451	
0	0	0	1	Samsung(512MB)
0	0	1	1	hynix (512MB)
0	0	0	0	Samsung(1G)
0	0	1	0	hynix (1G)
0	1	1	0	Samsung(1G) C-die

(Default)

STRAPS	PIN	Description of default settings
TX_PWRS_ENB	GPIO0	PCIe full TX output swing.
TX_DEEMPH_EN	GPIO1	PCIe transmitter de-emphasis enabled.
BIF_GEN2_EN_A	GPIO2	PCIe GEN2 enabled
BIF_DEBUG_ACCESS	GPIO4	Debug signals muxed out.
BIF_VGA_DIS	GPIO7_BLON	Control Backlight On / Off
BIF_VGA_DIS	GPIO9	VGA ENABLED
ROMIDCFG(2:0)	GPIO[13:11]	Memory aperture size select.

If GPIO_22_EN = 0 , then GPIO[13:11] defines the primary memory aperture size.

GPIO_13	GPIO_12	GPIO_11	Memory aperture size
0	0	1	512MB / 256MB (Default)
1	1	0	reserved

110mA

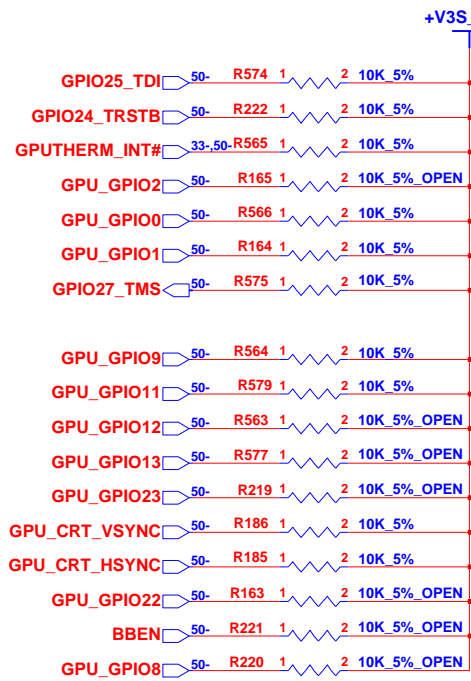
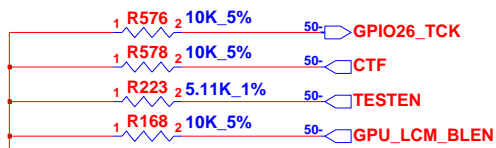

CFT: GPU Critical temperature shang down 110C

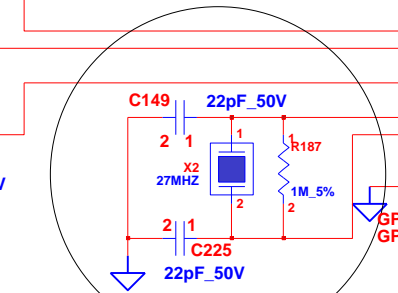

POW_SW1	POW_SW0	+VDDC_GPU
0	0	1.1V
0	1	1V
1	0	0.95V
1	1	0.9V

CHANGE TO 6018B0046201(5*3.2)

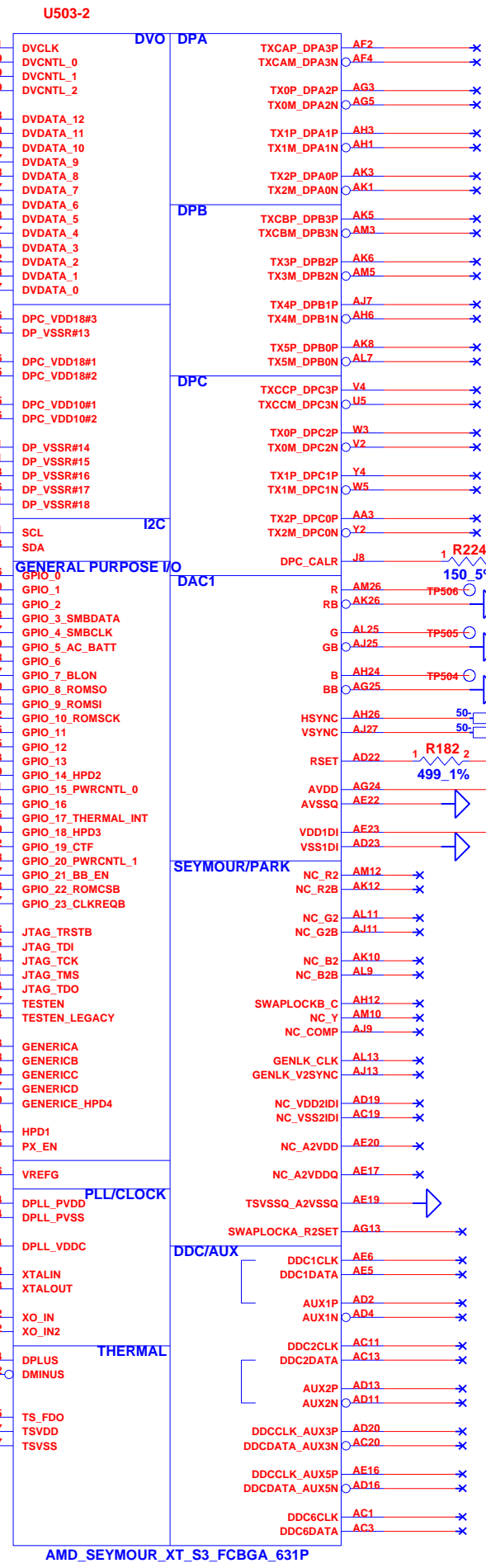
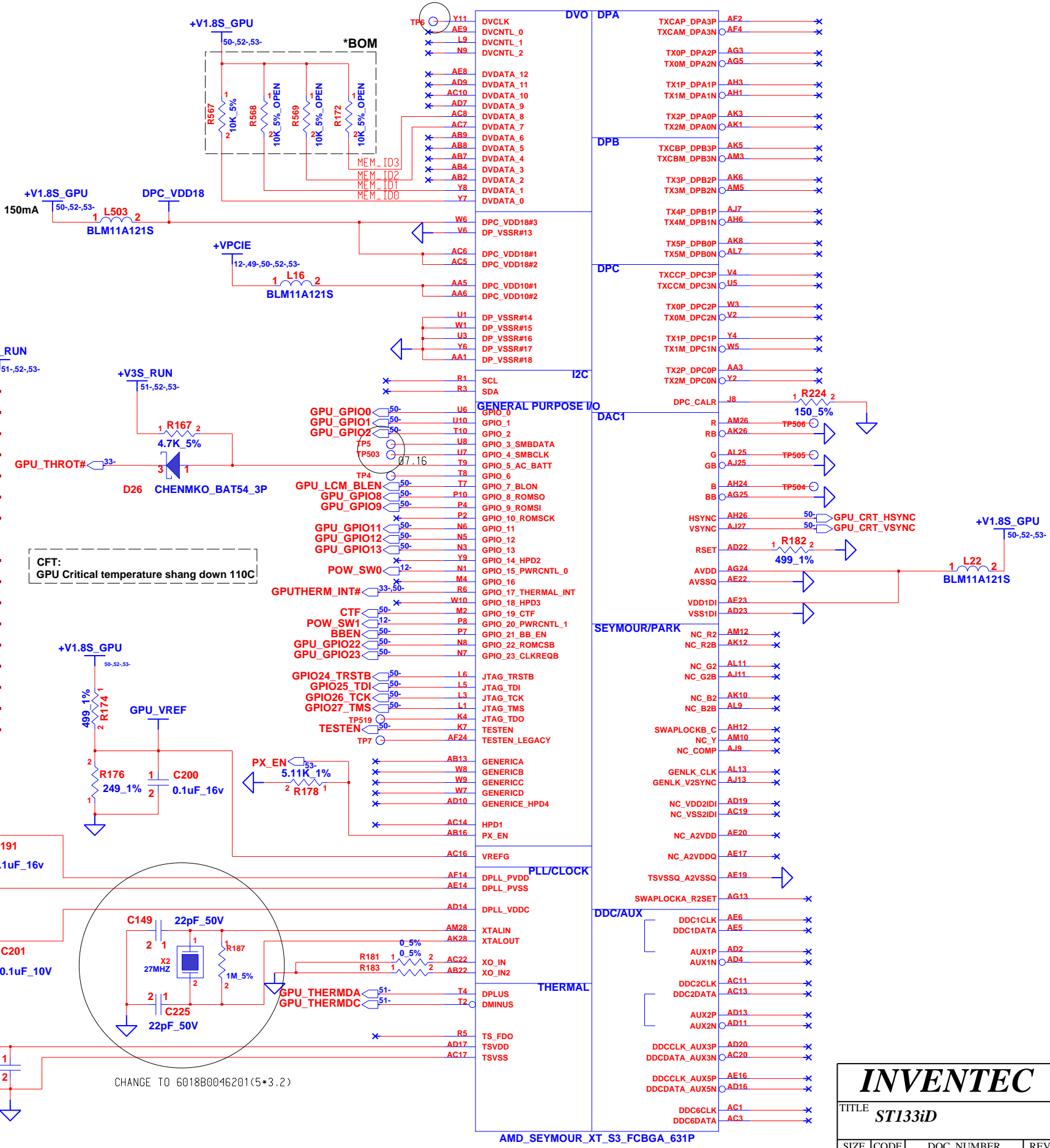

INVENTEC
TITLE ST133iD

SIZE	CODE	DOC. NUMBER	REV
A3	CS	1310A23179-0-MTR	B

CHANGE by Chang, Sukigo 14-Jun-2010 SHEET 50 OF 58

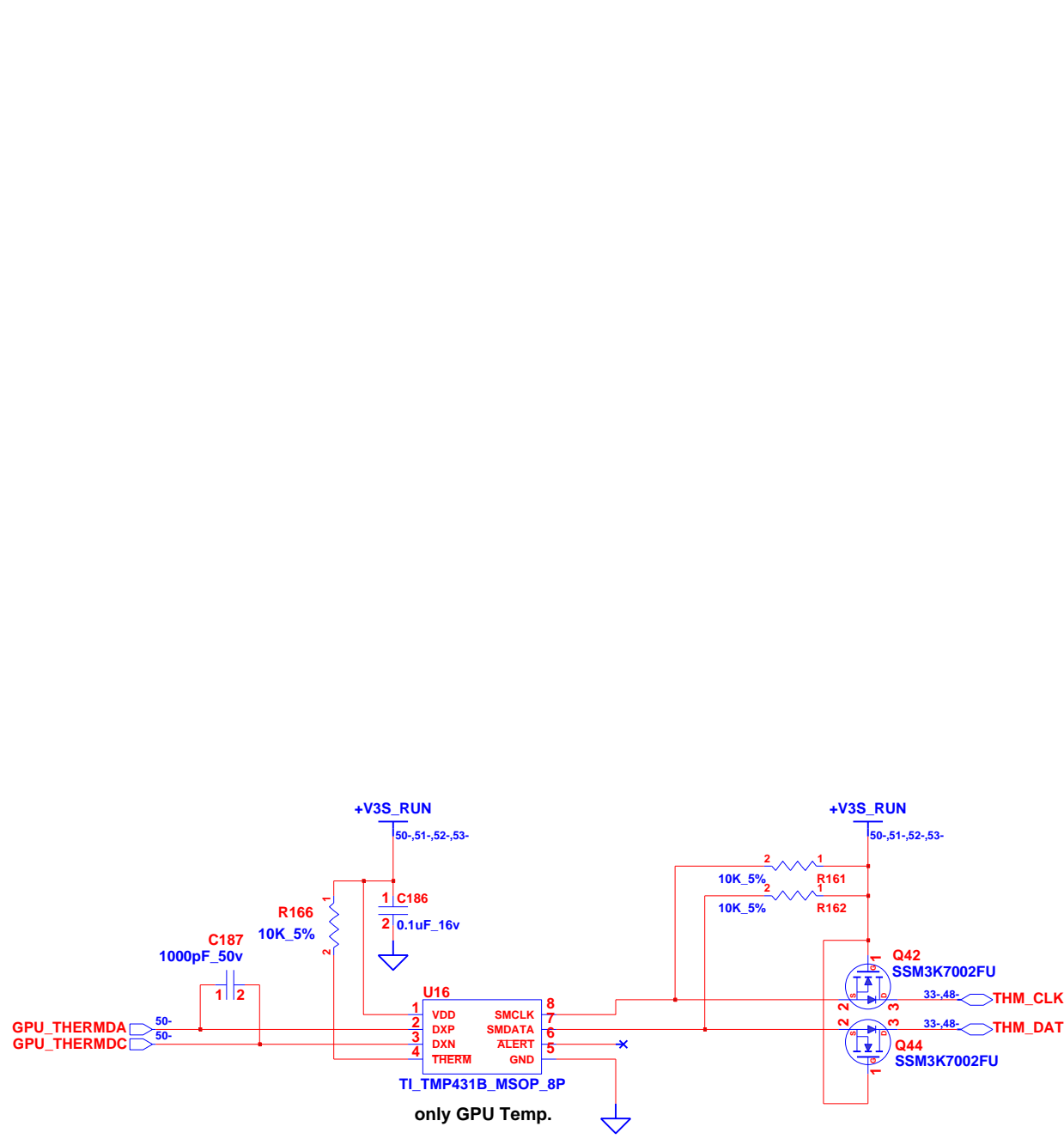

SMB Address is 100 1101

MV Buid :
 Main : 6019B0437702 EMC1402-2
 2nd : 6019B0671902 TMP431B

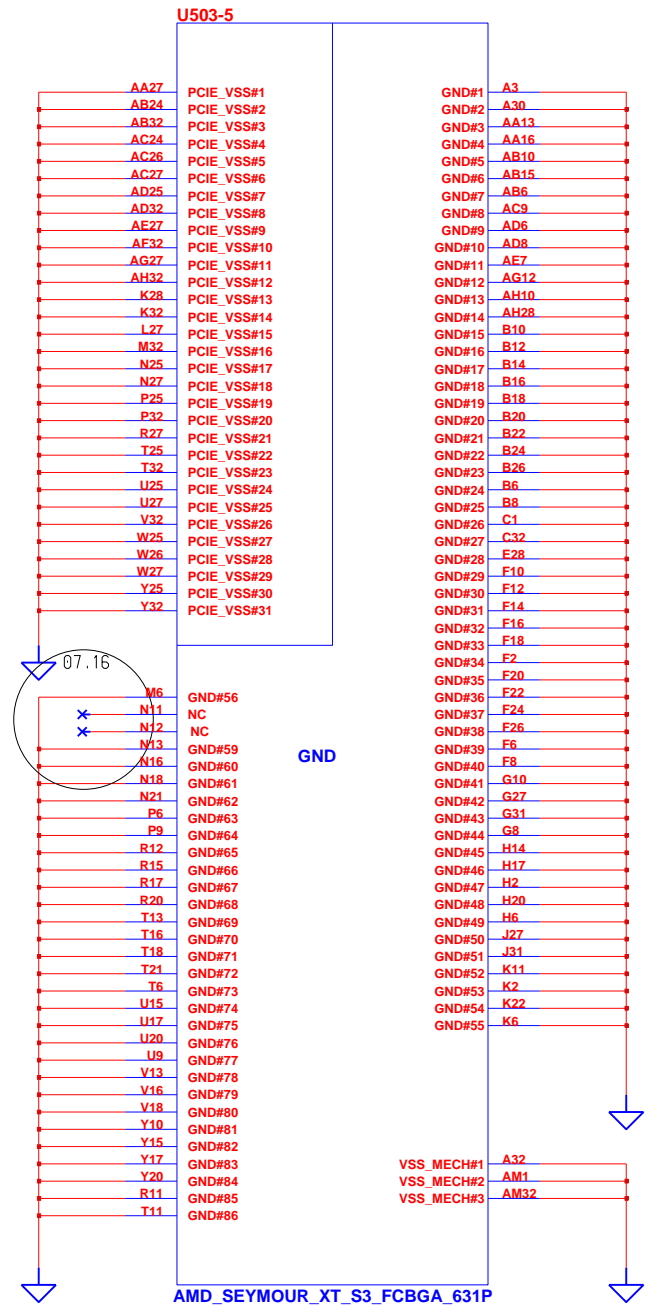

INVENTEC

TITLE **ST133iD**

SIZE	CODE	DOC. NUMBER	REV
A3	CS	1310A23179-0-MTR	B

CHANGE by *Chang, Sukigo* 14-Jun-2010

SHEET 51 OF 58

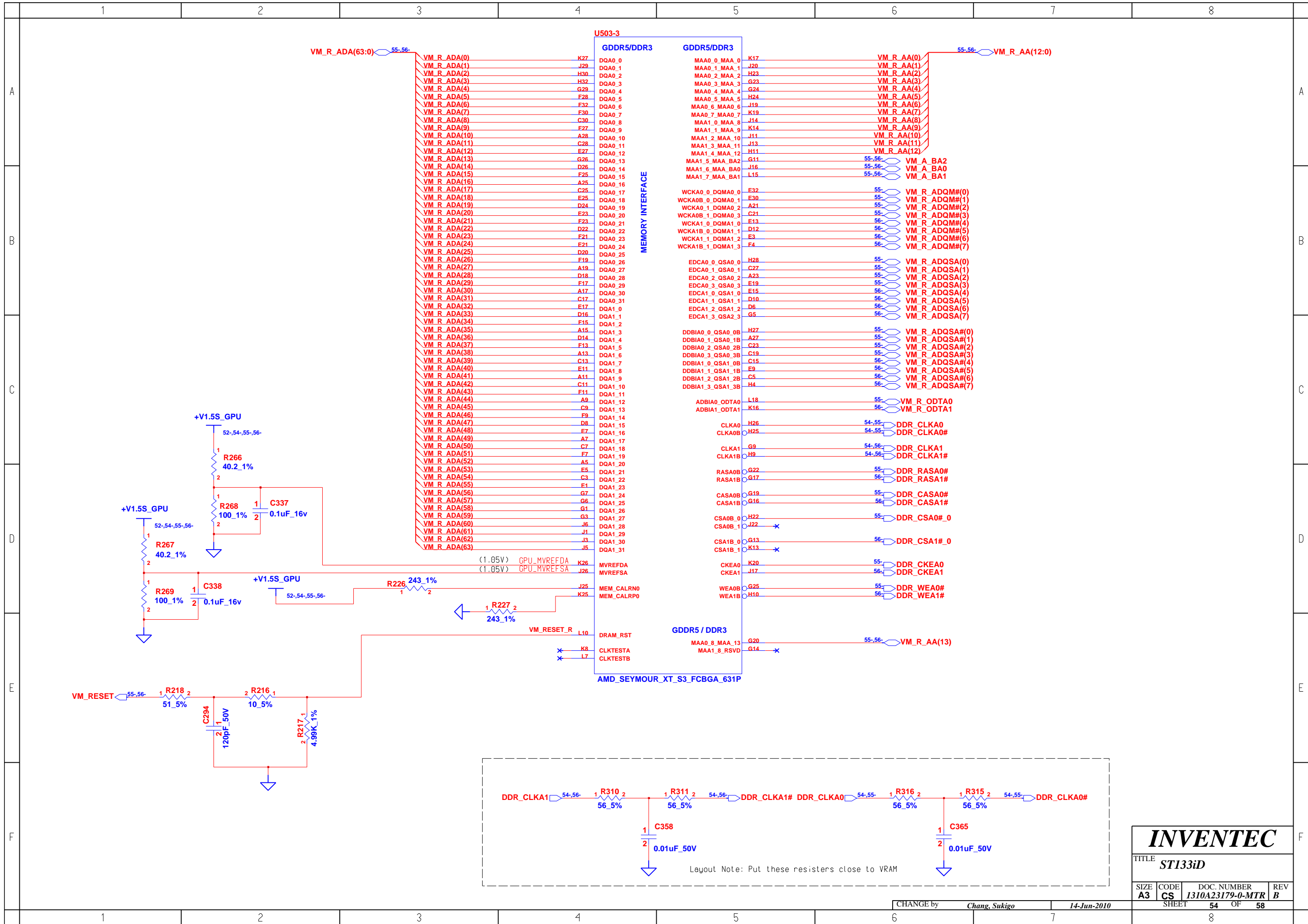

INVENTEC			
TITLE ST133iD			
SIZE A3	CODE CS	DOC. NUMBER 1310A23179-0-MTR	REV B
CHANGE by <i>Chang, Sukigo</i>		14-Jun-2010	
SHEET 54		OF 58	

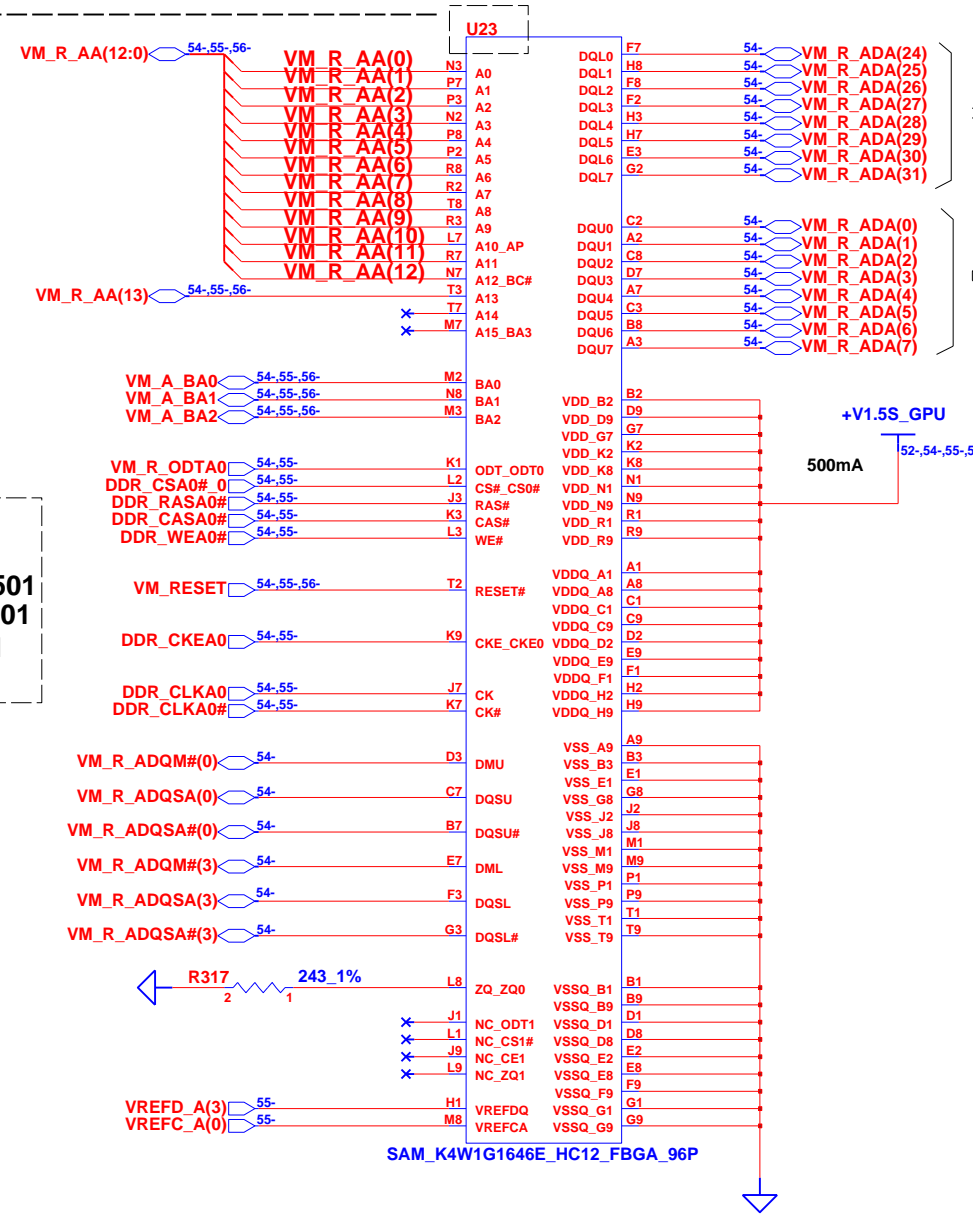
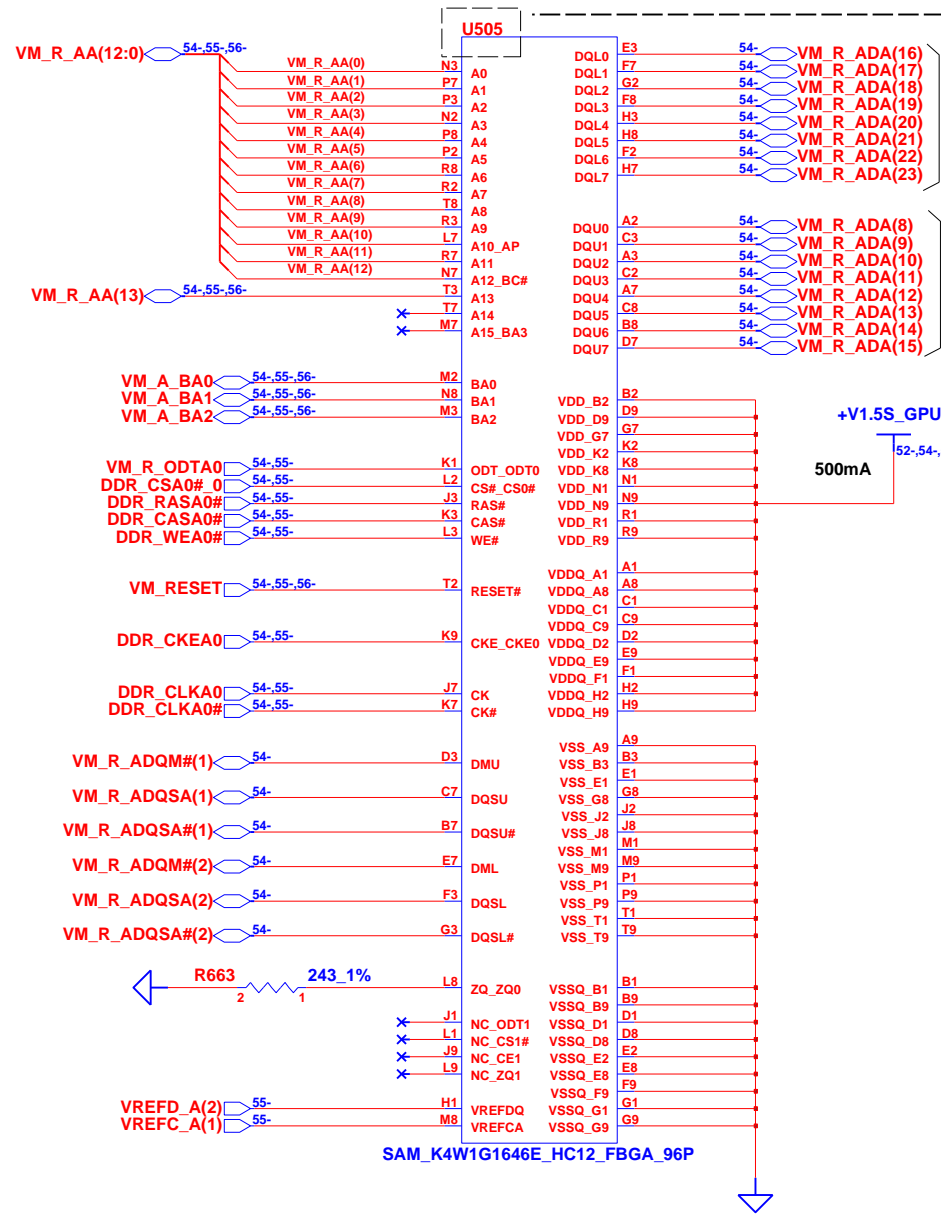

***BOM**
 Symbol P/N = 6019B0671701
 For ST133iD (HP BOM) :
 Sam 512MB P/N = 6019B0648501
 Hyn 512MB P/N = 6019B0647101
 Sam 1GB P/N = 6019B0770301
 Hyn 1GB P/N = 6019B0770201
 U23, U24, U1003, U1002

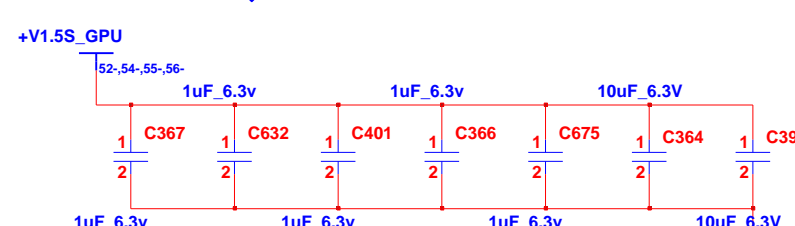
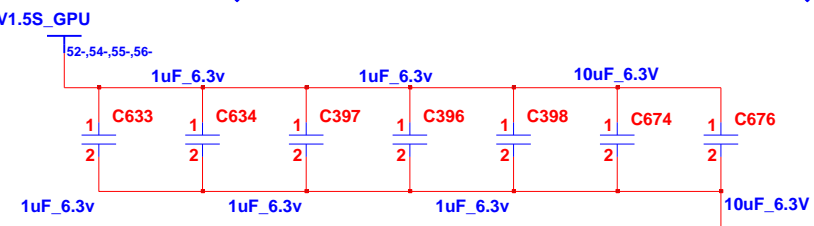
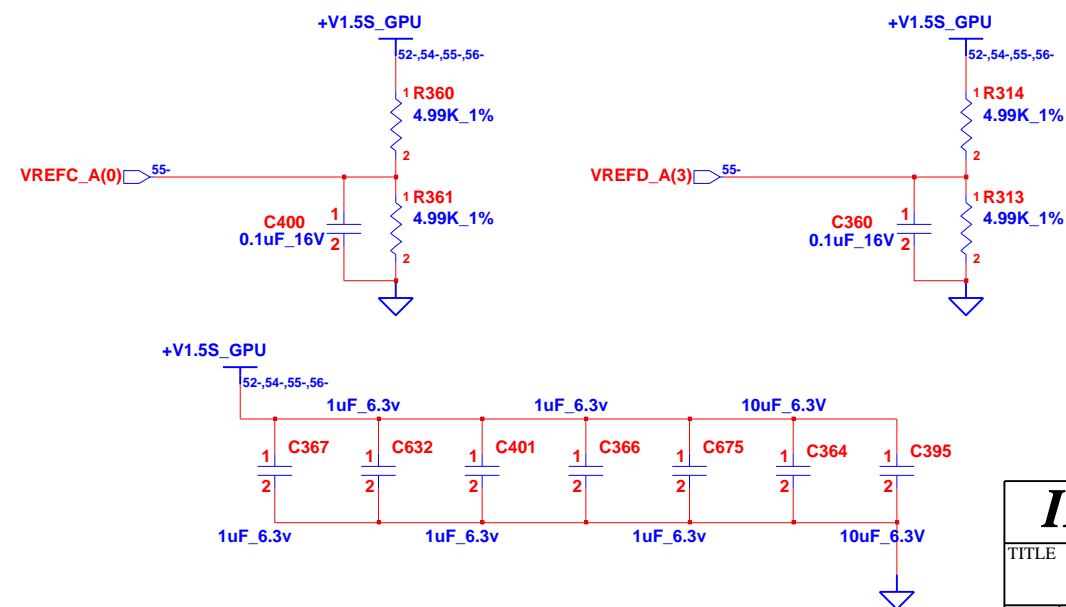
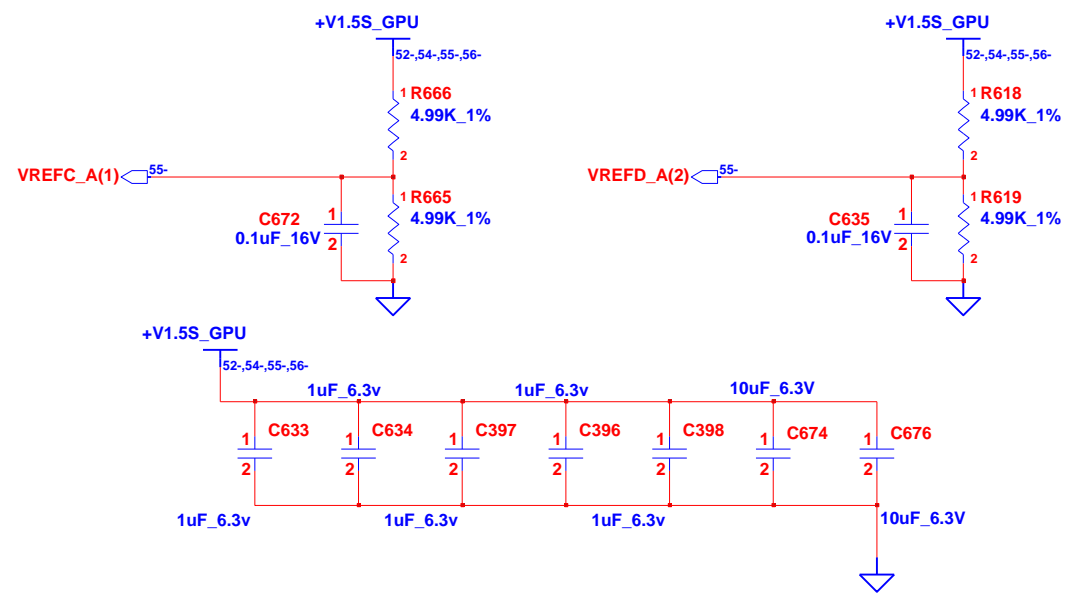

INVENTEC			
TITLE ST133iD			
SIZE A3	CODE CS	DOC. NUMBER 1310A23179-0-MTR	REV B
CHANGE by <i>Chang, Sukigo</i>		14-Jun-2010	
SHEET 55		OF 58	

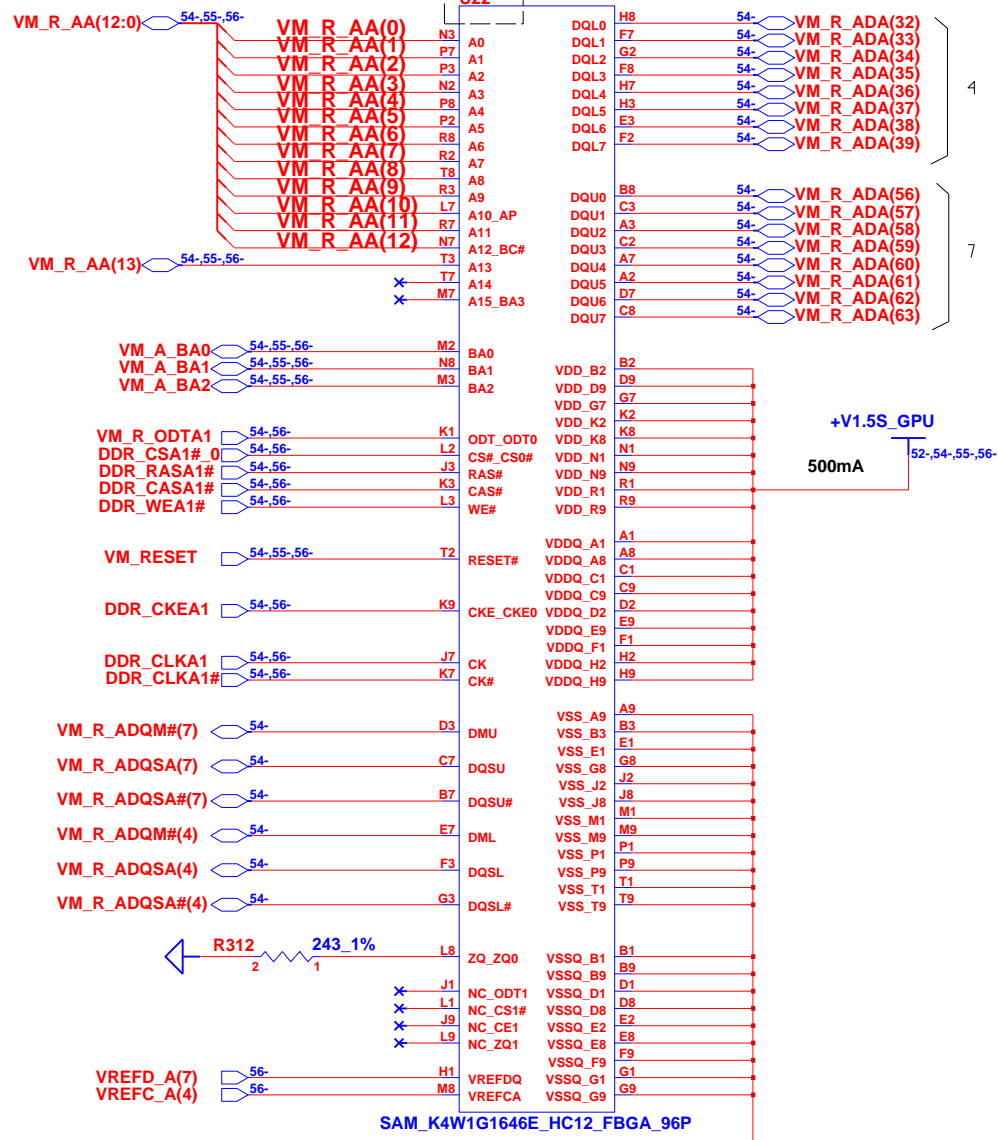

***BOM**
 Symbol P/N = 6019B0671701
 For ST133iD (HP BOM) :
 Sam 512MB P/N = 6019B0648501
 Hyn 512MB P/N = 6019B0647101
 Sam 1GB P/N = 6019B0770301
 Hyn 1GB P/N = 6019B0770201
 U23, U24, U1003, U1002

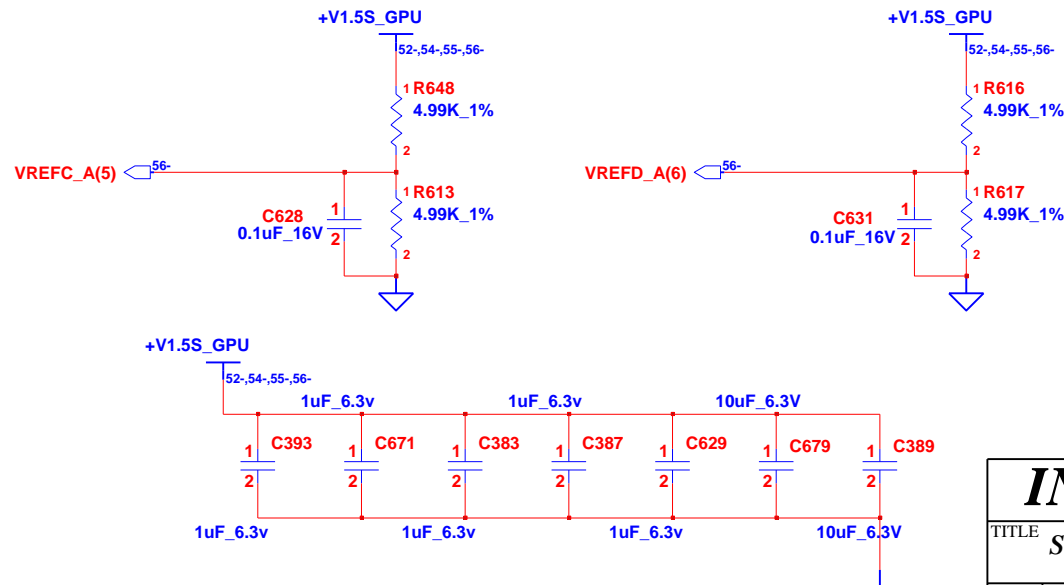
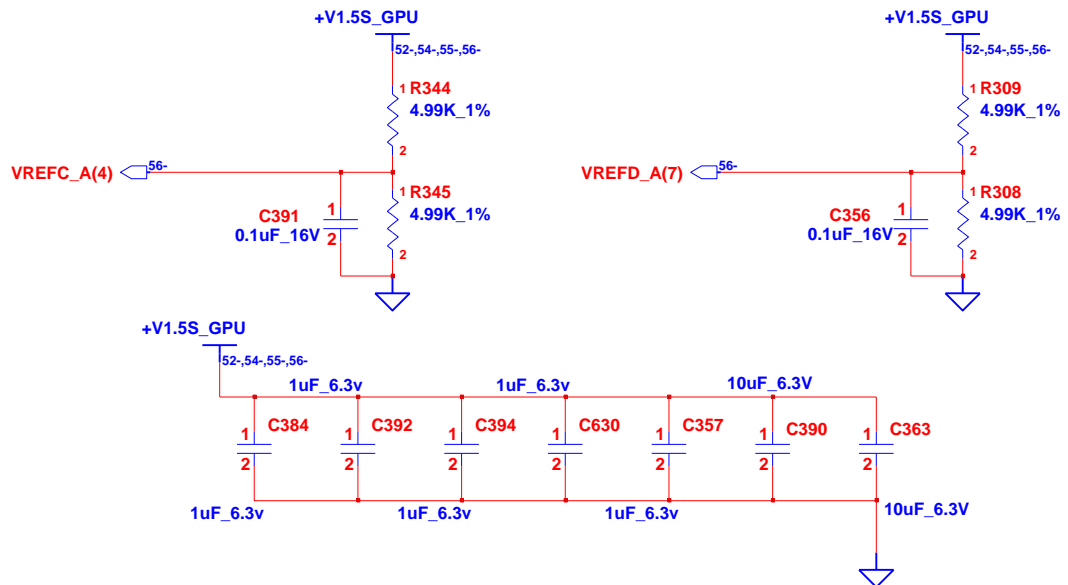
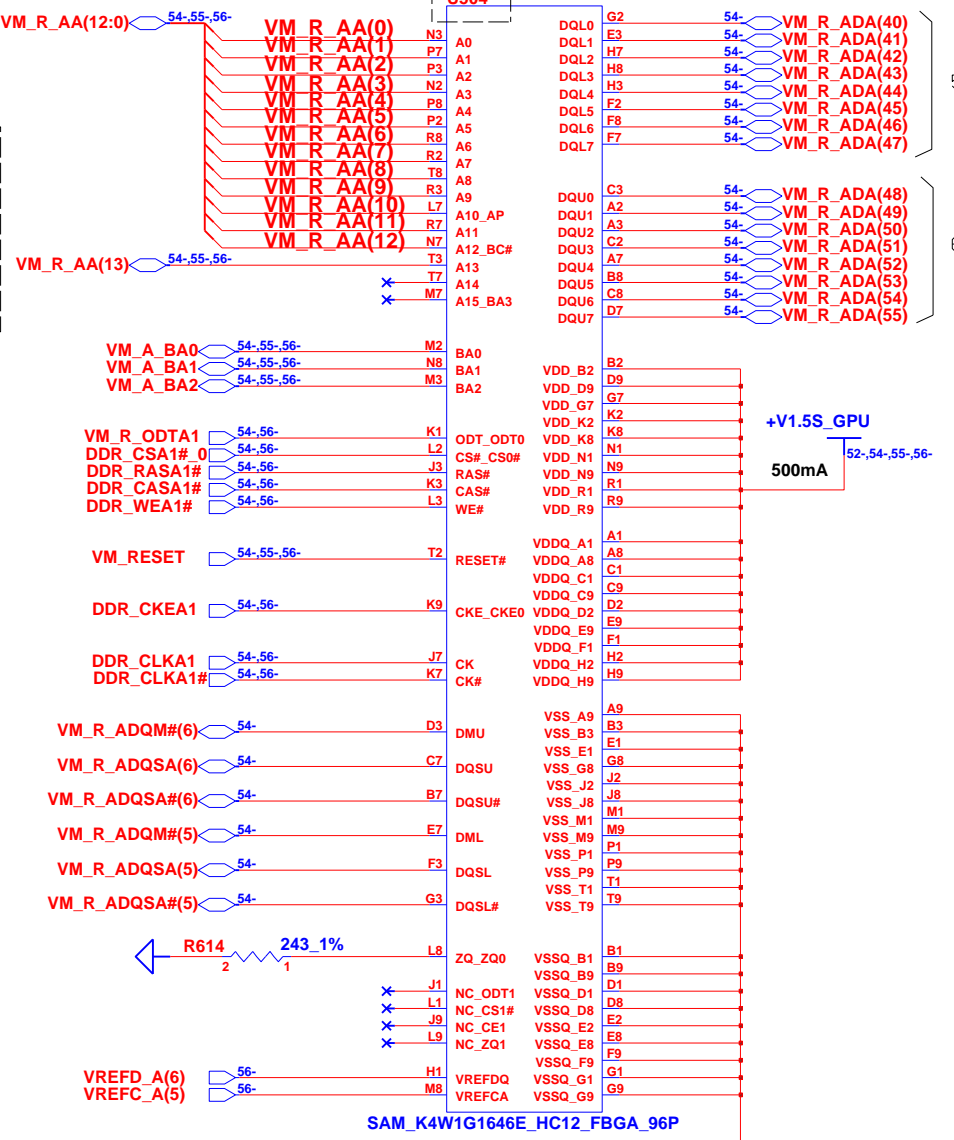

INVENTEC			
TITLE ST133iD			
SIZE A3	CODE CS	DOC. NUMBER 1310A23179-0-MTR	REV B
CHANGE by <i>Chang, Sukigo</i>		14-Jun-2010	
SHEET 56		OF 58	

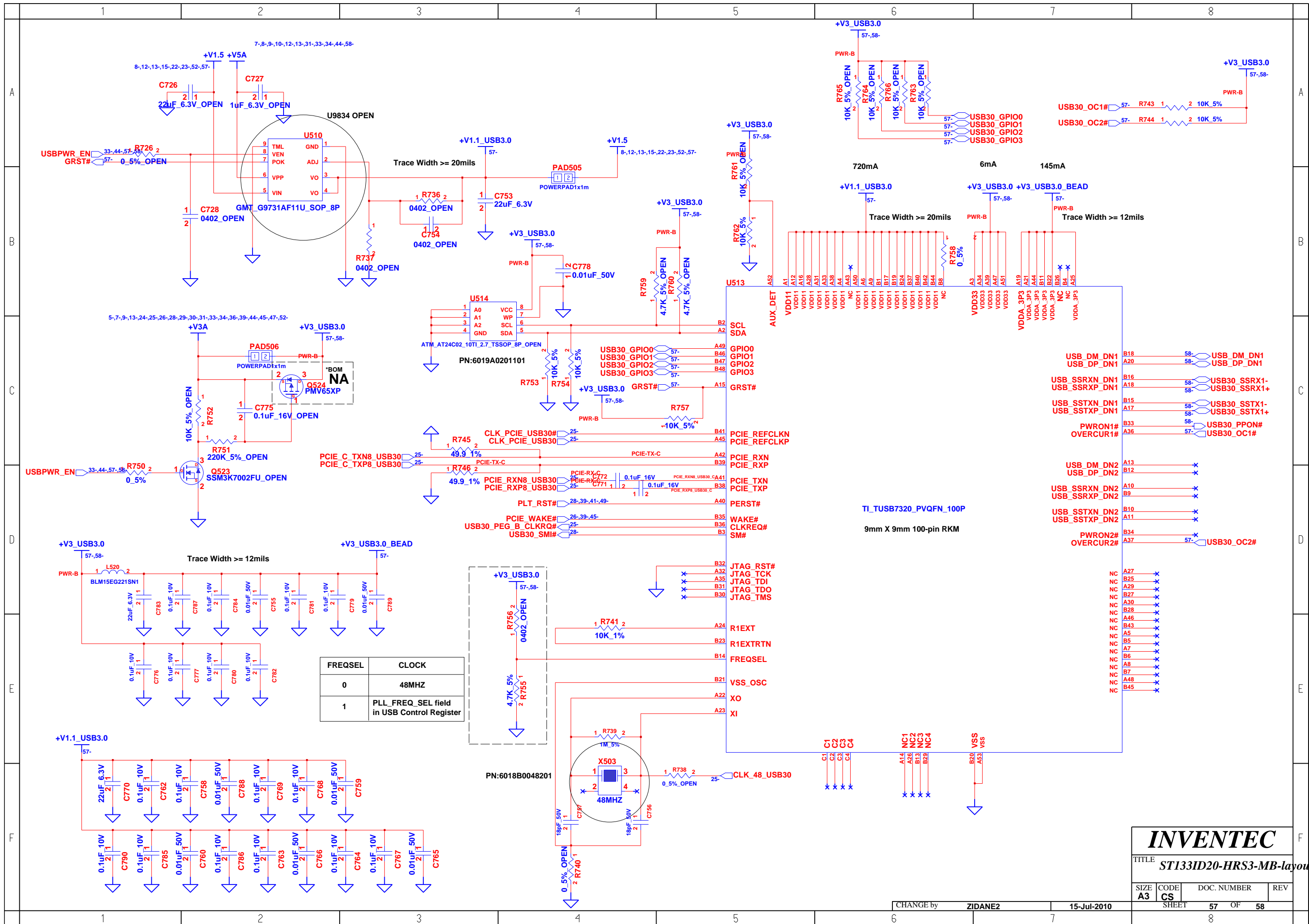

INVENTEC
 TITLE ST133ID20-HRS3-MB-layout

SIZE	CODE	DOC. NUMBER	REV
A3	CS	57 OF 58	

CHANGE by ZIDANE2 15-Jul-2010 SHEET 57 OF 58

USB 3.0 & eSATA

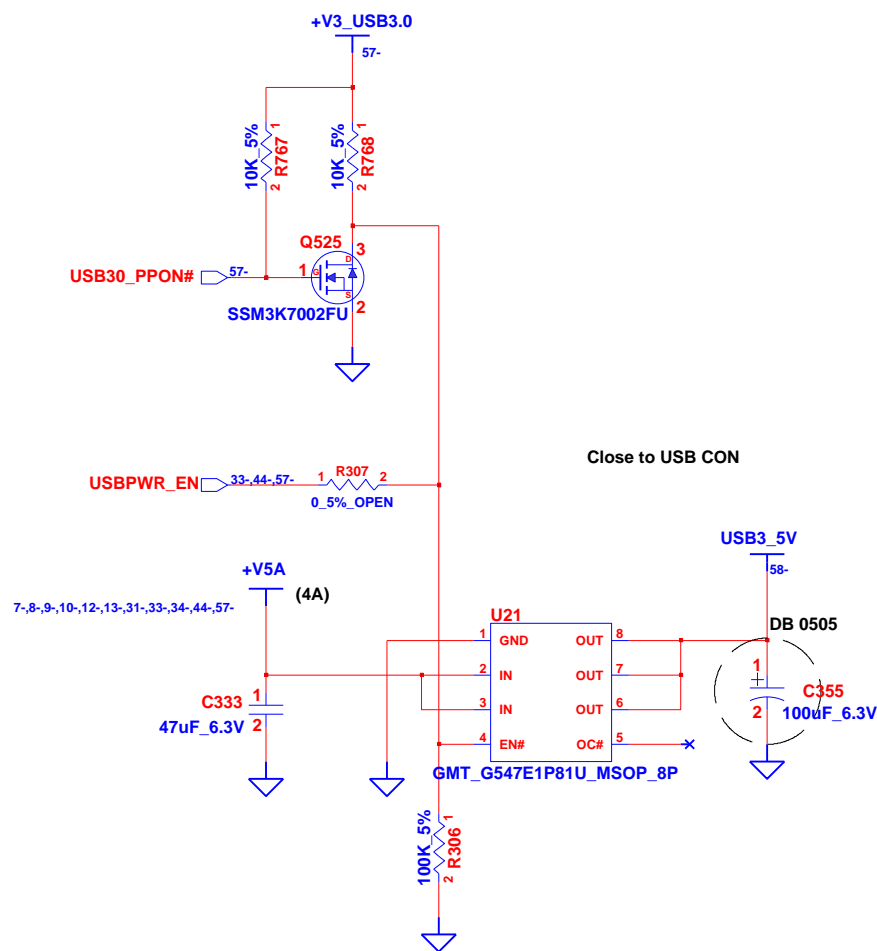
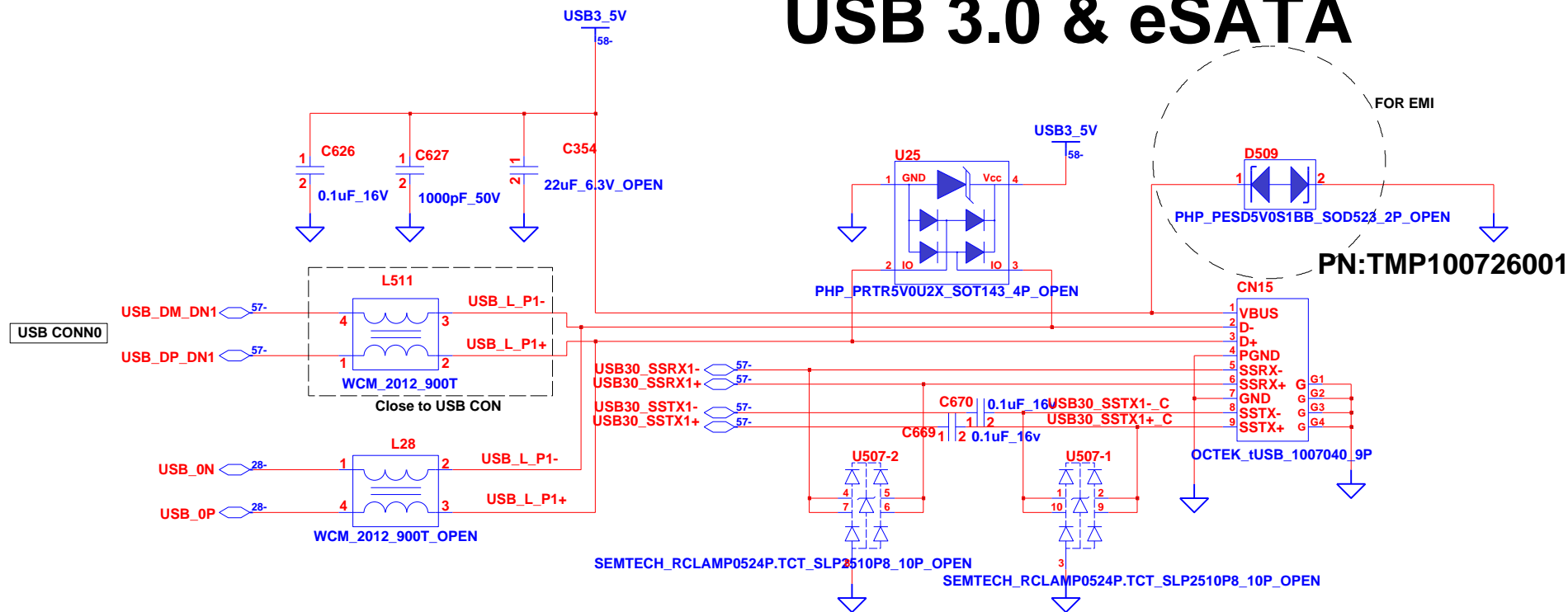

INVENTEC			
TITLE <i>ST133ID20-HRS3-MB-layout</i>			
SIZE A3	CODE CS	DOC. NUMBER	REV
SHEET		58	OF 58

CHANGE by **ZIDANE2** 8-Jul-2010