

1	2	3	4	5	6	7	8
---	---	---	---	---	---	---	---

THIS DRAWING AND SPECIFICATIONS, HEREIN, ARE THE PROPERTY OF INVENTEC CORPORATION AND SHALL NOT BE REPRODUCED, COPIED, OR USED IN WHOLE OR IN PART AS THE BASIS FOR THE MANUFACTURE OR SALE OF ITEMS WITHOUT WRITTEN PERMISSION, INVENTEC CORPORATION 2010 ALL RIGHT RESERVED

HSF Property : **Halogen-Free**

# CLASH DISCRETE

## MV BUILD

**2010.12.20**

DATE	CHANGE NO.	REV

DRAWER	EE	DATE	POWER	DATE	<b>INVENTEC</b>
DESIGN					
CHECK					
RESPONSIBLE					
TITLE					<b>CLASH</b>
SIZE =	3	VER :			
FILE NAME :	XXXX-XXXXXX-XX				SIZE <b>A3</b>
P/N	XXXXXXXXXXXX				CODE <b>CS</b>
					DOC. NUMBER
					Model No
					REV <b>A02</b>
					SHEET 1 OF 69

1	2	3	4	5	6	7	8
---	---	---	---	---	---	---	---

**TABLE OF CONTENTS**

<p>5- DC&amp; BATTERY CHARGER          6- SELECT &amp; BATTERY CONN          7- SYSTEM POWER(+V3A/+V5A)          8- SYSTEM POWER(+V1.5/+V0.75/M_REF)          9- G_POWER(+VDD_CORE/+V1.8S/TURBO)          10- SYSTEM POWER(+VCCP/+V1.05M_LAN)          11- CPU POWER(+V0.85S/+V1.05_USB30)          12- CPU POWER(+VCC_CORE)          13- CPU POWER(+VCC_CORE)          14- POWER(SLEEP)          15- POWER(SEQUENCE)          16- FAN &amp; THERMAL          17- XDP CONN          18- SANDY BRIDGE1          19- SANDY BRIDGE2          20- SANDY BRIDGE4          21- SANDY BRIDGE3          22- SANDY BRIDGE5          23- SANDY BRIDGE6          24- DDR3-DIMM0          25- DDR3-DIMM1          26- ATI-SEYMOUR-1          27- ATI-SEYMOUR-2          28- ATI-SEYMOUR-3          29- ATI-SEYMOUR-4          30- VRAM1          31- VRAM2</p>	<p>32- PCH1          33- PCH2          34- PCH3          35- PCH4          36- PCH5          37- PCH6          38- PCH7-POWER          39- PCH8-POWER          40- PCH9          41- VGA SWITCH          42- CRT / DISPLAY PORT CNTR          43- LCM &amp; WEBCAM          44- SATA HDD &amp; ODD CNTR          45- USB CHARGER &amp; ESATA COMBO          46- USB3.0 CTRL          47- USB CONN          48- BLUE TOOTH &amp; FINGER PRINTER CNTR          49- ACCELEMETOR          50- KBC &amp; SPI          51- KB &amp; POINT STICK &amp; TOUCH PAD          52- SUPER I/O          53- TPM &amp; MDC          54- LAN INTERFACE          55- LAN RJ45 CNTR          56- WWAN &amp; WLAN &amp; SIM          57- DOCKING CNTR          58- POWER &amp; WLAN_LED          59- SCREW          60- WIRELESS / QUICK WEB / MUTE LED</p>	<p>61- SMART CARD          62- EXPRESS CARD          63- EXPRESS CARD          64- AUDIO          65- EXT MIC/MIC/HP          66- 1394 &amp; SD CONN          67- CARD READER CTRL          68- LID SWITCH          69- STITCHING CAP</p>
--	--	---

<b>INVENTEC</b>			
TITLE <i>CLASH</i>			
SIZE <b>A3</b>	CODE <b>CS</b>	DOC. NUMBER <i>Model No</i>	REV <b>A02</b>
CHANGE by <i>Edi Chen</i>		8-Dec-2010	
SHEET <b>2</b>		OF <b>69</b>	
		8	

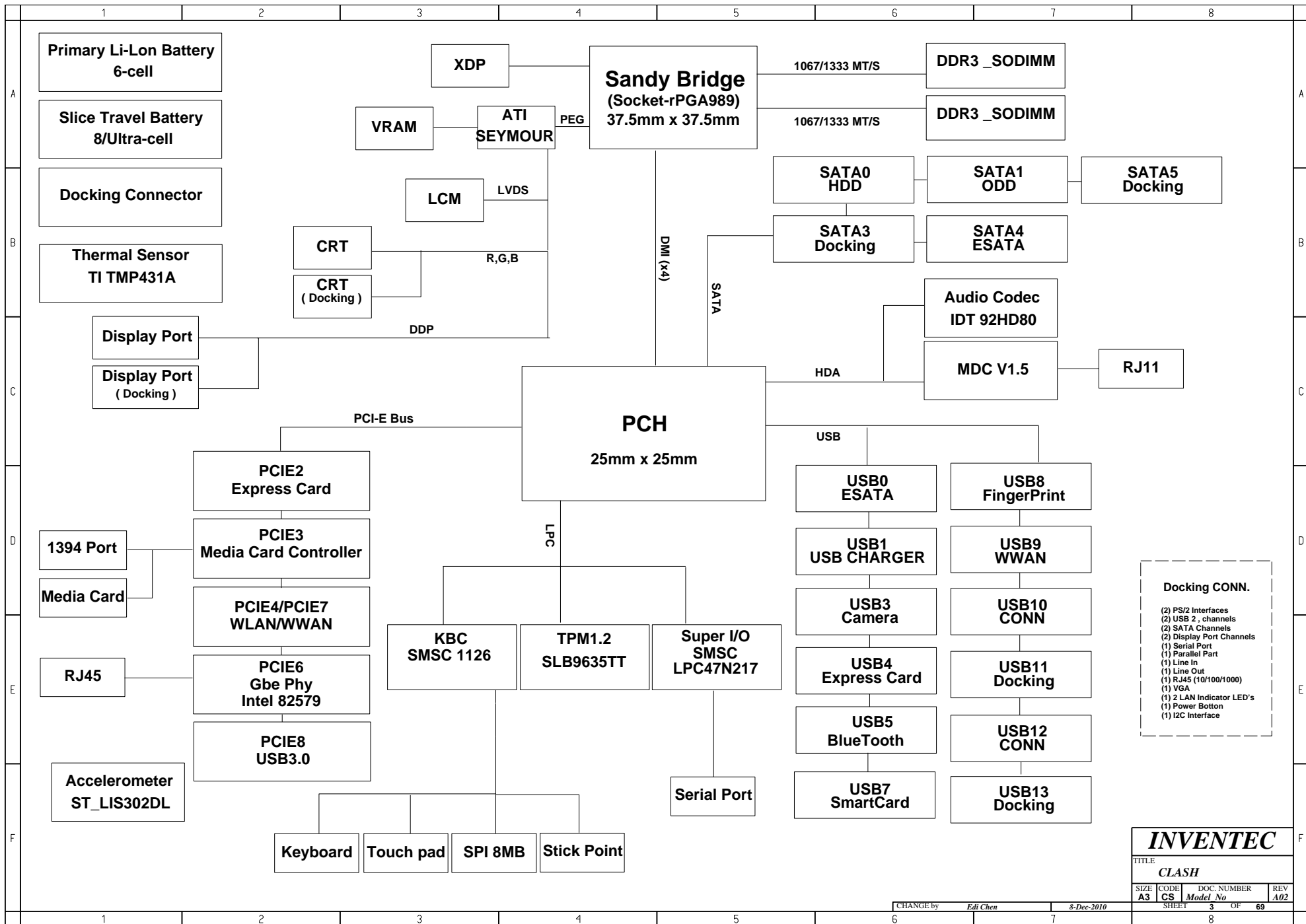

**Docking CONN.**

- (2) PS/2 Interfaces
- (2) USB 2, channels
- (2) SATA Channels
- (2) Display Port Channels
- (1) Serial Port
- (1) Parallel Port
- (1) Line In
- (1) Line Out
- (1) RJ45 (10/100/1000)
- (1) VGA
- (1) 2 LAN Indicator LED's
- (1) Power Button
- (1) I2C Interface

<b>INVENTEC</b>			
TITLE <b>CLASH</b>			
SIZE <b>A3</b>	CODE <b>CS</b>	DOC. NUMBER <i>Model No</i>	REV <b>A02</b>
CHANGE by <i>Edi Chen</i>		8-Dec-2010	
SHEET		3	OF 69

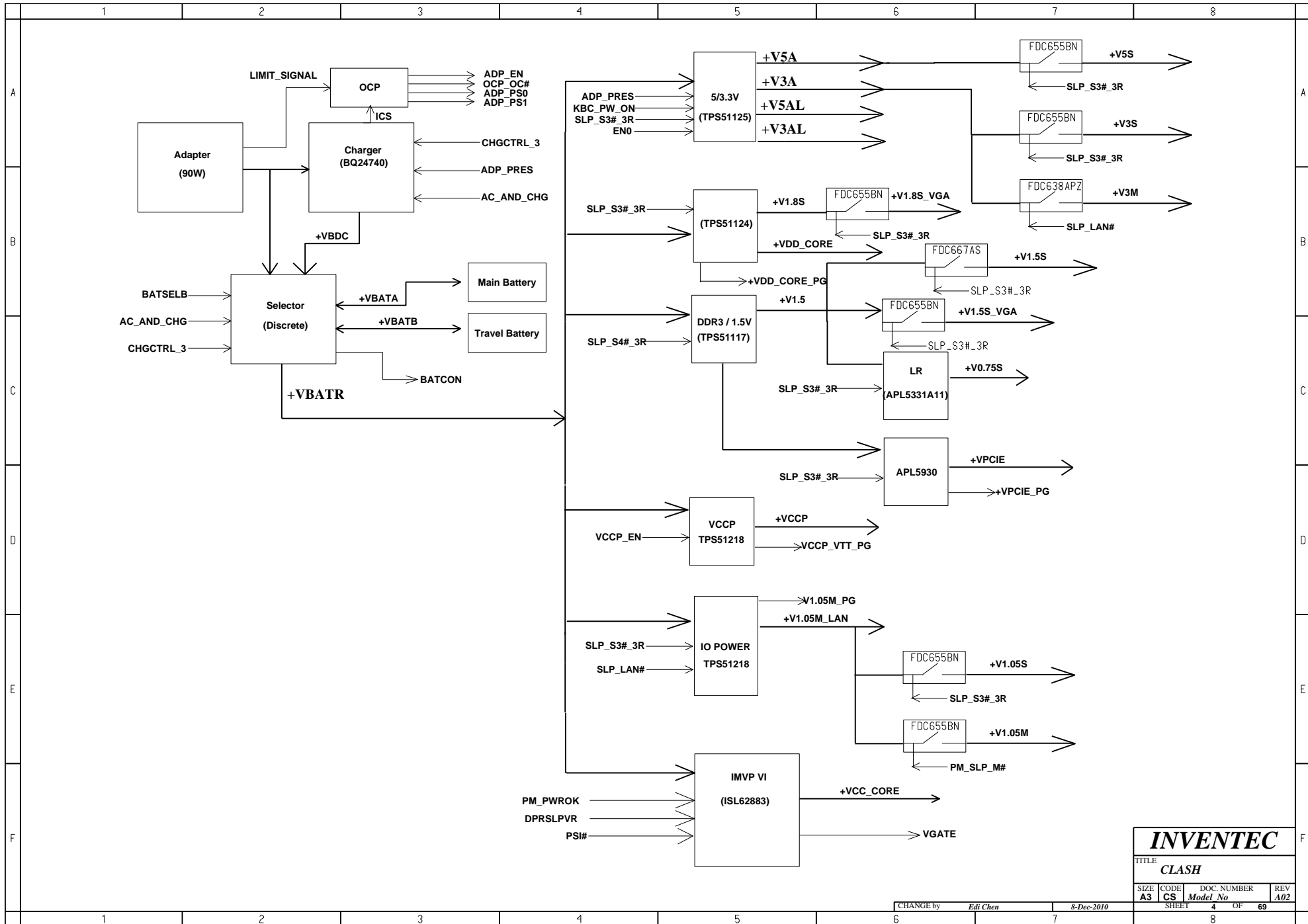

<b>INVENTEC</b>			
TITLE <b>CLASH</b>			
SIZE <b>A3</b>	CODE <b>CS</b>	DOC. NUMBER <i>Model No</i>	REV <b>A02</b>
CHANGE by <i>Edi Chen</i>		8-Dec-2010	
SHEET <b>4</b>		OF <b>69</b>	

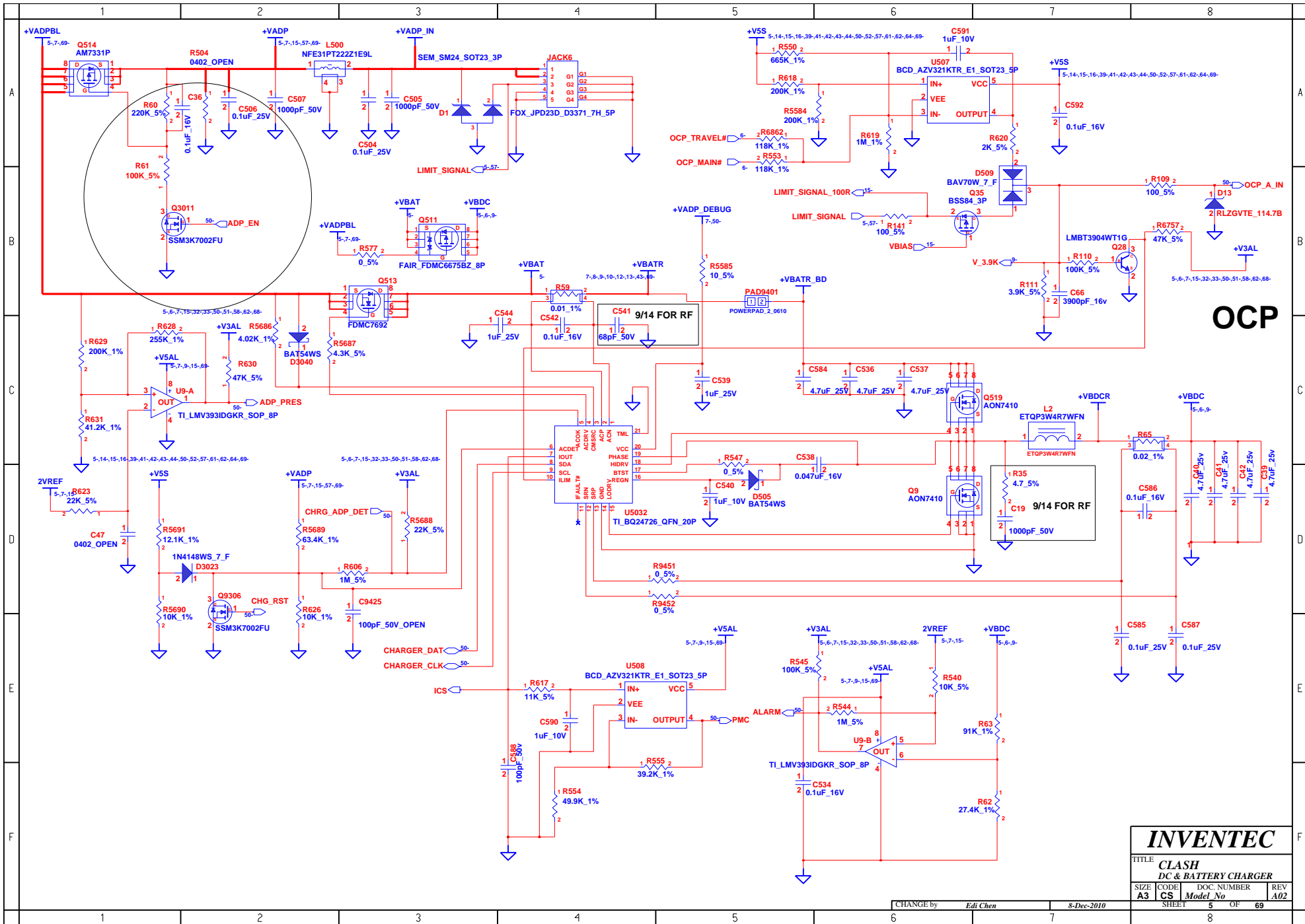

<b>INVENTEC</b>				
TITLE <b>CLASH DC &amp; BATTERY CHARGER</b>				
SIZE <b>A3</b>	CODE <b>CS</b>	DOC NUMBER <i>Model No</i>	REV <b>A02</b>	
SHEET <b>5</b>		OF <b>69</b>		

<http://sualaptop365.edu.vn>

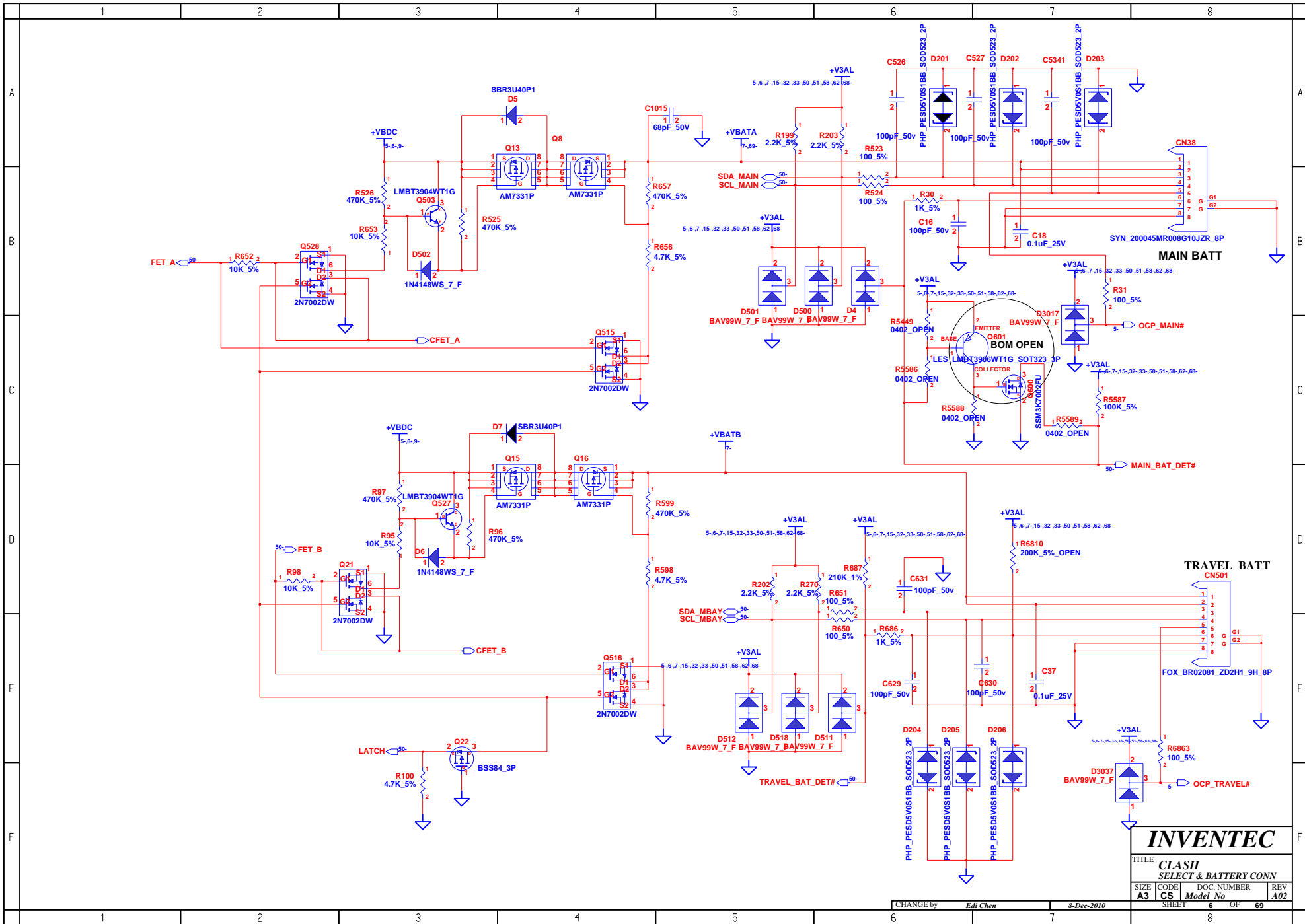

<http://sualaptop365.edu.vn>

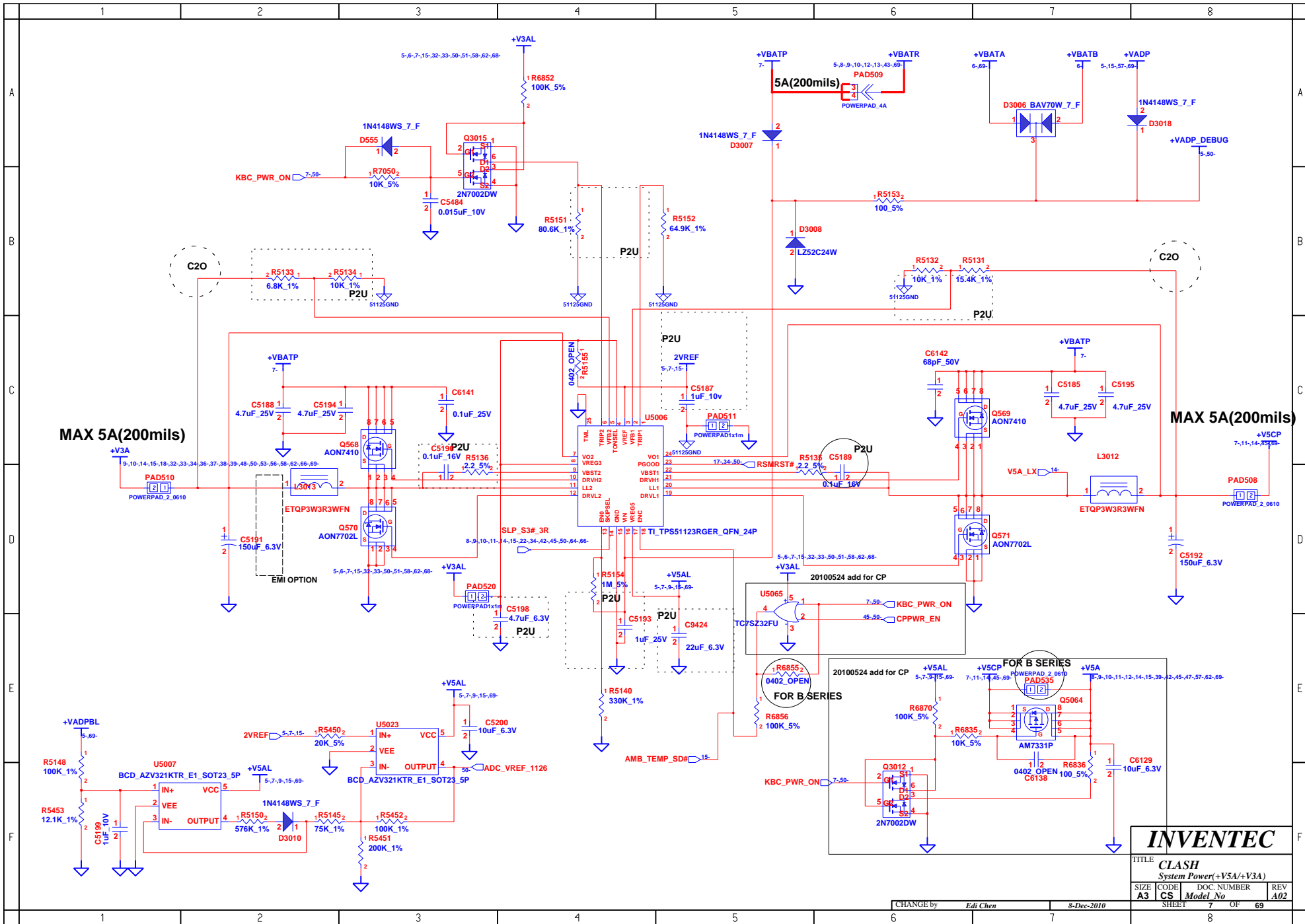

http://sualaptop365.edu.vn

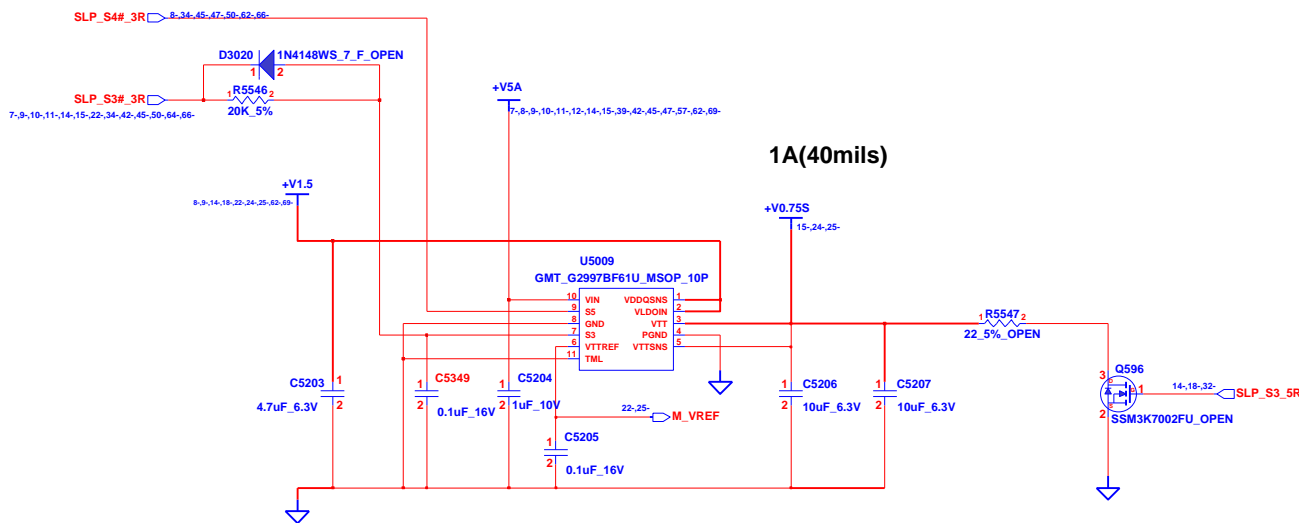
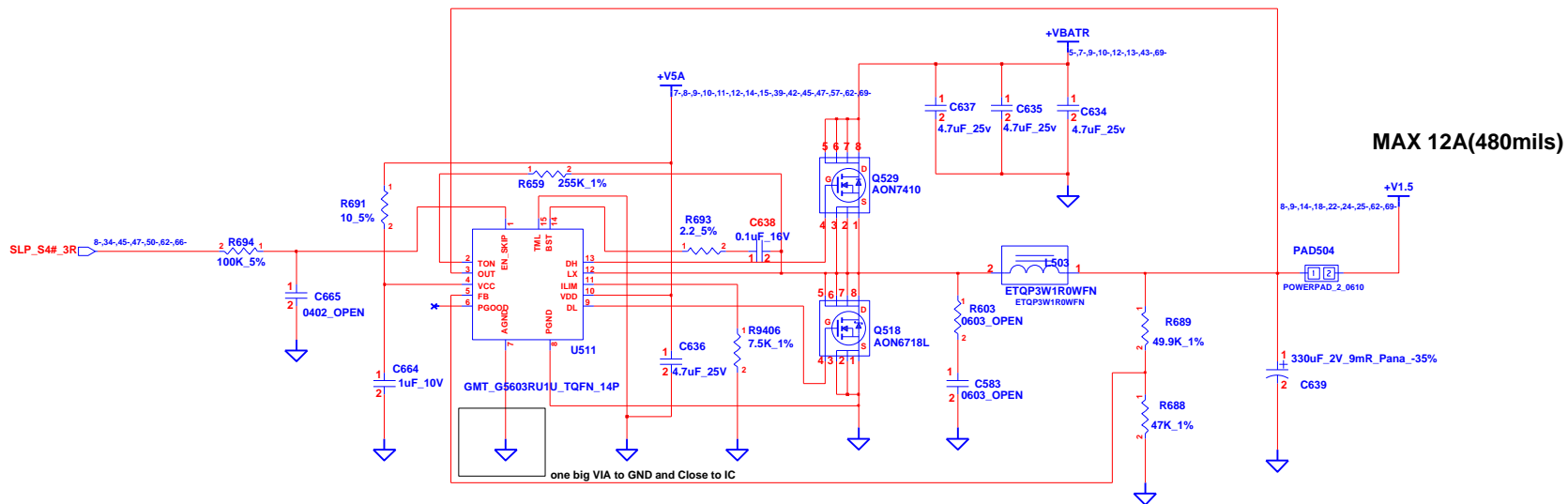

NOTE: DDR3 REGULATOR

MAX 12A(480mils)

1A(40mils)

**INVENTEC**

TITLE			
CLASH			
SYSTEM POWER(+V1.5/MREF)			
SIZE	CODE	DOC NUMBER	REV
A3	CS	Model No	A02

CHANGE by *Edi Chen* 8-Dec-2010

SHEET 8 OF 69



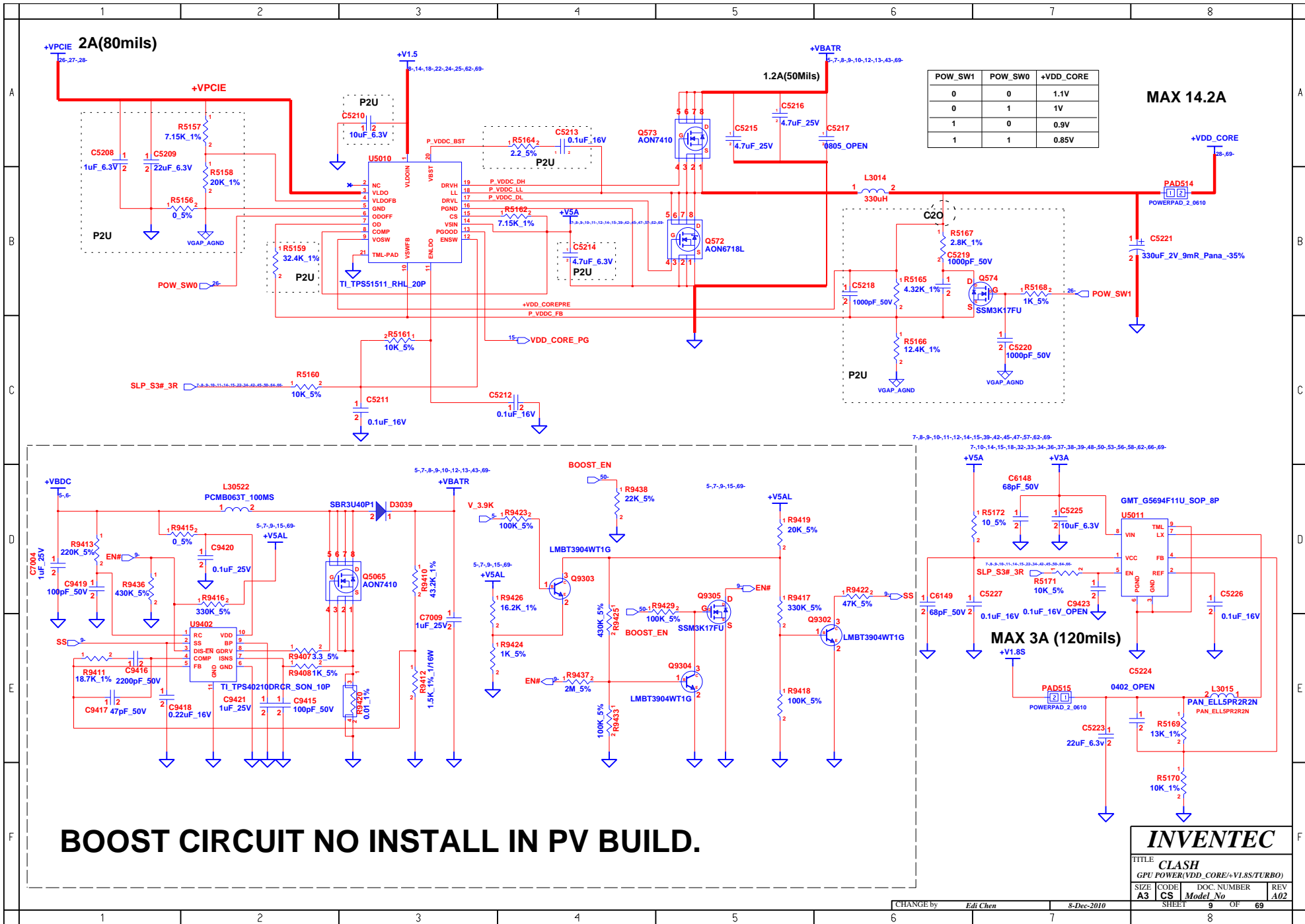

<b>INVENTEC</b>			
TITLE <b>CLASH</b>			
GPU POWER(+VDD_CORE/+V1.S/TURBO)			
SIZE <b>A3</b>	CODE <b>CS</b>	DOC NUMBER <b>Model No</b>	REV <b>A02</b>
CHANGE by <b>Edi Chen</b>		8-Dec-2010	
SHEET <b>9</b>		OF <b>69</b>	

<http://sualaptop365.edu.vn>

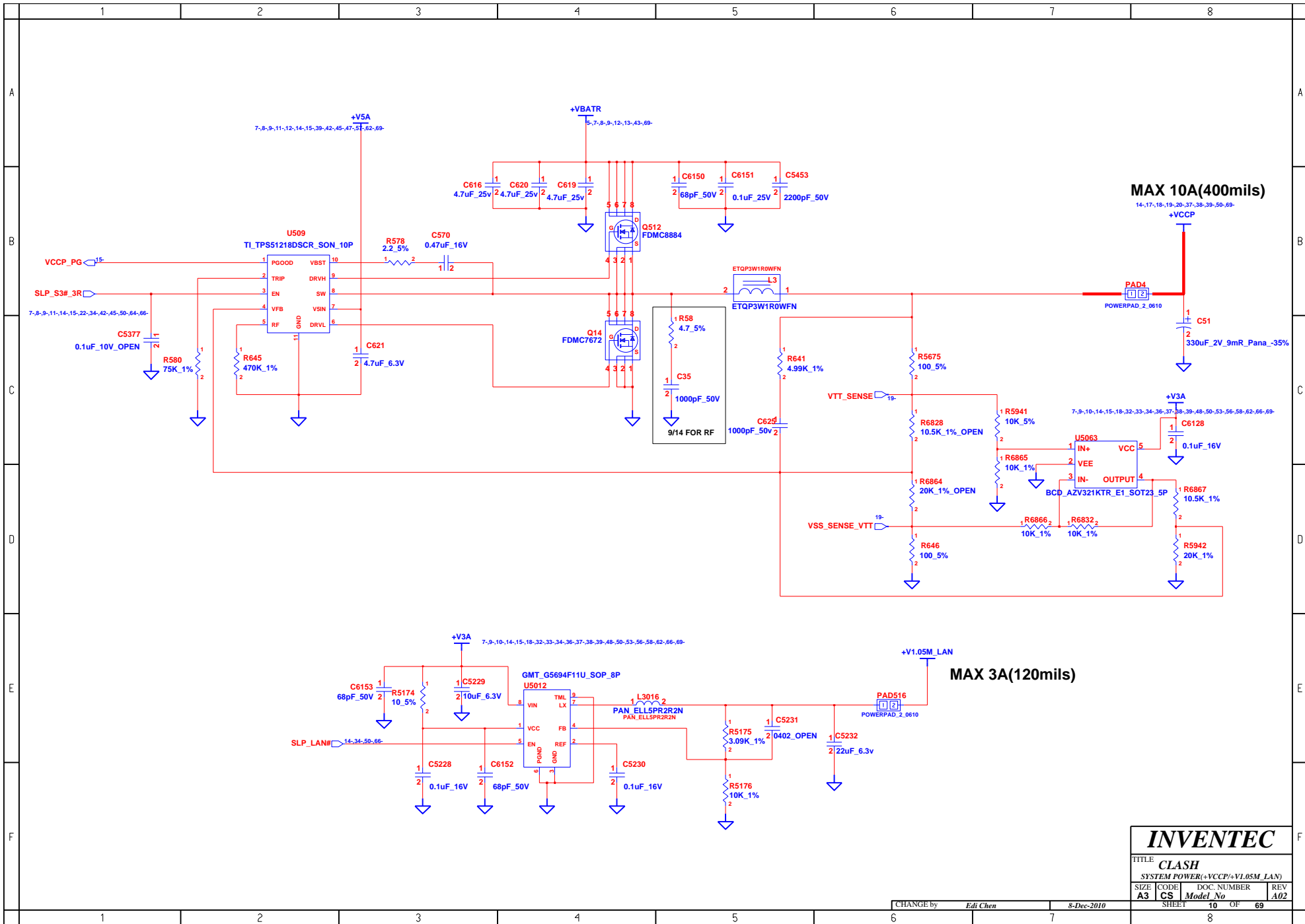

<b>INVENTEC</b>			
TITLE <b>CLASH</b>			
SYSTEM POWER(+VCCP/+V1.05M_LAN)			
SIZE <b>A3</b>	CODE <b>CS</b>	DOC NUMBER <b>Model No</b>	REV <b>A02</b>
CHANGE by <i>Edi Chen</i>		8-Dec-2010	
SHEET <b>10</b>		OF <b>69</b>	

<http://sualaptop365.edu.vn>

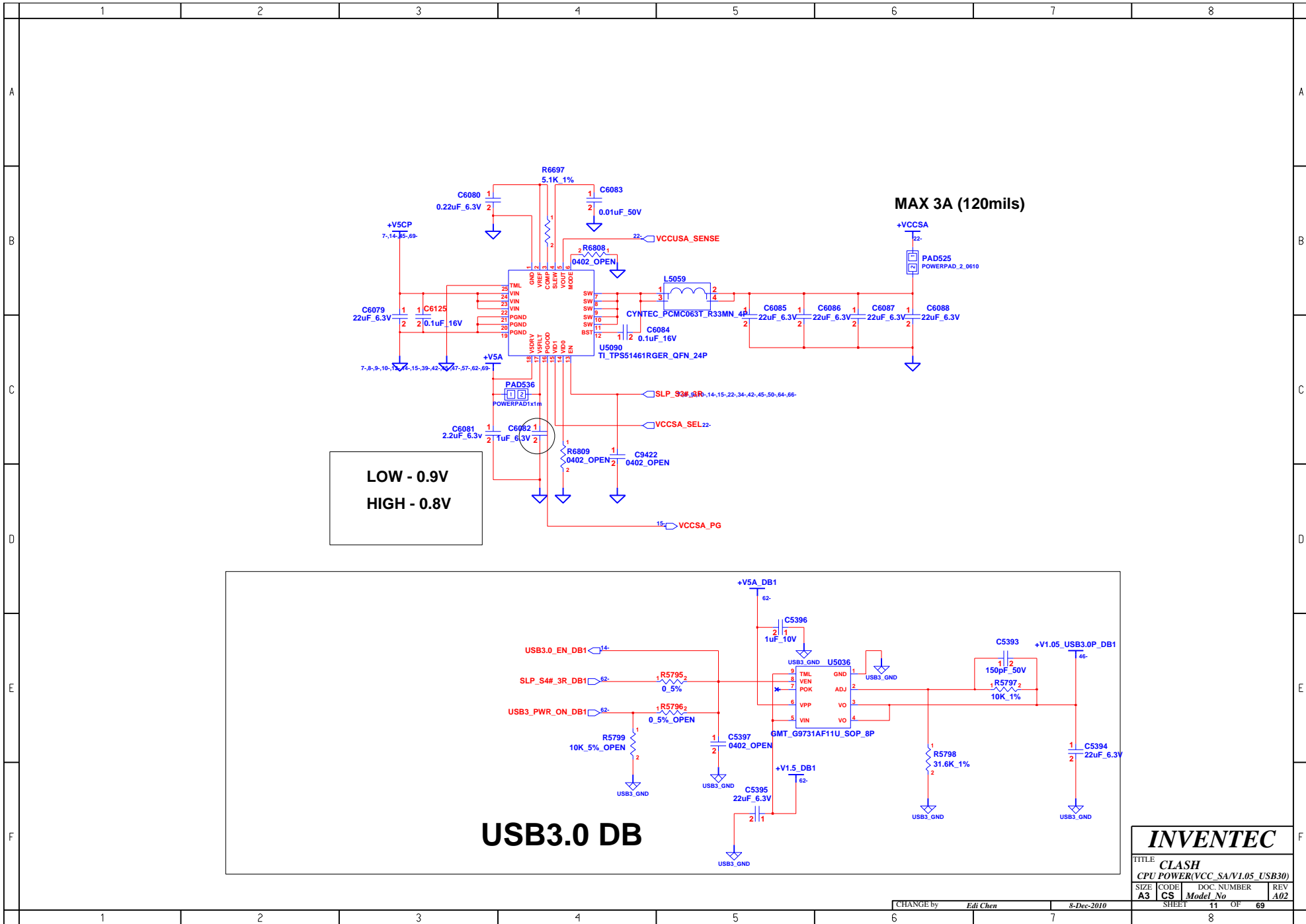

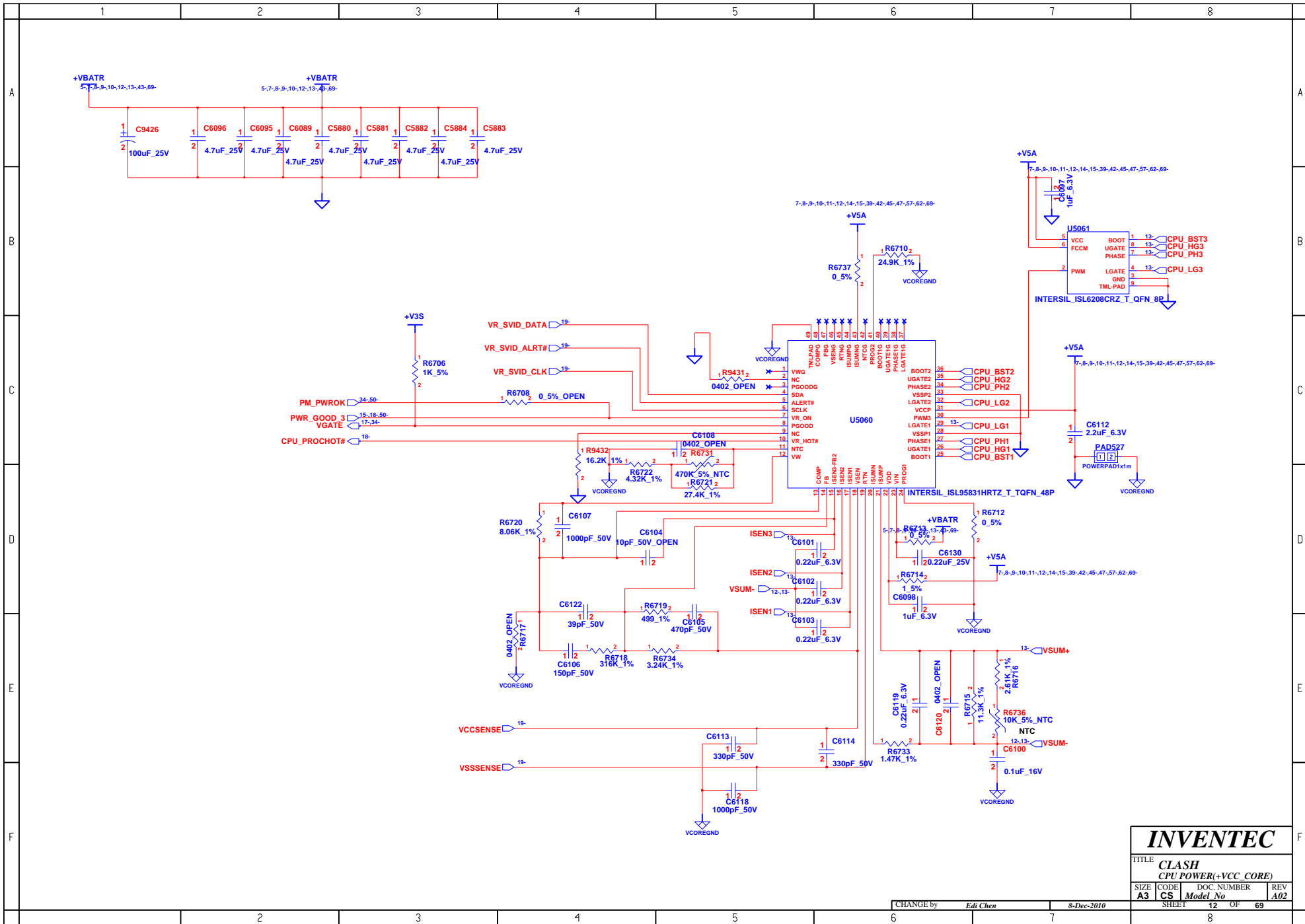

<b>INVENTEC</b>			
TITLE <b>CLASH CPU POWER(+VCC_CORE)</b>			
SIZE <b>A3</b>	CODE <b>CS</b>	DOC NUMBER <i>Model No</i>	REV <b>A02</b>
CHANGE by <i>Edi Chen</i>		8-Dec-2010	
SHEET <b>12</b>		OF <b>69</b>	

<http://sualaptop365.edu.vn>

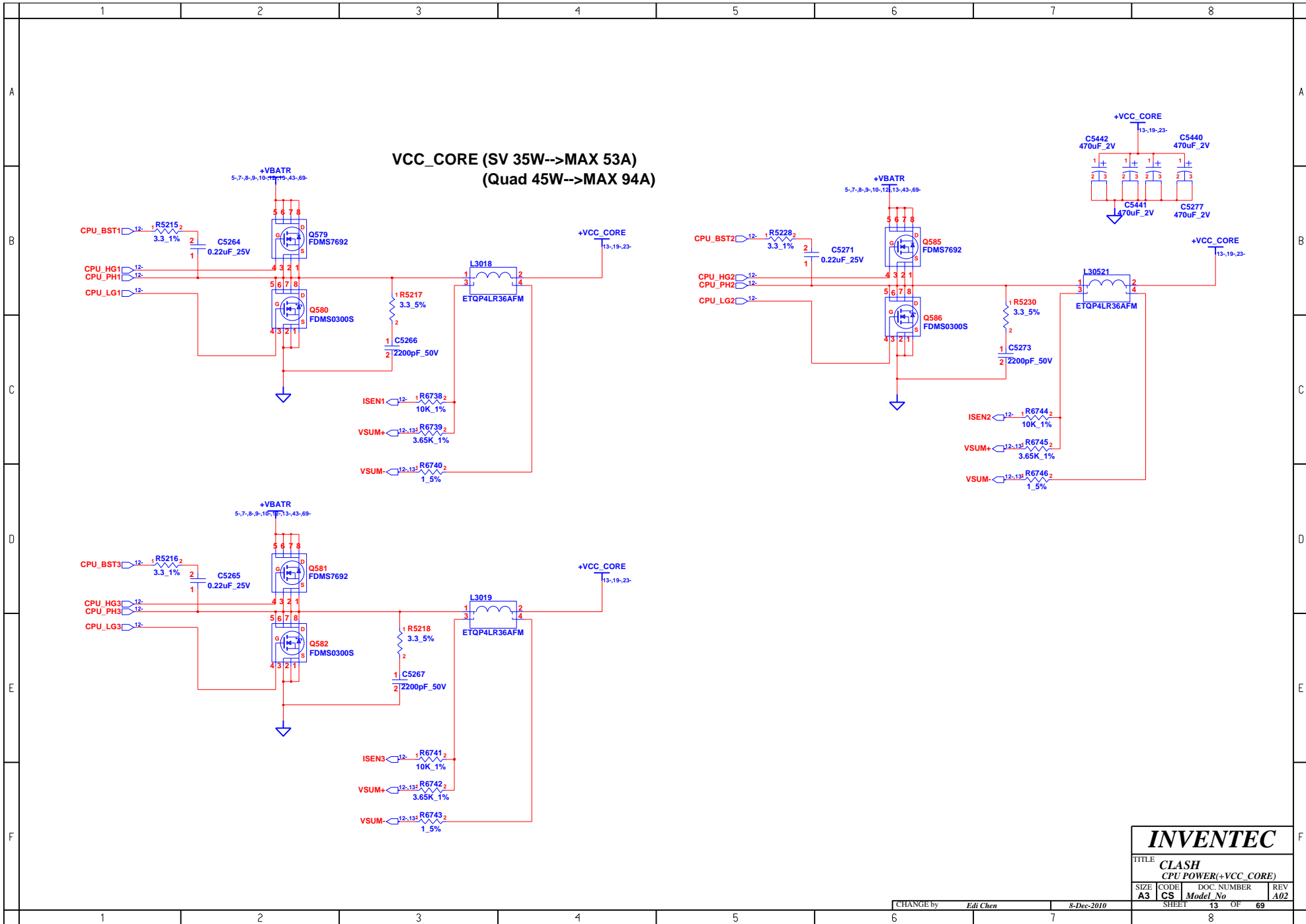

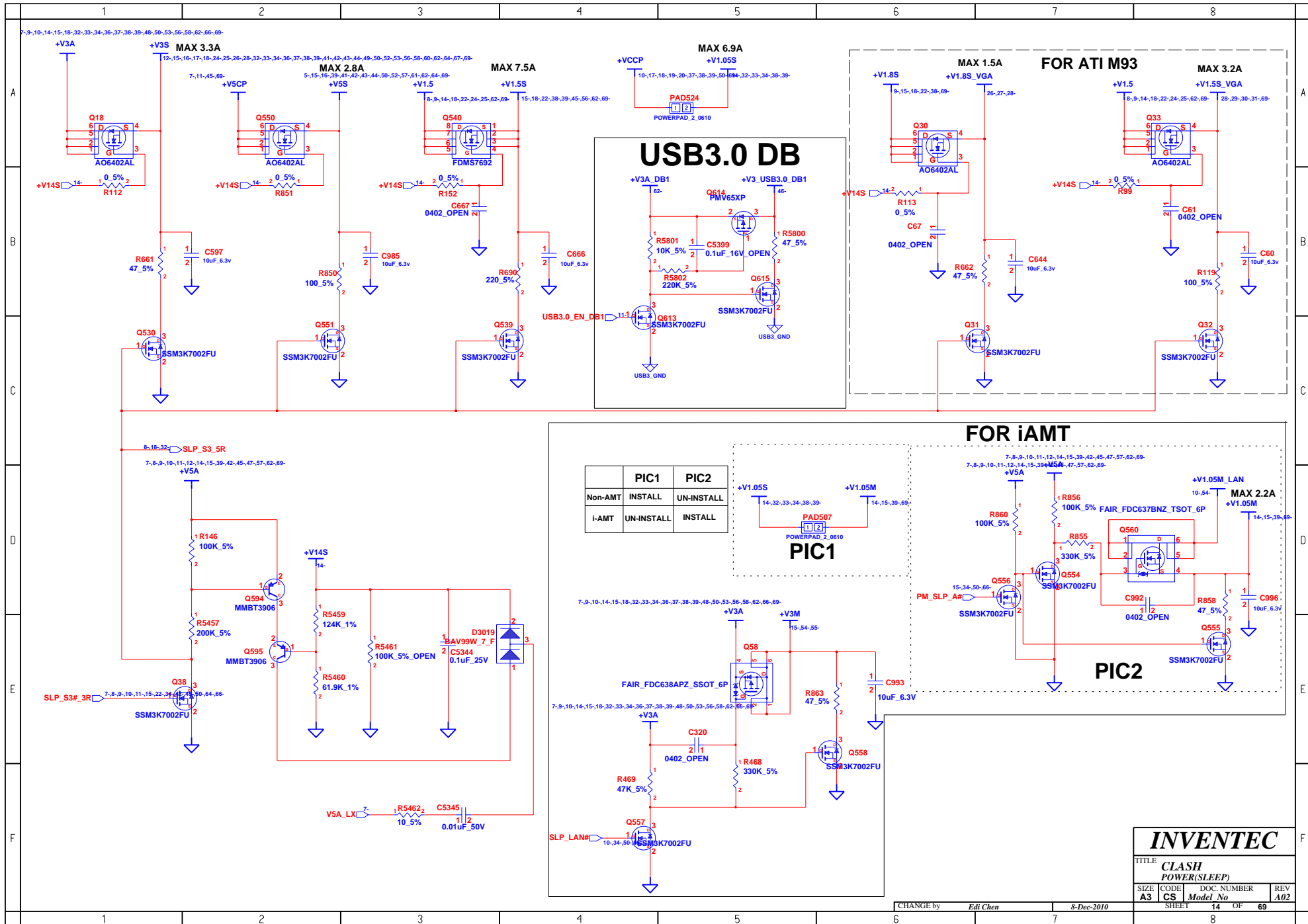

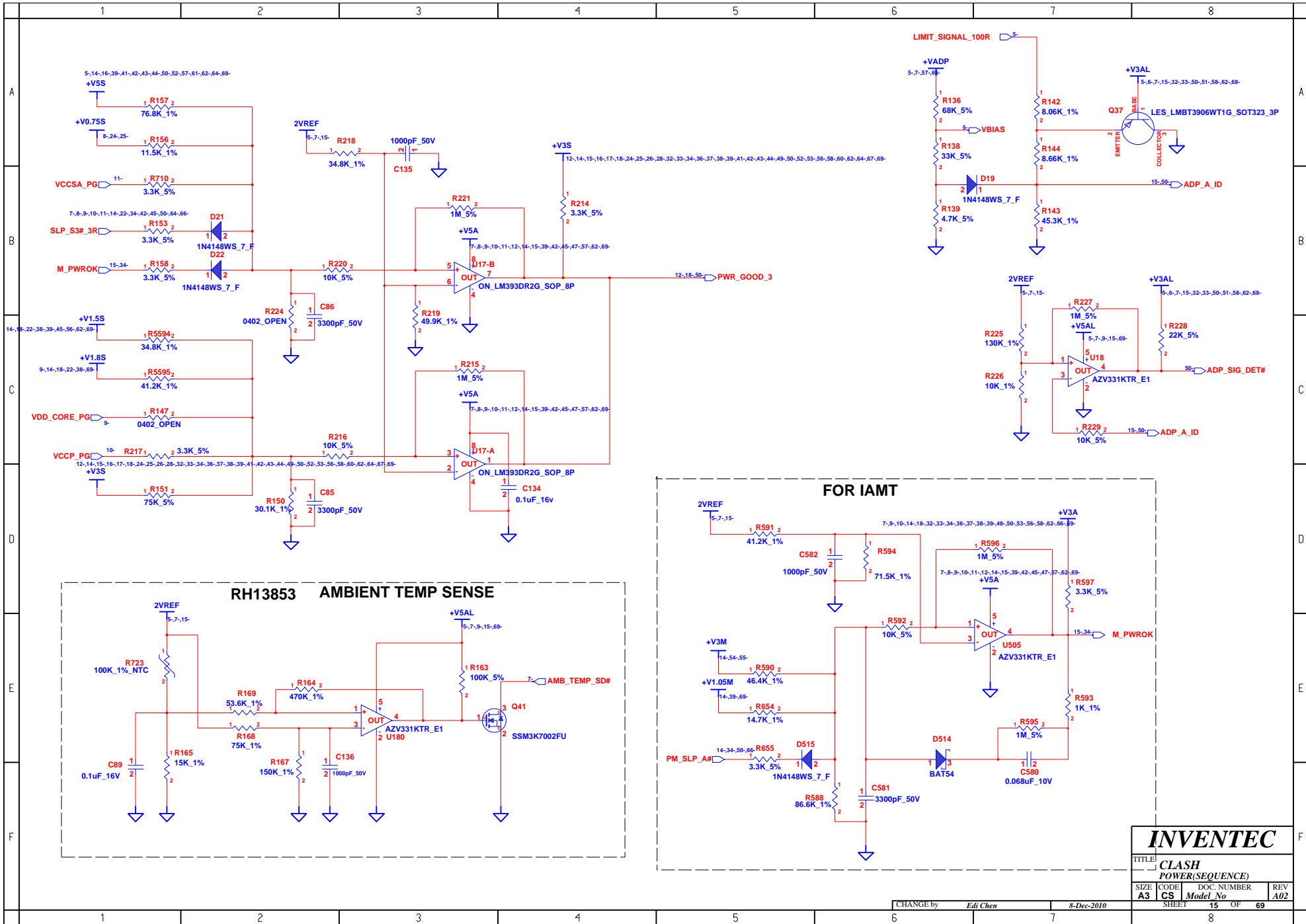

<http://sualaptop365.edu.vn>

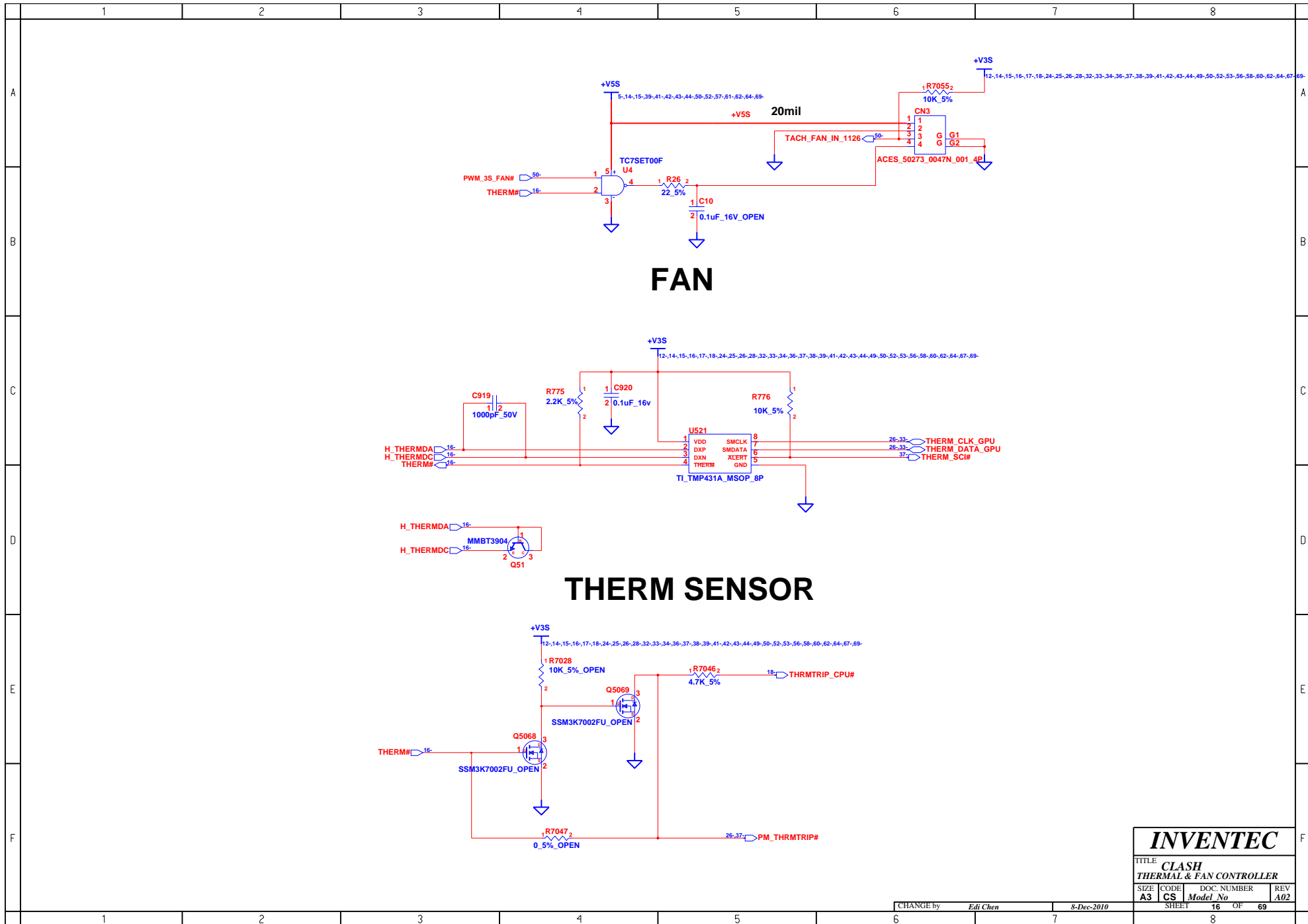

**INVENTEC**

TITLE <b>CLASH</b>			
THERMAL & FAN CONTROLLER			
SIZE <b>A3</b>	CODE <b>CS</b>	DOC NUMBER <b>Model No</b>	REV <b>A02</b>
CHANGE by <i>Edi Chen</i>		8-Dec-2010	SHEET <b>16</b> OF <b>69</b>



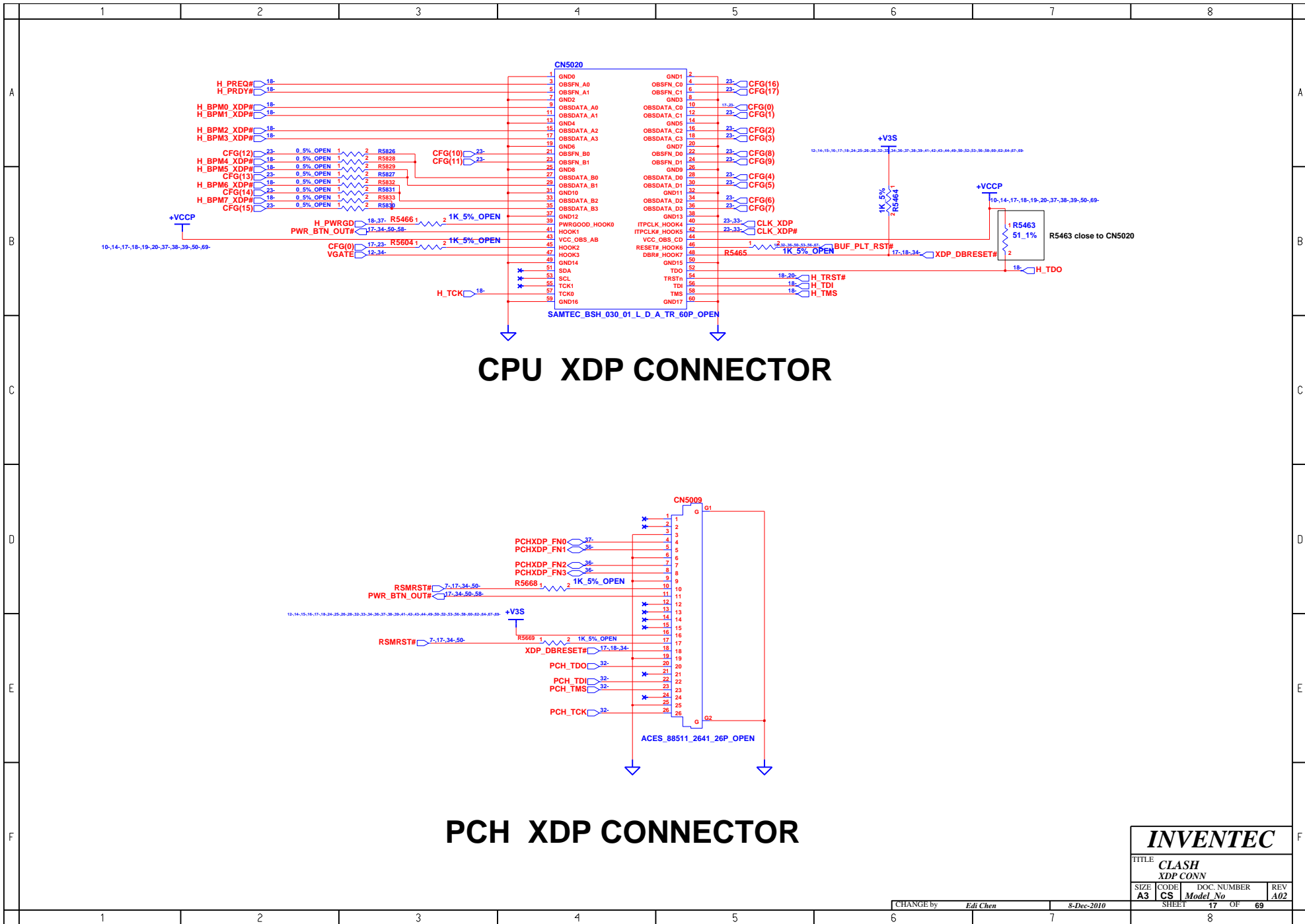

<b>INVENTEC</b>			
TITLE <b>CLASH XDP CONN</b>			
SIZE <b>A3</b>	CODE <b>CS</b>	DOC. NUMBER <b>Model No</b>	REV <b>A02</b>
CHANGE by <i>Edi Chen</i>		8-Dec-2010	
SHEET <b>17</b>		OF <b>69</b>	

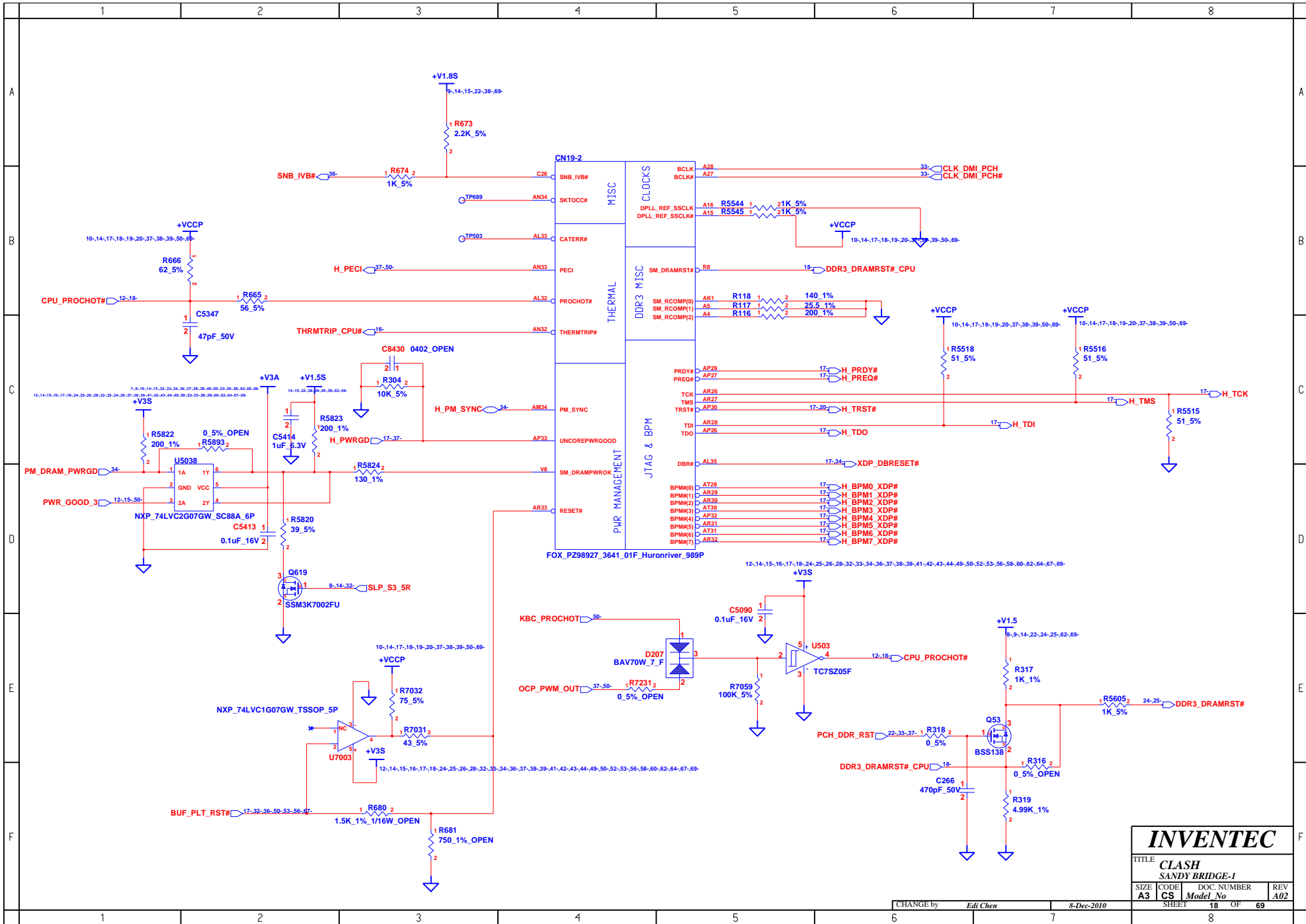

<b>INVENTEC</b>			
TITLE CLASH SANDY BRIDGE-1			
SIZE A3	CODE CS	DOC NUMBER Model No	REV A02
CHANGE by Edi Chen		8-Dec-2010	
SHEET 18		OF 69	

<http://sualaptop365.edu.vn>

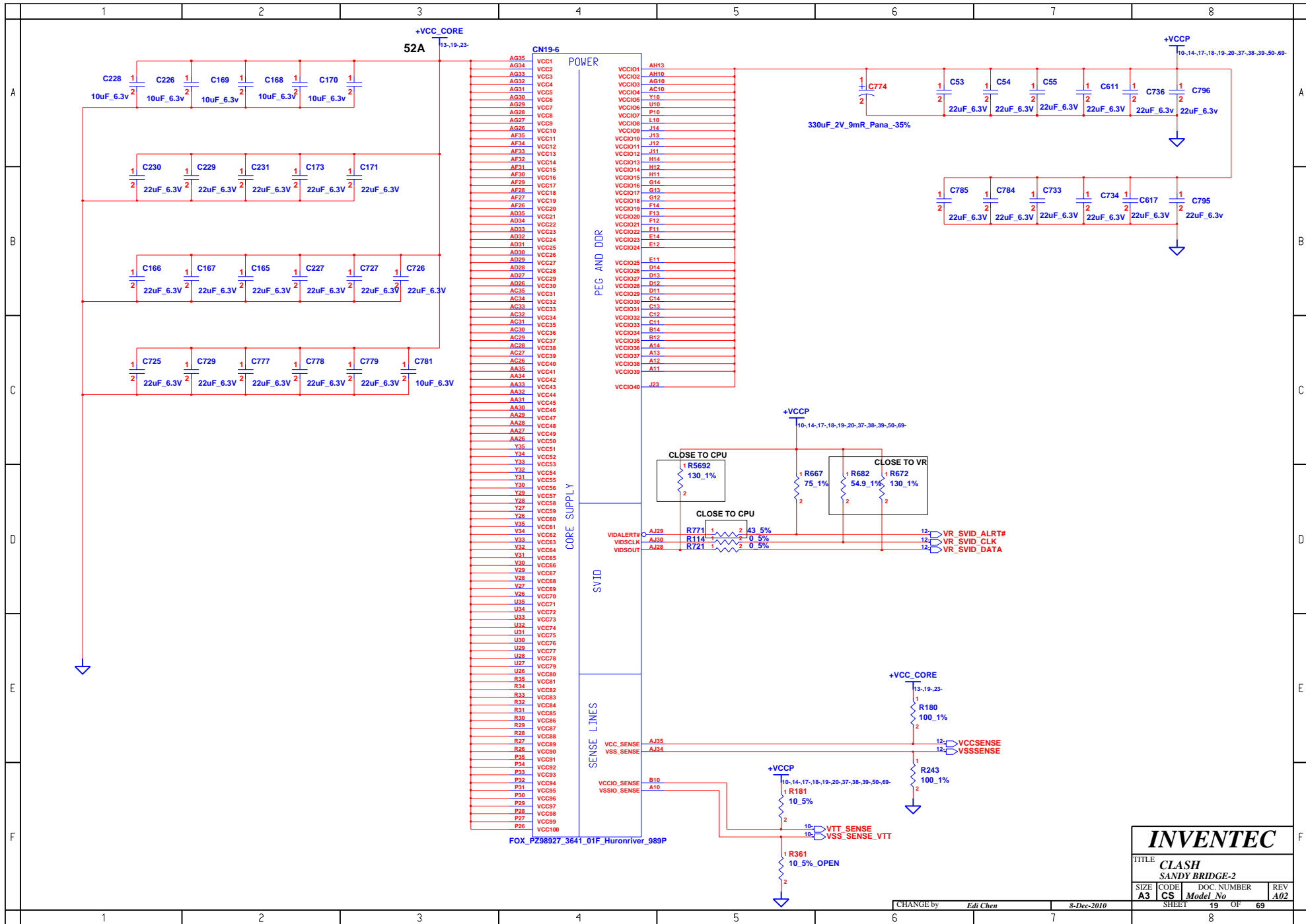

<b>INVENTEC</b>			
TITLE CLASH SANDY BRIDGE-2			
SIZE A3	CODE CS	DOC NUMBER Model No	REV A02
CHANGE by Edi Chen		8-Dec-2010	
SHEET 19		OF 69	

<http://sualaptop365.edu.vn>

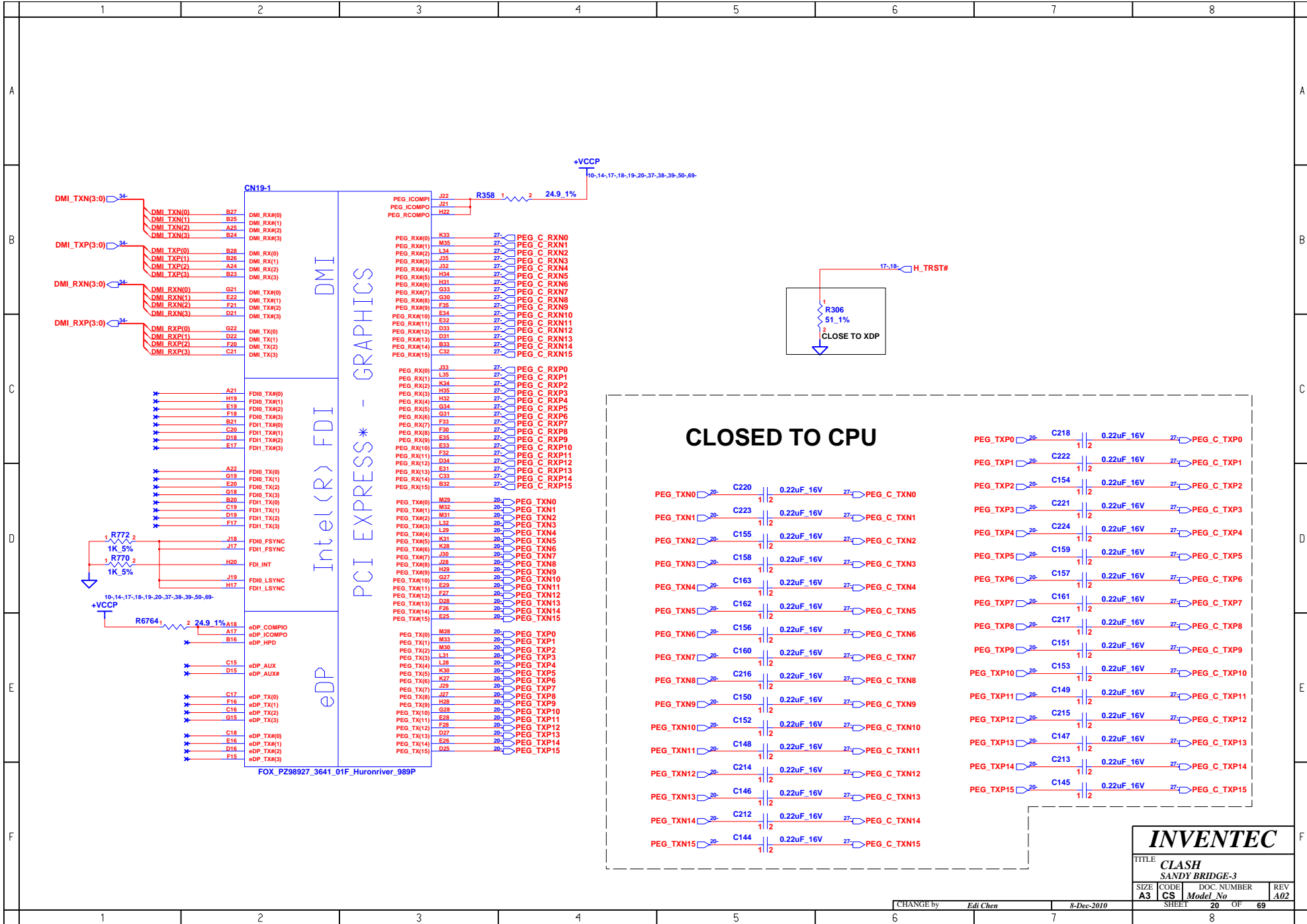

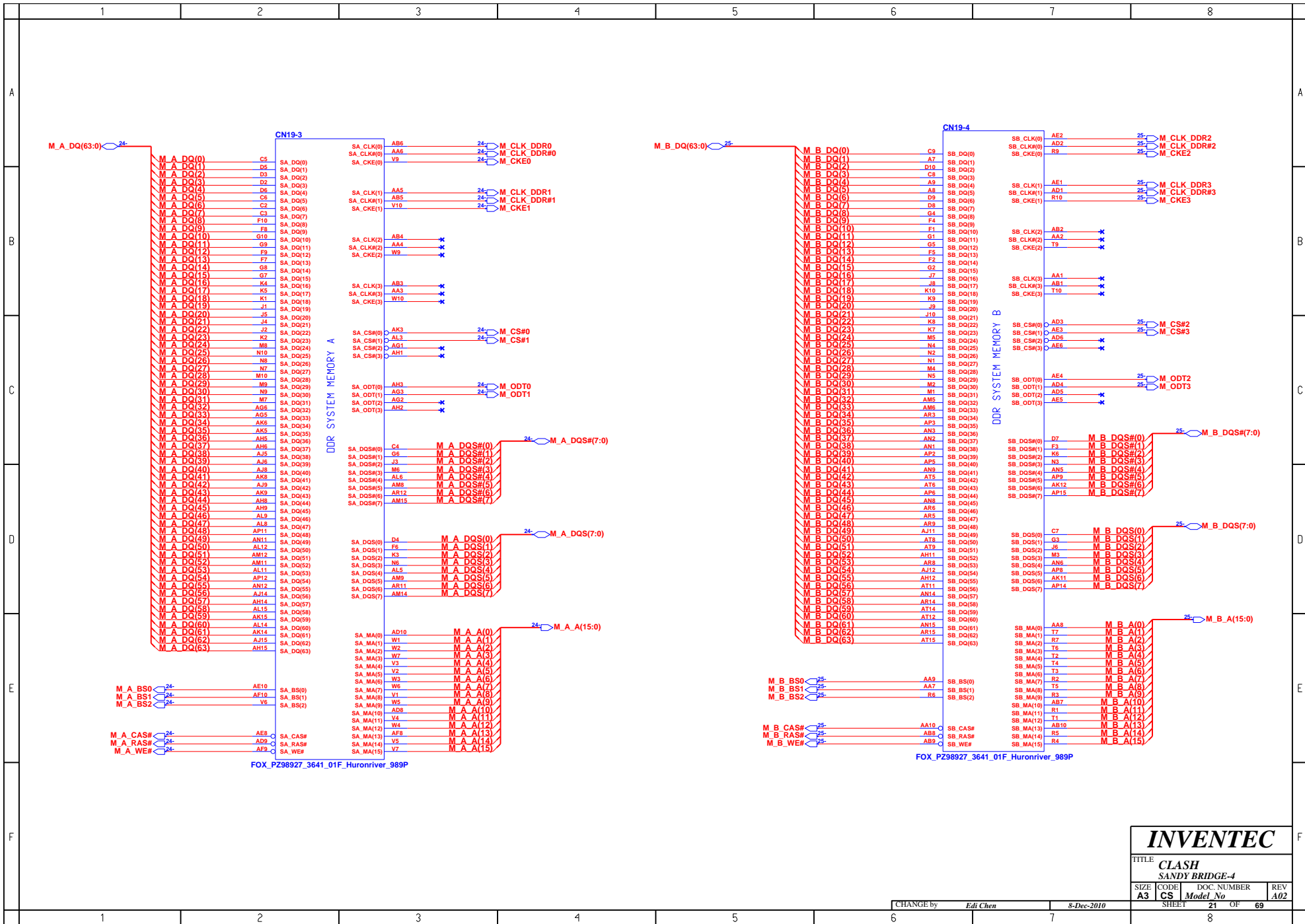

<b>INVENTEC</b>			
TITLE CLASH SANDY BRIDGE-4			
SIZE A3	CODE CS	DOC. NUMBER Model_No	REV A02
CHANGE by Edi Chen		8-Dec-2010	
SHEET 21		OF 69	

<http://sualaptop365.edu.vn>

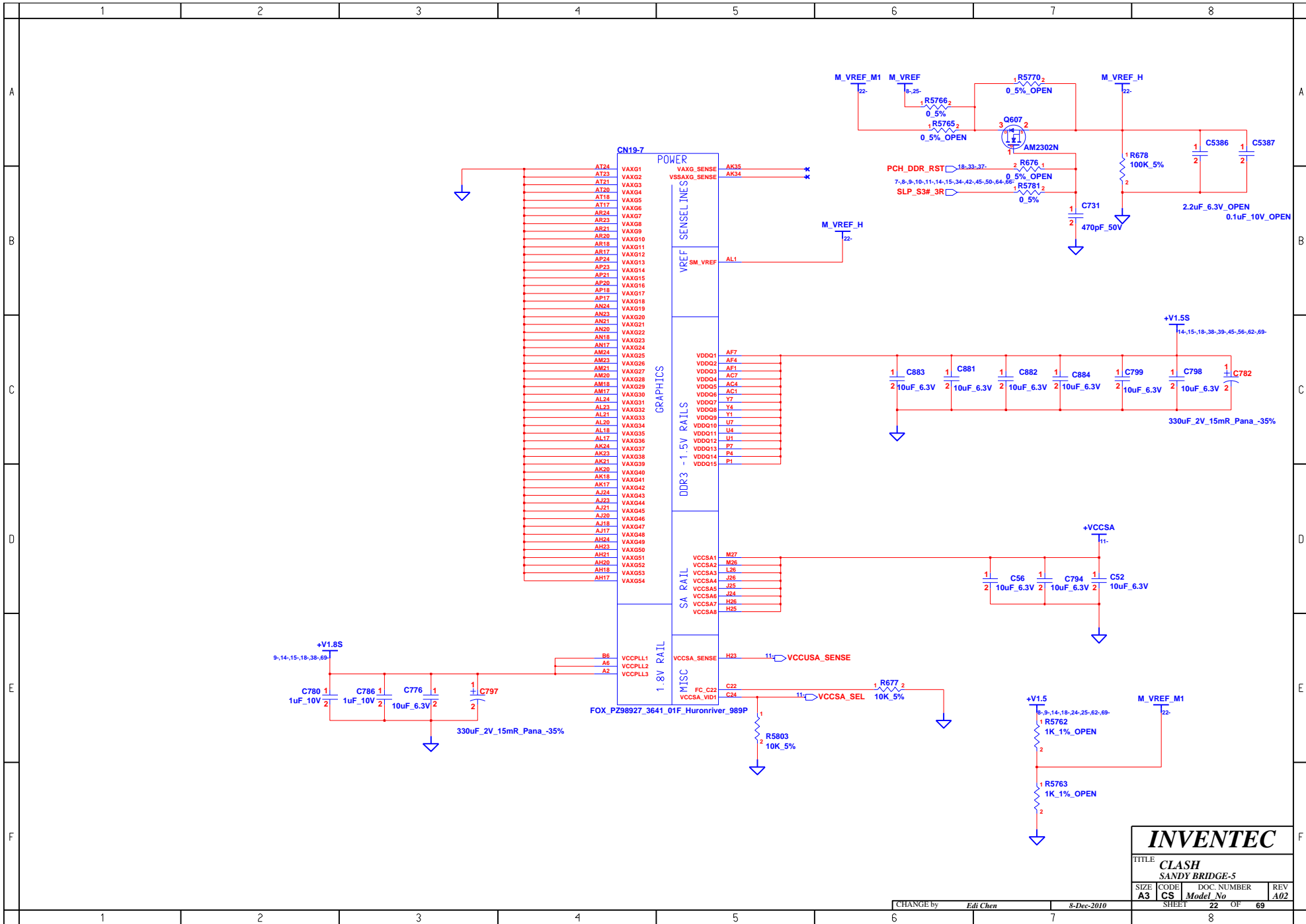

**INVENTEC**

TITLE			CLASH		
CODE			SANDY BRIDGE-5		
SIZE	CODE	DOC. NUMBER	REV		
A3	CS	Model No	A02		
SHEET		22	OF		69

CHANGE by *Edi Chen* 8-Dec-2010

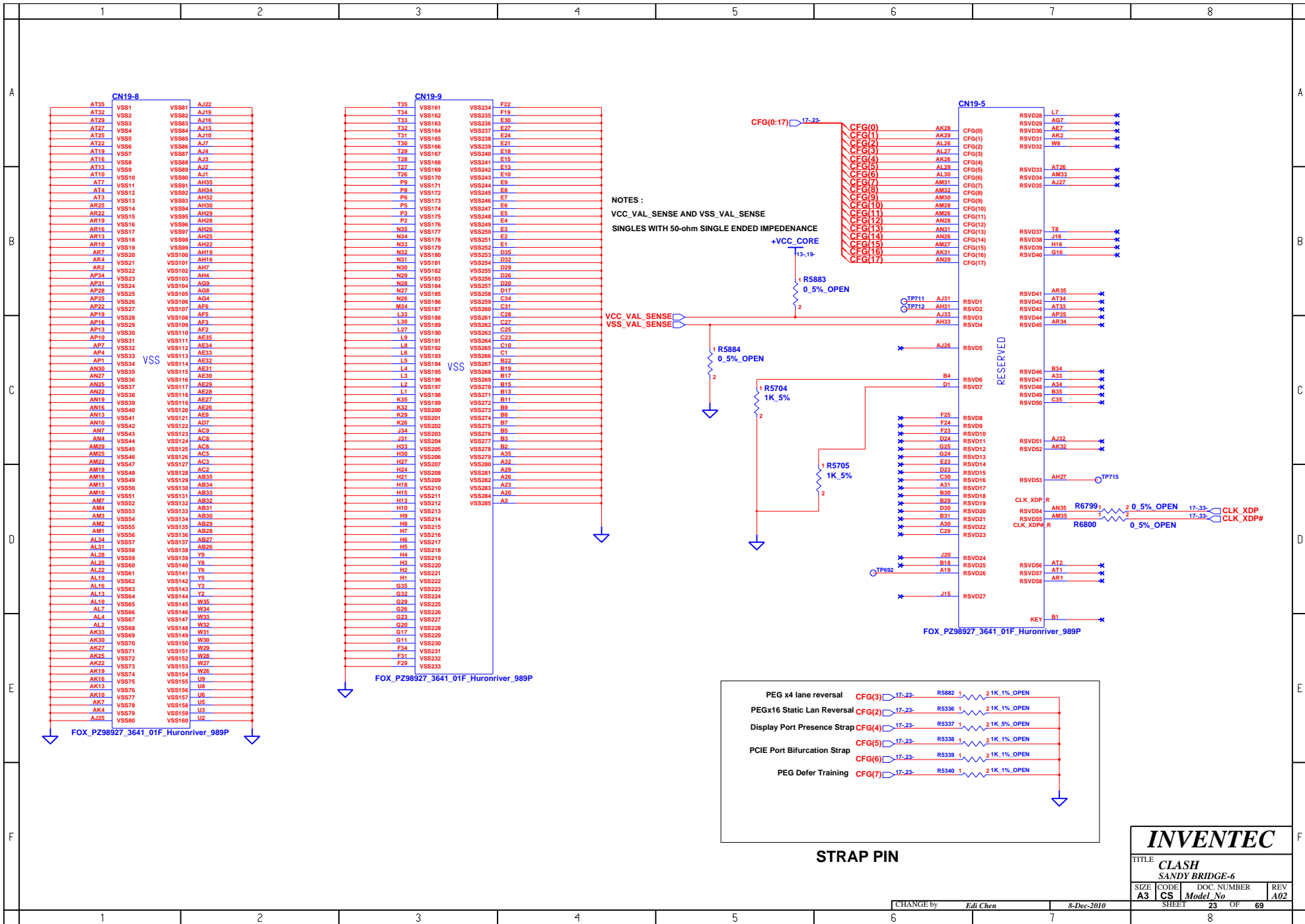

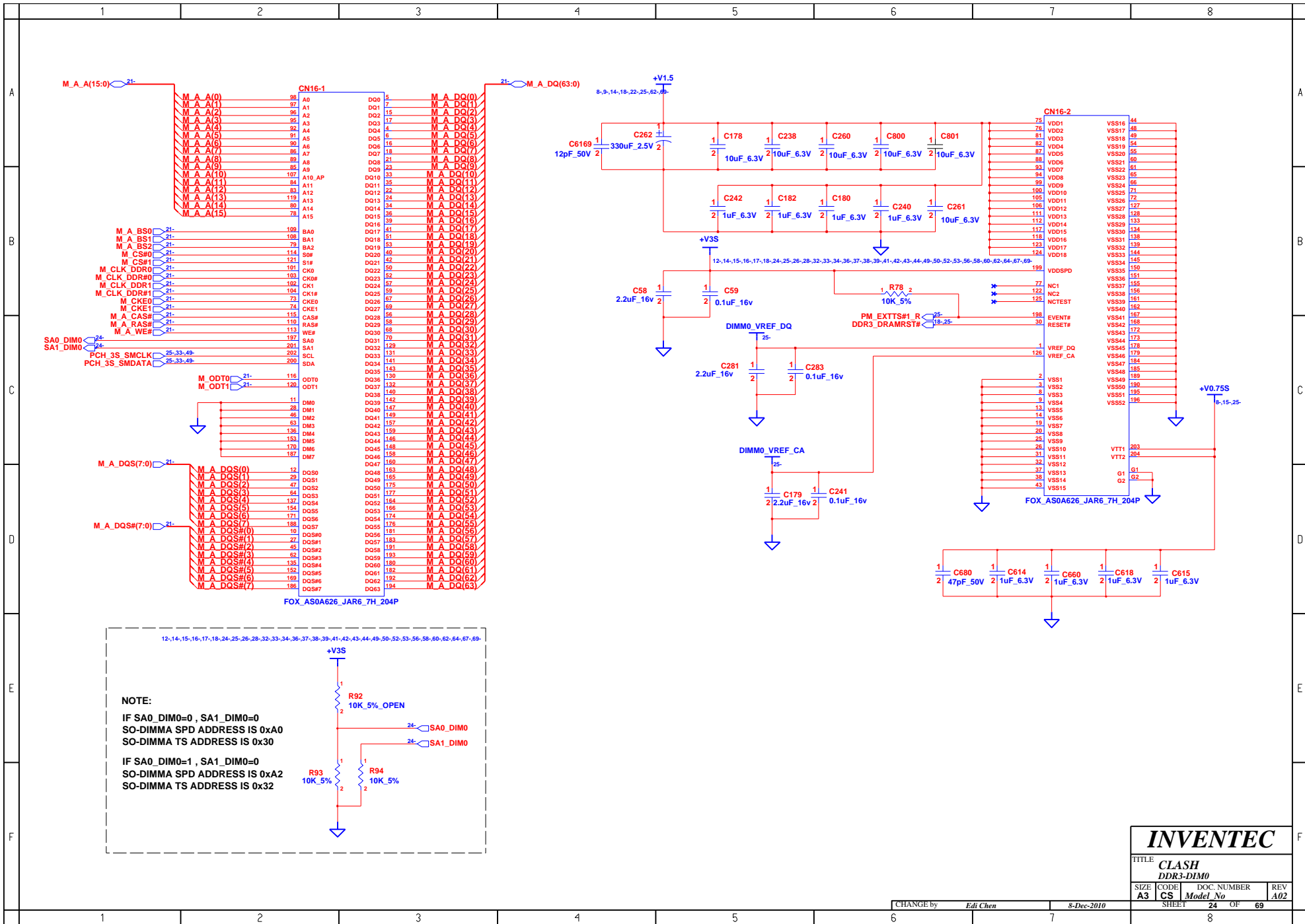

**NOTE:**

IF SA0\_DIM0=0, SA1\_DIM0=0  
 SO-DIMMA SPD ADDRESS IS 0xA0  
 SO-DIMMA TS ADDRESS IS 0x30

IF SA0\_DIM0=1, SA1\_DIM0=0  
 SO-DIMMA SPD ADDRESS IS 0xA2  
 SO-DIMMA TS ADDRESS IS 0x32

<b>INVENTEC</b>				
TITLE CLASH DDR3-DIM0				
SIZE A3	CODE CS	DOC. NUMBER Model No	REV A02	
CHANGE by Edi Chen		8-Dec-2010		
SHEET 24 OF 69			8	



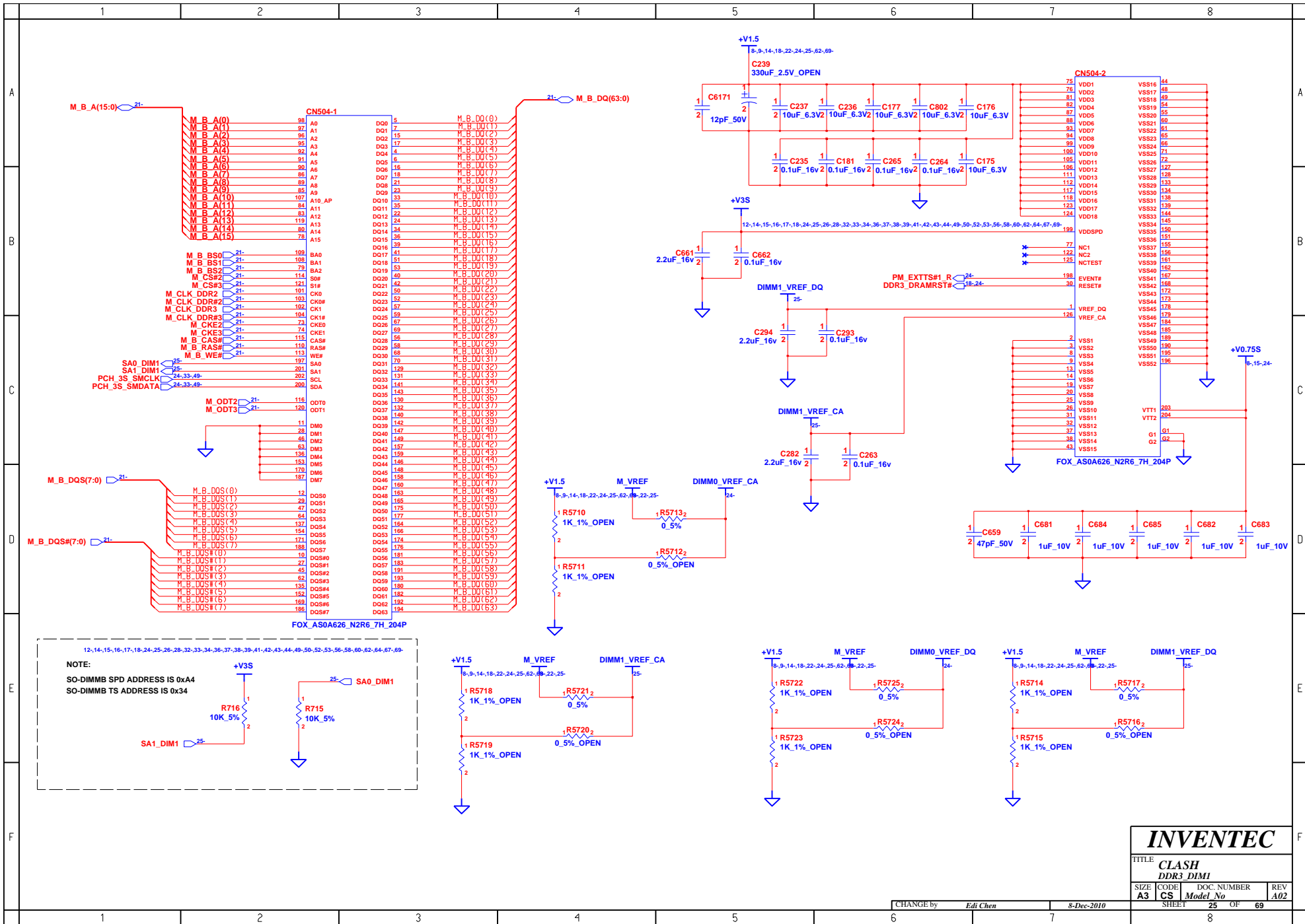

<http://sualaptop365.edu.vn>

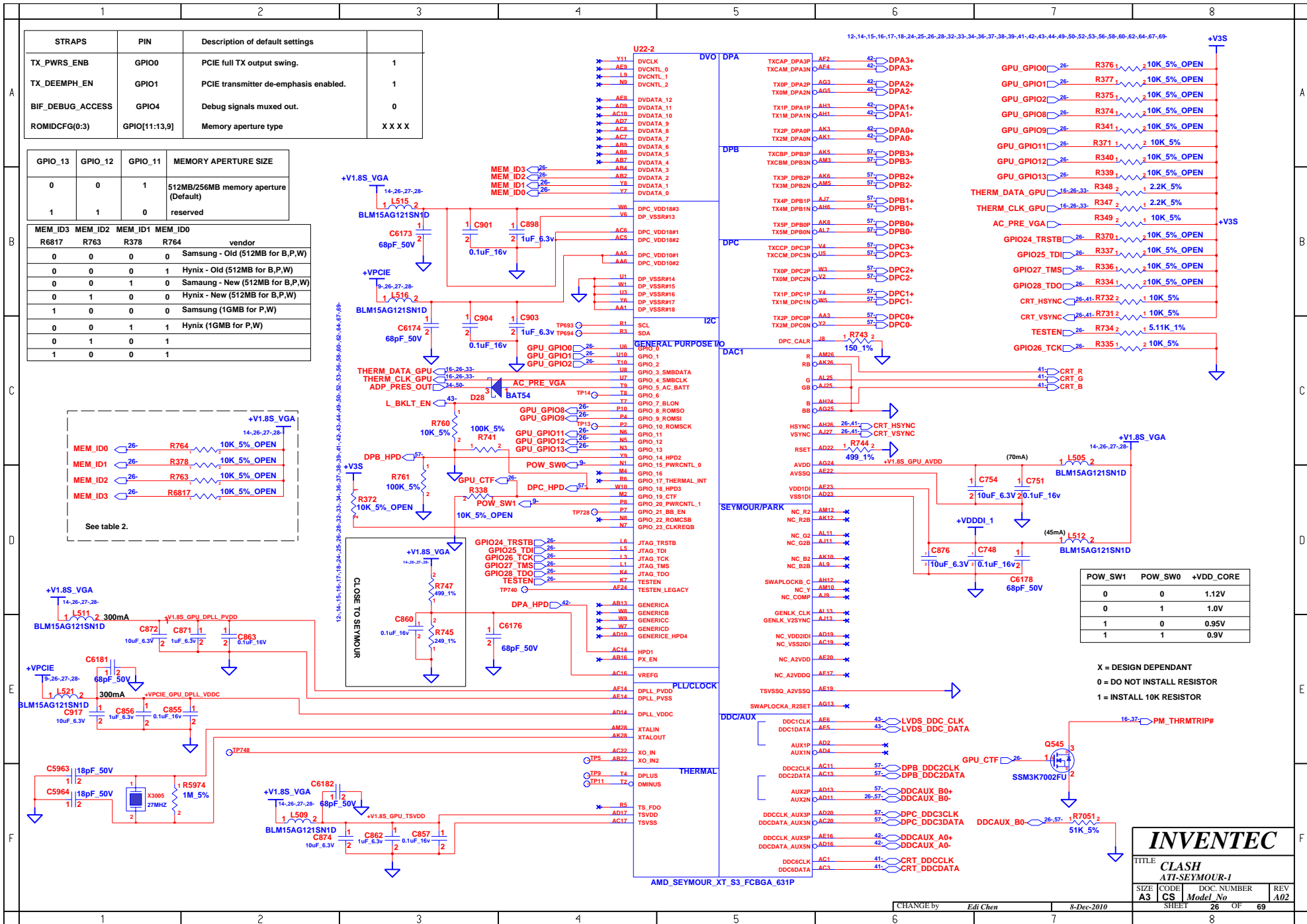

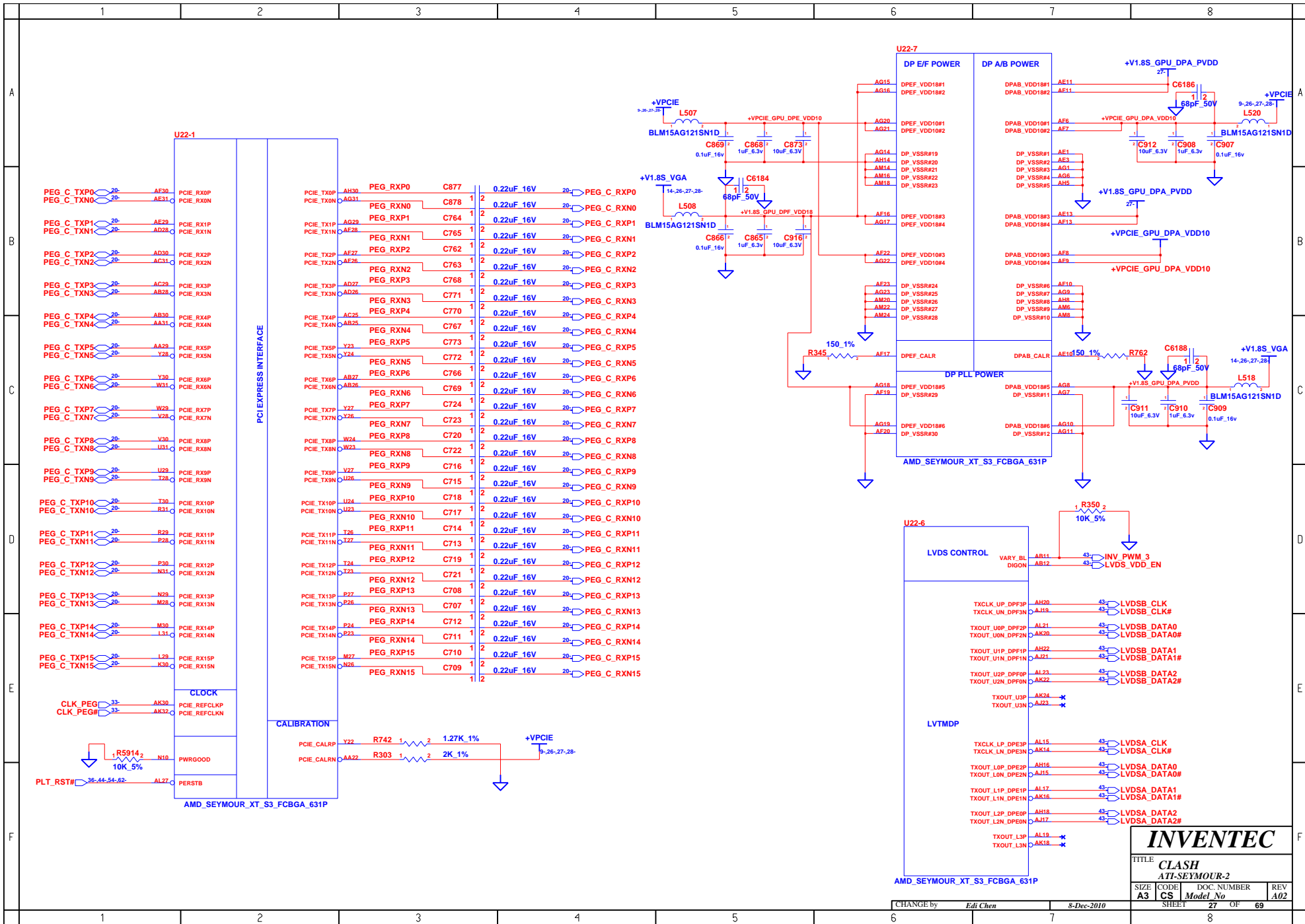

**INVENTEC**

TITLE  
**CLASH**  
**ATI-SEYMOUR-2**

SIZE	CODE	DOC NUMBER	REV
A3	CS	Model No	A02

SHEET 27 OF 69

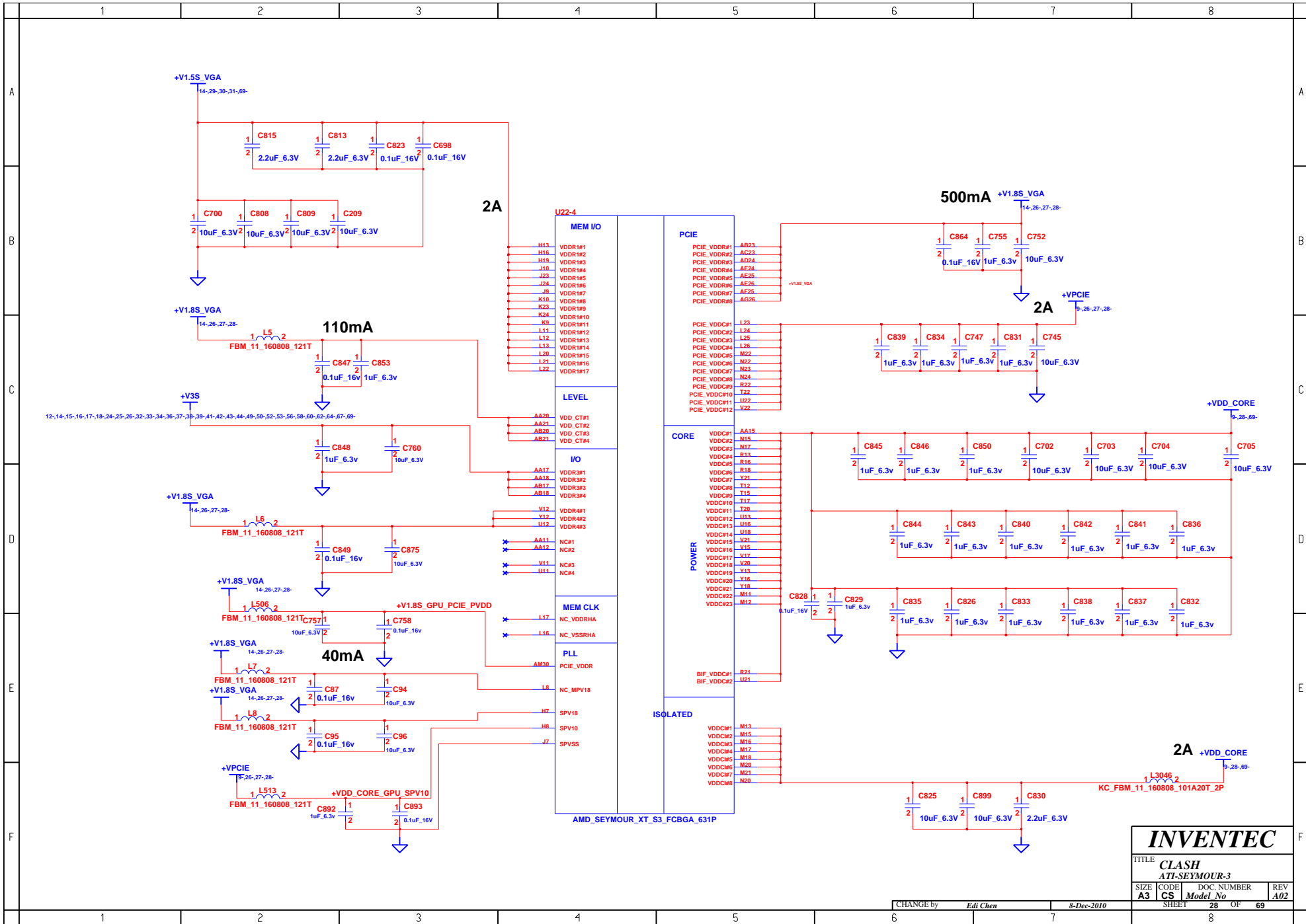

<b>INVENTEC</b>			
TITLE CLASH ATI-SEYMOUR-3			
SIZE A3	CODE CS	DOC NUMBER Model No	REV A02
CHANGE by Edi Chen		8-Dec-2010	
SHEET 28		OF 69	

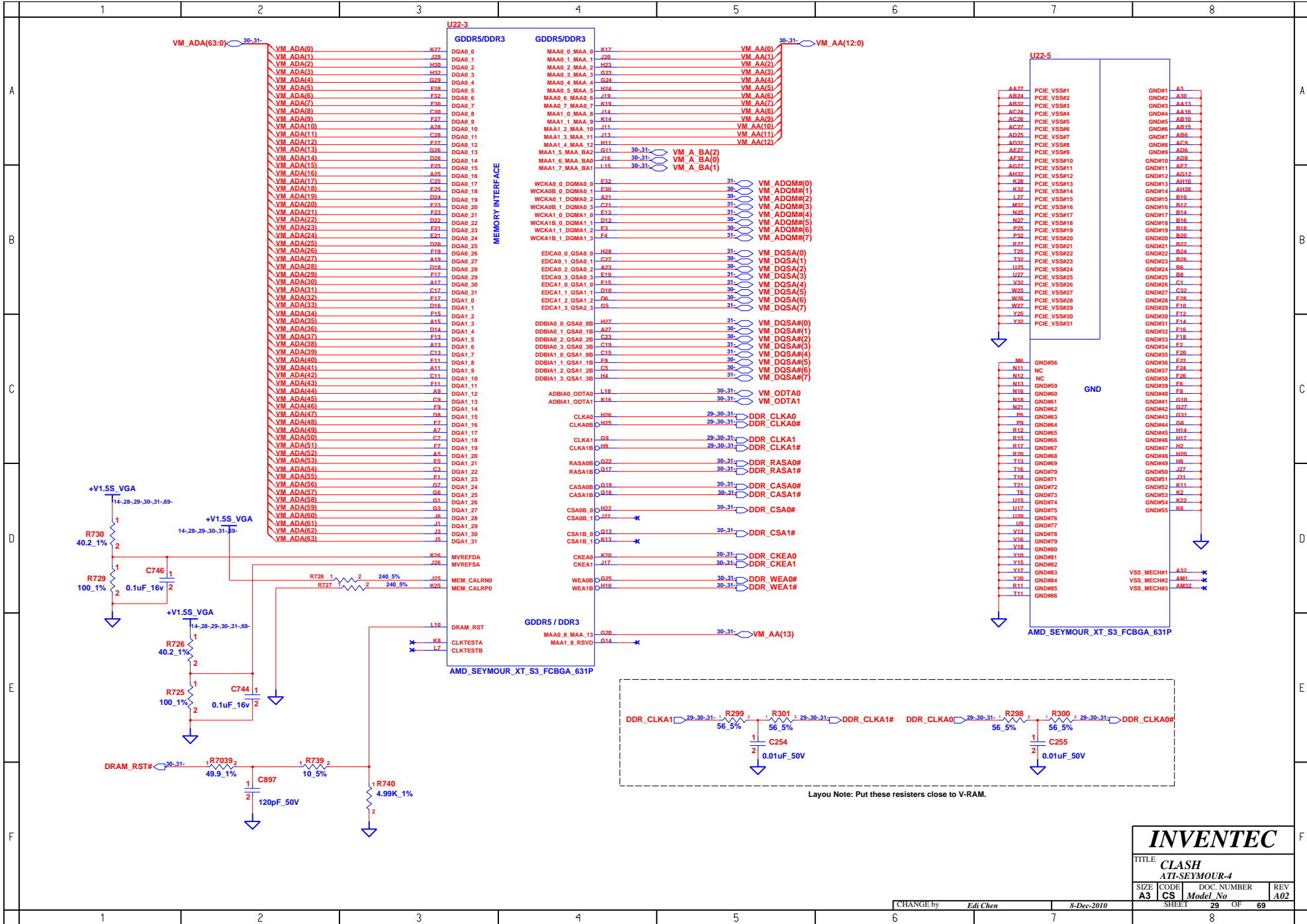

<http://sualaptop365.edu.vn>

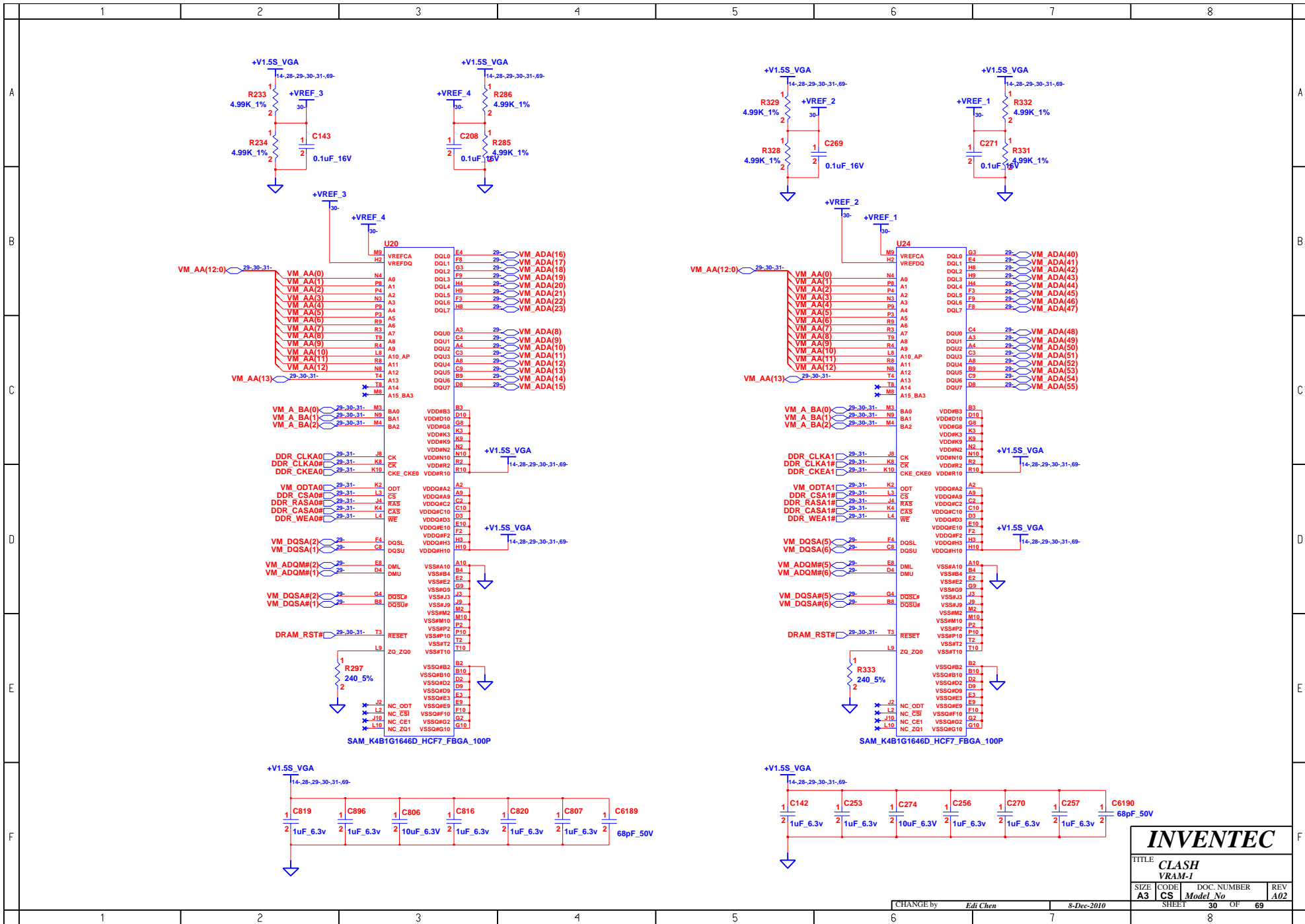

<b>INVENTEC</b>			
TITLE CLASH VRAM-1			
SIZE A3	CODE CS	DOC. NUMBER Model No	REV A02
CHANGE by Edi Chen		8-Dec-2010	
SHEET 30		OF 69	

<http://sualaptop365.edu.vn>

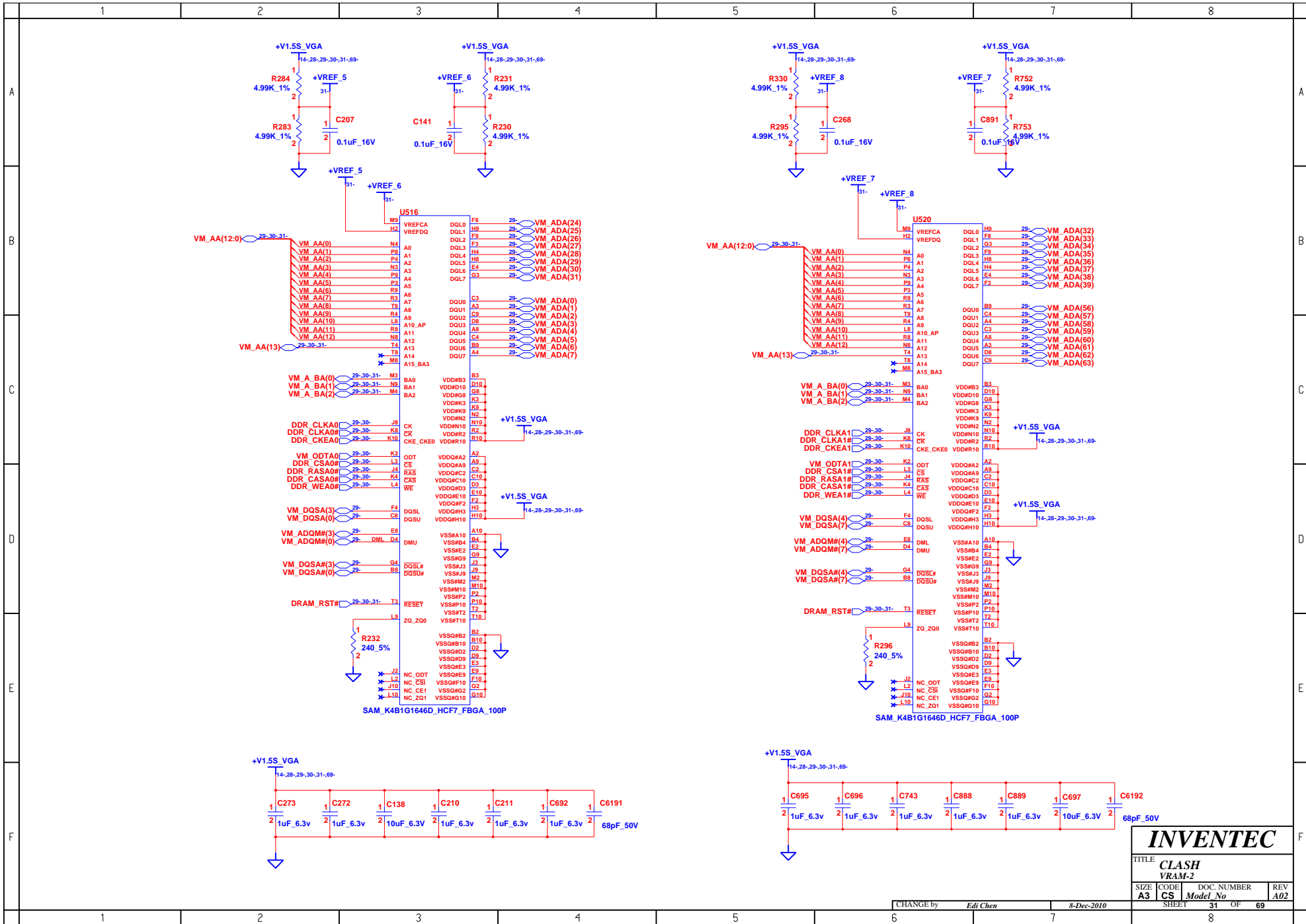

<b>INVENTEC</b>			
TITLE CLASH VRAM-2			
SIZE A3	CODE CS	DOC. NUMBER Model_No	REV A02
CHANGE by Edi Chen		8-Dec-2010	
SHEET 31		OF 69	

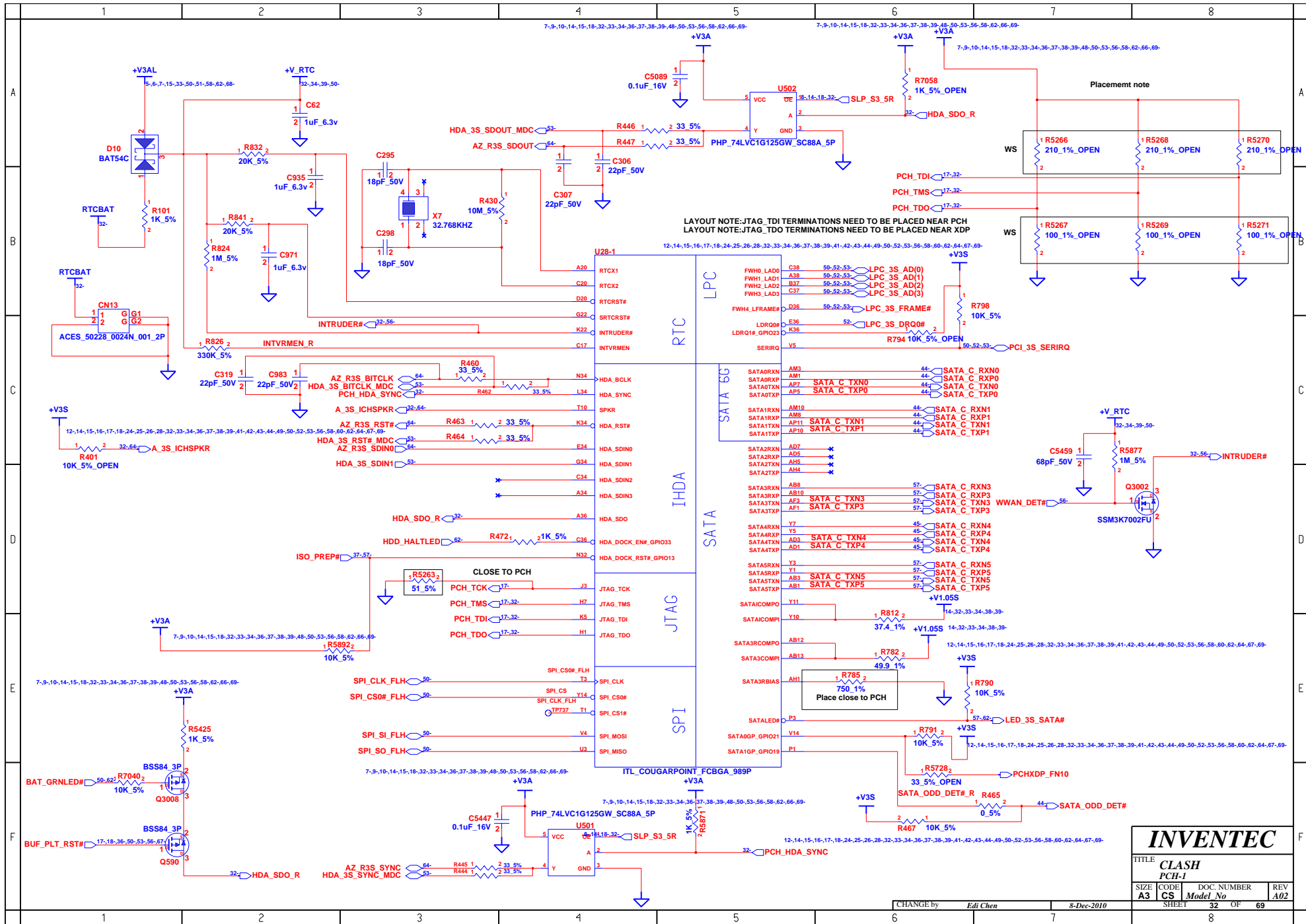



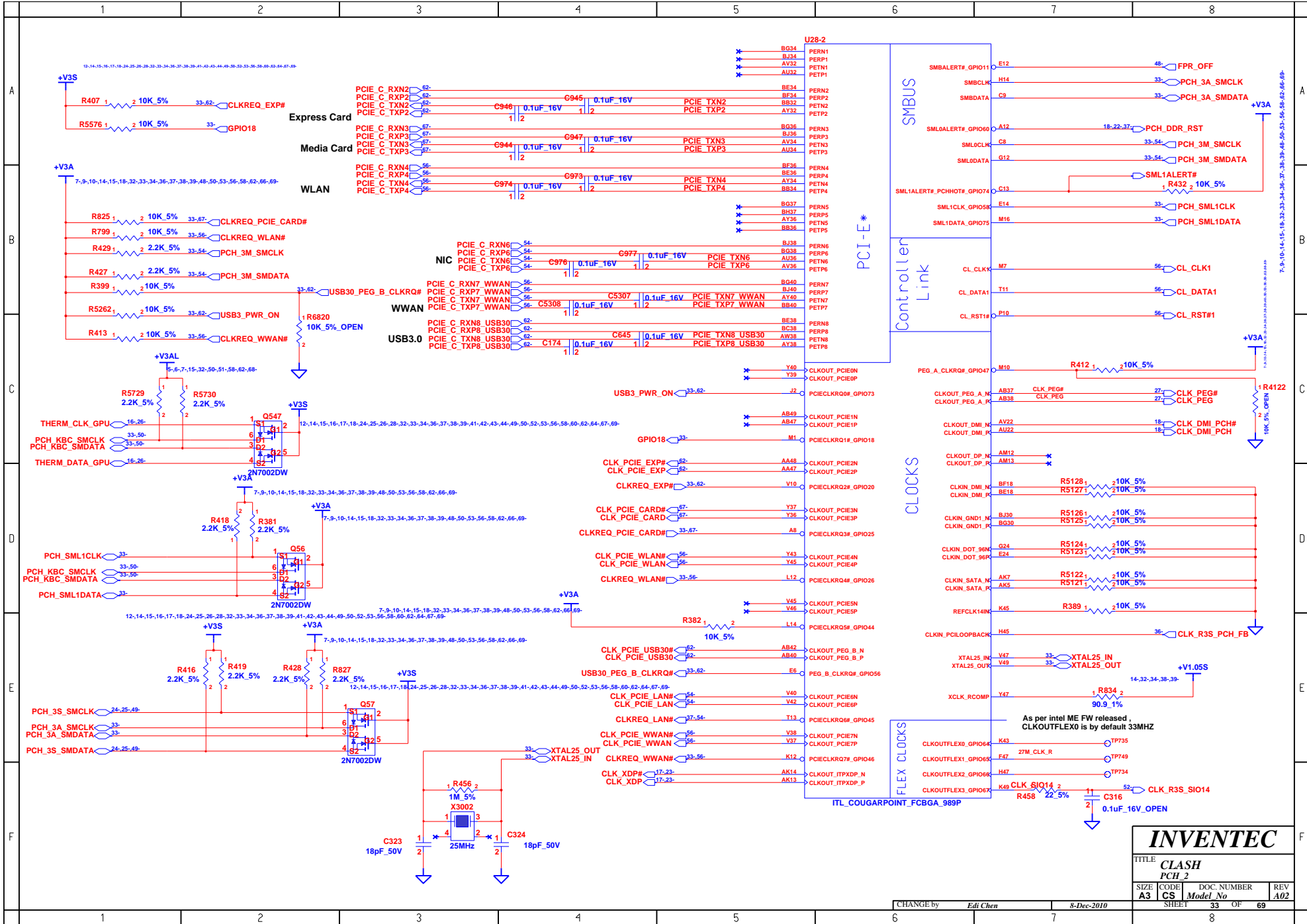

<b>INVENTEC</b>			
TITLE <b>CLASH PCH 2</b>			
SIZE <b>A3</b>	CODE <b>CS</b>	DOC. NUMBER <i>Model No</i>	REV <b>A02</b>
SHEET		OF	
33		69	

CHANGE by *Edi Chen* 8-Dec-2010

Note: 1.SLP\_SUS and SUSACK# are NC if DSW is not supported  
 2.DPWROK should connect to RSMRST# if DSW not supported  
 3.PCH\_DPWROK pull up to +V3S enables DSW support. No install R5261 to disable DSW

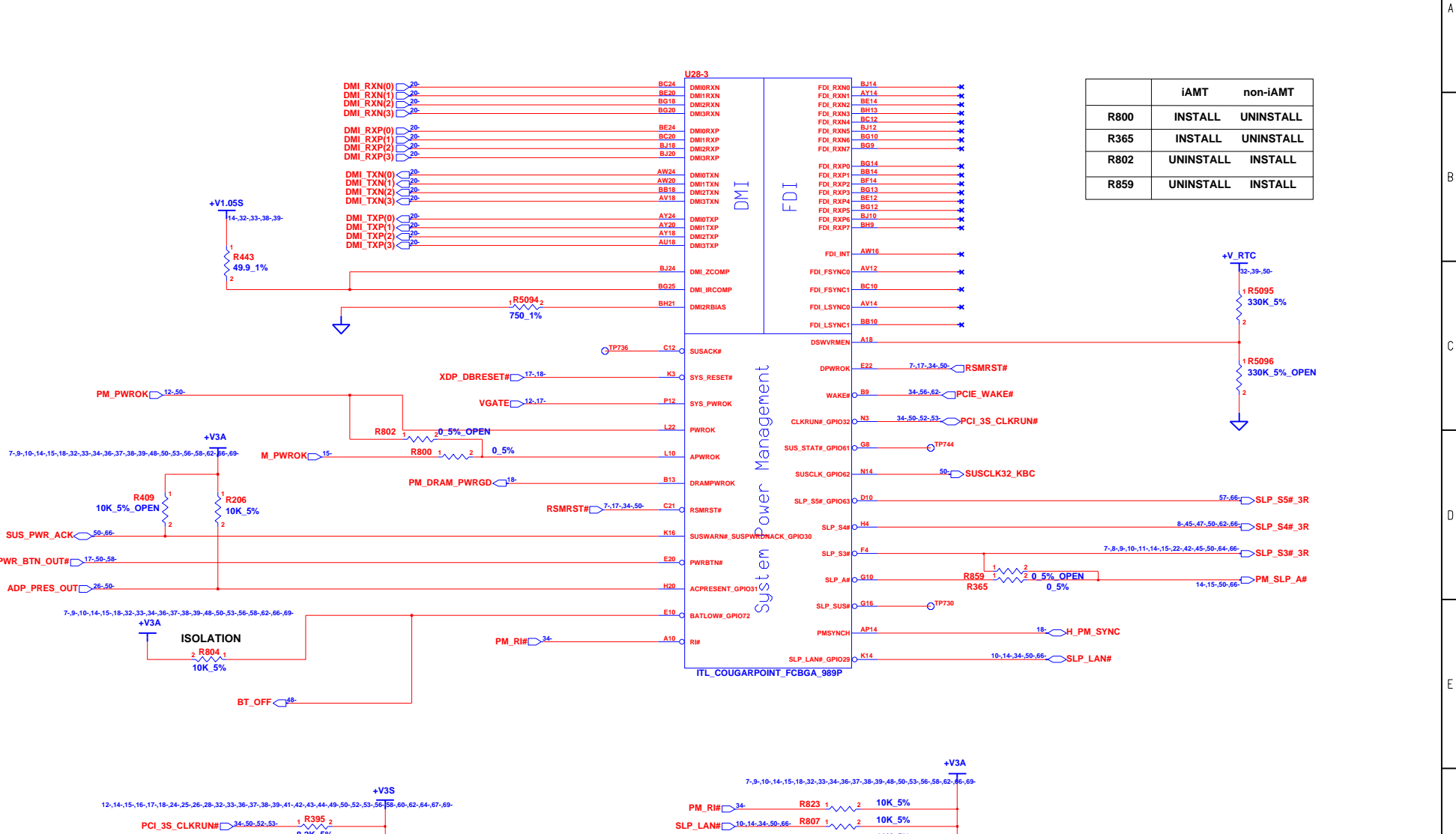

	iAMT	non-iAMT
R800	INSTALL	UNINSTALL
R365	INSTALL	UNINSTALL
R802	UNINSTALL	INSTALL
R859	UNINSTALL	INSTALL

System Power Management

<b>INVENTEC</b>			
TITLE CLASH PCH-3			
SIZE A3	CODE CS	DOC NUMBER Model No	REV A02
CHANGE by Edi Chen		8-Dec-2010	
SHEET 34		OF 69	

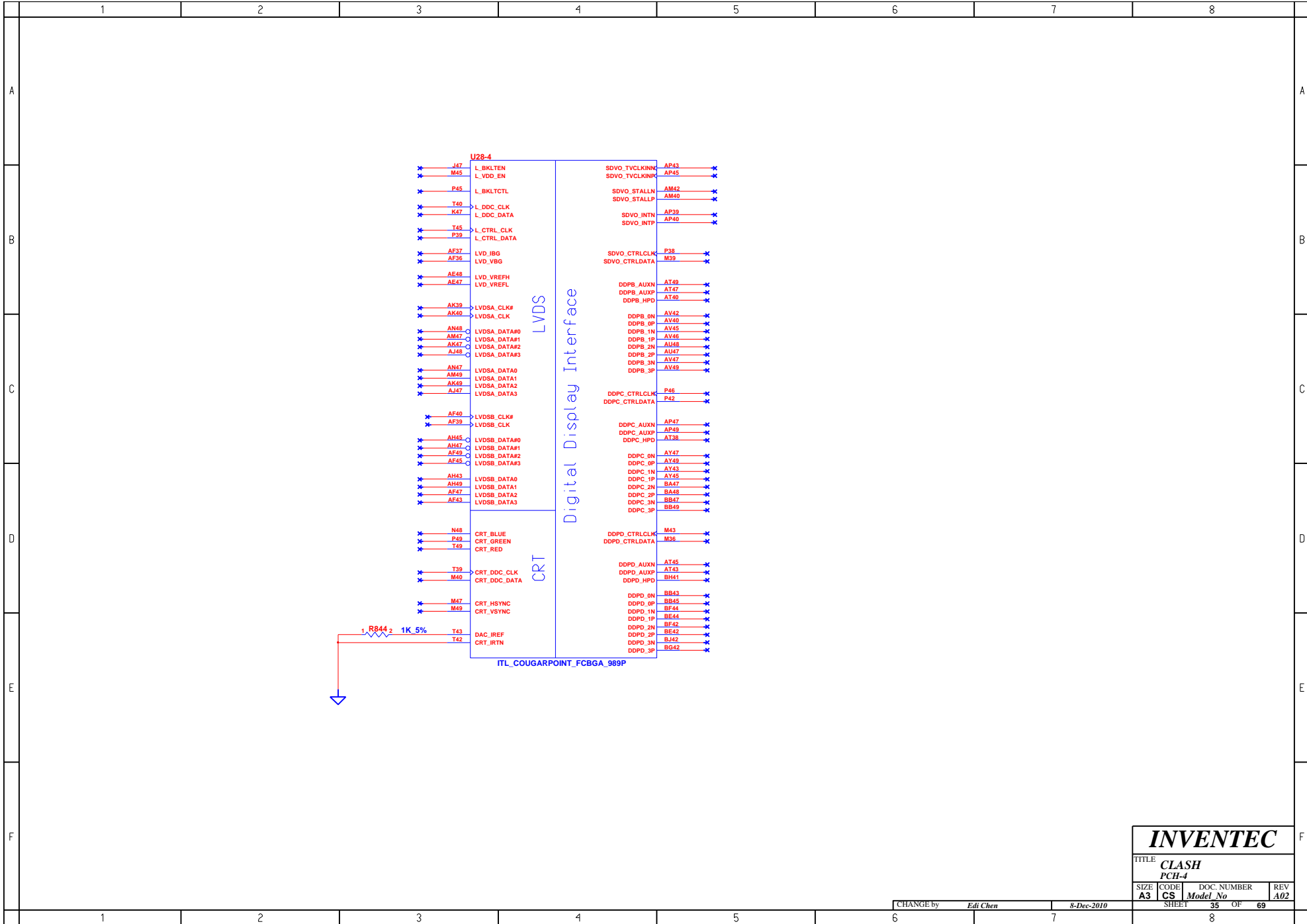

<b>INVENTEC</b>			
TITLE <b>CLASH</b>			
PCH-4			
SIZE <b>A3</b>	CODE <b>CS</b>	DOC. NUMBER <b>Model No</b>	REV <b>A02</b>
CHANGE by <i>Edi Chen</i>		8-Dec-2010	
SHEET <b>35</b>		OF <b>69</b>	

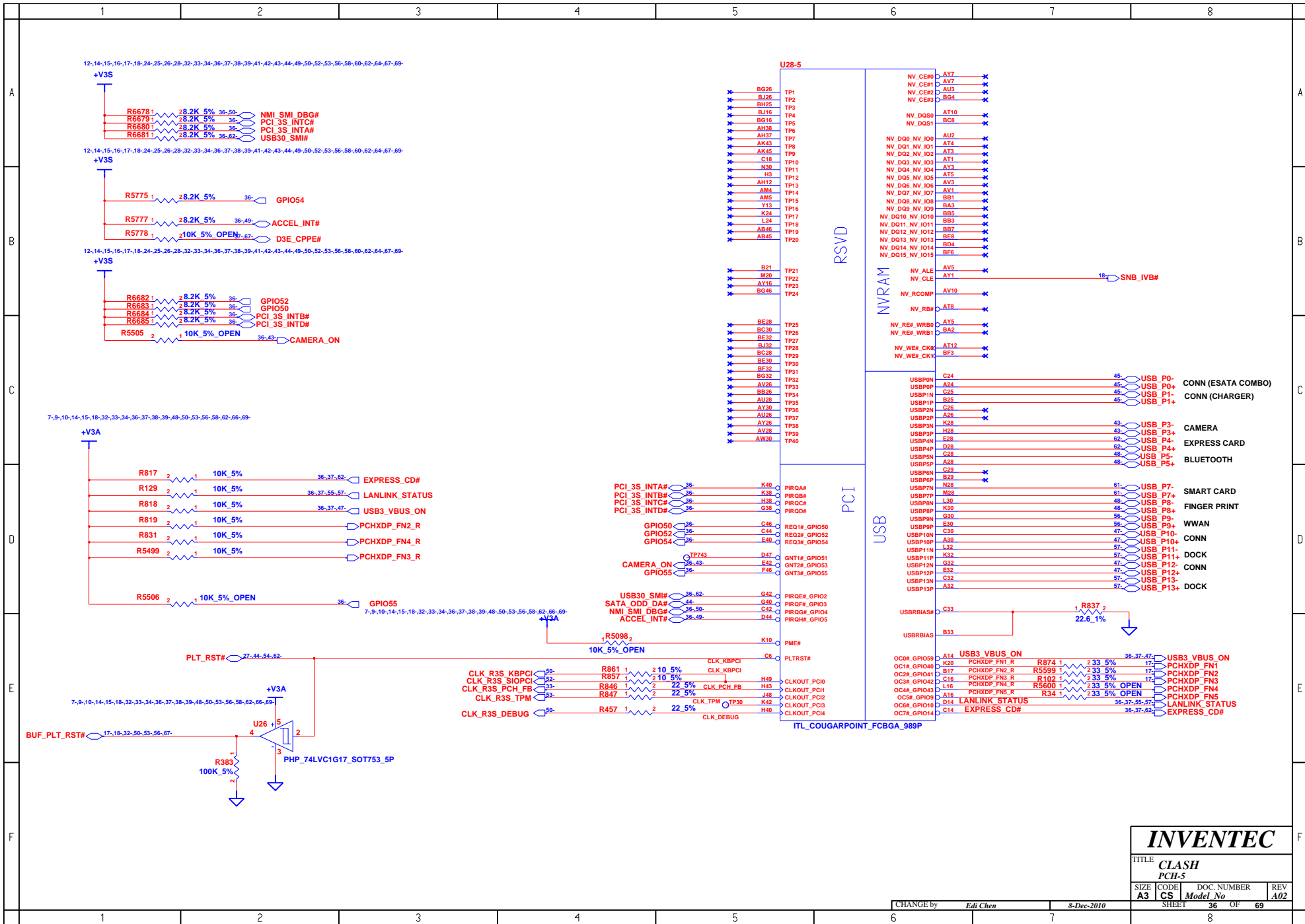

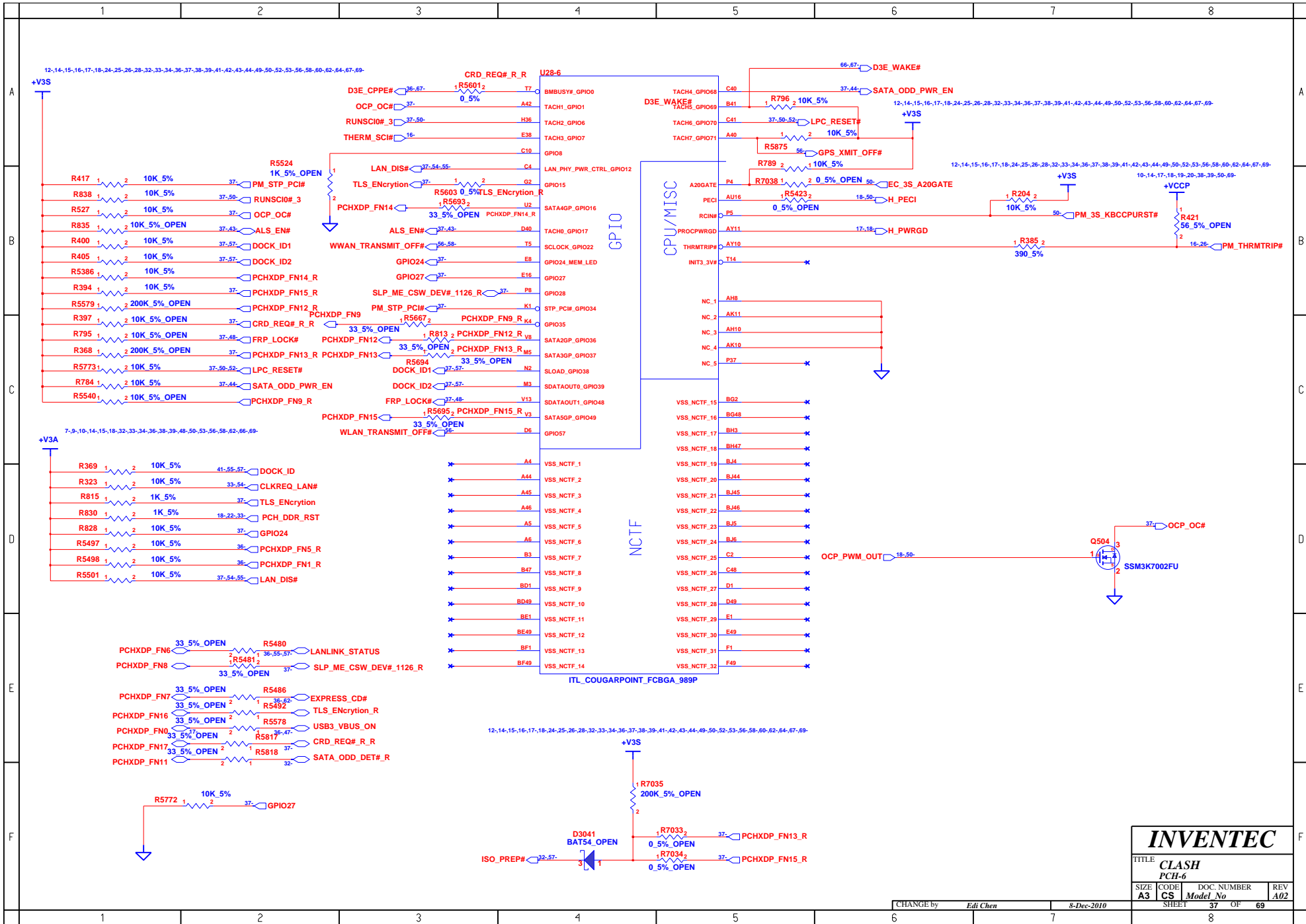

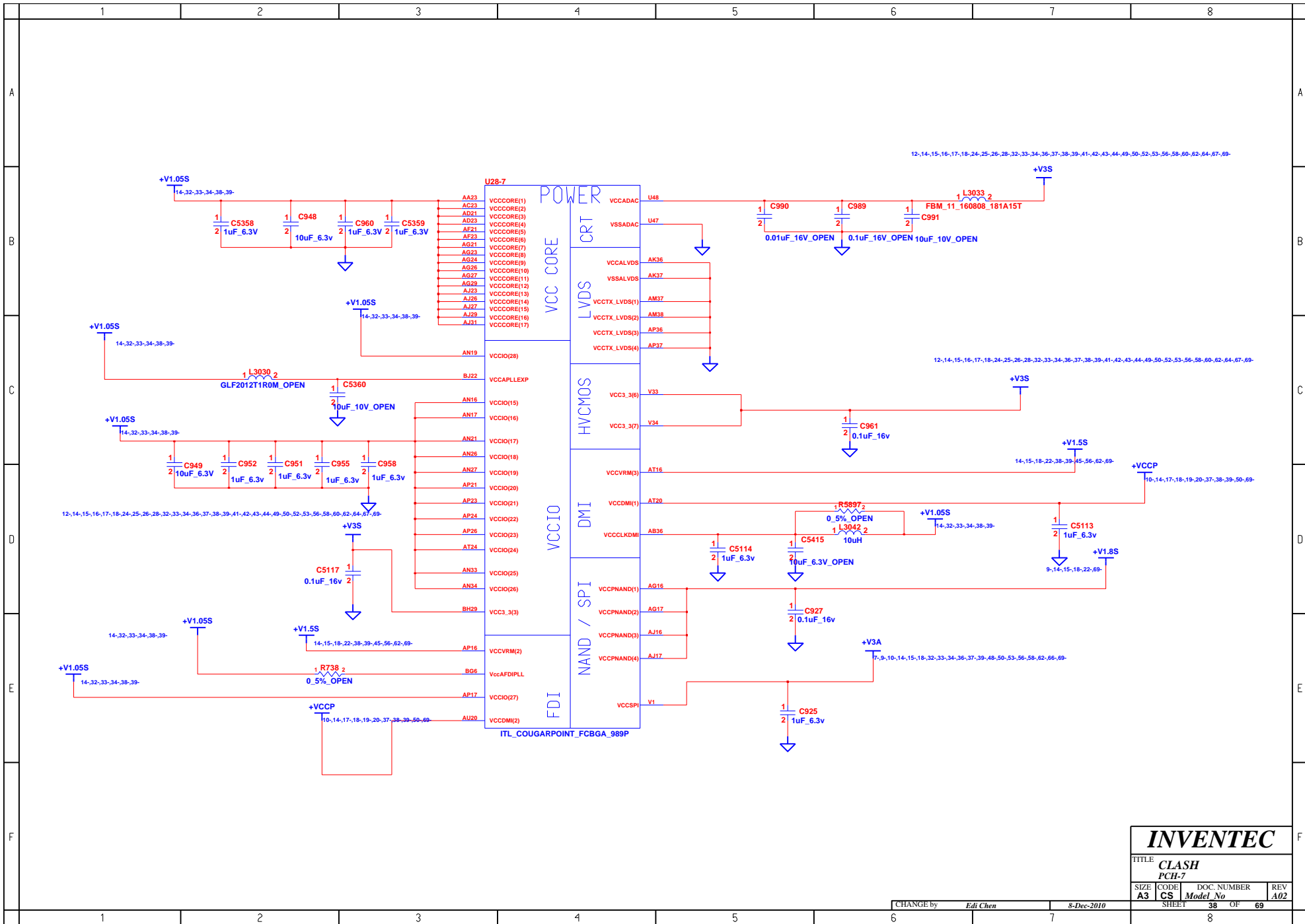

<b>INVENTEC</b>			
TITLE CLASH PCH-7			
SIZE A3	CODE CS	DOC. NUMBER Model No	REV A02
CHANGE by Edi Chen		8-Dec-2010	
SHEET 38		OF 69	

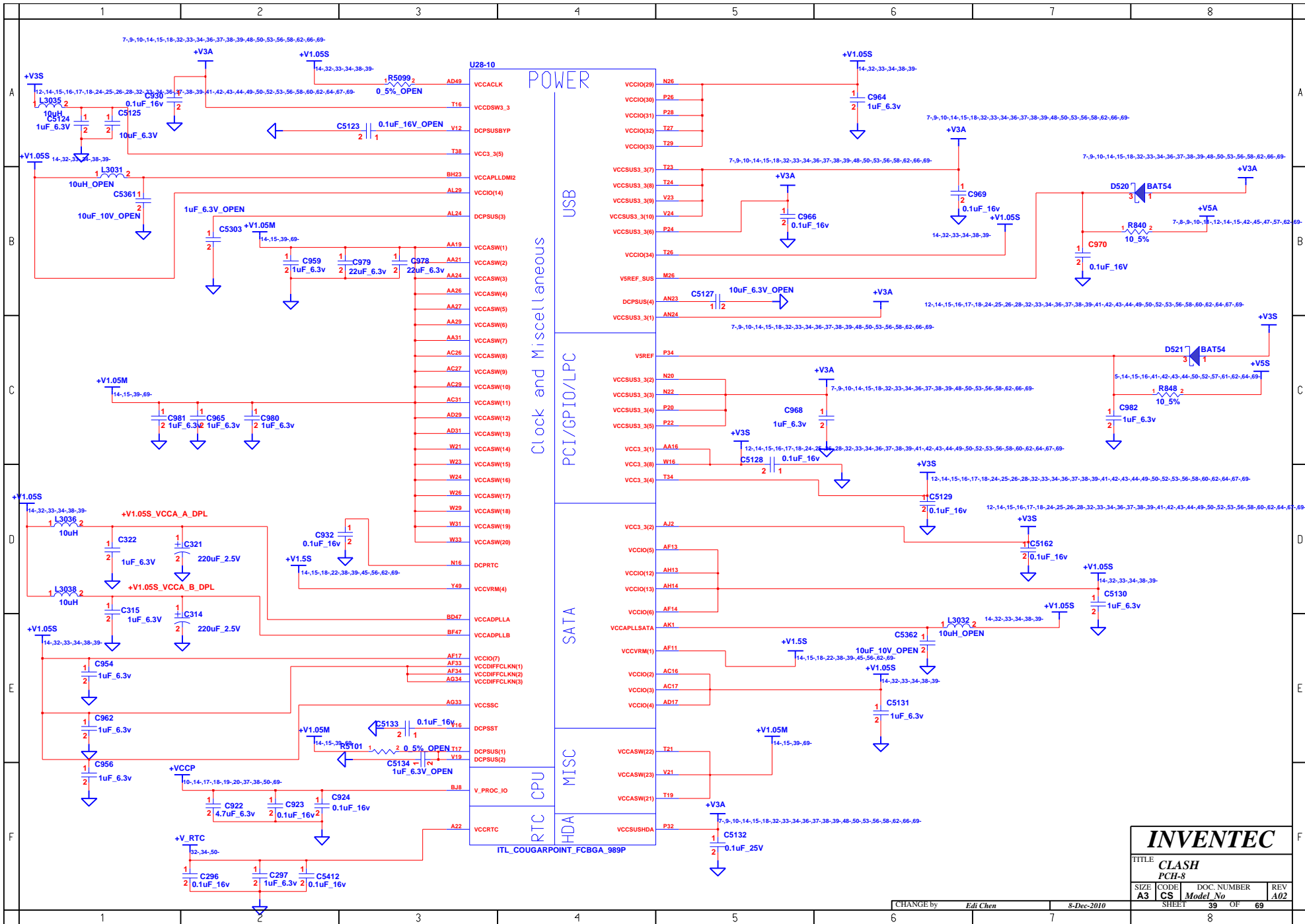

<b>INVENTEC</b>			
TITLE <b>CLASH</b>			
PCH-8			
SIZE <b>A3</b>	CODE <b>CS</b>	DOC NUMBER <i>Model No</i>	REV <b>A02</b>
SHEET <b>39</b>		OF <b>69</b>	

CHANGE by *Edi Chen* 8-Dec-2010

<http://sualaptop365.edu.vn>

	1	2	3	4	5	6	7	8	
A									
B									
C									
D									
E									
F									

U28-8		U28-9	
HS VSS(0)	VSS(80) AK38	AY4 VSS(159)	VSS(259) H46
AA17 VSS(1)	VSS(81) AK4	AY42 VSS(160)	VSS(260) K18
AA2 VSS(2)	VSS(82) AK42	AY46 VSS(161)	VSS(261) K26
AA3 VSS(3)	VSS(83) AK46	AY8 VSS(162)	VSS(262) K39
AA33 VSS(4)	VSS(84) AK8	B11 VSS(163)	VSS(263) K46
AA34 VSS(5)	VSS(85) AL16	B15 VSS(164)	VSS(264) K7
AB11 VSS(6)	VSS(86) AL17	B19 VSS(165)	VSS(265) L18
AB14 VSS(7)	VSS(87) AL19	B23 VSS(166)	VSS(266) L2
AB39 VSS(8)	VSS(88) AL2	B47 VSS(167)	VSS(267) L26
AB4 VSS(9)	VSS(89) AL23	B51 VSS(168)	VSS(268) L28
AB5 VSS(10)	VSS(90) AL26	B55 VSS(169)	VSS(269) L36
AB7 VSS(11)	VSS(91) AL27	B59 VSS(170)	VSS(270) L43
AC19 VSS(12)	VSS(92) AL31	F45 VSS(171)	VSS(271) M12
AC2 VSS(13)	VSS(93) AL33	F47 VSS(172)	VSS(272) M22
AC21 VSS(14)	VSS(94) AL34	BB12 VSS(173)	VSS(273) P16
AC24 VSS(15)	VSS(95) AL46	BB16 VSS(174)	VSS(274) M18
AC33 VSS(16)	VSS(96) AM11	BB20 VSS(175)	VSS(275) M24
AC34 VSS(17)	VSS(97) AM14	BB22 VSS(176)	VSS(276) M30
AC48 VSS(18)	VSS(98) AM36	BB24 VSS(177)	VSS(277) M32
AD10 VSS(19)	VSS(99) AM39	BB28 VSS(178)	VSS(278) M34
AD11 VSS(20)	VSS(100) AM43	BB30 VSS(179)	VSS(279) M38
AD12 VSS(21)	VSS(101) AM45	BB38 VSS(180)	VSS(280) M4
AD13 VSS(22)	VSS(102) AM46	BB4 VSS(181)	VSS(281) M42
AD19 VSS(23)	VSS(103) AN2	BB46 VSS(182)	VSS(282) M6
AD24 VSS(24)	VSS(104) AN29	BB54 VSS(183)	VSS(283) M8
AD26 VSS(25)	VSS(105) AN3	BB58 VSS(184)	VSS(284) M18
AD27 VSS(26)	VSS(106) AN1	BC2 VSS(185)	VSS(285) N18
AD33 VSS(27)	VSS(107) AP12	BC22 VSS(186)	VSS(286) P30
AD34 VSS(28)	VSS(108) AP19	BC26 VSS(187)	VSS(287) M2
AD36 VSS(29)	VSS(109) AP28	BC32 VSS(188)	VSS(288) P11
AD37 VSS(30)	VSS(110) AP28	BC34 VSS(189)	VSS(289) P18
AD38 VSS(31)	VSS(111) AP32	BC36 VSS(190)	VSS(290) P33
AD4 VSS(32)	VSS(112) AP38	BC40 VSS(191)	VSS(291) P40
AD40 VSS(33)	VSS(113) AP4	BC42 VSS(192)	VSS(292) P43
AD42 VSS(34)	VSS(114) AP42	BC48 VSS(193)	VSS(293) P7
AD43 VSS(35)	VSS(115) AP46	BD46 VSS(194)	VSS(294) R2
AD44 VSS(36)	VSS(116) AP8	BD5 VSS(195)	VSS(295) R48
AD45 VSS(37)	VSS(117) AR2	BE22 VSS(196)	VSS(296) T11
AD46 VSS(38)	VSS(118) AR28	BE26 VSS(197)	VSS(297) T12
AD8 VSS(39)	VSS(119) AT11	BE40 VSS(198)	VSS(298) T31
AE2 VSS(40)	VSS(120) AT13	BF10 VSS(199)	VSS(299) T4
AE3 VSS(41)	VSS(121) AT18	BF12 VSS(200)	VSS(300) W34
AF10 VSS(42)	VSS(122) AT22	BF16 VSS(201)	VSS(301) T46
AF12 VSS(43)	VSS(123) AT26	BF20 VSS(202)	VSS(302) T47
AF14 VSS(44)	VSS(124) AT28	BF22 VSS(203)	VSS(303) T8
AF16 VSS(45)	VSS(125) AT32	BF24 VSS(204)	VSS(304) Y11
AF18 VSS(46)	VSS(126) AT34	AR2 VSS(205)	VSS(305) Y26
AF24 VSS(47)	VSS(127) AT39	AR28 VSS(206)	VSS(306) Y27
AF28 VSS(48)	VSS(128) AT46	BD3 VSS(207)	VSS(307) Y29
AF29 VSS(49)	VSS(129) AT7	BF30 VSS(208)	VSS(308) Y31
AF32 VSS(50)	VSS(130) AU24	BF38 VSS(209)	VSS(309) Y36
AF38 VSS(51)	VSS(131) AU24	BF40 VSS(210)	VSS(310) Y39
AF4 VSS(52)	VSS(132) AV16	BF46 VSS(211)	VSS(311) Y43
AF42 VSS(53)	VSS(133) AV20	BG21 VSS(212)	VSS(312) Y7
AF46 VSS(54)	VSS(134) AV26	BG33 VSS(213)	VSS(313) W17
AF5 VSS(55)	VSS(135) AV38	BG44 VSS(214)	VSS(314) W19
AF7 VSS(56)	VSS(136) AV43	BG58 VSS(215)	VSS(315) W27
AF8 VSS(57)	VSS(137) AV9	BH11 VSS(216)	VSS(316) W48
AF9 VSS(58)	VSS(138) AW18	BH15 VSS(217)	VSS(317) Y12
AG19 VSS(59)	VSS(139) AW22	BH17 VSS(218)	VSS(318) Y12
AG2 VSS(60)	VSS(140) AW26	BH19 VSS(219)	VSS(319) Y12
AG21 VSS(61)	VSS(141) AW28	BH27 VSS(220)	VSS(320) Y4
AG31 VSS(62)	VSS(142) AW34	BH31 VSS(221)	VSS(321) Y42
AG48 VSS(63)	VSS(143) AW38	BH33 VSS(222)	VSS(322) Y46
AH11 VSS(64)	VSS(144) AW40	BH39 VSS(223)	VSS(323) Y8
AH3 VSS(65)	VSS(145) AW43	BH43 VSS(224)	VSS(324) Y8
AH38 VSS(66)	VSS(146) AW46	BH47 VSS(225)	VSS(325) BG29
AH39 VSS(67)	VSS(147) AW50	BH51 VSS(226)	VSS(326) N24
AH40 VSS(68)	VSS(148) AW54	D1 VSS(227)	VSS(327) A33
AH42 VSS(69)	VSS(149) AW58	D12 VSS(228)	VSS(328) A34
AH46 VSS(70)	VSS(150) AW62	D18 VSS(229)	VSS(329) BE10
AH7 VSS(71)	VSS(151) AW66	D22 VSS(230)	VSS(330) BE10
AJ19 VSS(72)	VSS(152) AW72	D24 VSS(231)	VSS(331) G41
AJ21 VSS(73)	VSS(153) AW76	D26 VSS(232)	VSS(332) G14
AJ24 VSS(74)	VSS(154) AW82	D30 VSS(233)	VSS(333) H16
AJ3 VSS(75)	VSS(155) AW86	D32 VSS(234)	VSS(334) T36
AJ34 VSS(76)	VSS(156) AW94	D34 VSS(235)	VSS(335) BG24
AK12 VSS(77)	VSS(157) AW98	D38 VSS(236)	VSS(336) BG24
AK3 VSS(78)	VSS(158) AY22	D42 VSS(237)	VSS(337) C22
AK3 VSS(79)	VSS(159) AY28	D44 VSS(238)	VSS(338) AP13
		D48 VSS(239)	VSS(339) M14
		D52 VSS(240)	VSS(340) AP3
		D54 VSS(241)	VSS(341) AP1
		D58 VSS(242)	VSS(342) BE16
		D62 VSS(243)	VSS(343) BE16
		D66 VSS(244)	VSS(344) BG28
		D70 VSS(245)	VSS(345) BJ28
		D74 VSS(246)	
		D78 VSS(247)	
		D82 VSS(248)	
		D86 VSS(249)	
		D90 VSS(250)	
		D94 VSS(251)	
		D98 VSS(252)	
		H2 H24	
		H26 VSS(254)	
		H30 VSS(255)	
		H32 VSS(256)	
		H34 VSS(257)	
		F3 VSS(258)	

  

ITL COUGARPOINT_FCBGA_989P		ITL COUGARPOINT_FCBGA_989P	
----------------------------	--	----------------------------	--

<b>INVENTEC</b>			
TITLE <b>CLASH PCH-9</b>			
SIZE <b>A3</b>	CODE <b>CS</b>	DOC. NUMBER <b>Model No</b>	REV <b>A02</b>
CHANGE by <b>Edi Chen</b>		8-Dec-2010	
SHEET <b>40</b>		OF <b>69</b>	



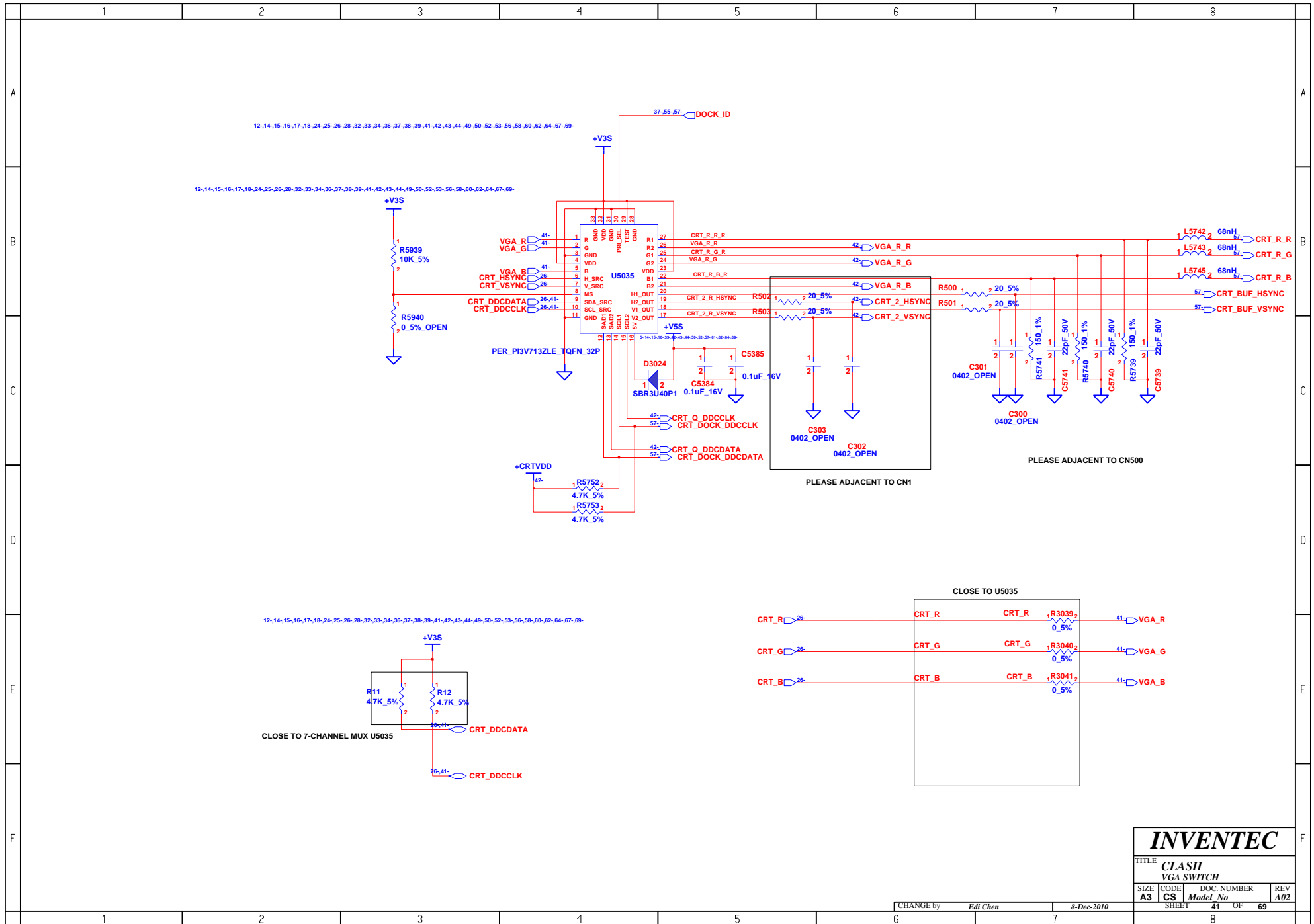

# INVENTEC

TITLE			
CLASH			
VGA SWITCH			
SIZE	CODE	DOC NUMBER	REV
A3	CS	Model No	A02

CHANGE by	Edi Chen	8-Dec-2010	SHEET	41	OF	69
-----------	----------	------------	-------	----	----	----

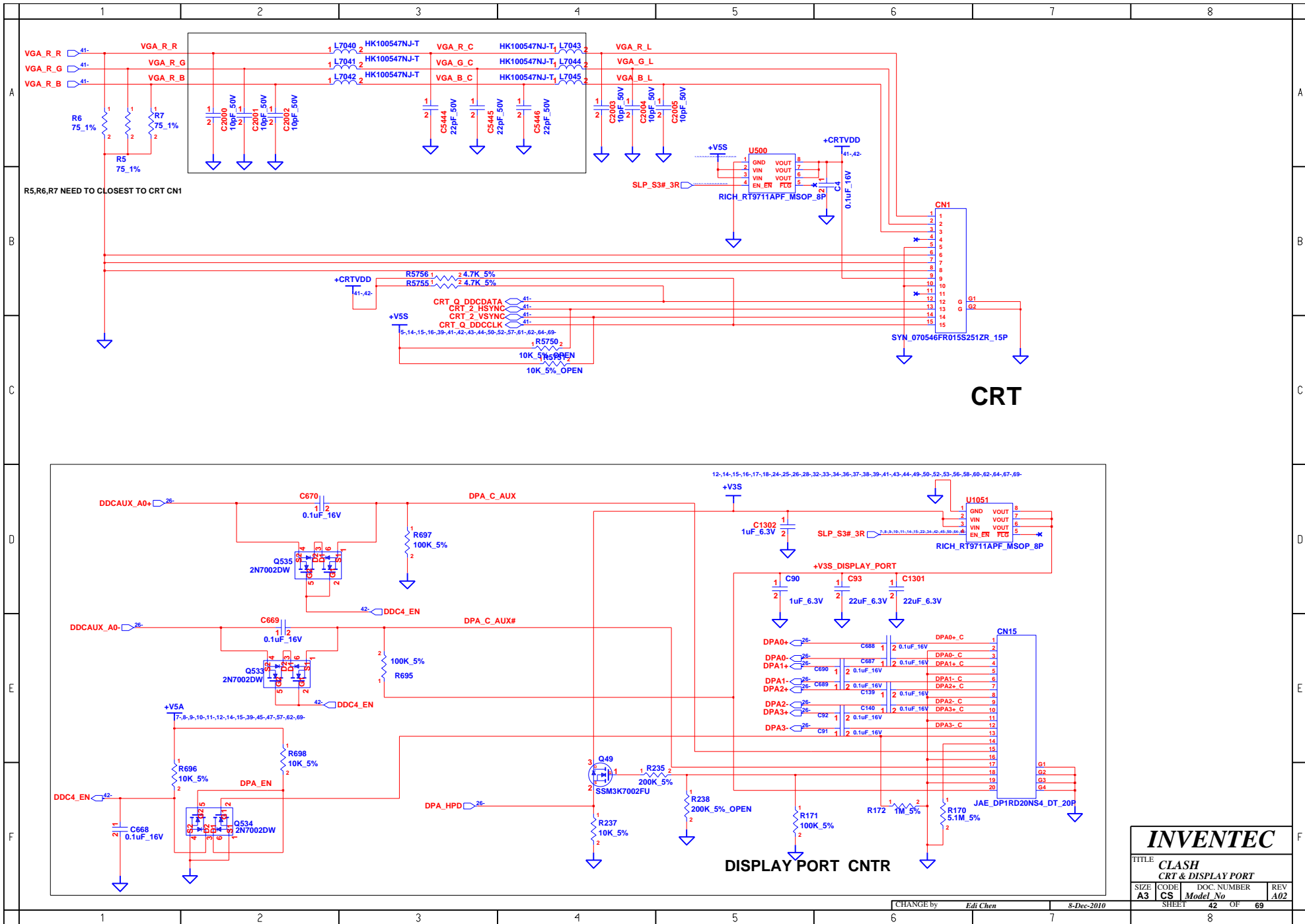

**CRT**

**DISPLAY PORT CNTR**

**INVENTEC**

TITLE  
**CLASH**

**CRT & DISPLAY PORT**

SIZE <b>A3</b>	CODE <b>CS</b>	DOC NUMBER <i>Model No</i>	REV <b>A02</b>
-------------------	-------------------	-------------------------------	-------------------

CHANGE by <i>Edi Chen</i>		8-Dec-2010	
SHEET <b>42</b>		OF <b>69</b>	

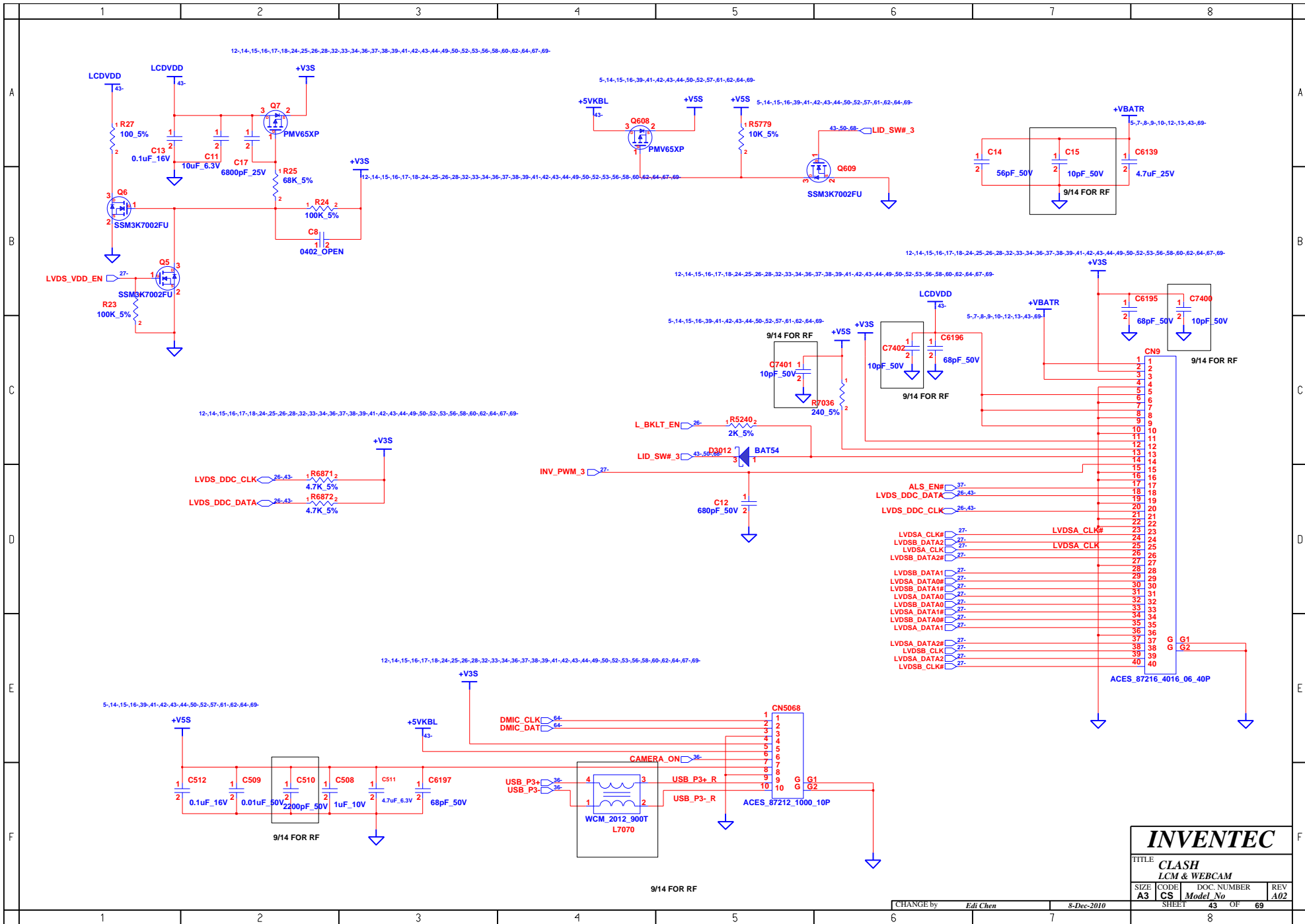

**INVENTEC**

TITLE			
CLASH			
LCM & WEBCAM			
SIZE	CODE	DOC. NUMBER	REV
A3	CS	Model No	A02

CHANGE by	Edi Chen	8-Dec-2010	
SHEET	43	OF	69

<http://sualaptop365.edu.vn>

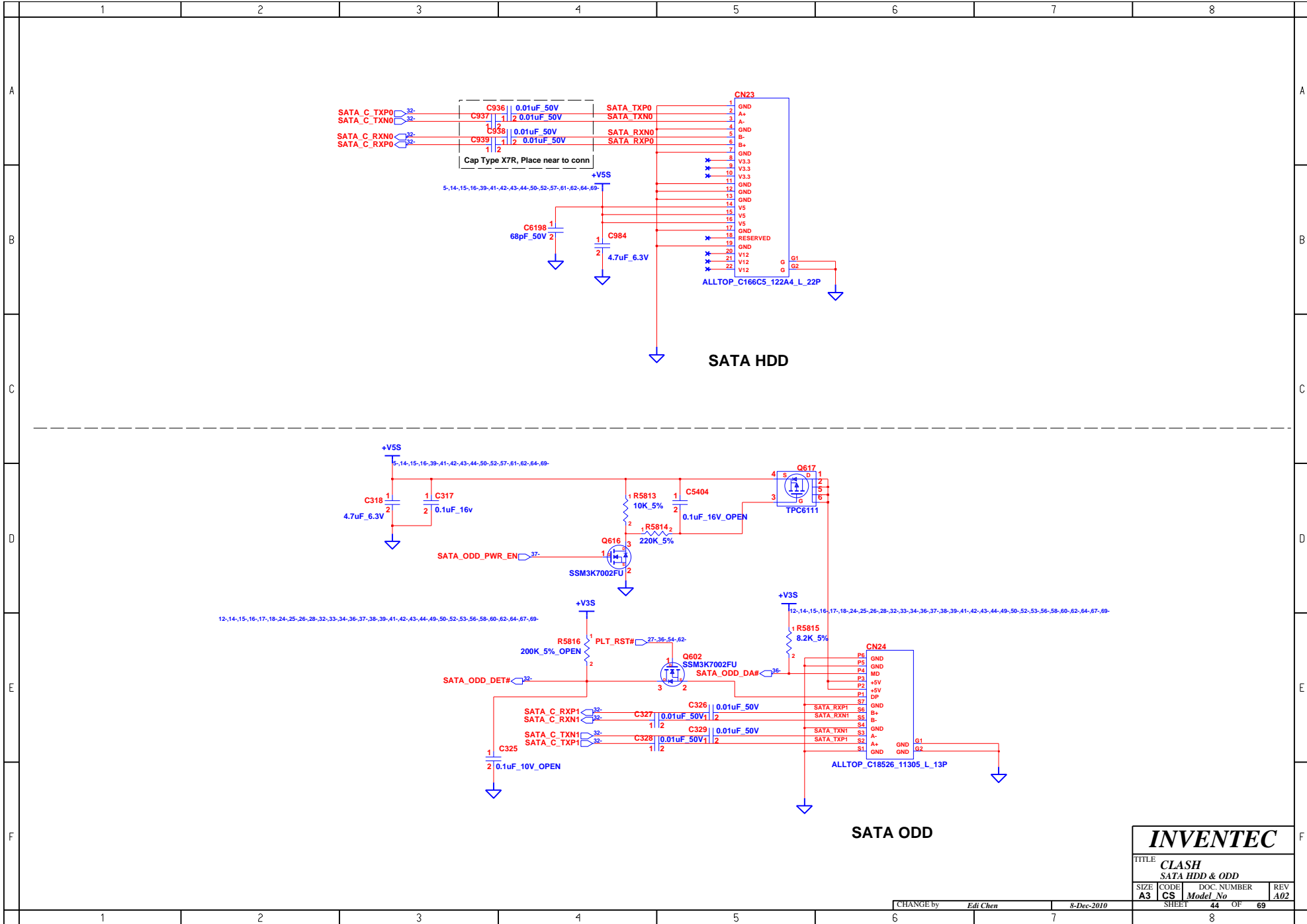

<b>INVENTEC</b>			
TITLE <b>CLASH SATA HDD &amp; ODD</b>			
SIZE <b>A3</b>	CODE <b>CS</b>	DOC. NUMBER <i>Model No</i>	REV <b>A02</b>
CHANGE by <i>Edi Chen</i>		8-Dec-2010	
SHEET <b>44</b>		OF <b>69</b>	

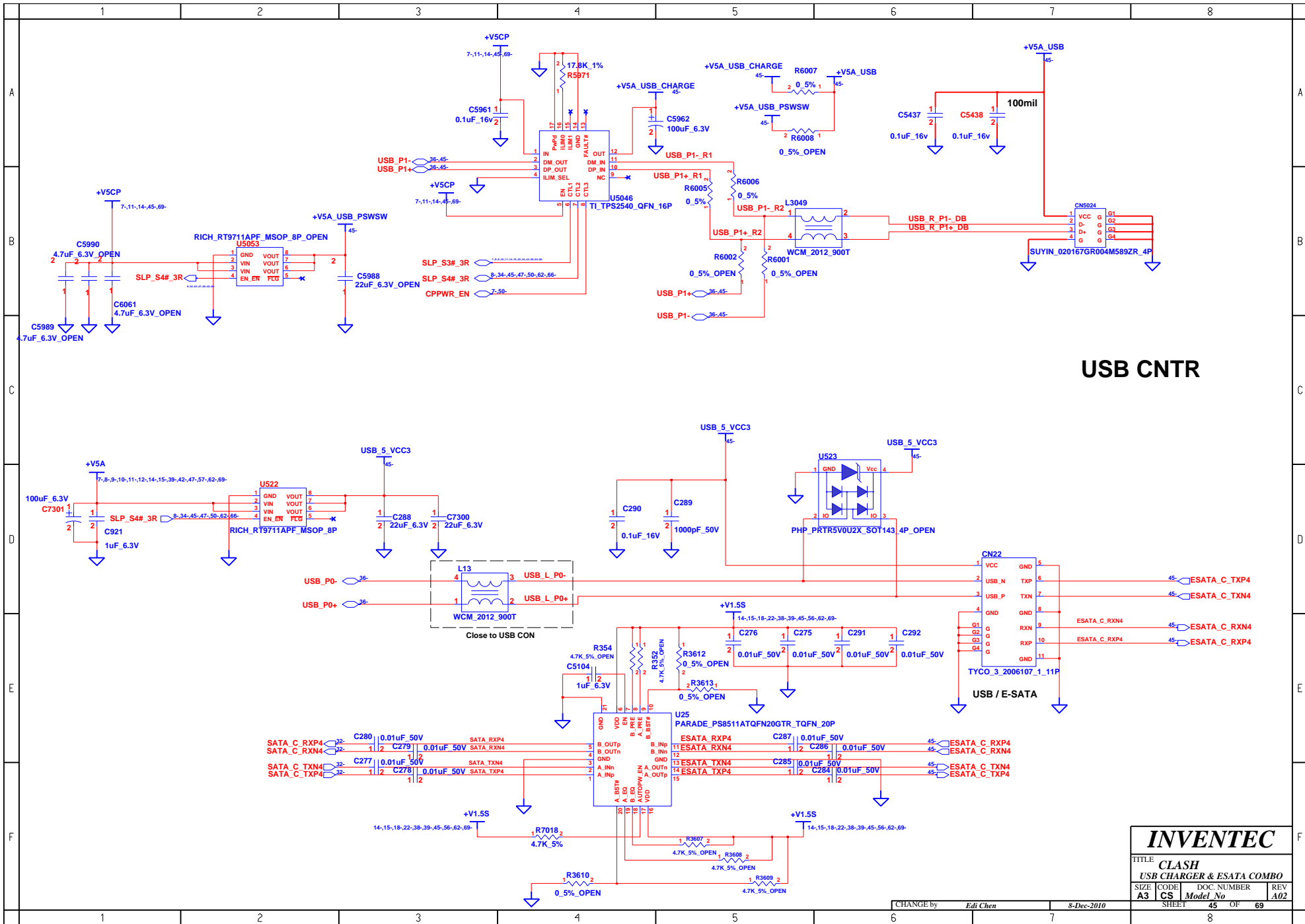

## USB CNTR

<b>INVENTEC</b>			
TITLE <b>CLASH</b>			
USB CHARGER & ESATA COMBO			
SIZE	CODE	DOC. NUMBER	REV
A3	CS	Model No	A02
CHANGE by		Edi Chen	8-Dec-2010
SHEET		45	OF 69

<http://sualaptop365.edu.vn>

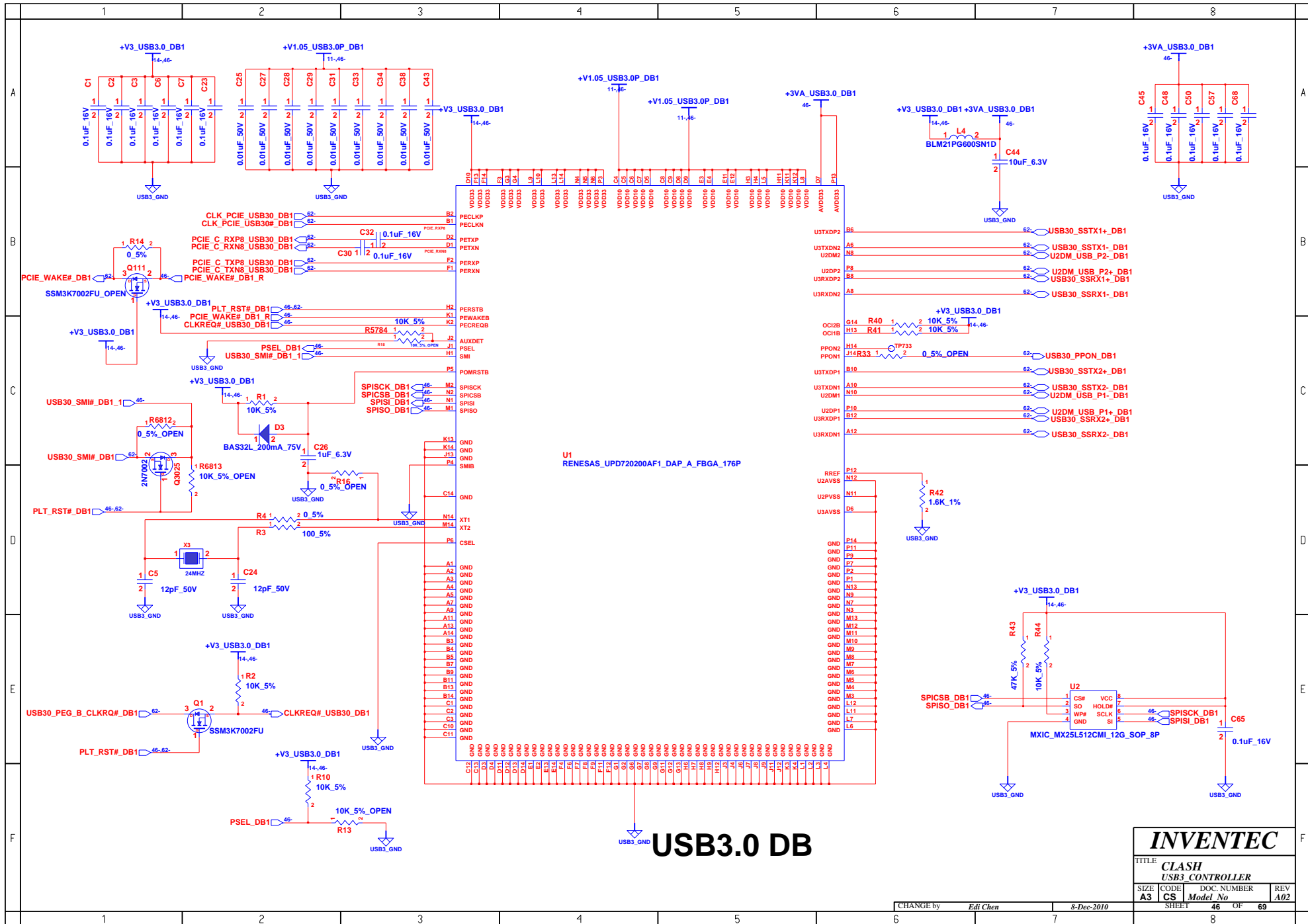

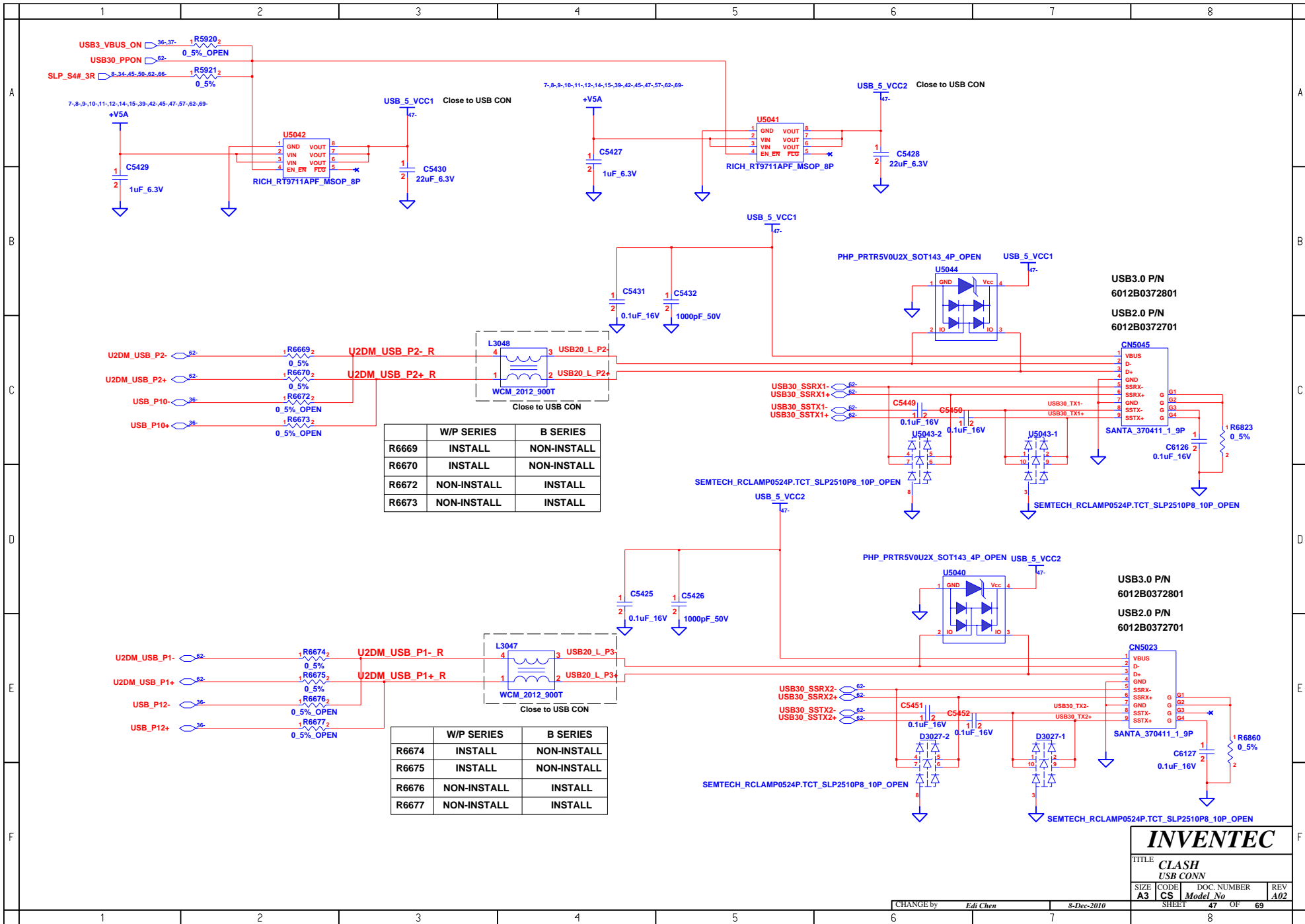

**INVENTEC**

TITLE  
**CLASH**  
USB CONN

SIZE A3	CODE CS	DOC NUMBER Model No	REV A02
------------	------------	------------------------	------------

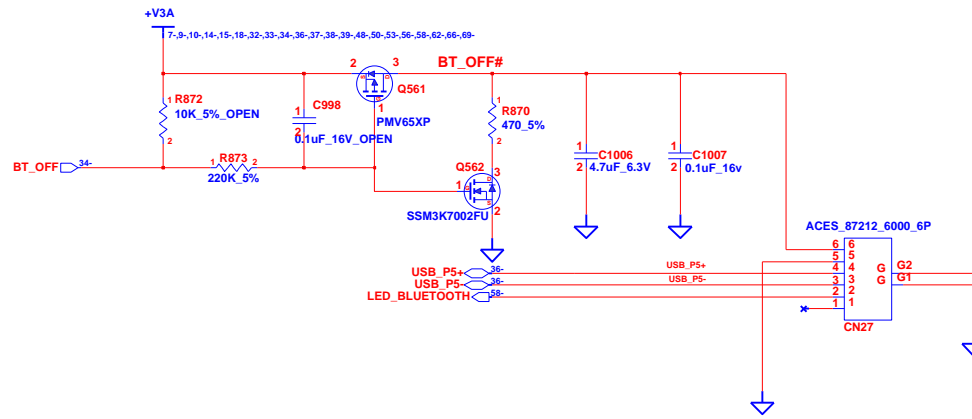

## BLUETOOTH

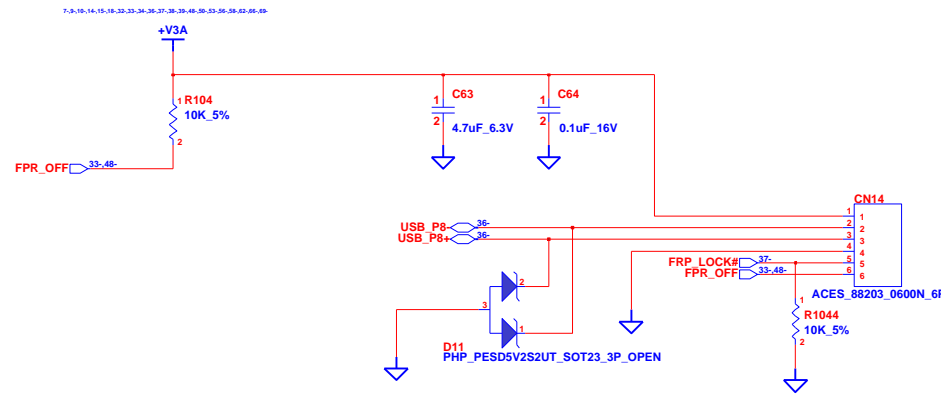

## FINGER PRINTER CNTR

<b>INVENTEC</b>			
TITLE <b>CLASH</b>			
BLUETOOTH & FINGER PRINTER			
SIZE <b>A3</b>	CODE <b>CS</b>	DOC. NUMBER <b>Model No</b>	REV <b>A02</b>
CHANGE by <i>Edi Chen</i>		8-Dec-2010	
SHEET <b>48</b>		OF <b>69</b>	



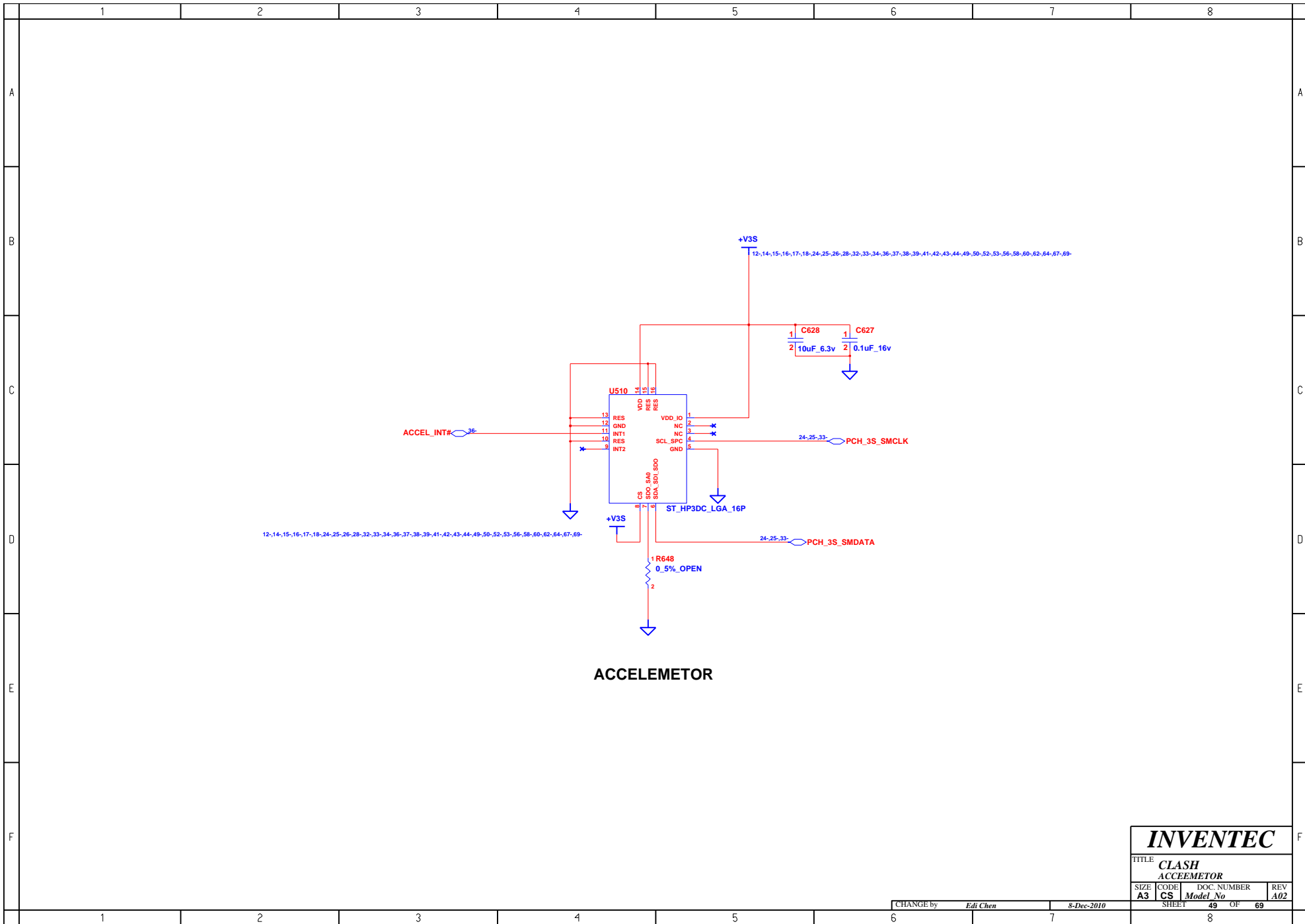

**ACCELEMETOR**

**INVENTEC**

TITLE			
CLASH			
ACCEMETOR			
SIZE	CODE	DOC. NUMBER	REV
A3	CS	Model No	A02

CHANGE by *Edi Chen* 8-Dec-2010

SHEET 49 OF 69

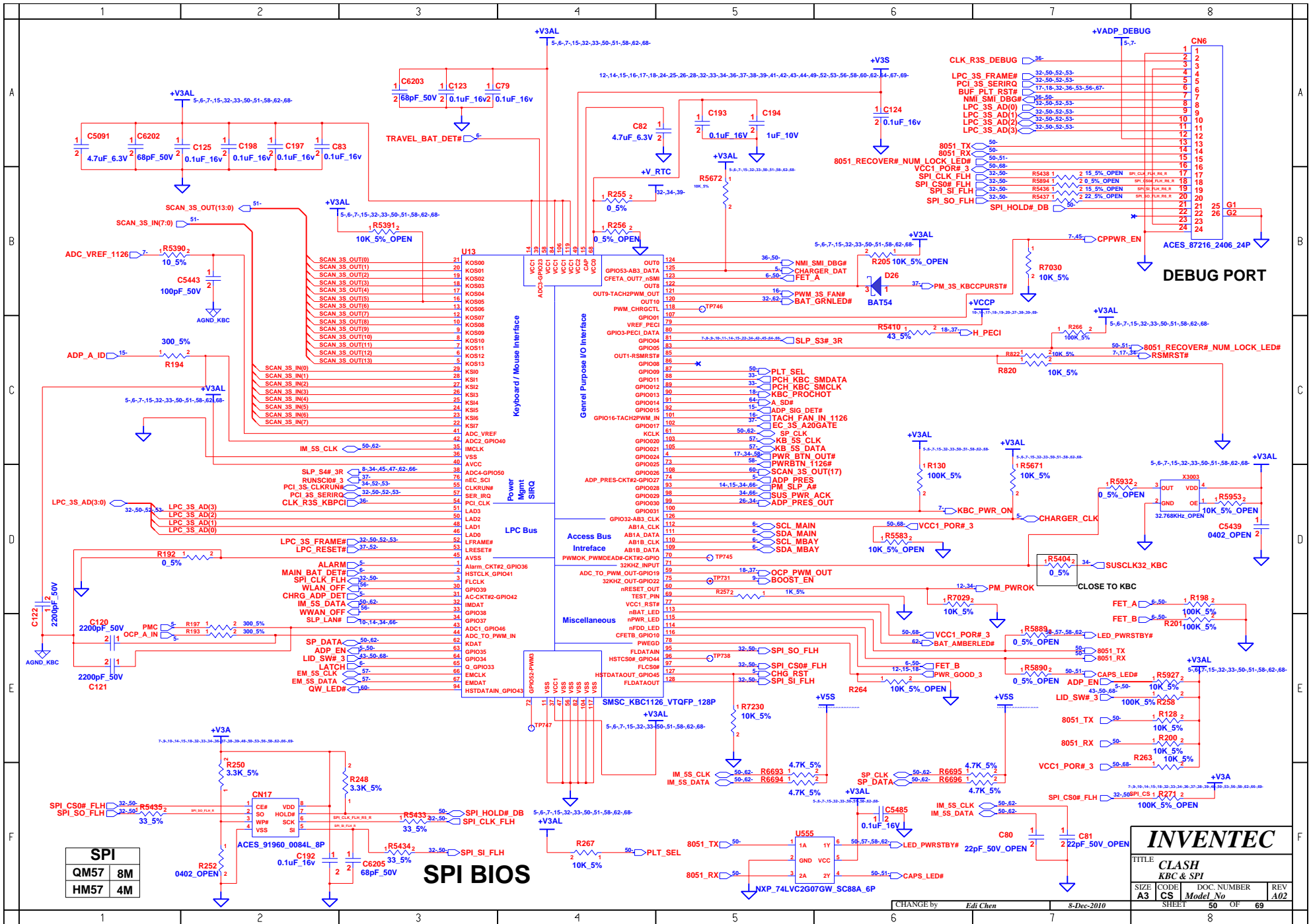

<b>SPI</b>	
QM57	8M
HM57	4M

**SPI BIOS**

<b>INVENTEC</b>			
TITLE <b>CLASH KBC &amp; SPI</b>			
SIZE	CODE	DOC NUMBER	REV
A3	CS	Model No	A02
SHEET 50		OF 69	

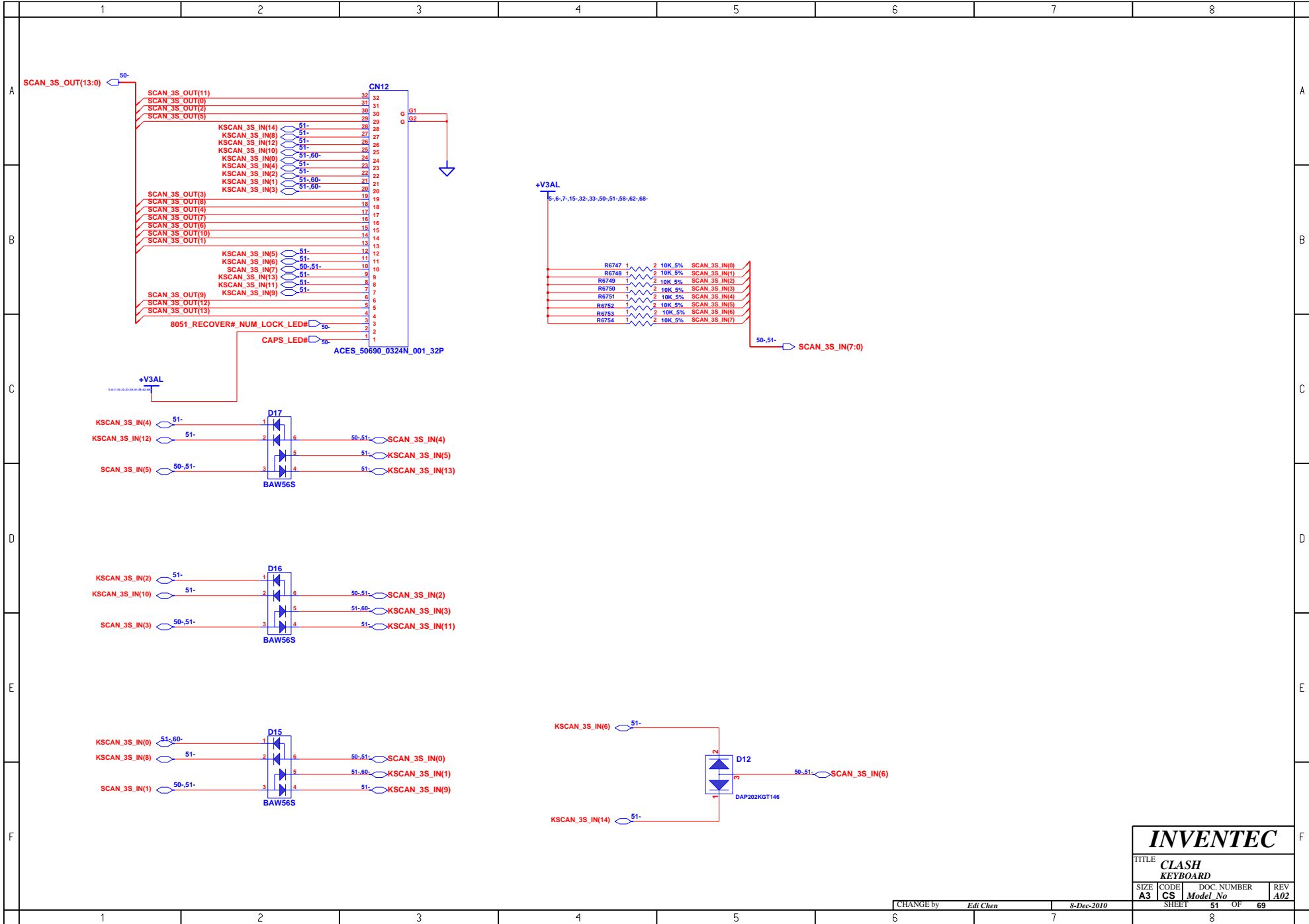

<b>INVENTEC</b>			
TITLE <b>CLASH KEYBOARD</b>			
SIZE <b>A3</b>	CODE <b>CS</b>	DOC. NUMBER <i>Model No</i>	REV <b>A02</b>
CHANGE by <i>Edi Chen</i>		8-Dec-2010	
SHEET		51	OF 69

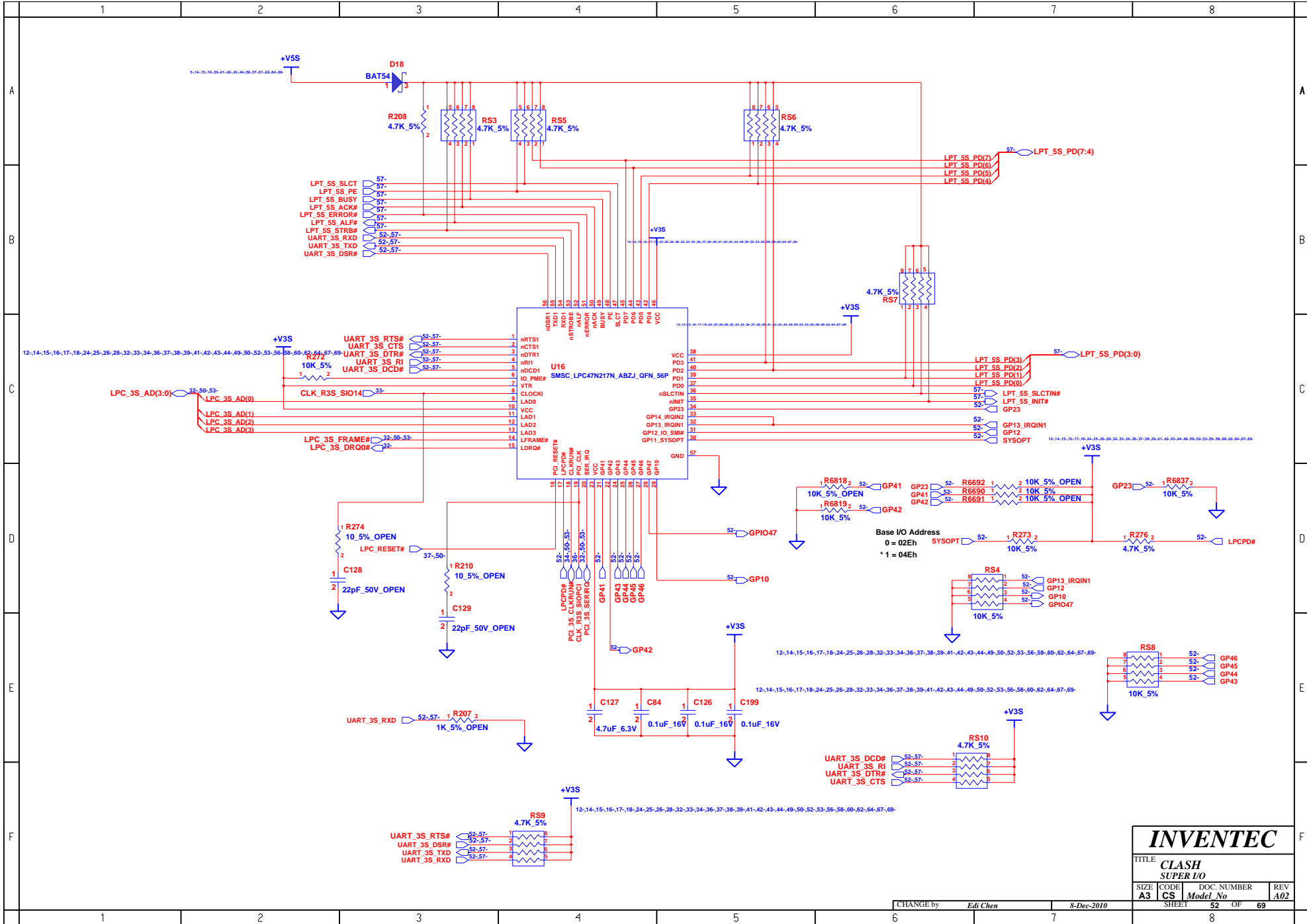

<b>INVENTEC</b>				
TITLE <b>CLASH SUPER I/O</b>				
SIZE <b>A3</b>	CODE <b>CS</b>	DOC. NUMBER <i>Model No</i>	REV <b>A02</b>	
CHANGE by <i>Edi Chen</i>		8-Dec-2010		SHEET 52 OF 69

<http://sualaptop365.edu.vn>

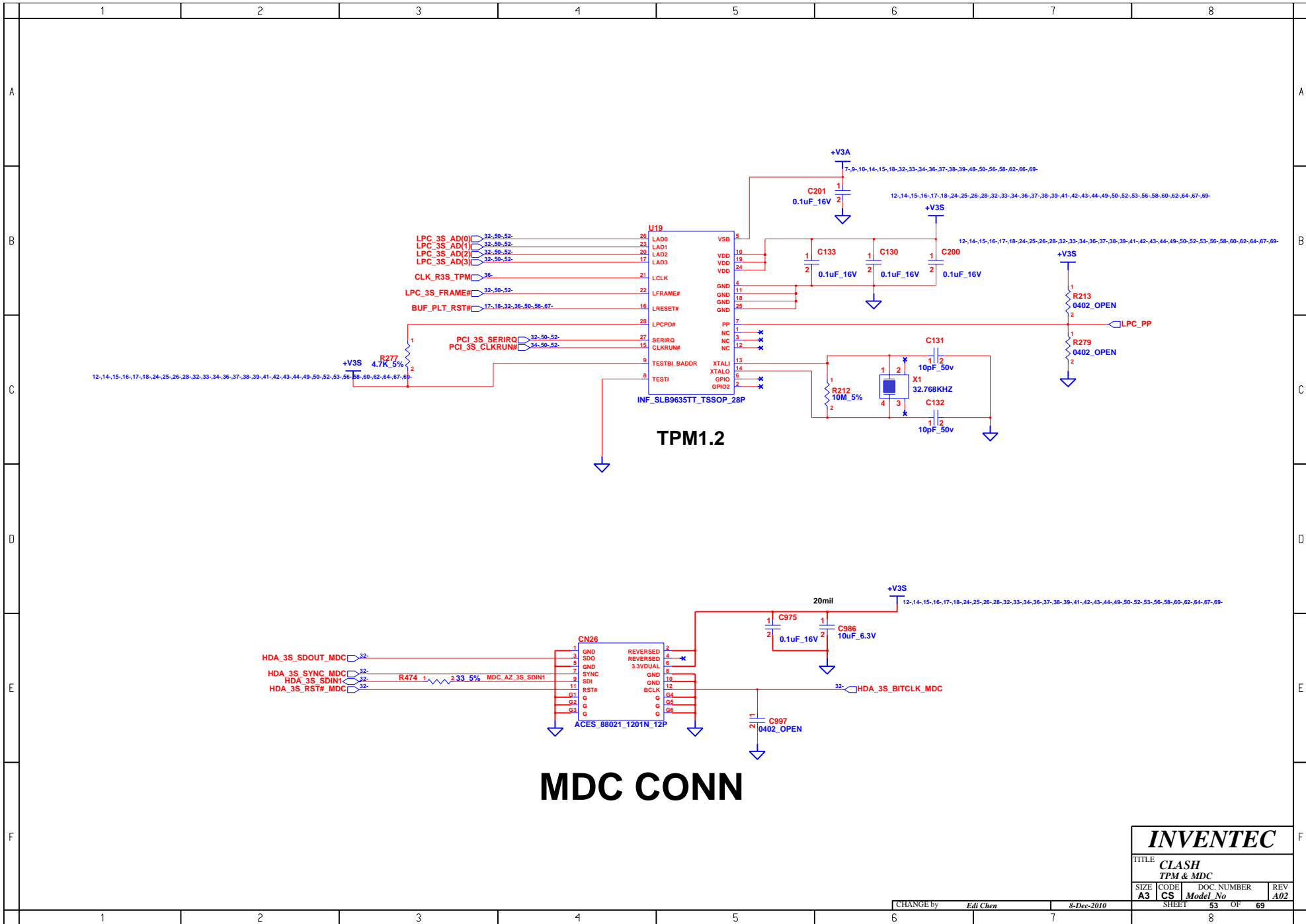

<b>INVENTEC</b>			
TITLE CLASH TPM & MDC			
SIZE A3	CODE CS	DOC. NUMBER Model No	REV A02
CHANGE by Edi Chen		8-Dec-2010	
SHEET 53		OF 69	

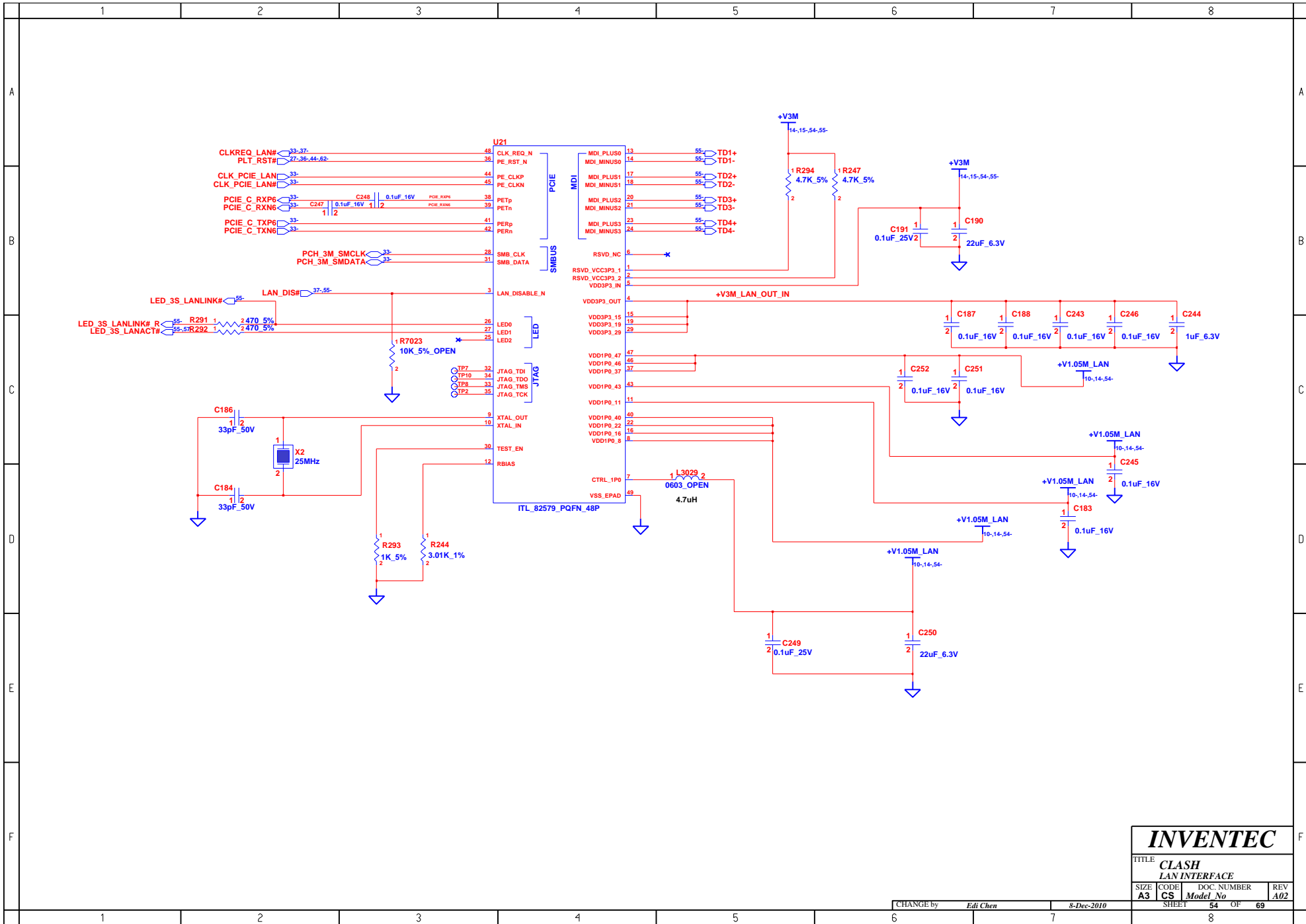

<b>INVENTEC</b>			
TITLE <b>CLASH LAN INTERFACE</b>			
SIZE <b>A3</b>	CODE <b>CS</b>	DOC. NUMBER <i>Model No</i>	REV <b>A02</b>
CHANGE by <i>Edi Chen</i>		8-Dec-2010	SHEET 54 OF 69

<http://sualaptop365.edu.vn>

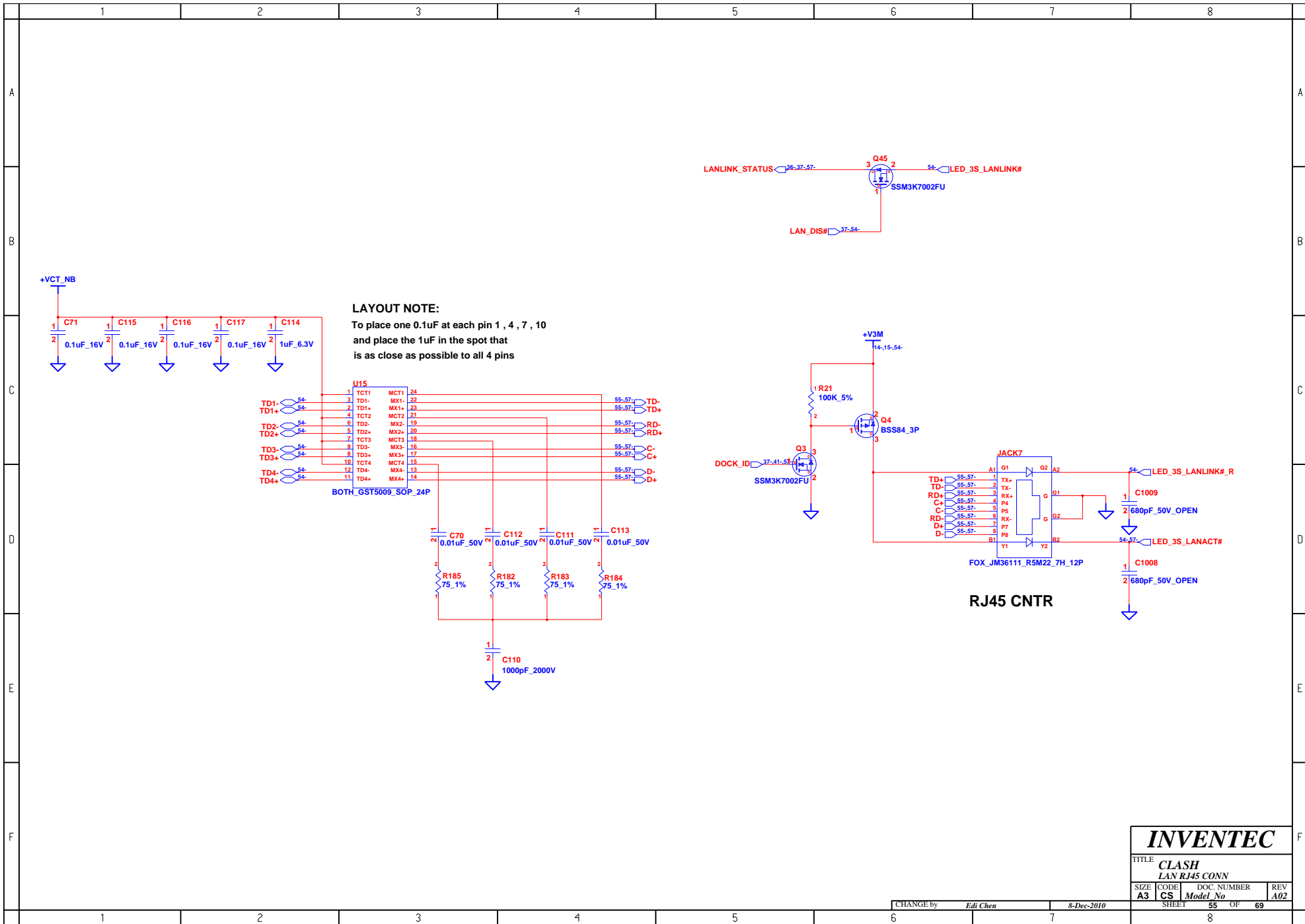

**INVENTEC**

TITLE			
CLASH			
LAN RJ45 CONN			
SIZE	CODE	DOC. NUMBER	REV
A3	CS	Model No	A02
CHANGE by		Edi Chen	8-Dec-2010
SHEET		55	OF 69

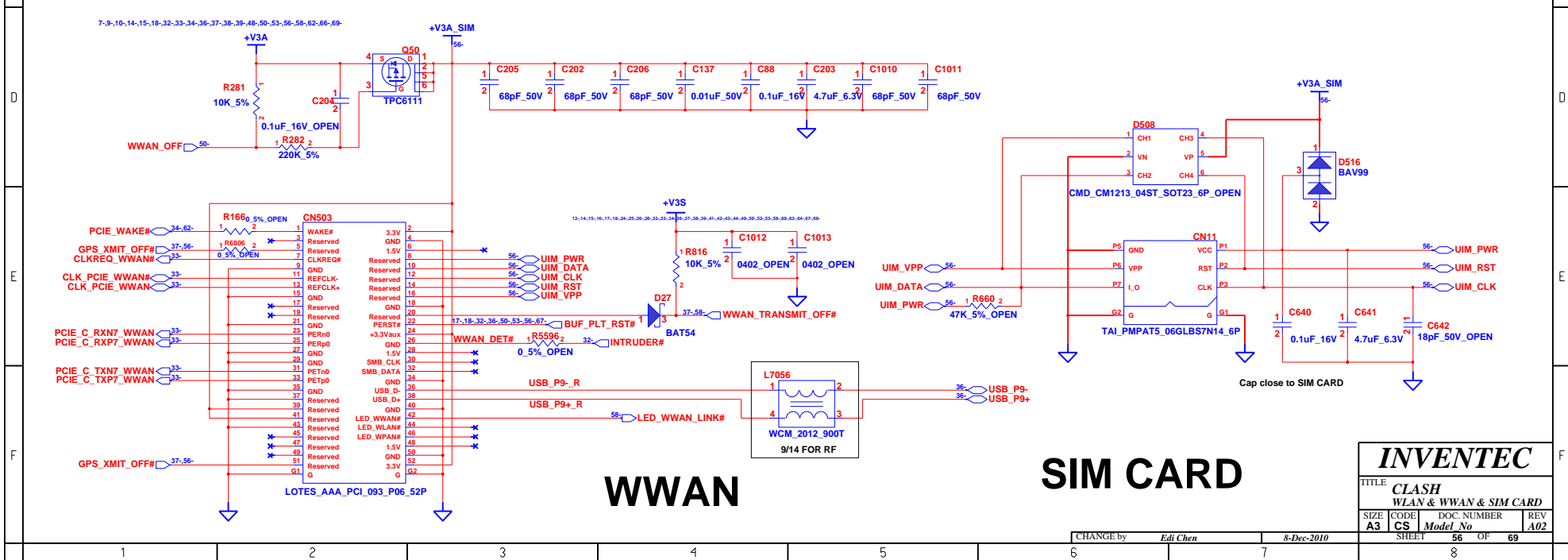
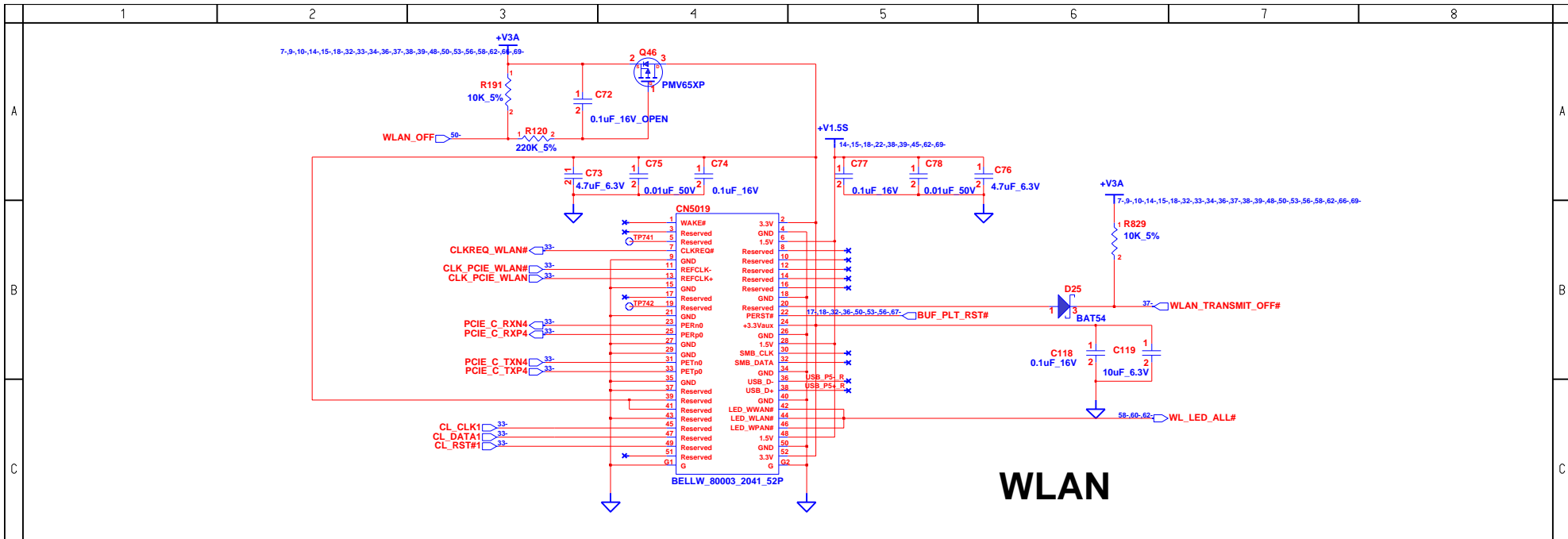

<b>INVENTEC</b>			
TITLE <b>CLASH</b>			
WLAN & WWAN & SIM CARD			
SIZE <b>A3</b>	CODE <b>CS</b>	DOC NUMBER <b>Model No</b>	REV <b>A02</b>
SHEET <b>56</b>		OF <b>69</b>	



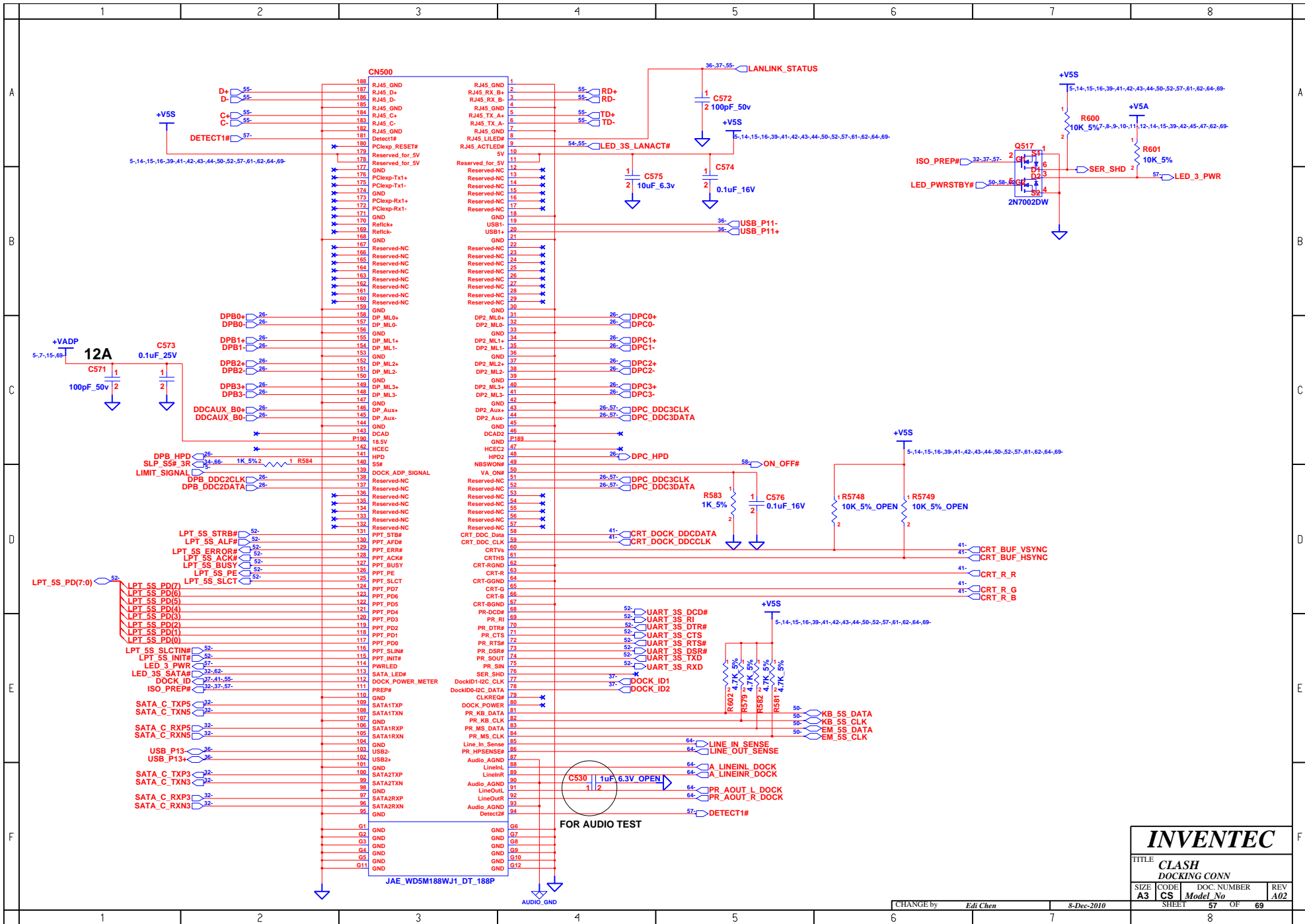

<b>INVENTEC</b>			
TITLE <b>CLASH DOCKING CONN</b>			
SIZE <b>A3</b>	CODE <b>CS</b>	DOC. NUMBER <i>Model No</i>	REV <b>A02</b>
SHEET <b>57</b>		OF <b>69</b>	

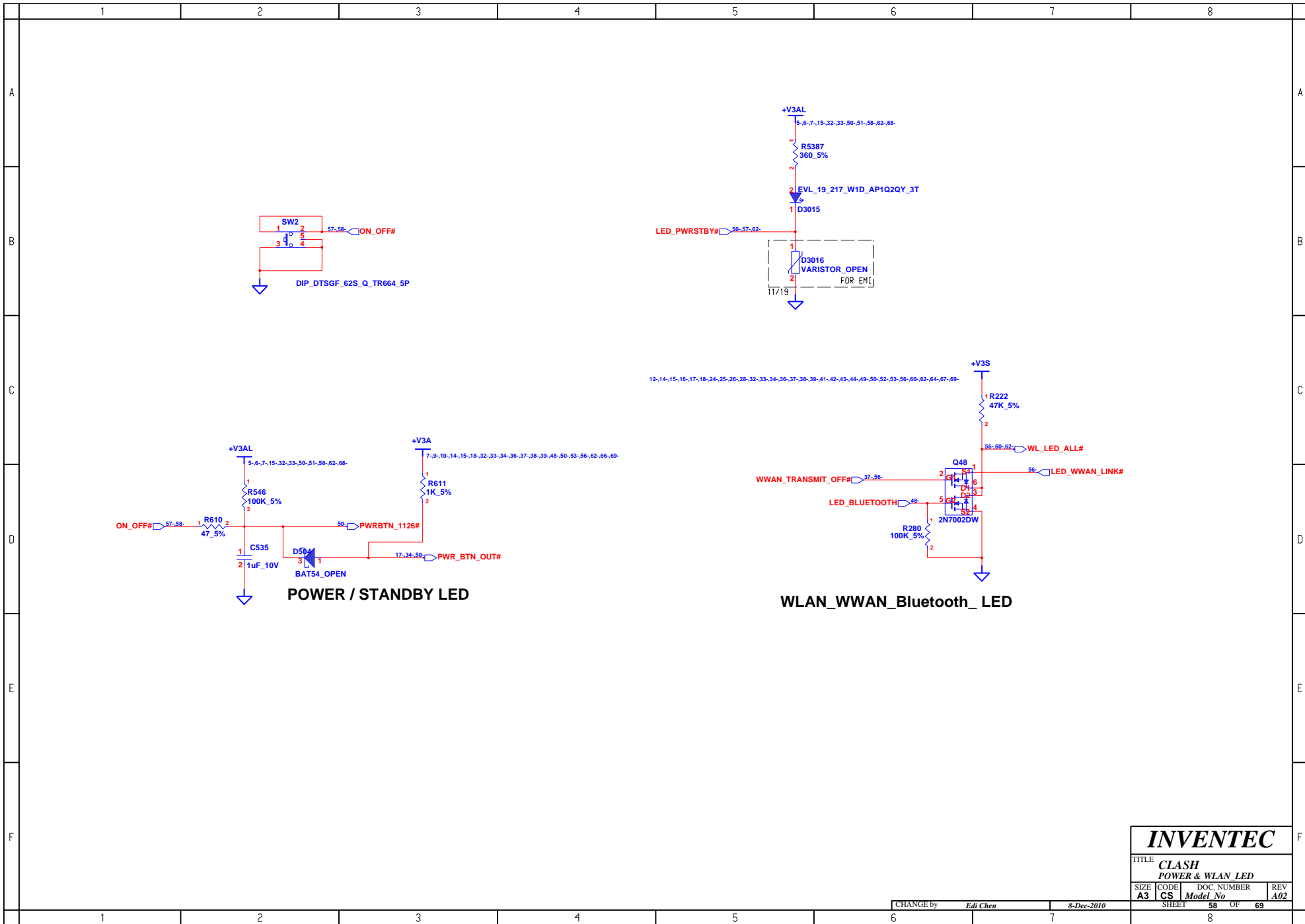

<b>INVENTEC</b>			
TITLE <b>CLASH</b>			
POWER & WLAN_LED			
SIZE <b>A3</b>	CODE <b>CS</b>	DOC. NUMBER <i>Model No</i>	REV <b>A02</b>
CHANGE by <i>Edi Chen</i>		8-Dec-2010	
SHEET <b>58</b>		OF <b>69</b>	

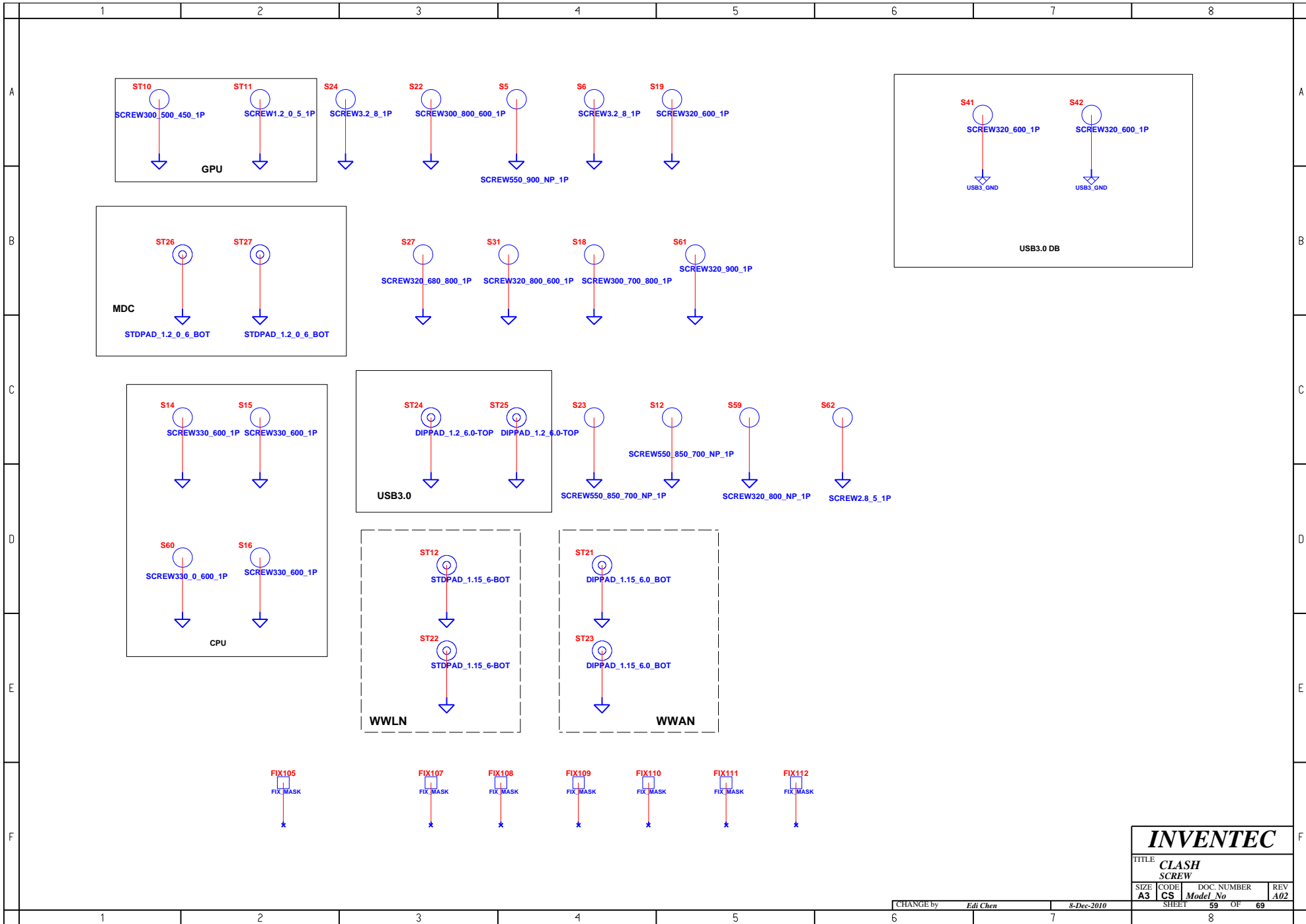

<b>INVENTEC</b>			
TITLE <b>CLASH</b>			
SCREW			
SIZE	CODE	DOC. NUMBER	REV
A3	CS	Model No	A02
CHANGE by <i>Edi Chen</i>		8-Dec-2010	
SHEET 59		OF 69	

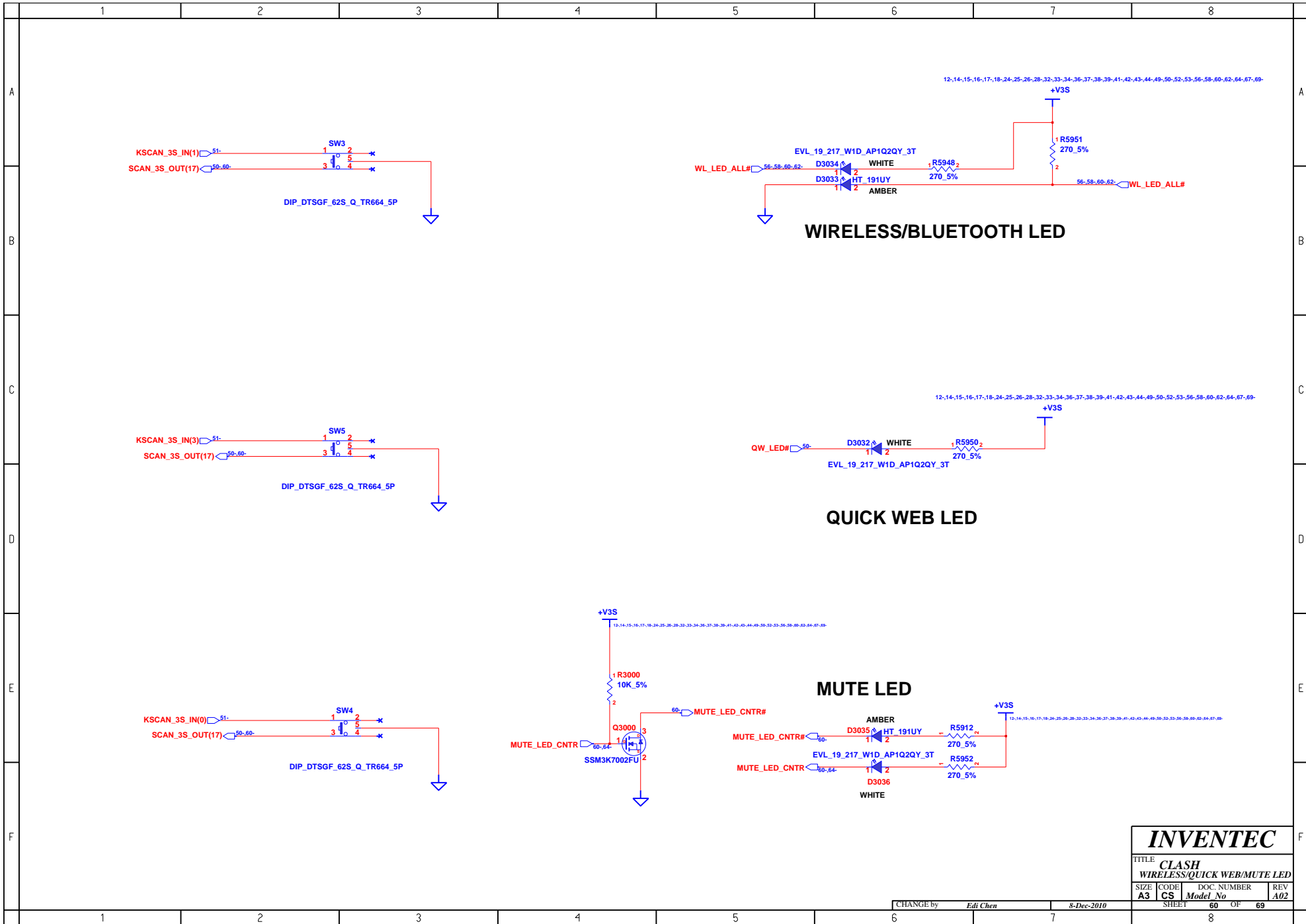

<b>INVENTEC</b>			
TITLE <b>CLASH</b>			
WIRELESS/QUICK WEB/MUTE LED			
SIZE <b>A3</b>	CODE <b>CS</b>	DOC. NUMBER <b>Model No</b>	REV <b>A02</b>
CHANGE by <b>Edi Chen</b>		8-Dec-2010	
SHEET <b>60</b>		OF <b>69</b>	

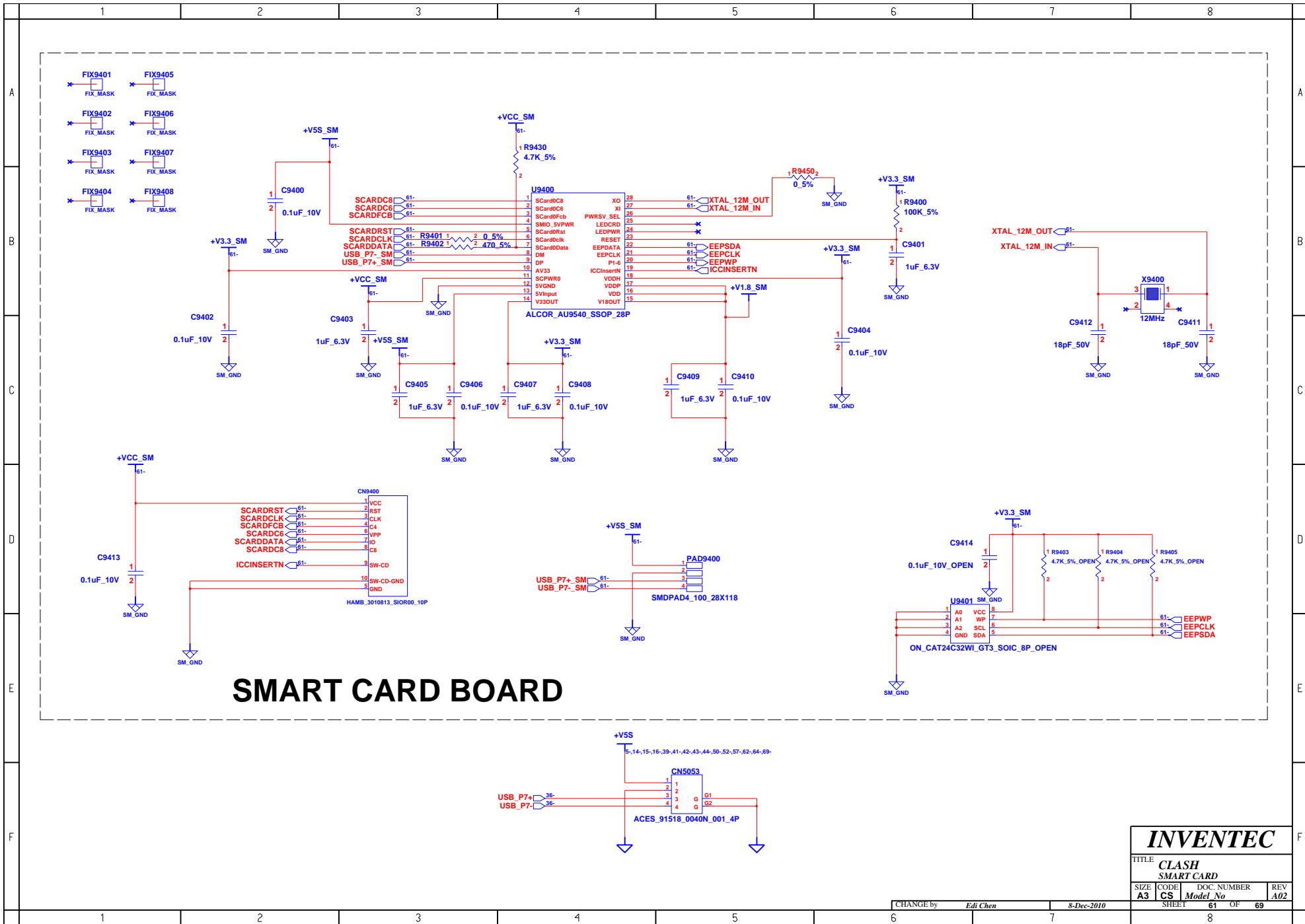

**INVENTEC**

TITLE			
CLASH SMART CARD			
SIZE	CODE	DOC NUMBER	REV
A3	CS	Model No	A02
SHEET		61	OF 69

CHANGE by *Edi Chen* 8-Dec-2010

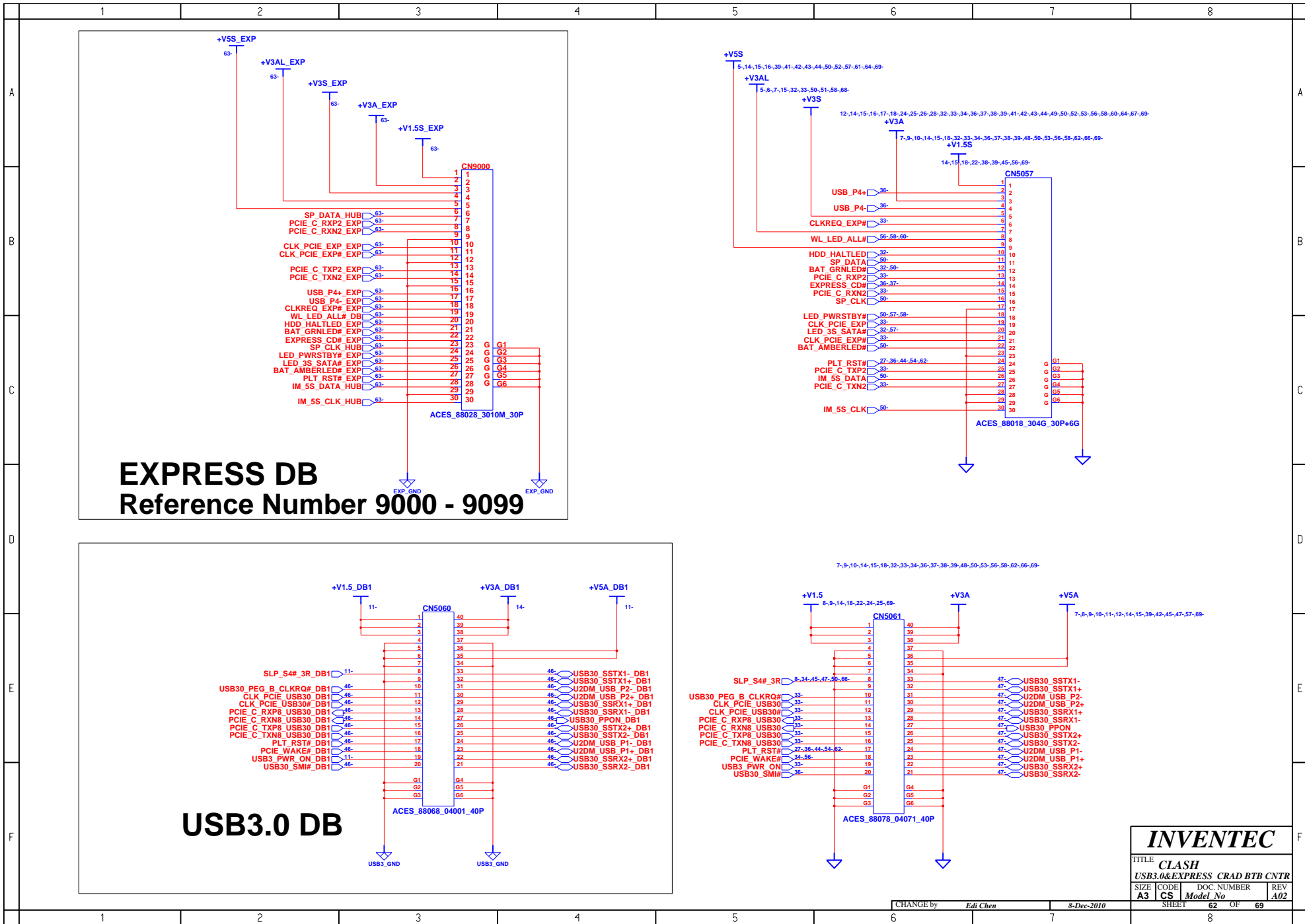

**EXPRESS DB**  
Reference Number 9000 - 9099

**USB3.0 DB**

<b>INVENTEC</b>			
TITLE <b>CLASH</b>			
USB3.0&EXPRESS CRAD BTB CNTR			
SIZE <b>A3</b>	CODE <b>CS</b>	DOC NUMBER <b>Model No</b>	REV <b>A02</b>
CHANGE by <b>Edi Chen</b>		8-Dec-2010	
SHEET <b>62</b>		OF <b>69</b>	

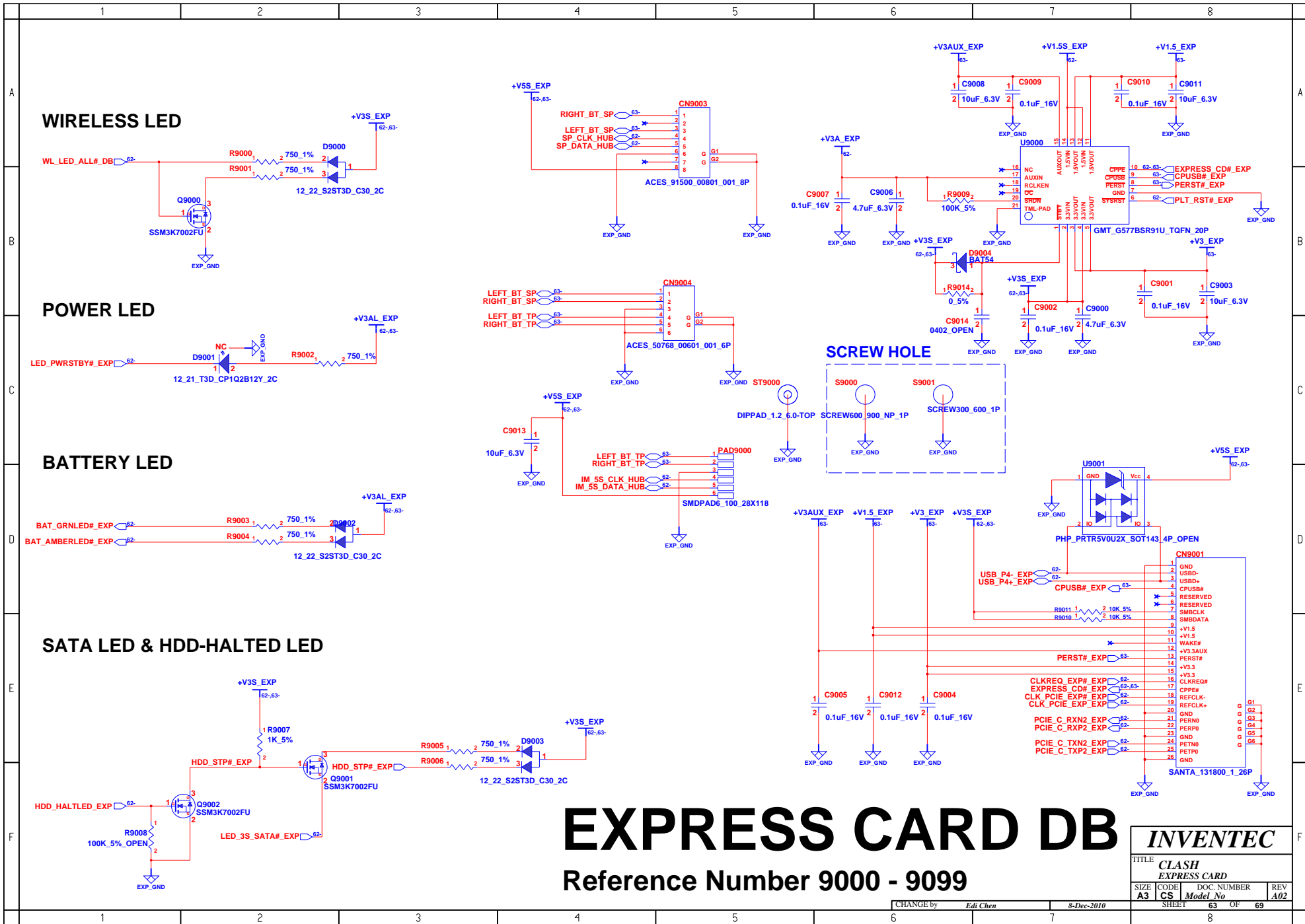

# EXPRESS CARD DB

Reference Number 9000 - 9099

<b>INVENTEC</b>			
TITLE CLASH EXPRESS CARD			
SIZE A3	CODE CS	DOC NUMBER Model No	REV A02
CHANGE by Edi Chen		8-Dec-2010	
SHEET 63		OF 69	

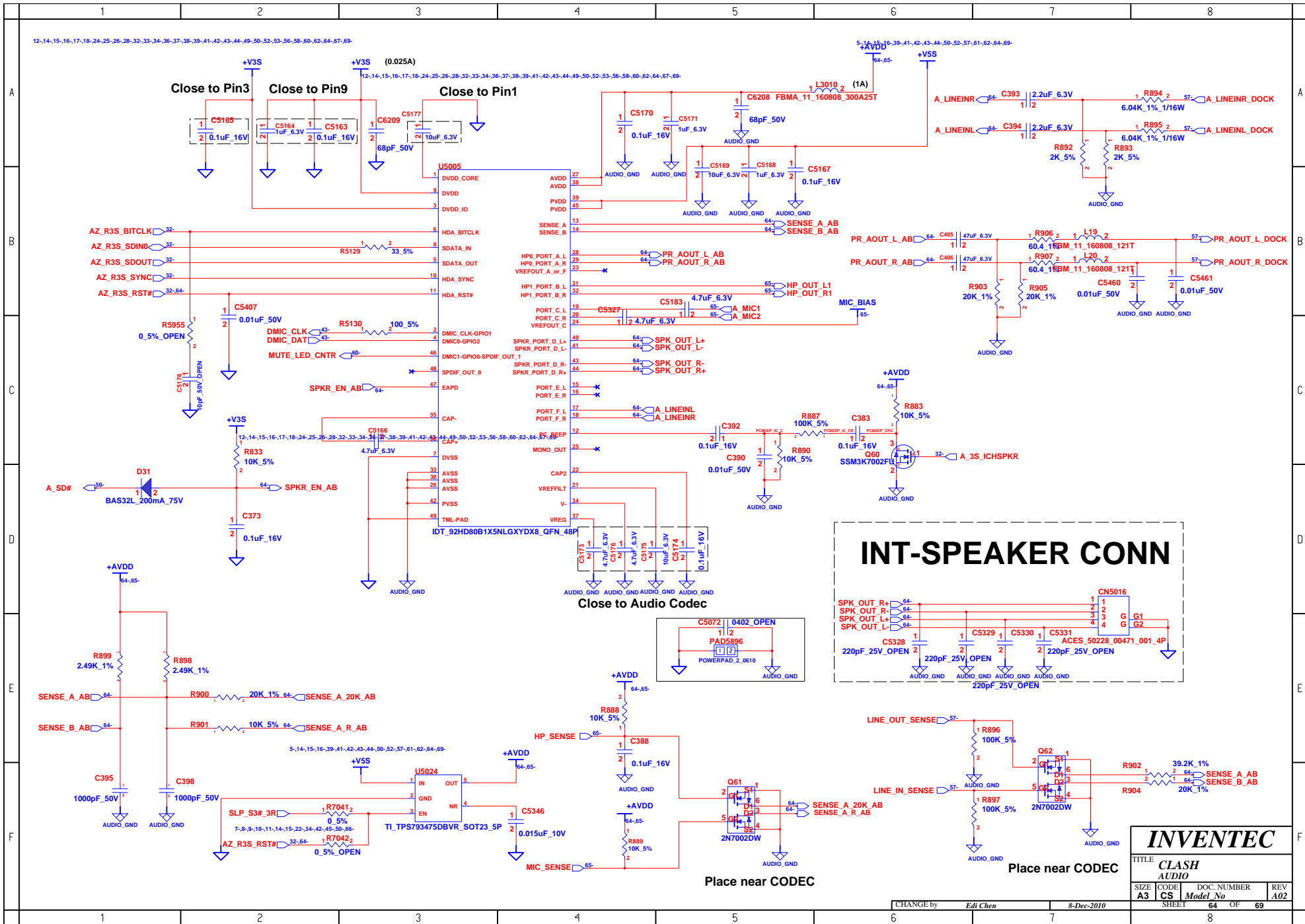



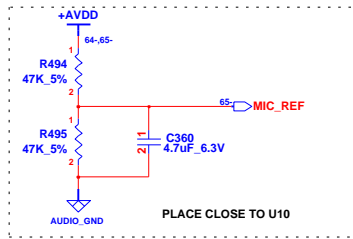
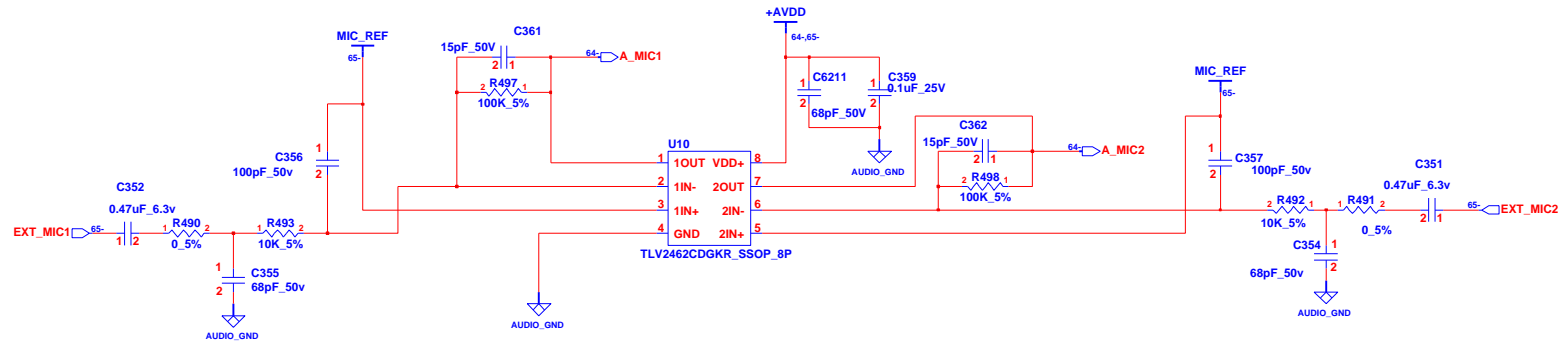

# EXT. MIC

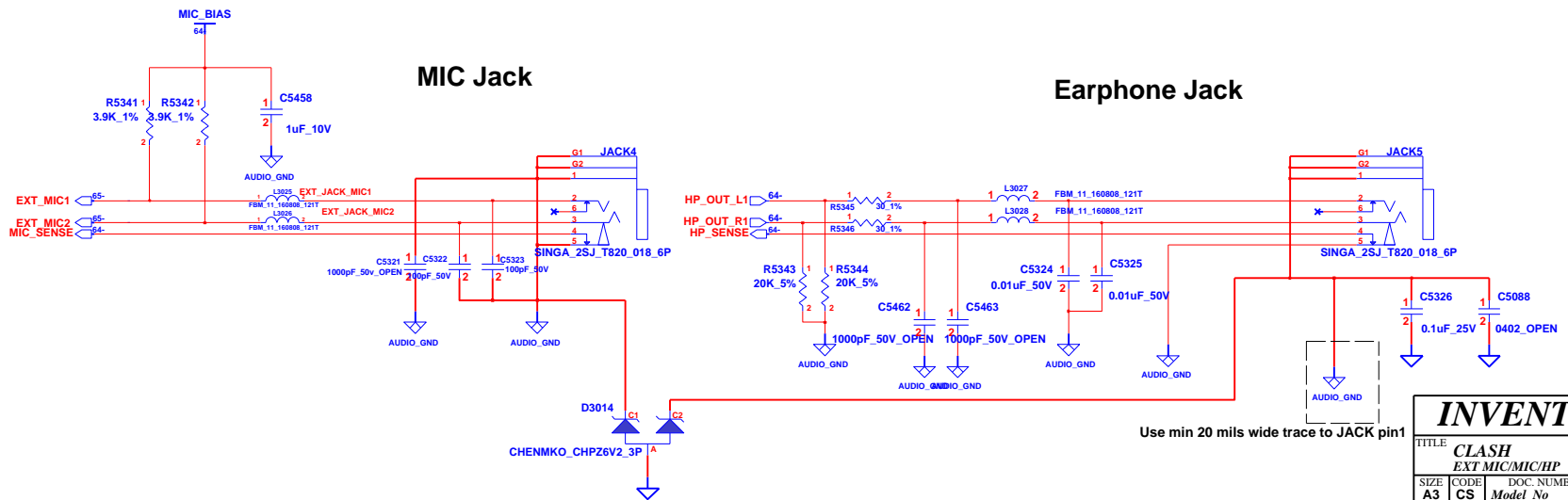

<b>INVENTEC</b>			
TITLE CLASH EXT MIC/MIC/HP			
SIZE A3	CODE CS	DOC. NUMBER Model No	REV A02
SHEET		65	OF 69

CHANGE by *Edi Chen* 8-Dec-2010

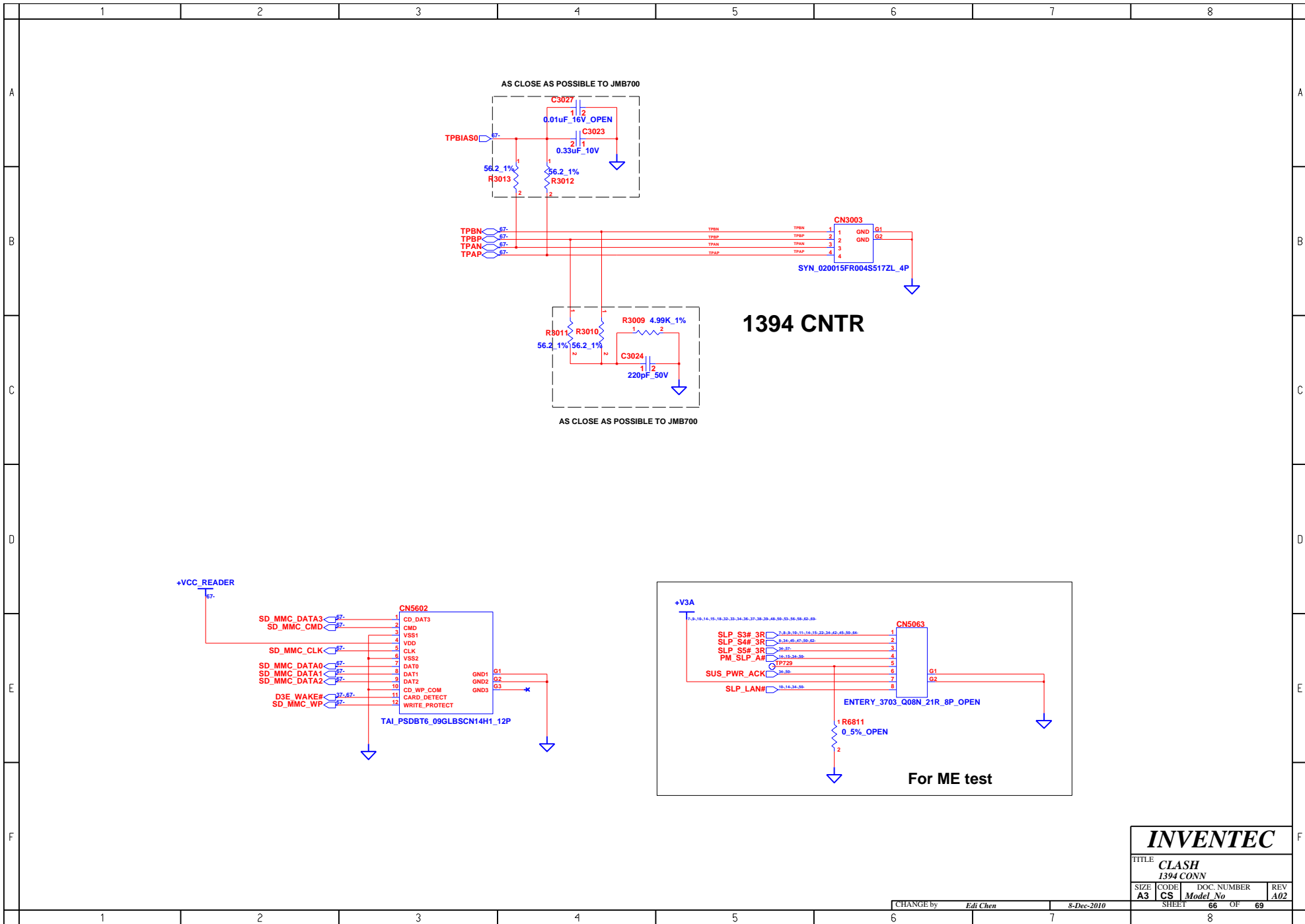

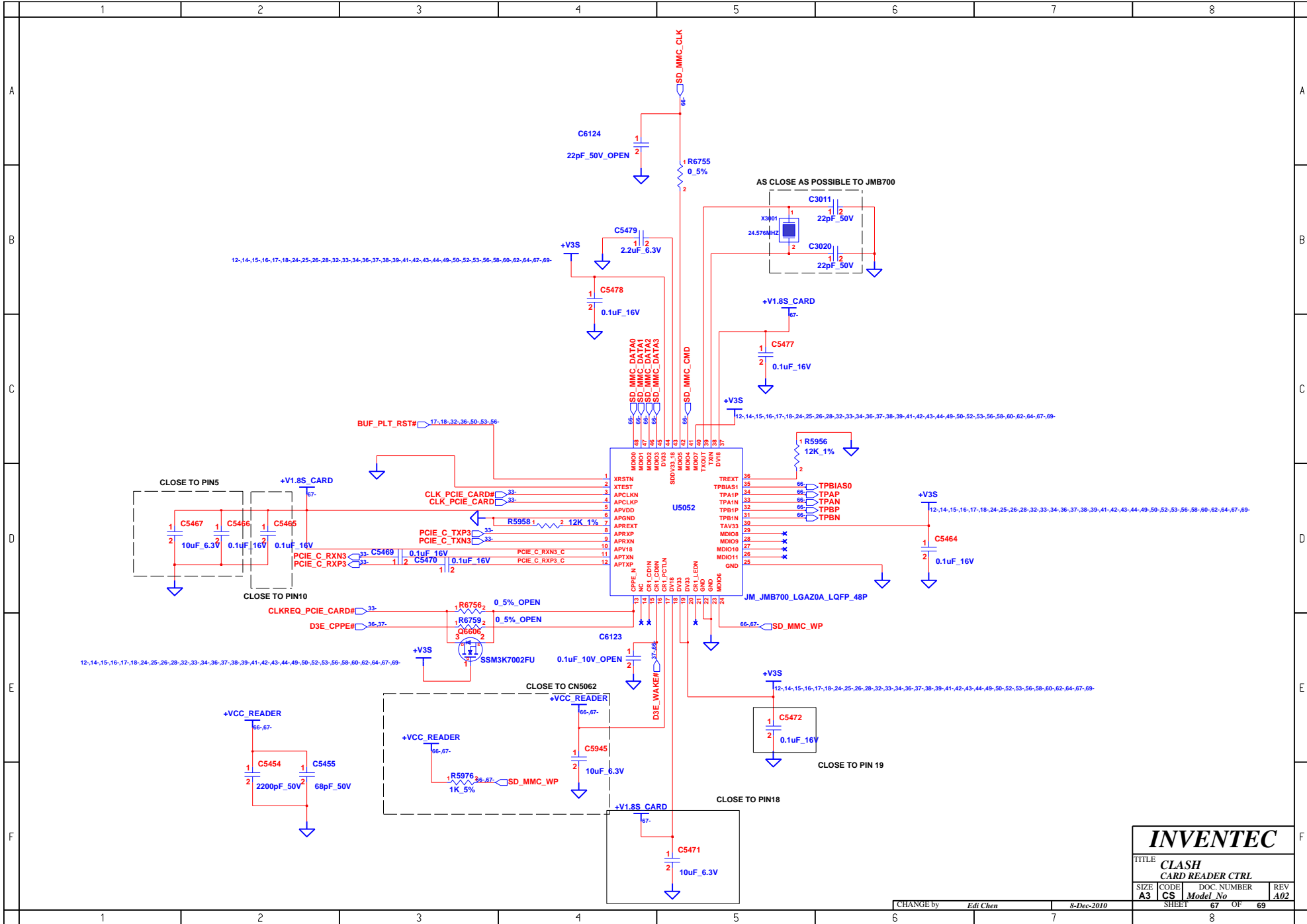

<b>INVENTEC</b>				
TITLE <b>CLASH CARD READER CTRL</b>				
SIZE <b>A3</b>	CODE <b>CS</b>	DOC NUMBER <i>Model No</i>	REV <b>A02</b>	
CHANGE by <i>Edi Chen</i>		8-Dec-2010		SHEET <b>67</b> OF <b>69</b>

<http://sualaptop365.edu.vn>

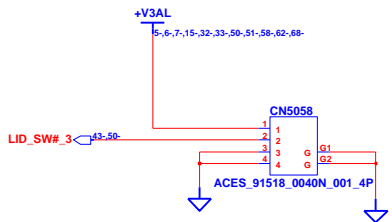
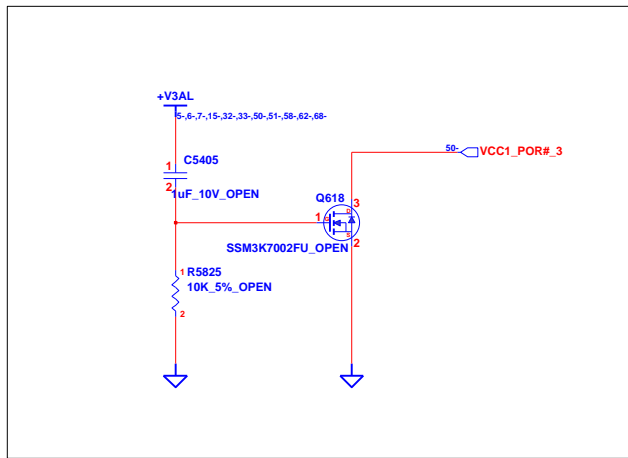
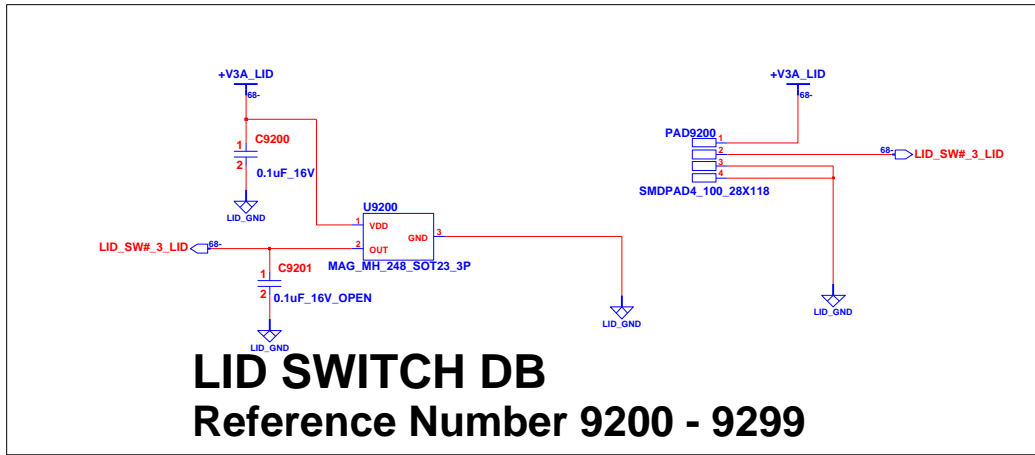

**INVENTEC**

TITLE			
CLASH			
LID SWITCH			
SIZE	CODE	DOC. NUMBER	REV
A3	CS	Model No	A02

CHANGE by *Edi Chen* 8-Dec-2010

SHEET 68 OF 69

