

1	2	3	4	5	6	7	8
---	---	---	---	---	---	---	---

THIS DRAWING AND SPECIFICATIONS, HEREIN, ARE THE PROPERTY OF INVENTEC CORPORATION AND SHALL NOT BE REPRODUCED, COPIED, OR USED IN WHOLE OR IN PART AS THE BASIS FOR THE MANUFACTURE OR SALE OF ITEMS WITHOUT WRITTEN PERMISSION, INVENTEC CORPORATION 2009 ALL RIGHT RESERVED

A

A

B

B

C

C

D

D

E

E

VULCAIN UMA

MV Build

2009.04.17

DATE	CHANGE NO.	REV

DRAWER	EE	DATE	POWER	DATE	INVENTEC
DESIGN					
CHECK					
RESPONSIBLE					
TITLE					VULCAIN UMA
SIZE =	3	VER :			SIZE CODE
FILE NAME :	XXXX XXXXXX-XX				A3 CS
P/N	XXXXXXXXXXXX				DOC. NUMBER
					1310A22565-0-MTR
					REV
					A02
					SHEET
					1 OF 50

1	2	3	4	5	6	7	8
---	---	---	---	---	---	---	---

TABLE OF CONTENTS

PAGE

- 5- DC& BATTERY CHARGER
- 6- SELECT & BATTERY CONN
- 7- SYSTEM POWER(3V/5V)
- 8- SYSTEM POWER(+V1.8/+V1.25S)
- 9- SYSTEM POWER(+VGFX/+VCCP)
- 10- SYSTEM POWER(+V1.5S)
- 11- CPU POWER(VCC_CORE)
- 12- DDR TERMINATION VOLTAGE
- 13- POWER(SLEEP)
- 14- POWER(SEQUENCE)

PAGE

- 15- CLOCK_GENERATOR
- 16- PENRYN-1
- 17- PENRYN-2
- 18- PENRYN-3
- 19- THERMAL&FAN CONTROLLER
- 20- Crestline-1
- 21- Crestline-2
- 22- Crestline-3
- 23- Crestline-4
- 24- Crestline-5
- 25- Crestline-6
- 26- DDR2-DIMM0
- 27- DDR2-DIMM1
- 28- DDR2-DAMPING
- 29- VGA CONN
- 30- LCM CONN
- 31- ICH8-1
- 32- ICH8-2
- 33- ICH8-3
- 34- ICH8-4
- 35- ICH8-5

PAGE

- 36- SYSTEM BIOS
- 37- HDD&ODD CONN
- 38- USB CONN
- 39- KBC
- 40- KB&TP CONN
- 41- AUDIO CODEC
- 42- MDC CONN & AUDIO JACK
- 43- NIC 10/100- CONTROLLER
- 44- NIC 10/100- RJ45 CONN
- 45- MINICARD & BT CONN
- 46- NEW CARD & SD/MMC
- 47- LED & BUTTON&LID SWITCH
- 48- SCREW HOLE
- 49- SWITCH Board
- 50- ODD Extend Board

INVENTEC

TITLE *Vulcain UMA*

SIZE	CODE	DOC. NUMBER	REV
D	CS	AXI	000
SHEET		2 OF	50

CHANGE by *Puma Chen* 26-Dec-2008

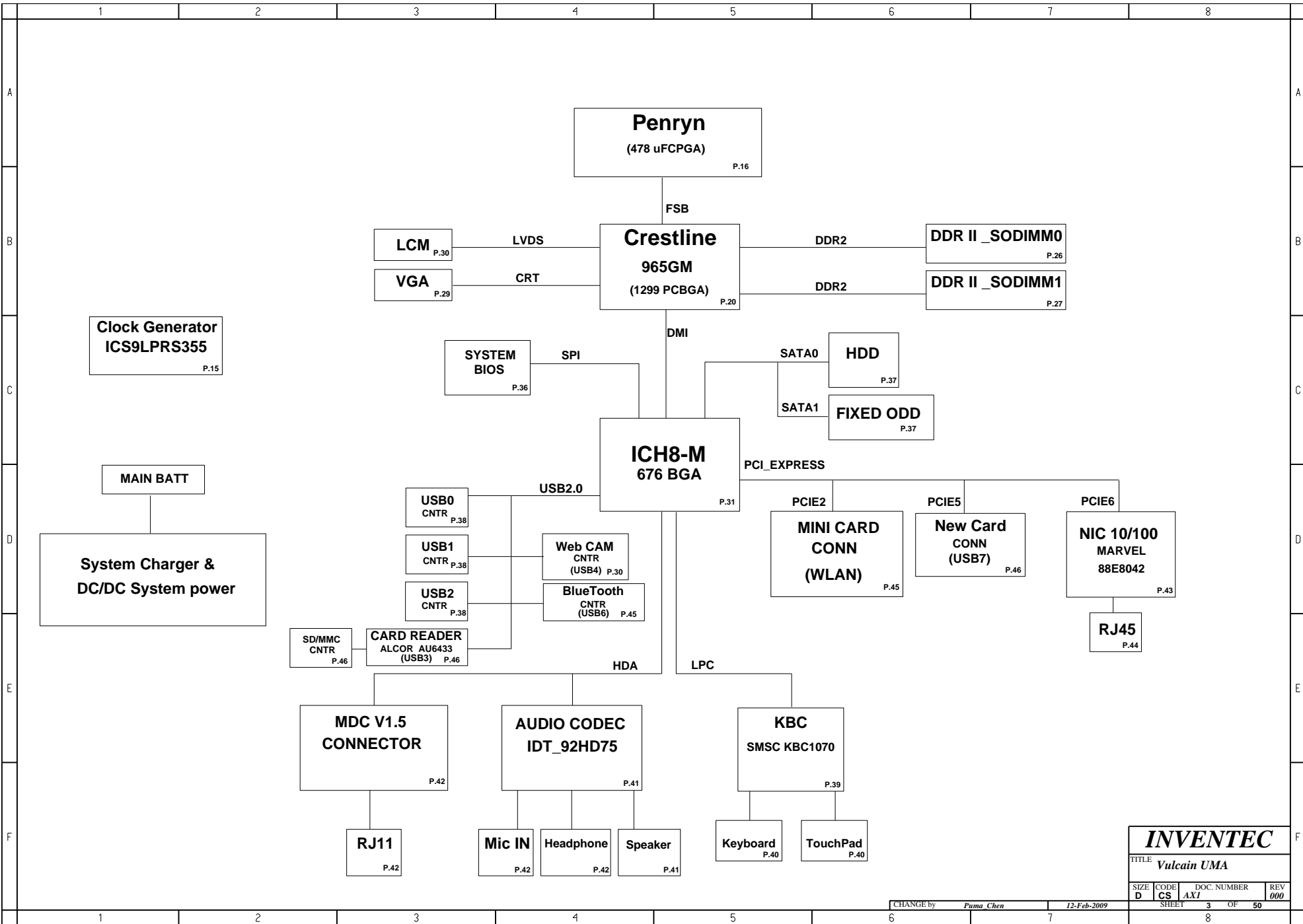

INVENTEC			
TITLE <i>Vulcain UMA</i>			
SIZE	CODE	DOC. NUMBER	REV
D	CS	AX1	000
CHANGE by <i>Puma Chen</i> 12-Feb-2009			SHEET 3 OF 50
			8

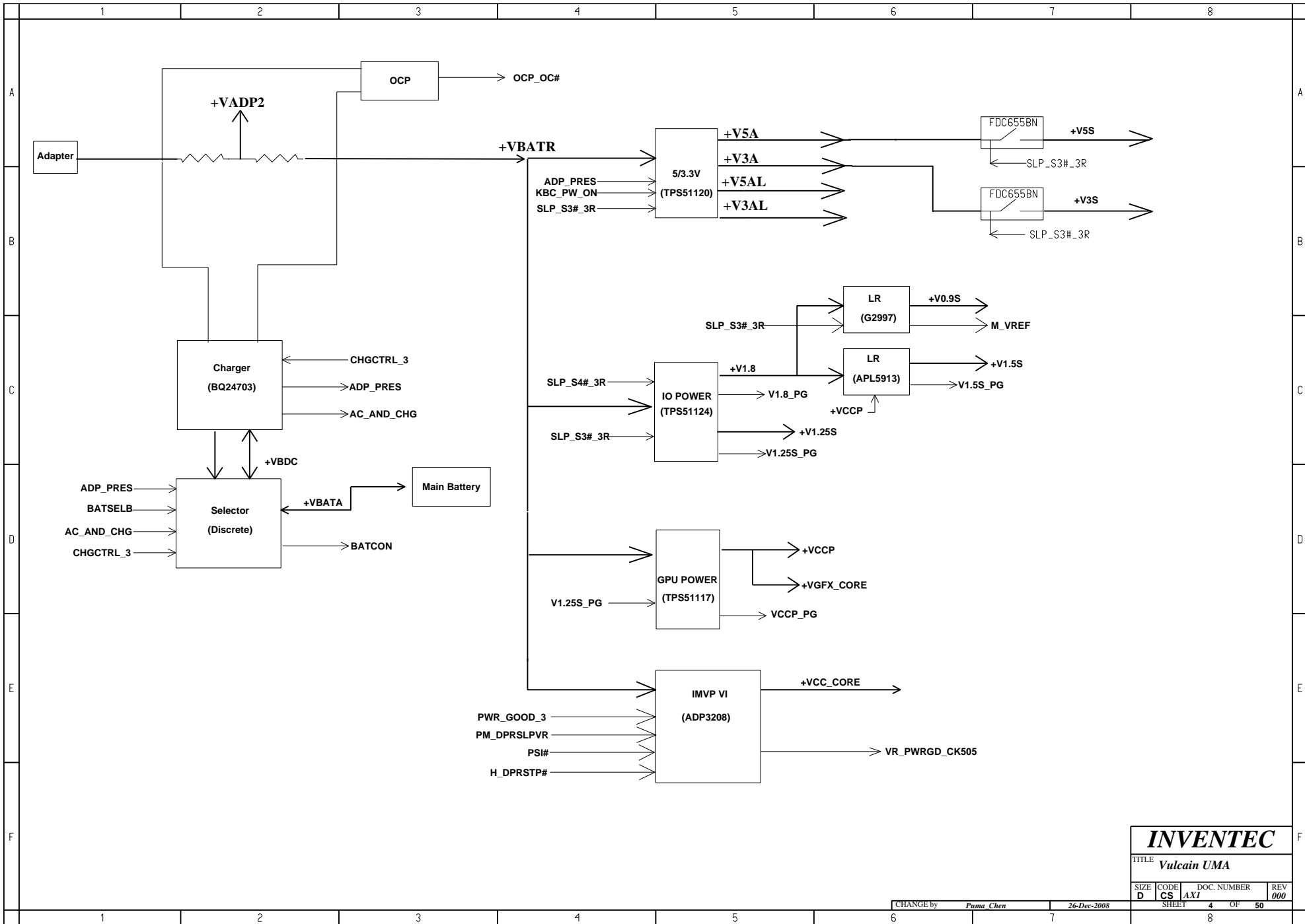

INVENTEC

TITLE **Vulcain UMA**

SIZE	CODE	DOC. NUMBER	REV
D	CS	AXI	000

CHANGE by	Puma Chen	26-Dec-2008	SHEET	4	OF	50
			SHEET	8		

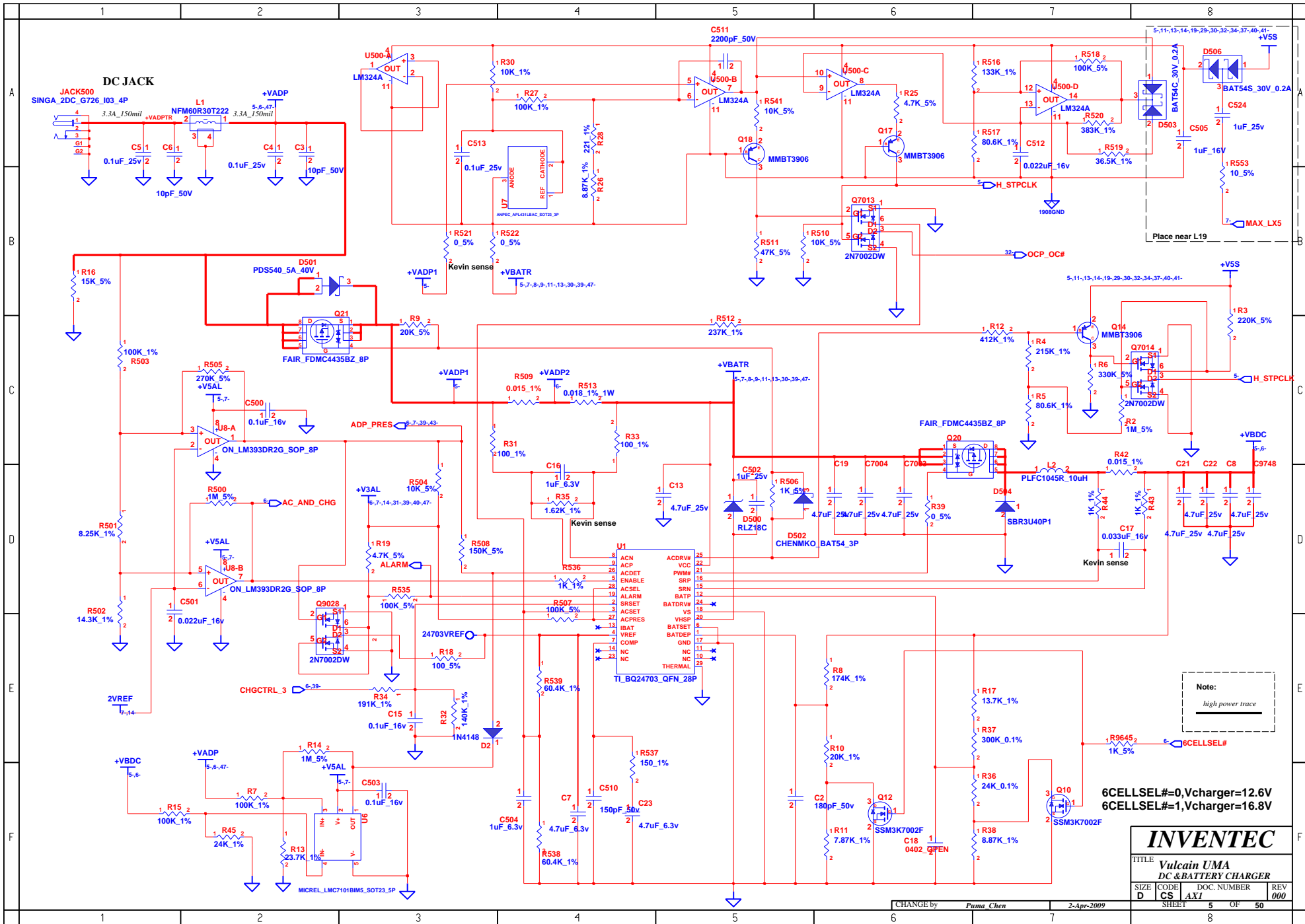

Note:
 high power trace

6CELLSEL#=0, Vcharger=12.6V
 6CELLSEL#=1, Vcharger=16.8V

INVENTEC			
TITLE Vulcain UMA DC & BATTERY CHARGER			
SIZE	CODE	DOC. NUMBER	REV
D	CS	AX1	000
SHEET		5	OF 50

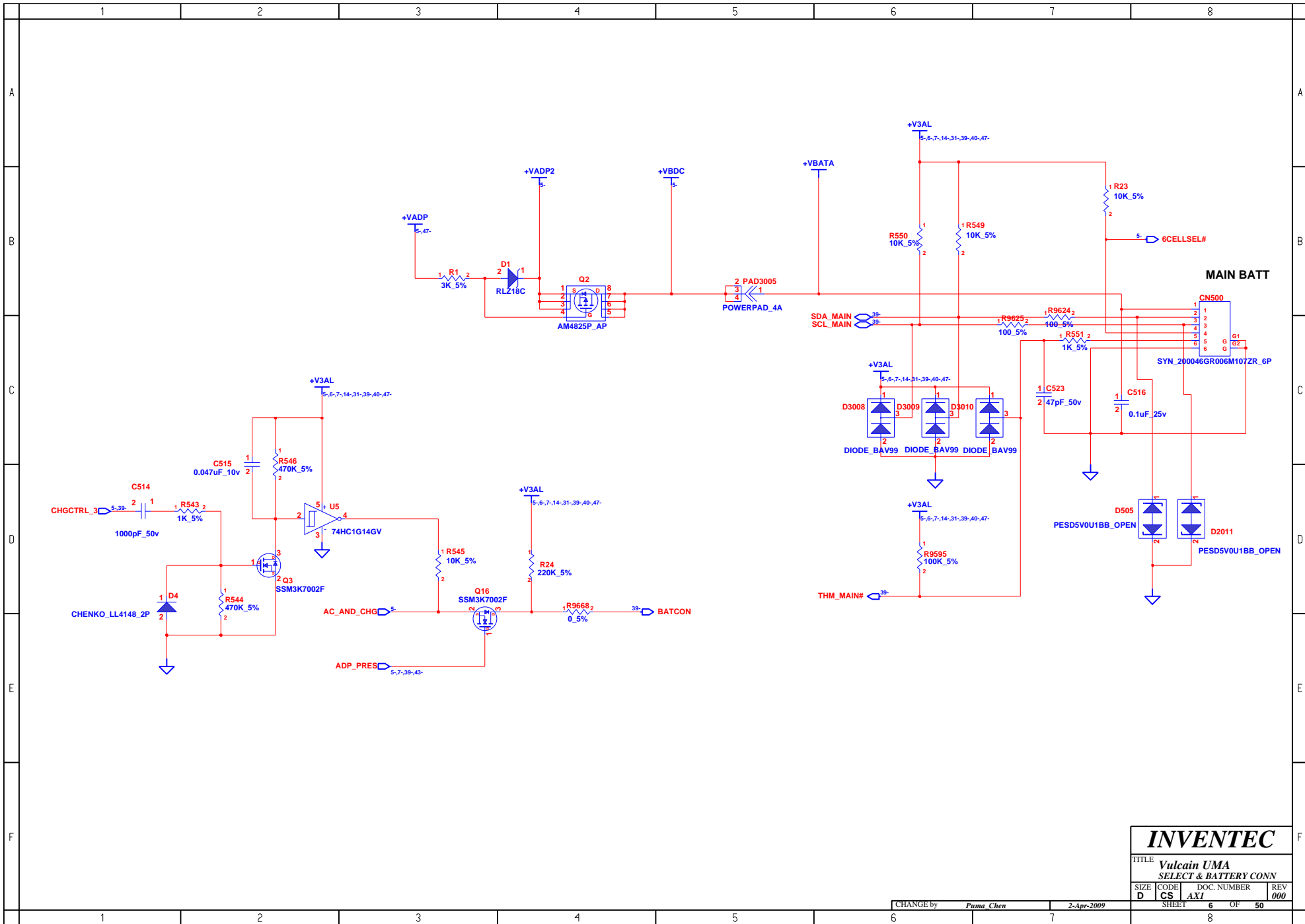

INVENTEC

TITLE
**Vulcain UMA
 SELECT & BATTERY CONN**

SIZE D	CODE CS	DOC. NUMBER AXI	REV 000
CHANGE by <i>Puma Chen</i>		2-Apr-2009	
SHEET		6	OF 50

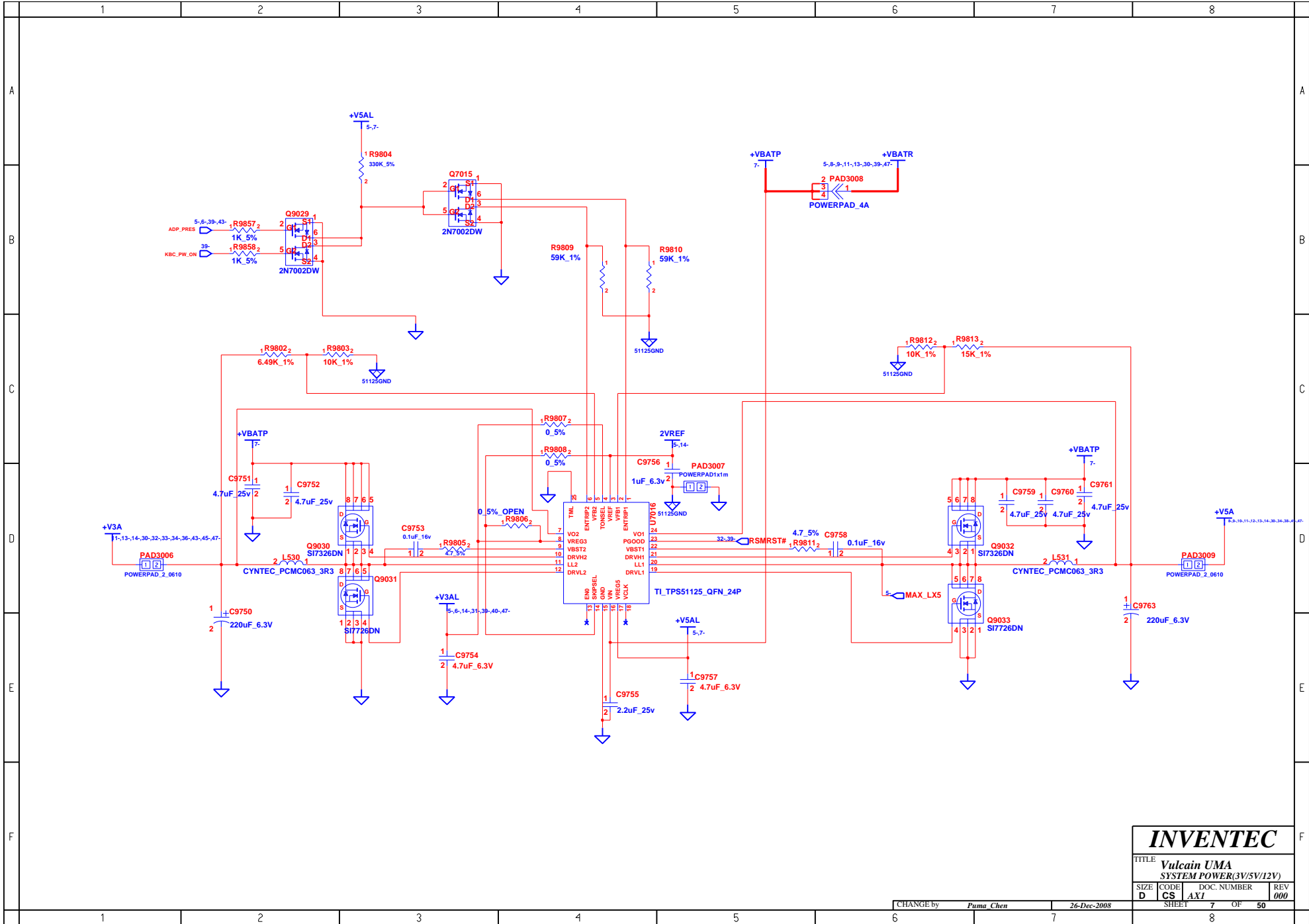

INVENTEC			
TITLE Vulcain UMA SYSTEM POWER(3V/5V/12V)			
SIZE D	CODE CS	DOC. NUMBER AXI	REV 000
CHANGE by Puma Chen		26-Dec-2008	
SHEET 7		OF 50	

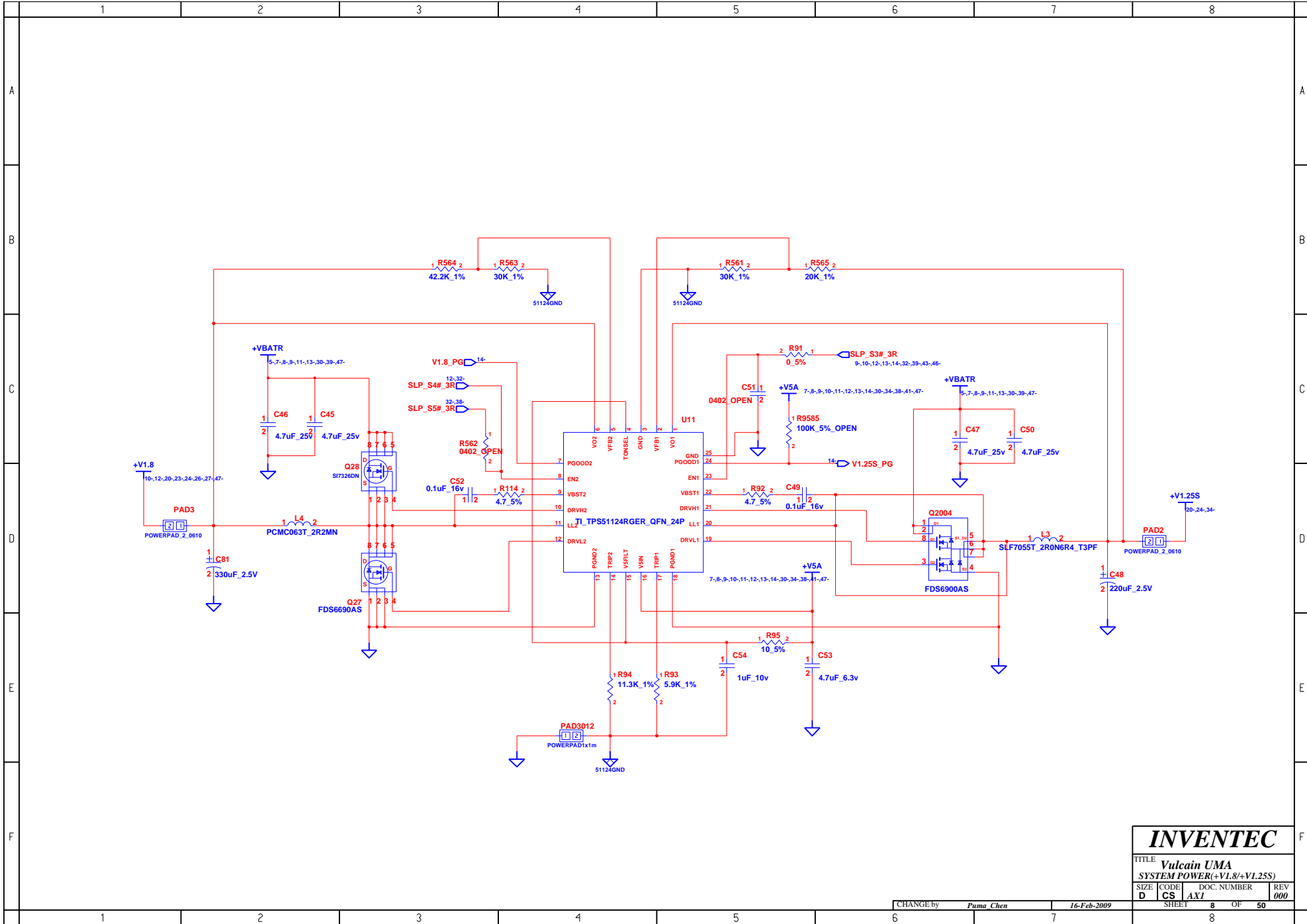

INVENTEC			
TITLE Vulcain UMA			
SYSTEM POWER(+V1.8/+V1.25S)			
SIZE	CODE	DOC. NUMBER	REV
D	CS	AX1	000
CHANGE by <i>Puma Chen</i>		16-Feb-2009	
SHEET		8 OF 50	

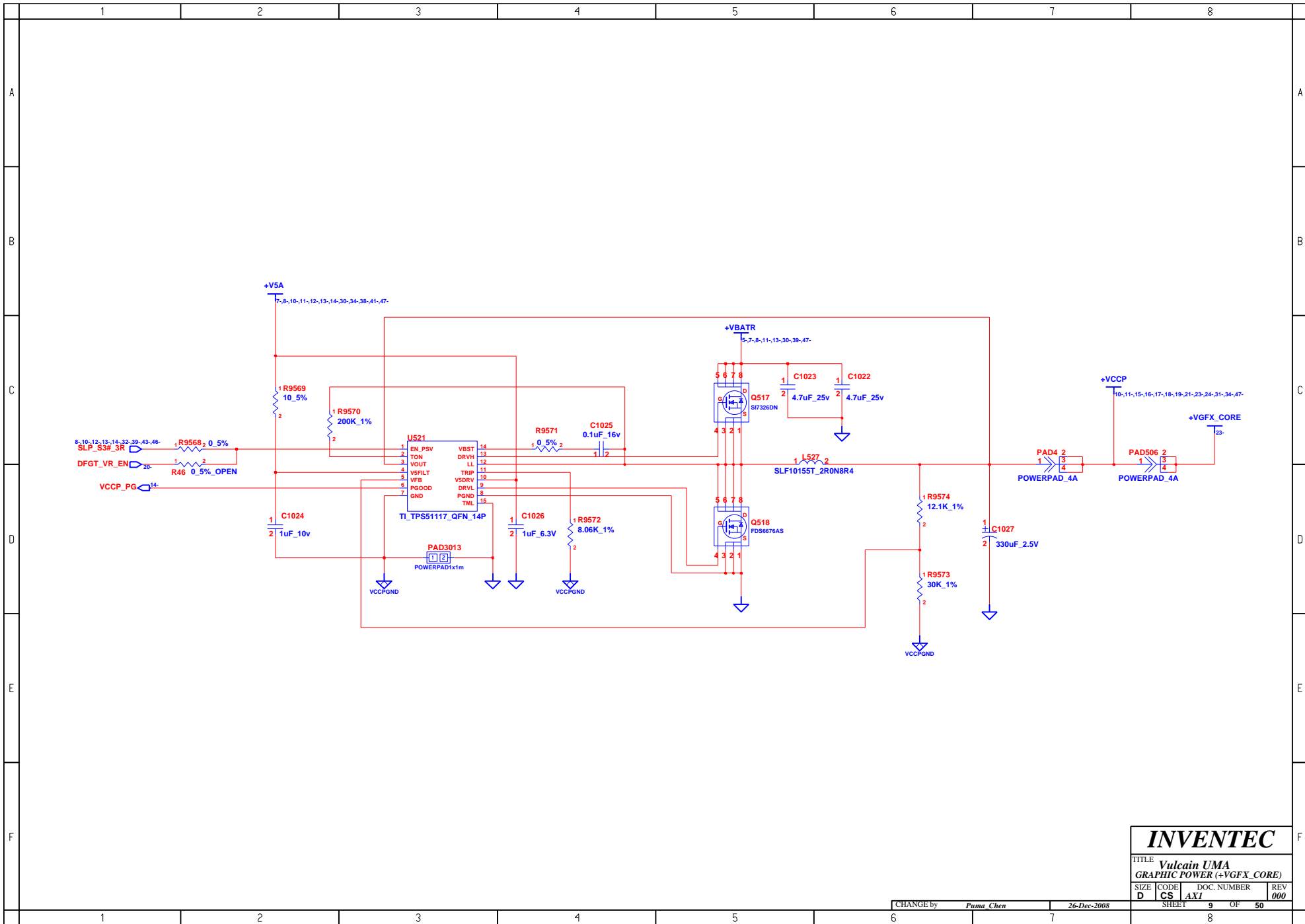

INVENTEC

TITLE **Vulcain UMA**
GRAPHIC POWER (+VGFX_CORE)

SIZE	CODE	DOC. NUMBER	REV
D	CS	AX1	000

CHANGE by *Puma Chen* 26-Dec-2008

SHEET 9 OF 50

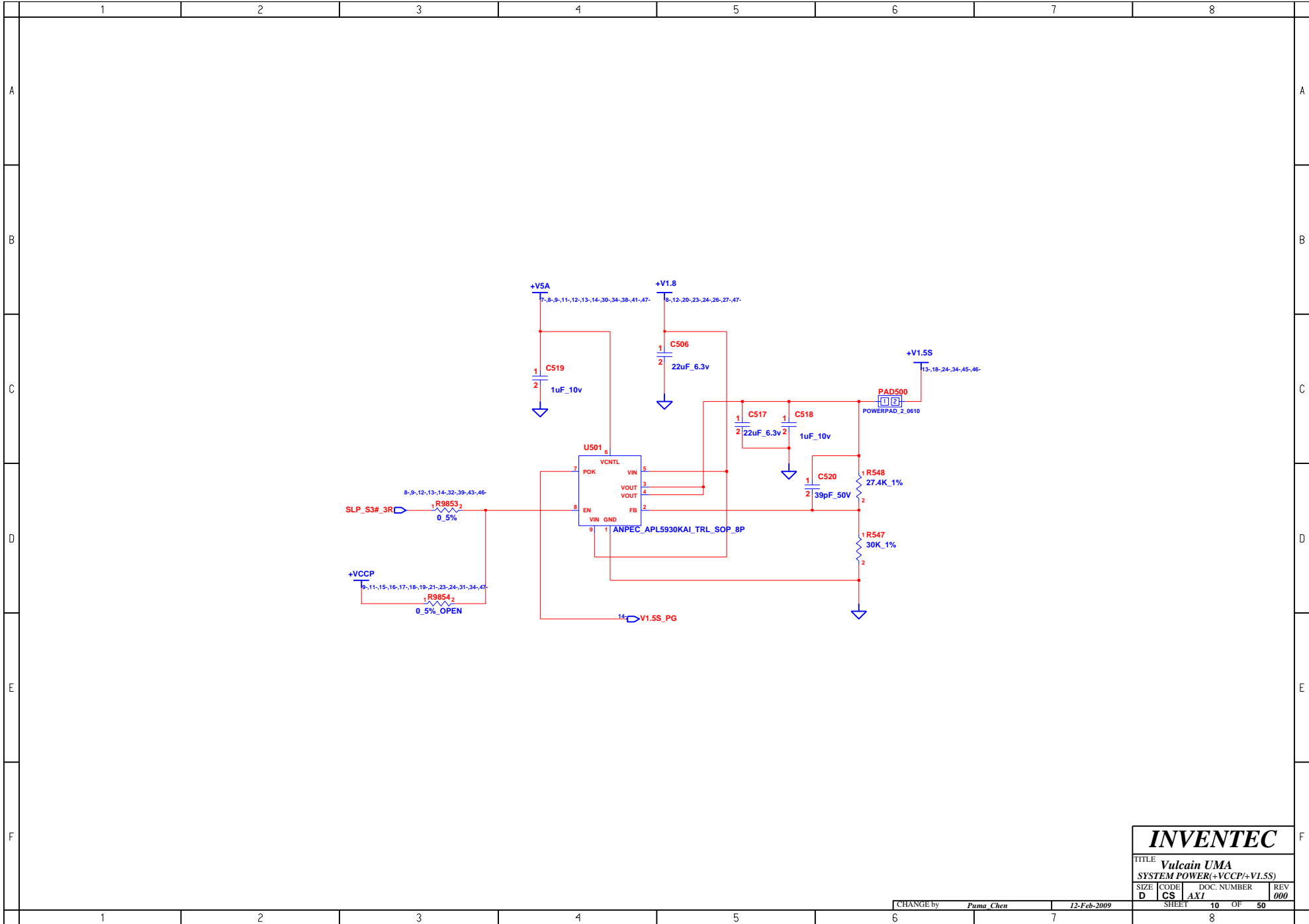

INVENTEC

TITLE **Vulcain UMA**
SYSTEM POWER(+VCCP/+V1.5S)

SIZE	CODE	DOC. NUMBER	REV
D	CS	AXI	000

CHANGE by *Puma Chen* 12-Feb-2009

SHEET 10 OF 50

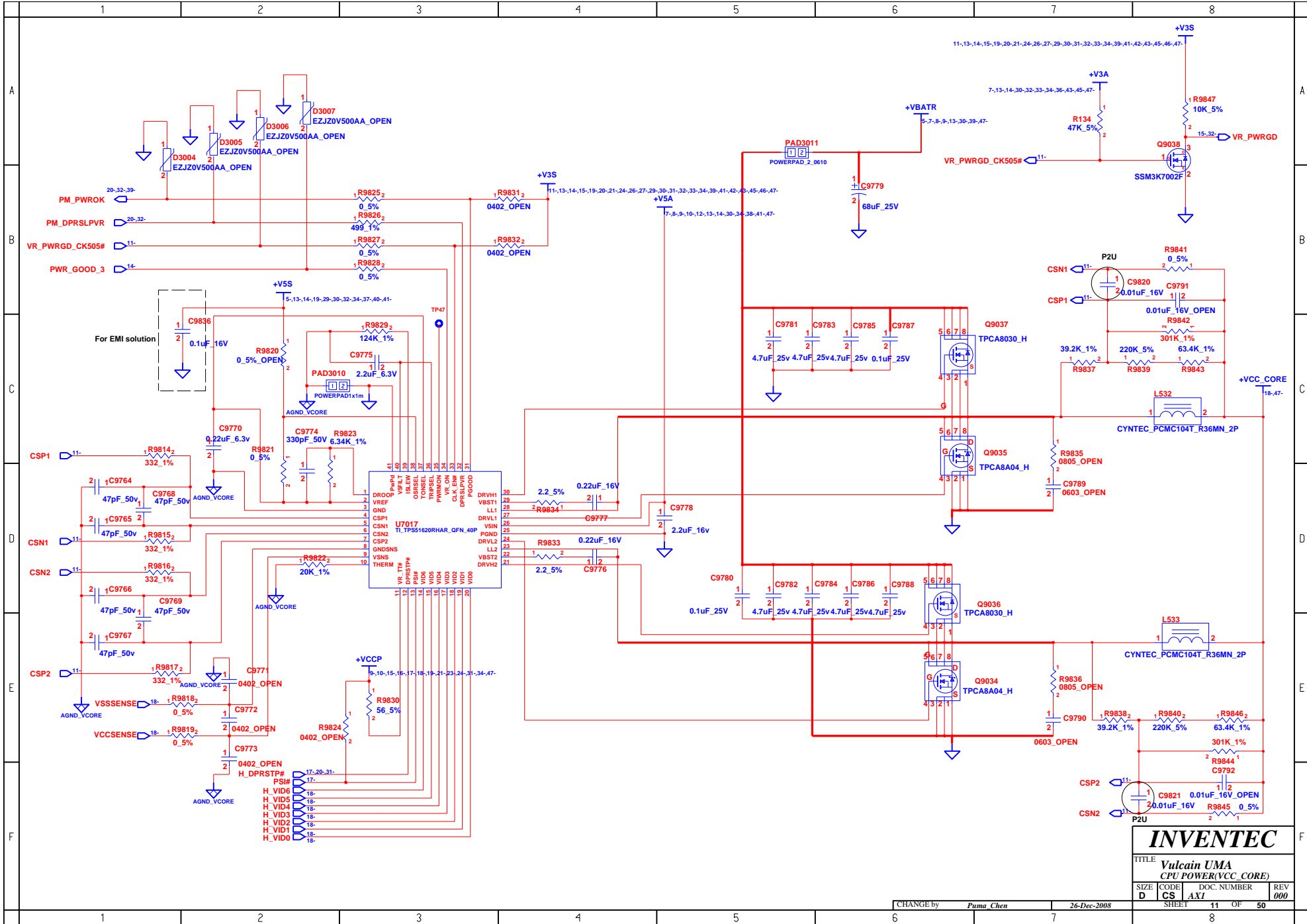

INVENTEC			
TITLE Vulcain UMA CPU POWER(VCC_CORE)			
SIZE D	CODE CS	DOC. NUMBER AX1	REV 000
CHANGE by Puma Chen		26-Dec-2008	
SHEET 11		OF 50	

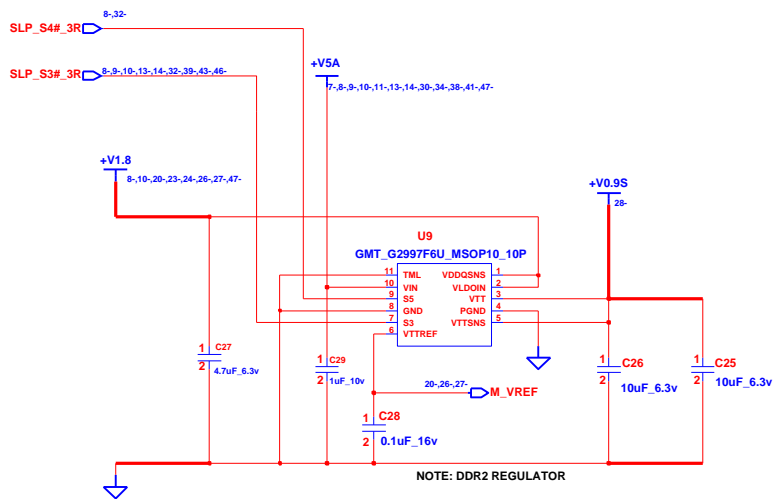

INVENTEC

TITLE **Vulcain UMA
DDR TERMINATION VOLTAGE**

SIZE D	CODE CS	DOC. NUMBER AXI	REV 000
------------------	-------------------	---------------------------	-------------------

CHANGE by *Pama Chen* 26-Dec-2008

SHEET 12 OF 50

	1	2	3	4	5	6	7	8	
A									
B									
C									
D									
E									
F									
	1	2	3	4	5	6	7	8	

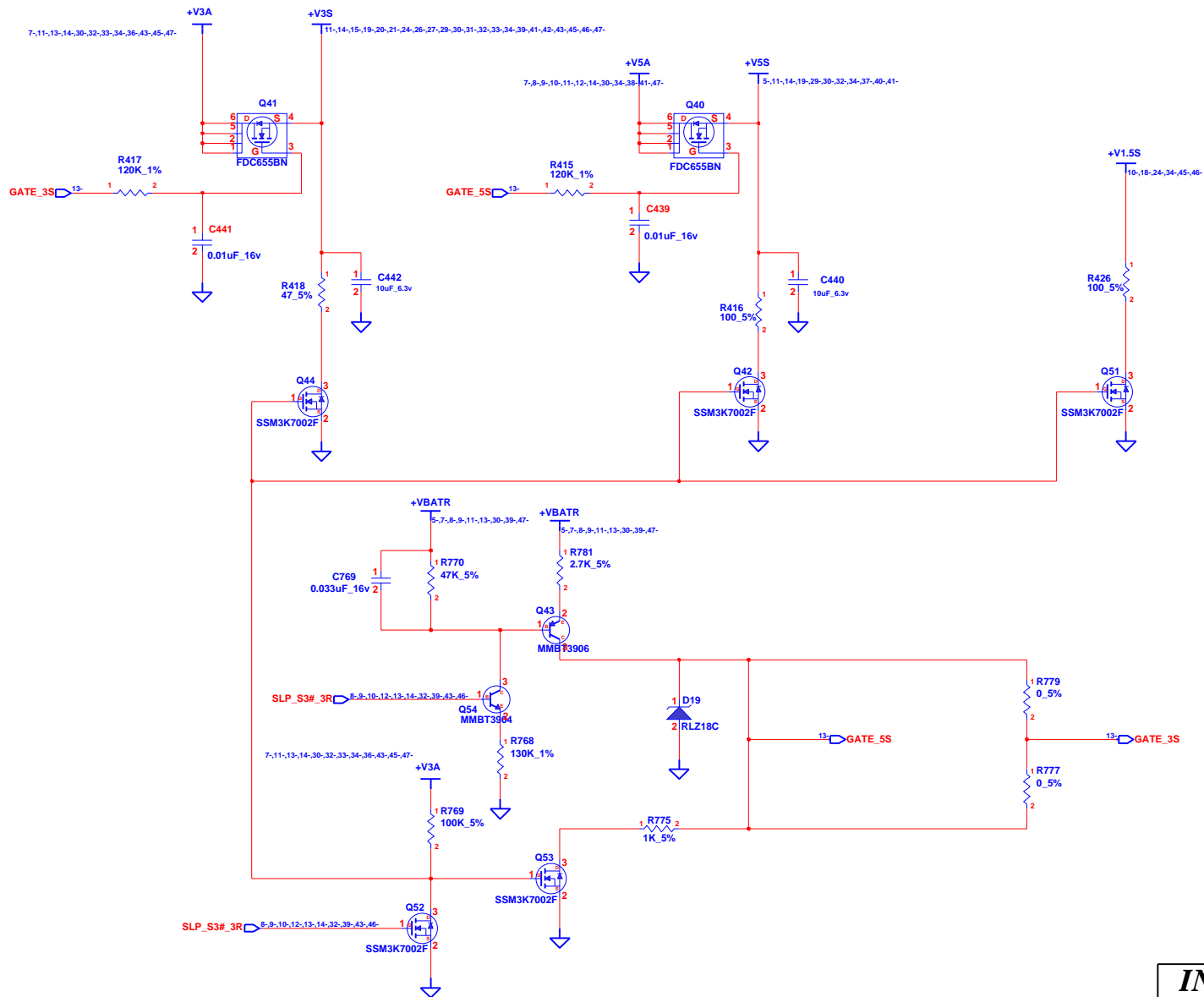

INVENTEC

TITLE			
Vulcain UMA POWER(SLEEP)			
SIZE	CODE	DOC. NUMBER	REV
D	CS	AXI	000

CHANGE by Puma Chen 26-Dec-2008

SHEET 13 OF 50

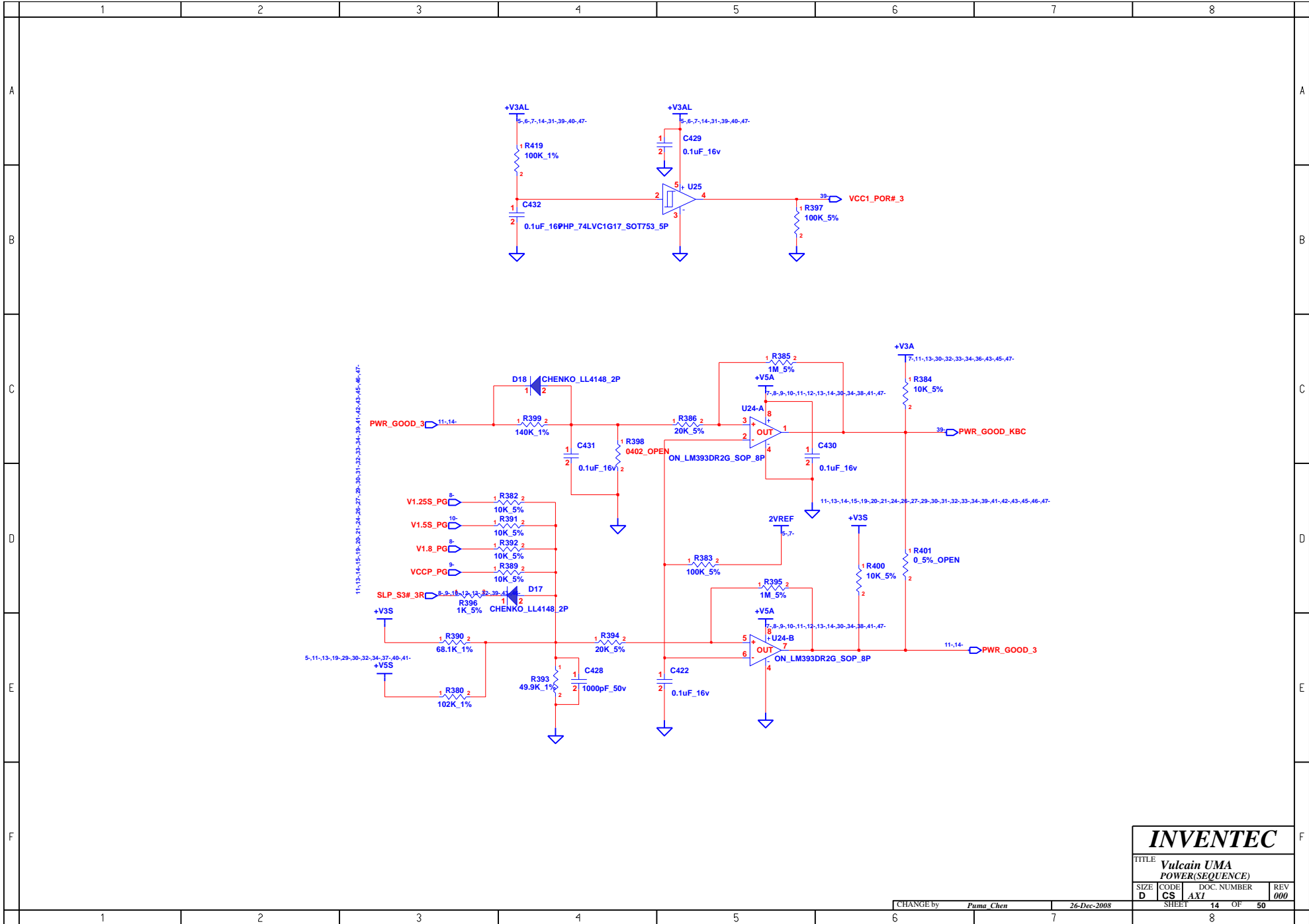

INVENTEC

TITLE			
Vulcain UMA POWER(SEQUENCE)			
SIZE	CODE	DOC. NUMBER	REV
D	CS	AXI	000
CHANGE by		SHEET	
Puma Chen		14 OF 50	

26-Dec-2008

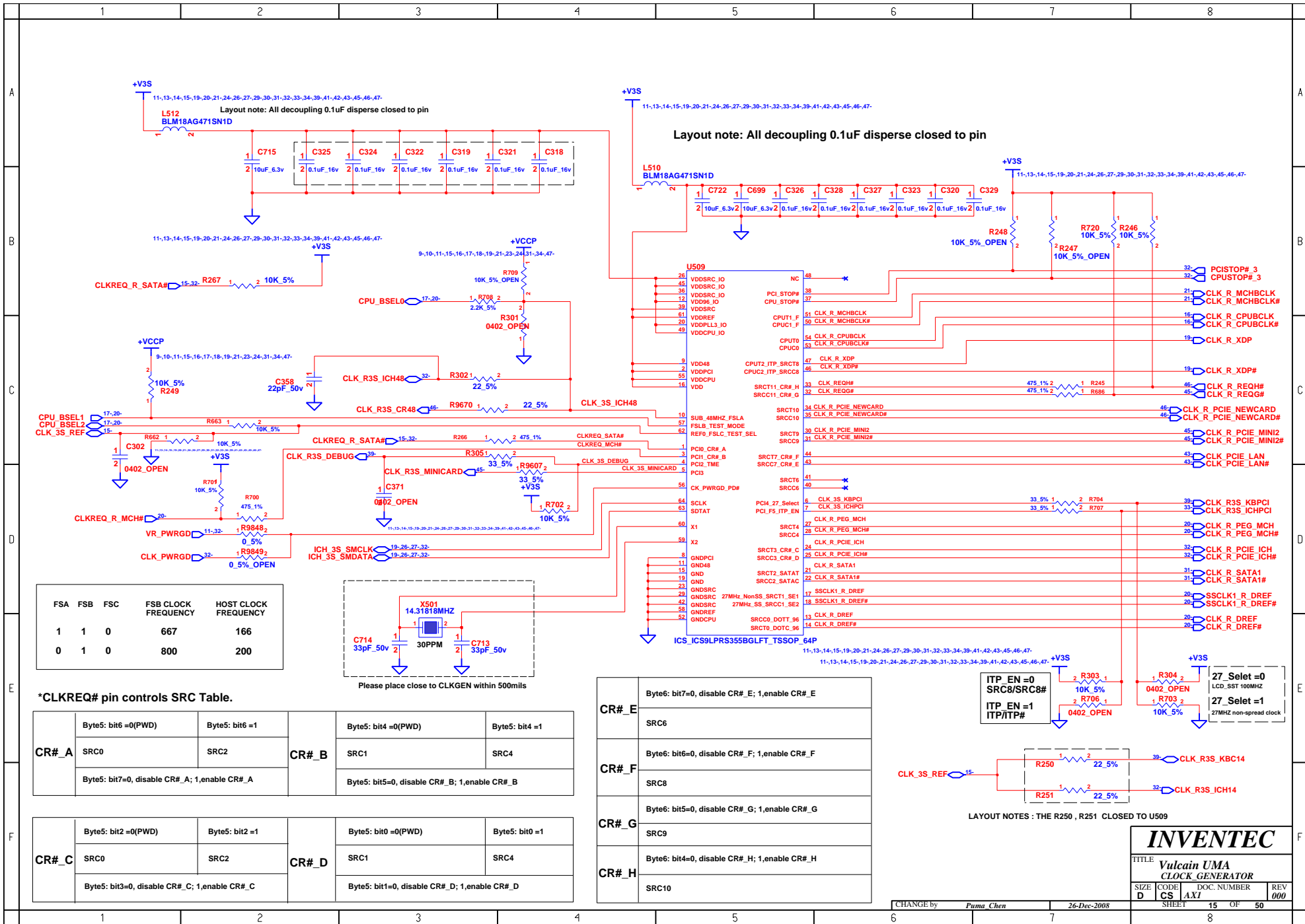

Layout note: All decoupling 0.1uF disperse closed to pin

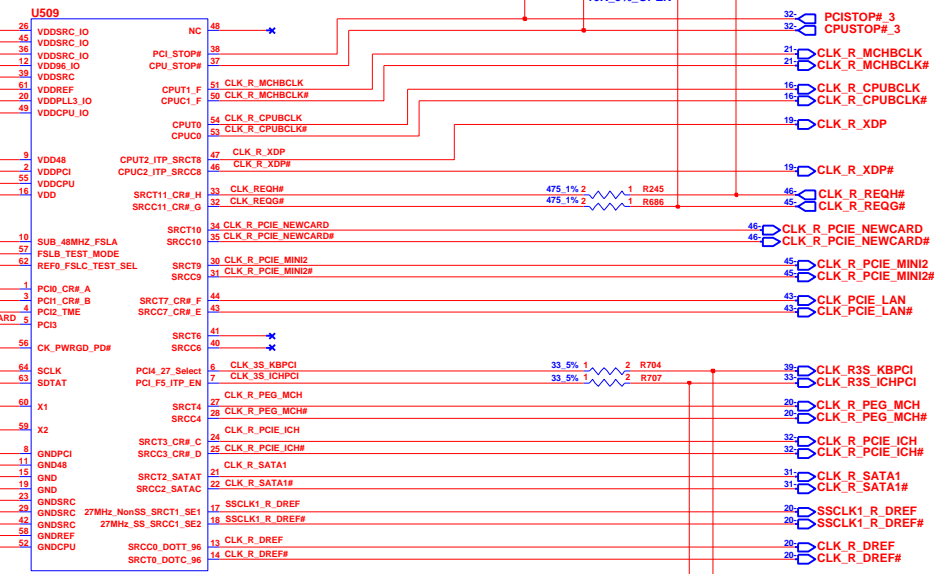

FSA	FSB	FSC	FSB CLOCK FREQUENCY	HOST CLOCK FREQUENCY
1	1	0	667	166
0	1	0	800	200

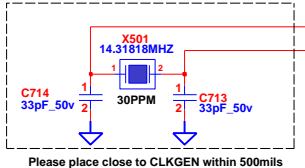

*CLKREQ# pin controls SRC Table.

CR#_A	Byte5: bit6 =0(PWD)		Byte5: bit6 =1		CR#_B	Byte5: bit4 =0(PWD)		Byte5: bit4 =1	
	SRC0	SRC2	SRC1	SRC4		SRC1	SRC4	SRC1	SRC4
Byte5: bit7=0, disable CR#_A; 1,enable CR#_A		Byte5: bit5=0, disable CR#_B; 1,enable CR#_B		Byte5: bit0 =0(PWD)		Byte5: bit0 =1		Byte5: bit1=0, disable CR#_D; 1,enable CR#_D	
CR#_C	Byte5: bit2 =0(PWD)		Byte5: bit2 =1		CR#_D	Byte5: bit0 =0(PWD)		Byte5: bit0 =1	
	SRC0	SRC2	SRC1	SRC4		SRC1	SRC4	SRC1	SRC4
Byte5: bit3=0, disable CR#_C; 1,enable CR#_C		Byte5: bit1=0, disable CR#_D; 1,enable CR#_D		Byte5: bit0 =0(PWD)		Byte5: bit0 =1		Byte5: bit1=0, disable CR#_D; 1,enable CR#_D	

CR#_E	Byte6: bit7=0, disable CR#_E; 1,enable CR#_E	SRC6
CR#_F	Byte6: bit6=0, disable CR#_F; 1,enable CR#_F	SRC8
CR#_G	Byte6: bit5=0, disable CR#_G; 1,enable CR#_G	SRC9
CR#_H	Byte6: bit4=0, disable CR#_H; 1,enable CR#_H	SRC10

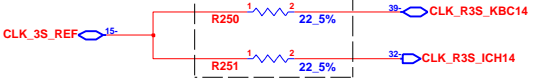
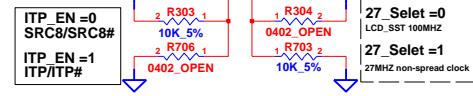

LAYOUT NOTES : THE R250 , R251 CLOSED TO U509

INVENTEC

TITLE: Vulcain UMA
CLOCK GENERATOR

SIZE D CODE CS AXI DOC NUMBER REV 000

SHEET 15 OF 50

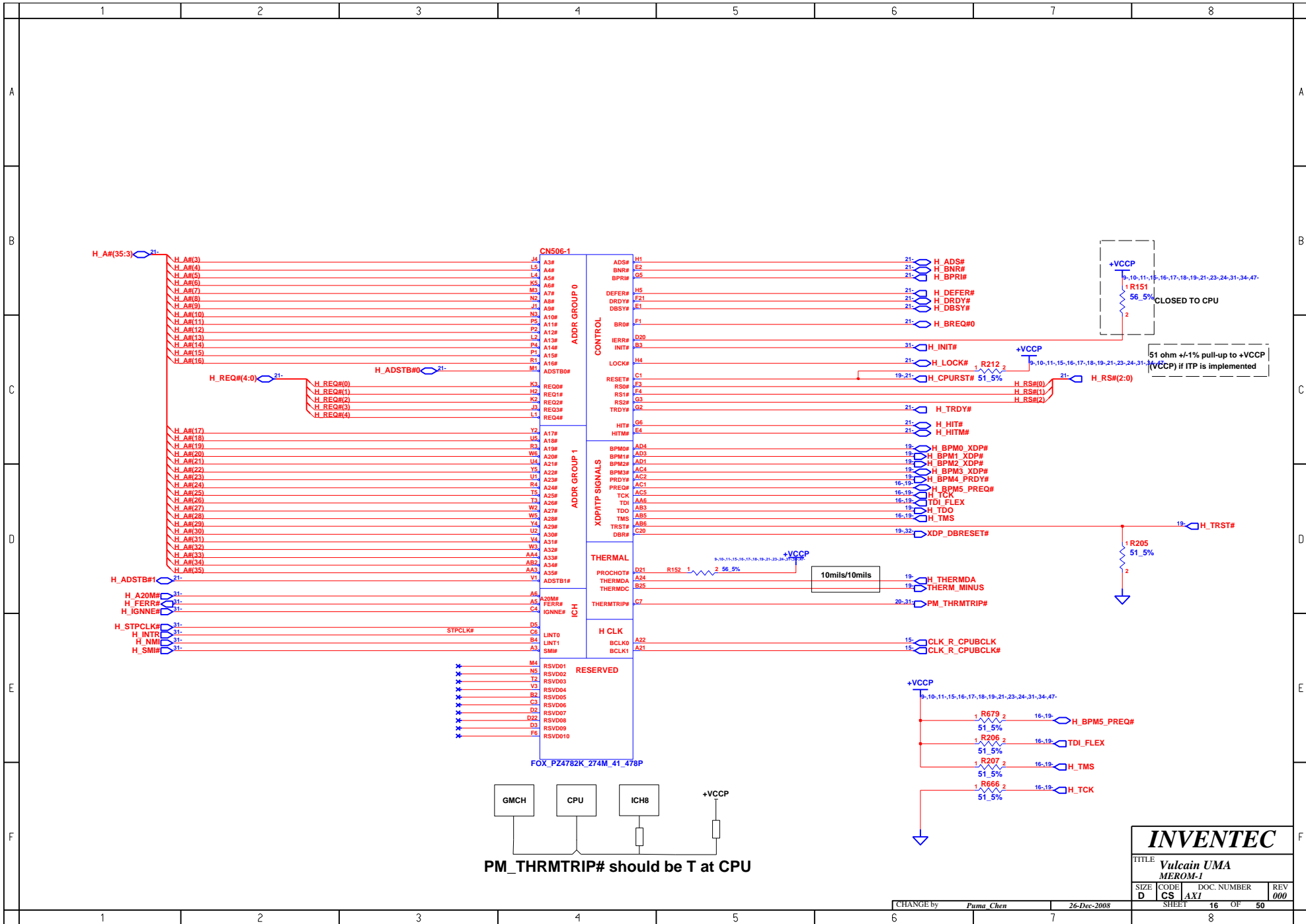

PM_THRMTRIP# should be T at CPU

INVENTEC			
TITLE: Vulcain UMA MEROM-1			
SIZE: D	CODE: CS AXI	DOC. NUMBER:	REV: 000
CHANGE by: Puma Chen		26-Dec-2008	SHEET: 16 OF 50

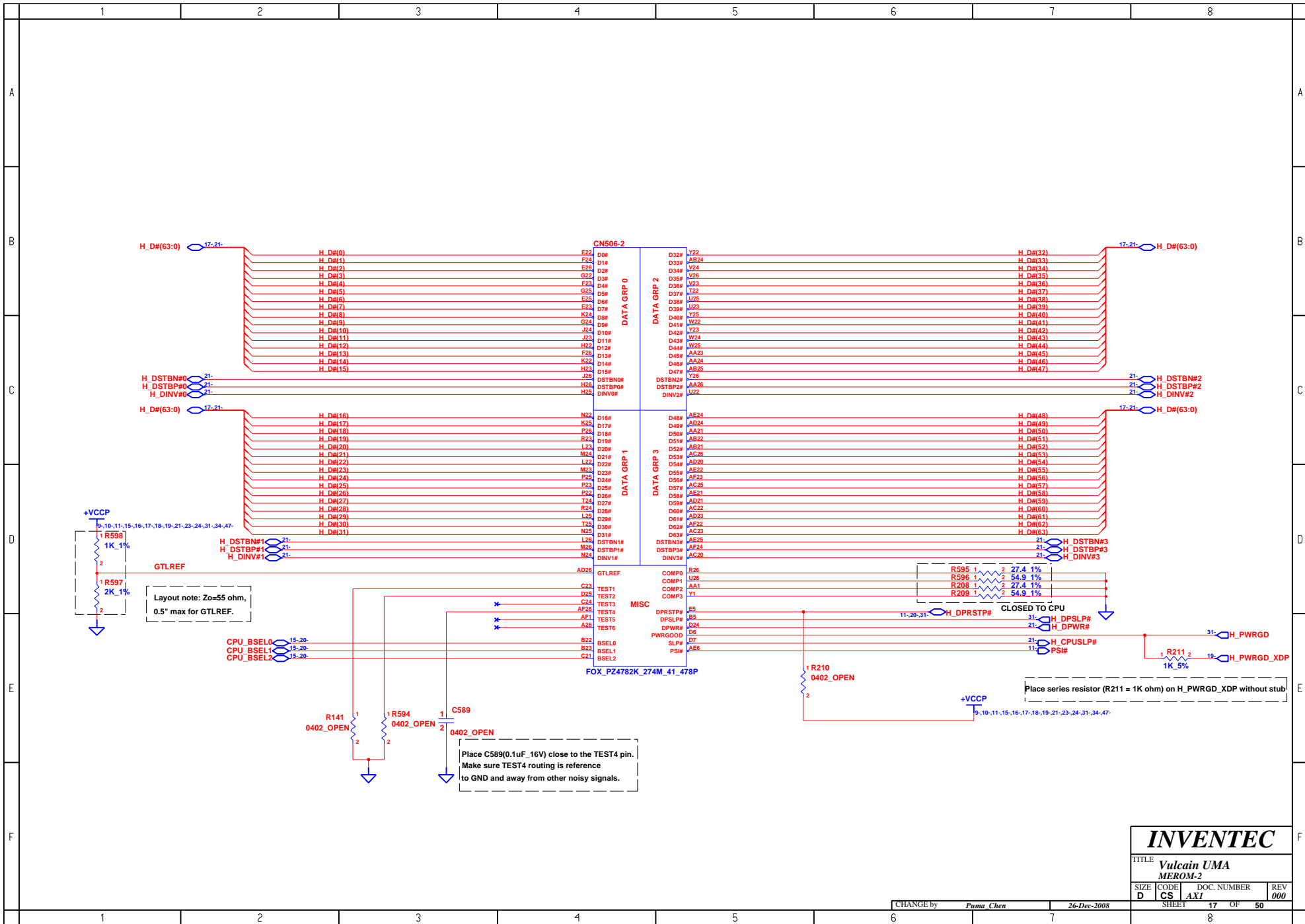

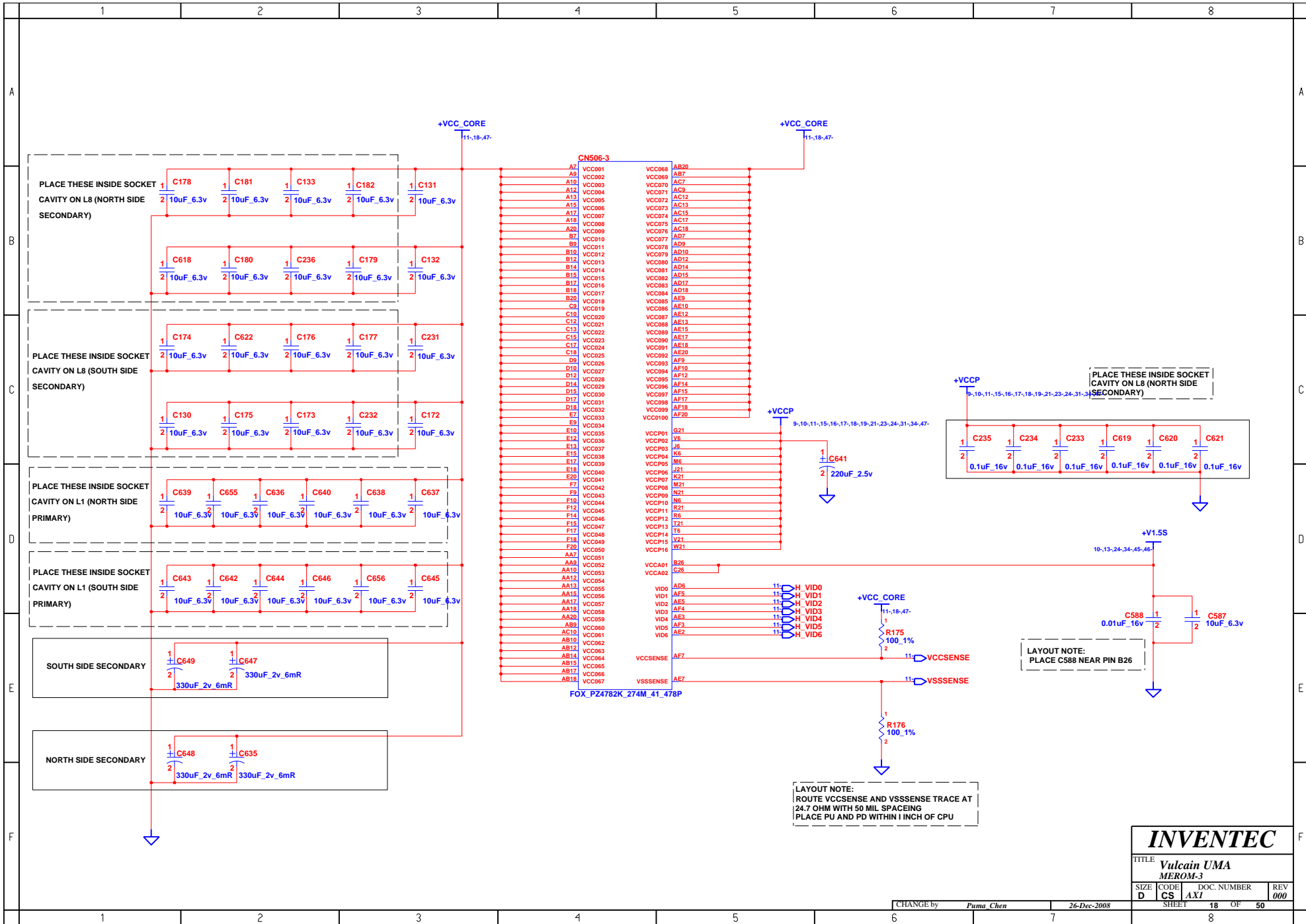

INVENTEC				
TITLE Vulcain UMA MEROM-3				
SIZE	CODE	DOC. NUMBER	REV	
D	CS	AX1	18	000
CHANGE by <i>Puma Chen</i>			26-Dec-2008	
SHEET			18	OF 50

LAYOUT NOTE:
ROUTE VCCSENSE AND VSSSENSE TRACE AT
24.7 OHM WITH 50 MIL SPACING
PLACE PU AND PD WITHIN 1 INCH OF CPU

LAYOUT NOTE:
PLACE C588 NEAR PIN B26

PLACE THESE INSIDE SOCKET
CAVITY ON L8 (NORTH SIDE
SECONDARY)

PLACE THESE INSIDE SOCKET
CAVITY ON L8 (NORTH SIDE
SECONDARY)

PLACE THESE INSIDE SOCKET
CAVITY ON L8 (SOUTH SIDE
SECONDARY)

PLACE THESE INSIDE SOCKET
CAVITY ON L1 (NORTH SIDE
PRIMARY)

PLACE THESE INSIDE SOCKET
CAVITY ON L1 (SOUTH SIDE
PRIMARY)

SOUTH SIDE SECONDARY

NORTH SIDE SECONDARY

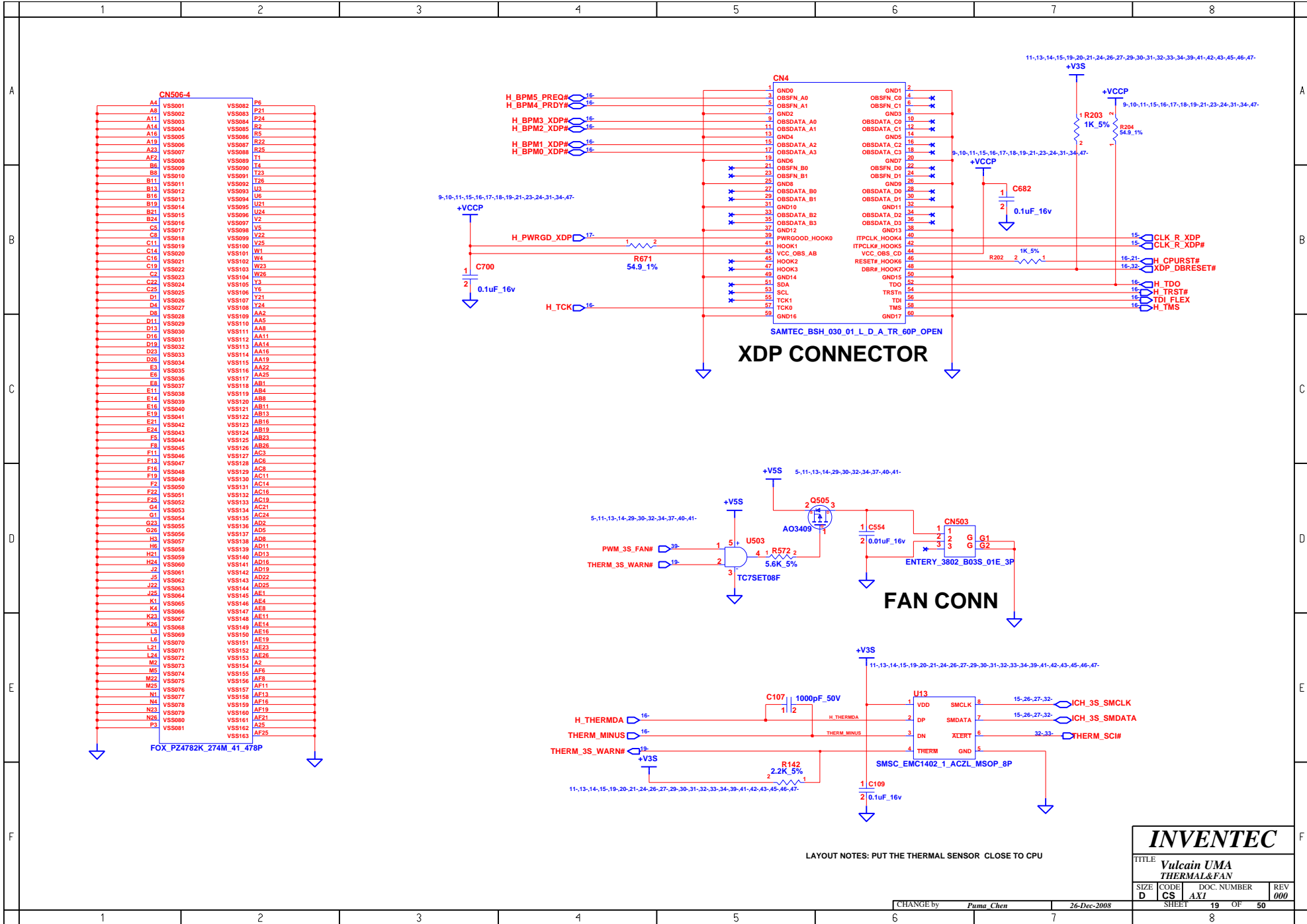

INVENTEC			
TITLE: Vulcain UMA THERMAL&FAN			
SIZE: D	CODE: CS	DOC. NUMBER: AX1	REV: 000
CHANGE by: Puma Chen		26-Dec-2008	
SHEET: 19		OF: 50	

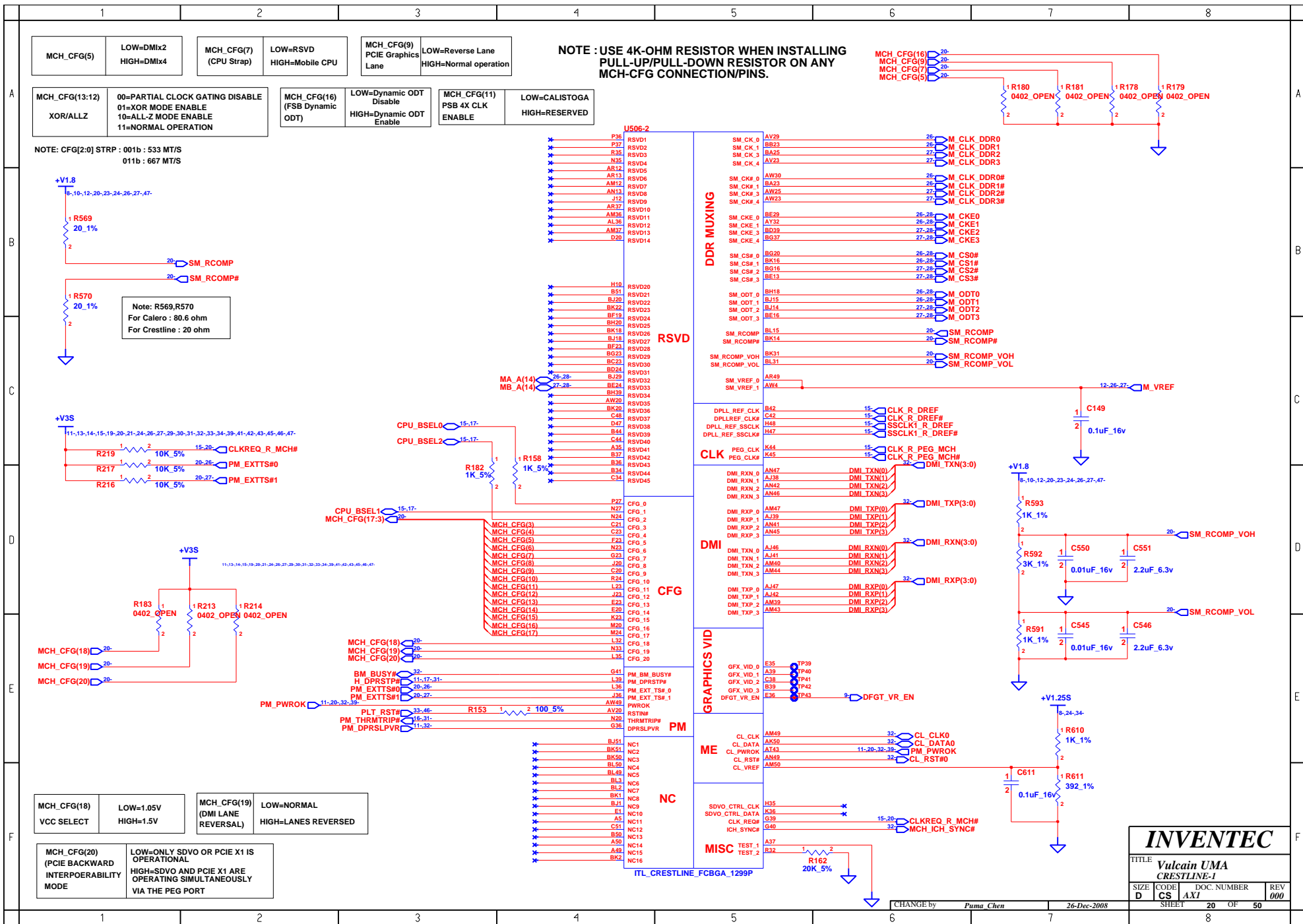

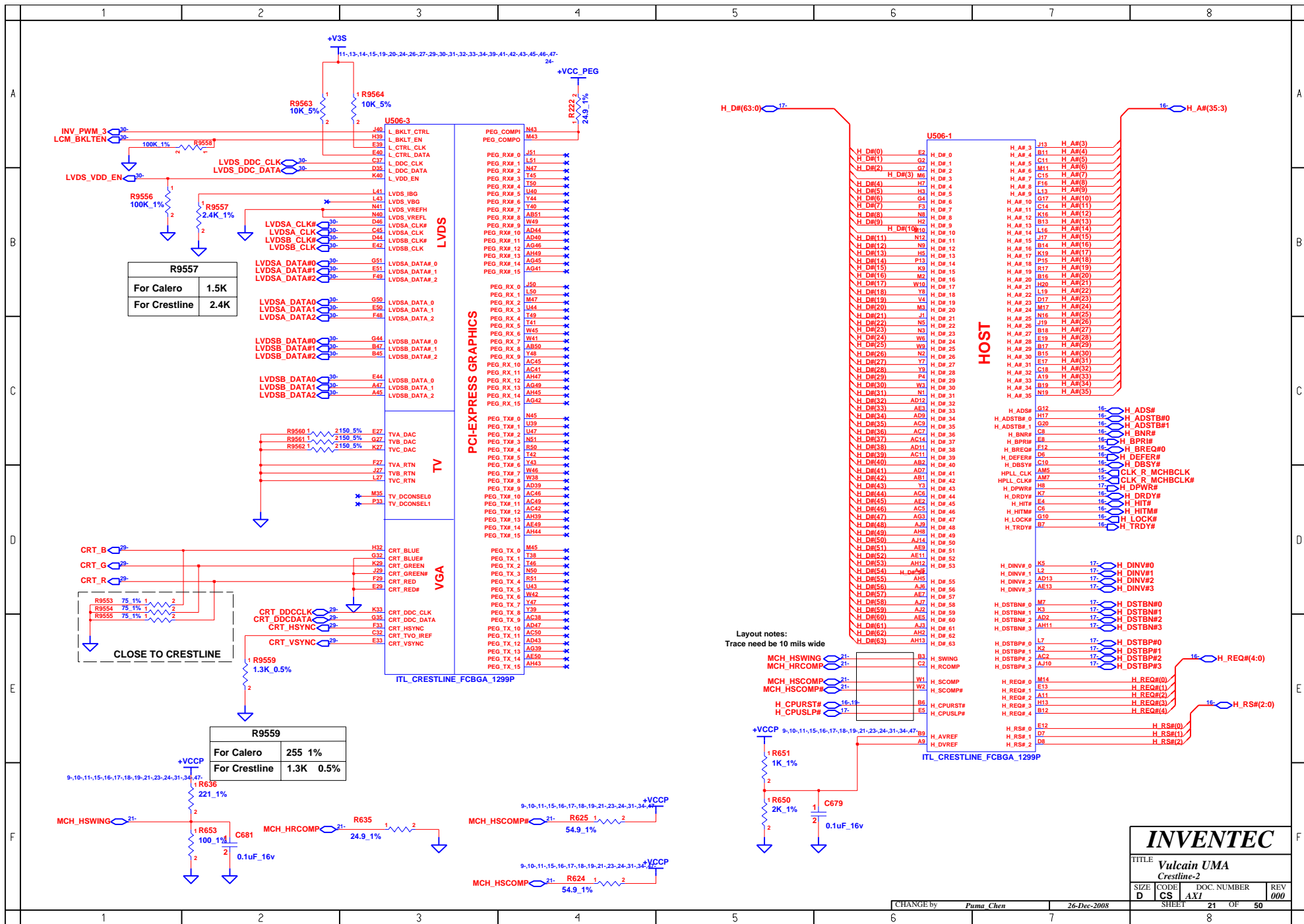

Layout notes:
Trace need be 10 mils wide

INVENTEC			
TITLE Vulcain UMA Crestline-2			
SIZE D	CODE CS	DOC. NUMBER AX1	REV 000
SHEET		21 OF	50

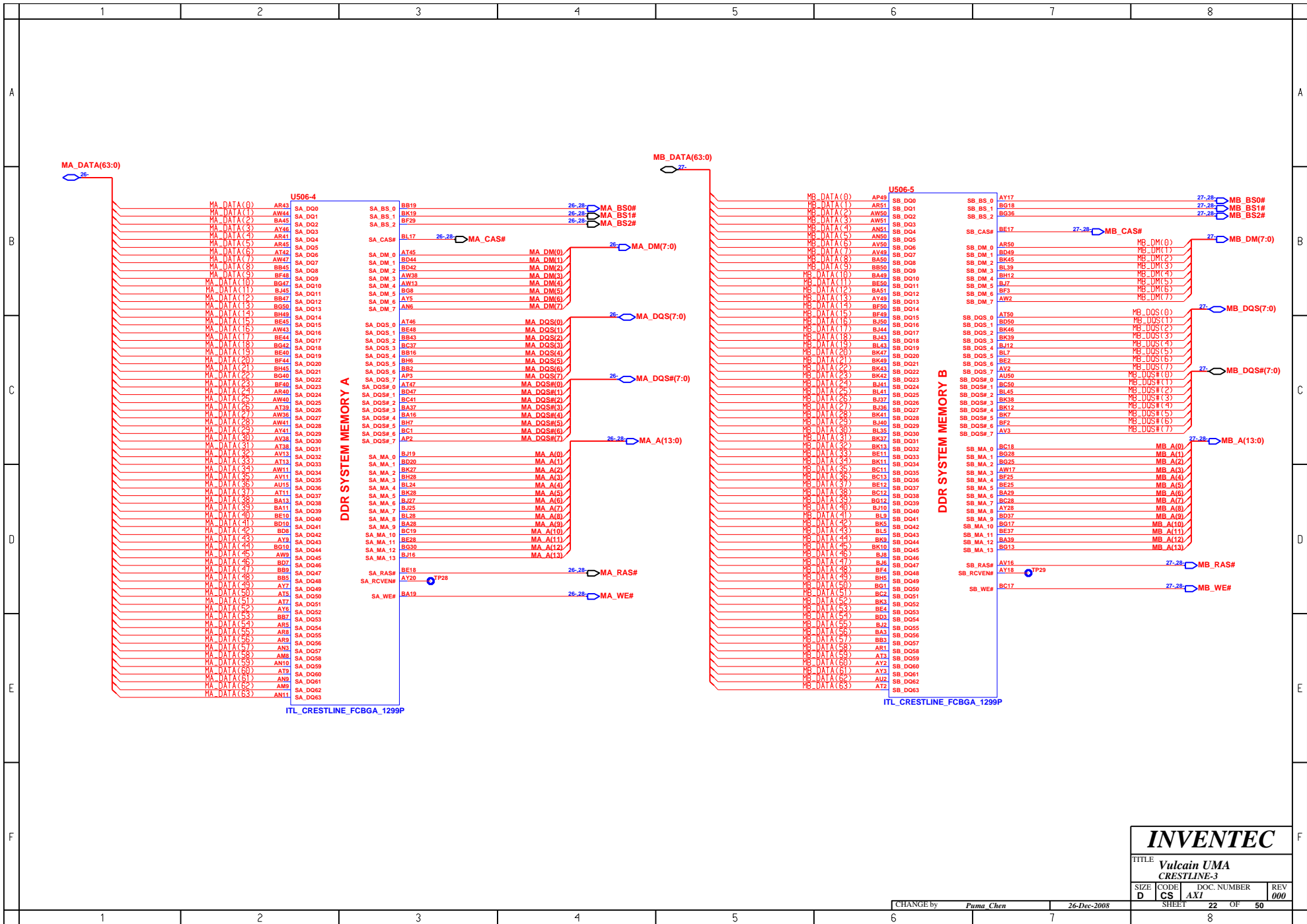

INVENTEC

TITLE
Vulcain UMA
CRESTRINE-3

SIZE	CODE	DOC. NUMBER	REV
D	CS	AX1	000

CHANGE by *Puma Chen* 26-Dec-2008
 SHEET 22 OF 50

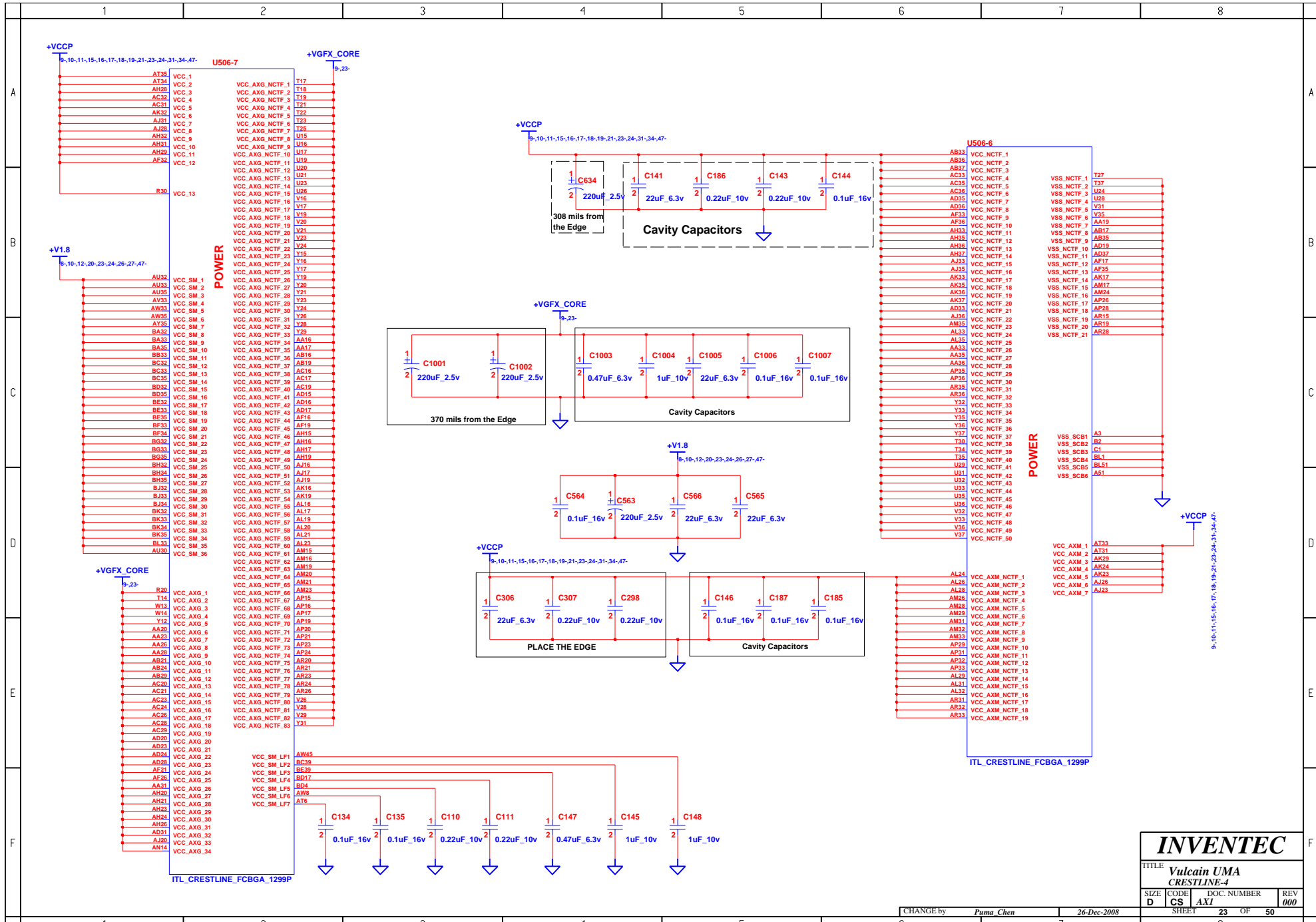

INVENTEC

TITLE
**Vulcain UMA
 CRESTLINE-4**

SIZE	CODE	CS	DOC. NUMBER	REV
D	CS	AXI	23 OF 50	000

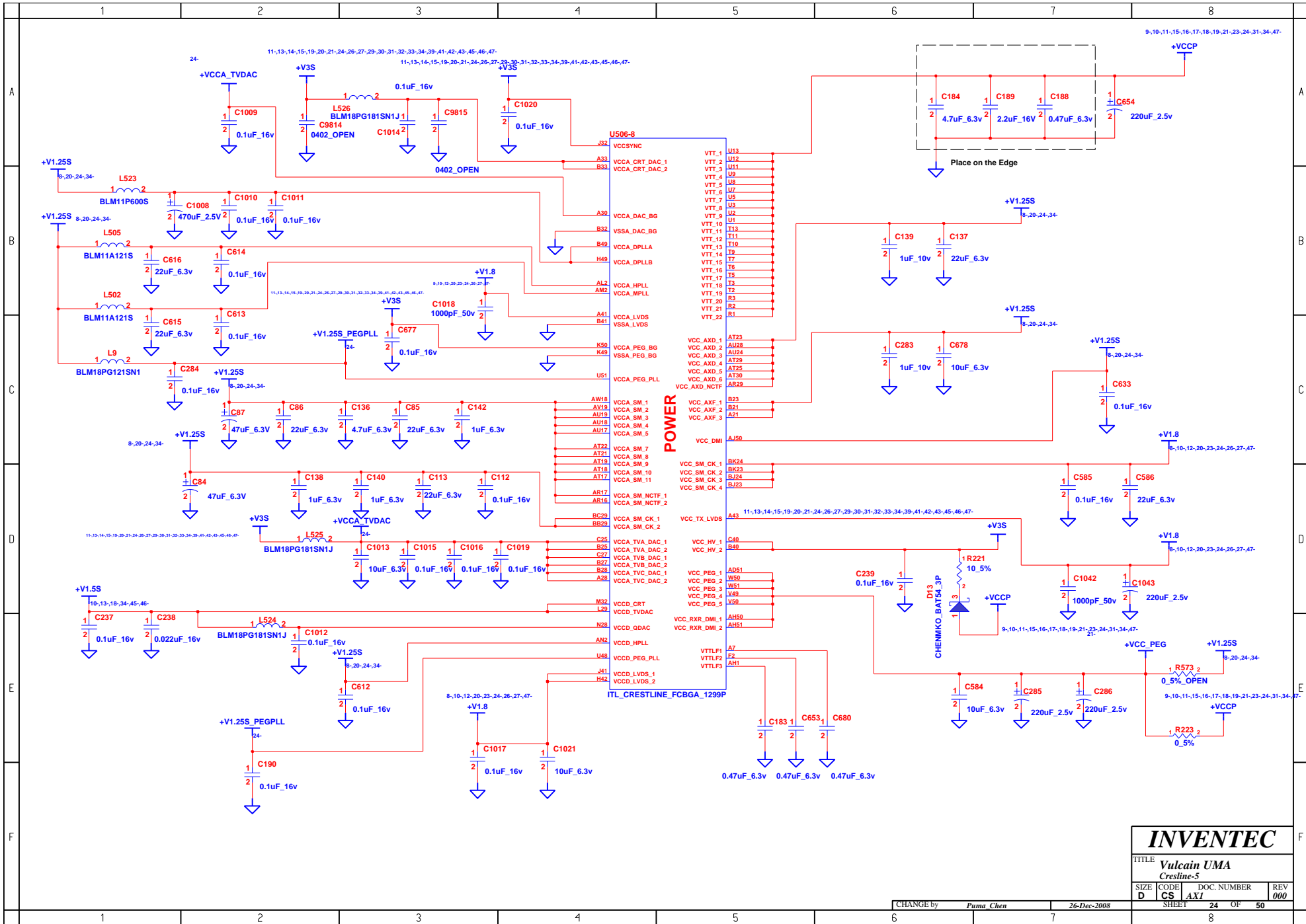

INVENTEC			
TITLE Vulcain UMA Crestline-5			
SIZE D	CODE CS	DOC. NUMBER AX1	REV 000
CHANGE by <i>Puma Chen</i>		26-Dec-2008	
SHEET 24		OF 50	

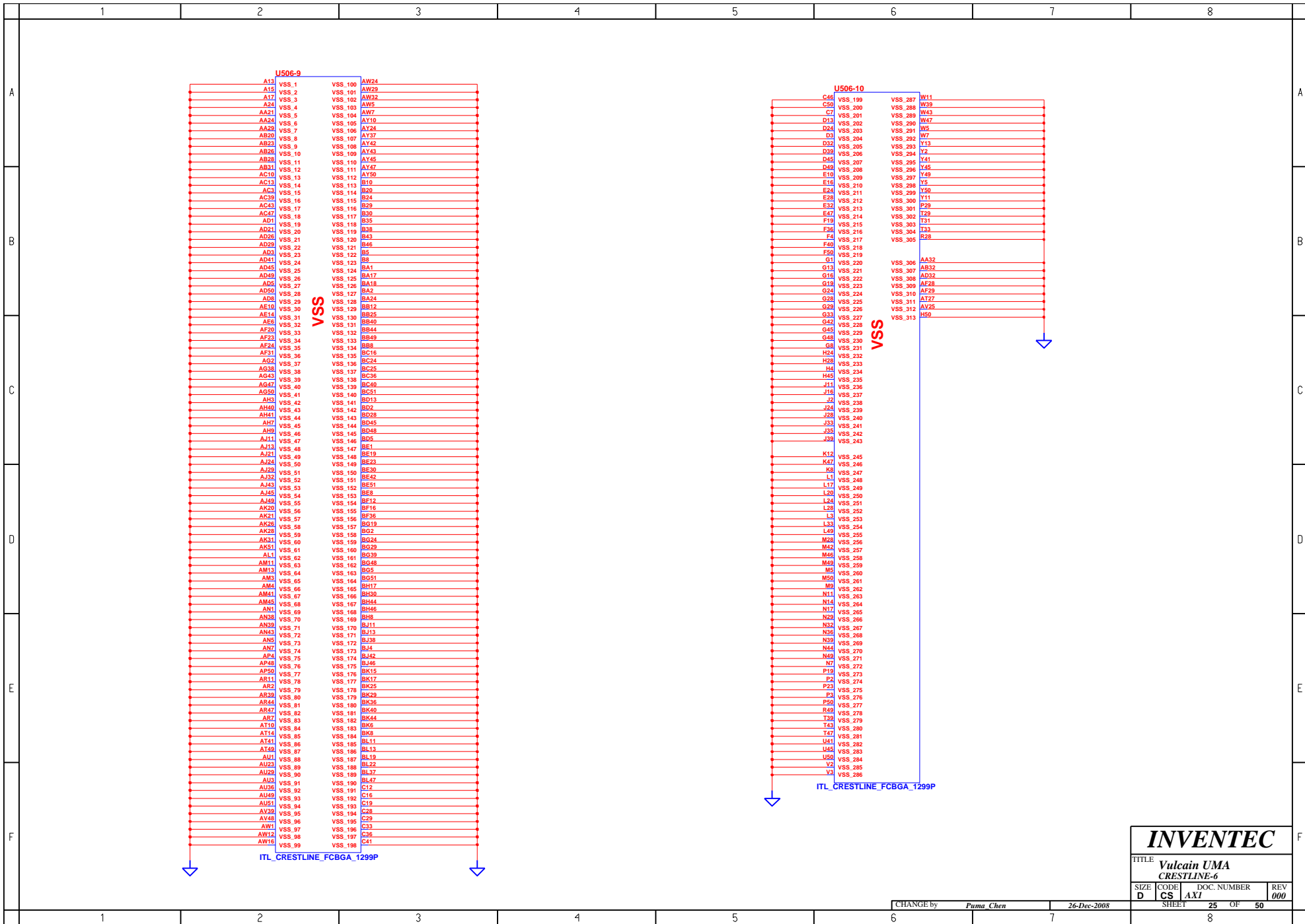

INVENTEC

TITLE
**Vulcain UMA
 CRESTLINE-6**

SIZE	CODE	DOC. NUMBER	REV
D	CS	AXI	000

CHANGE by *Puma Chen* 26-Dec-2008

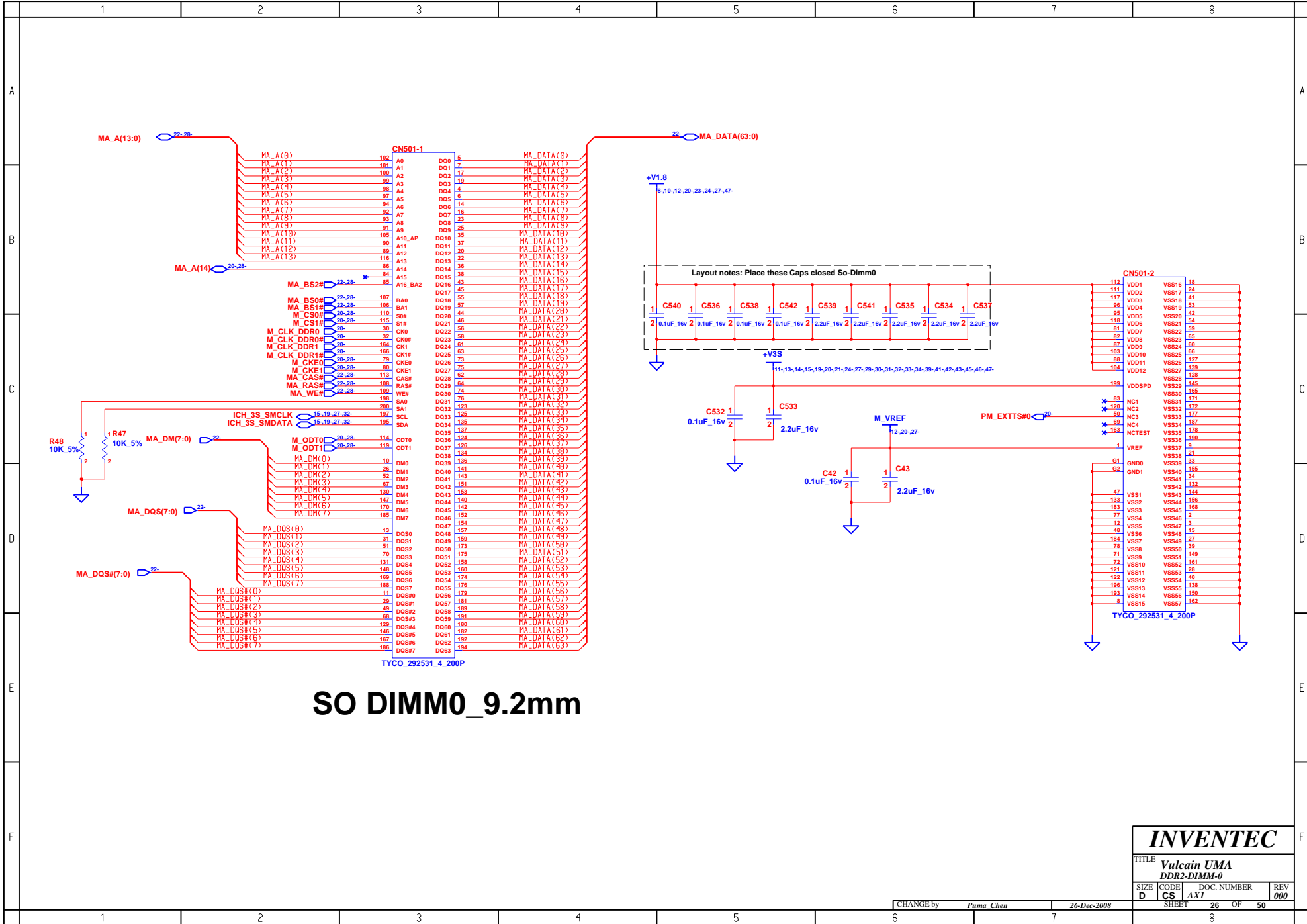

INVENTEC				
TITLE Vulcain UMA DDR2-DIMM-0				
SIZE D	CODE CS	DOC. NUMBER AX1	REV 000	
CHANGE by <i>Puma Chen</i>			26-Dec-2008	
SHEET			26 OF	50

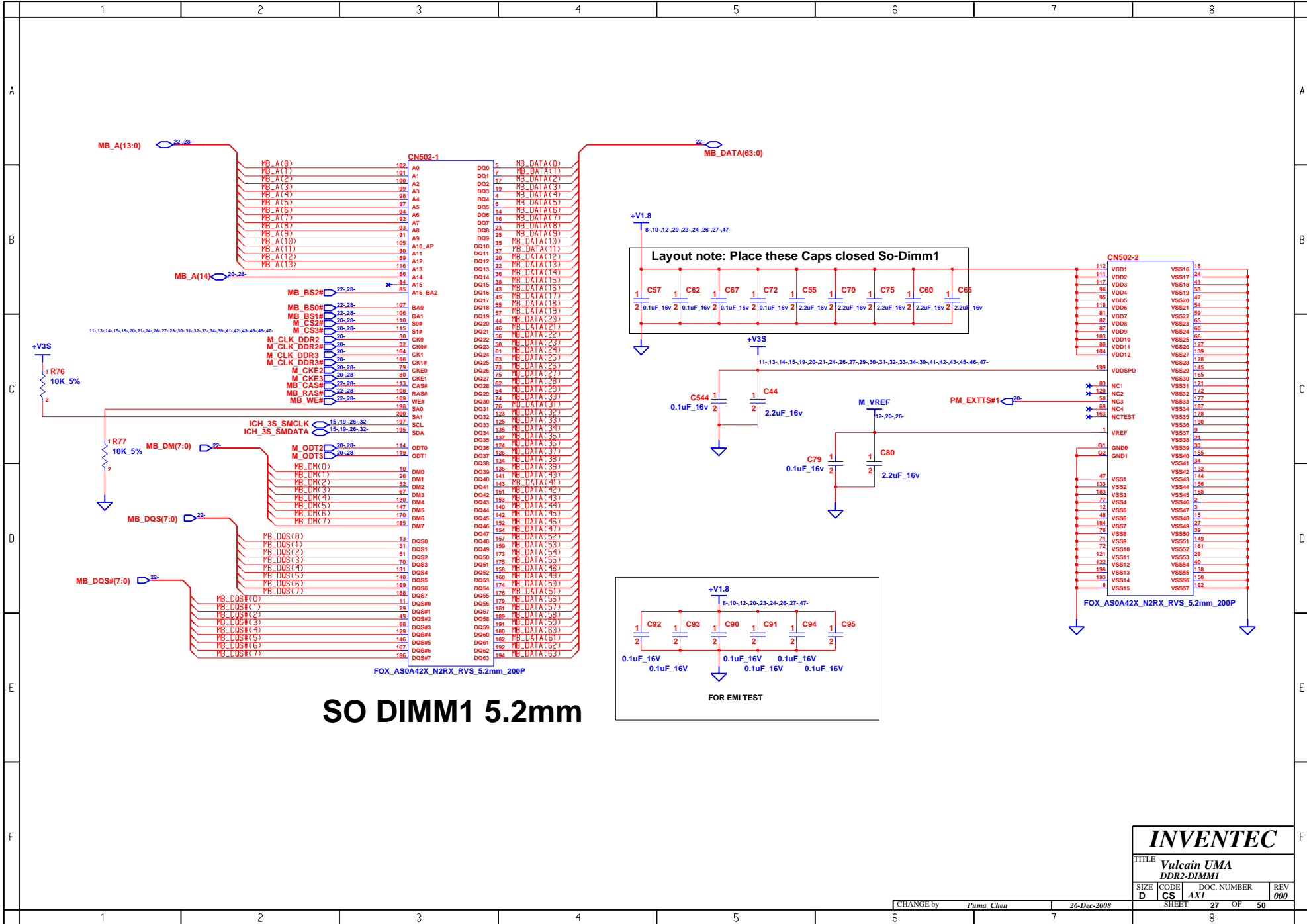

SO DIMM 5.2mm

INVENTEC

TITLE
**Vulcain UMA
 DDR2-DIMM1**

SIZE	CODE	DOC. NUMBER	REV
D	CS	AX1	000

CHANGE by	DATE	SHEET	OF	TOTAL
Puma Chen	26-Dec-2008	27	OF	50

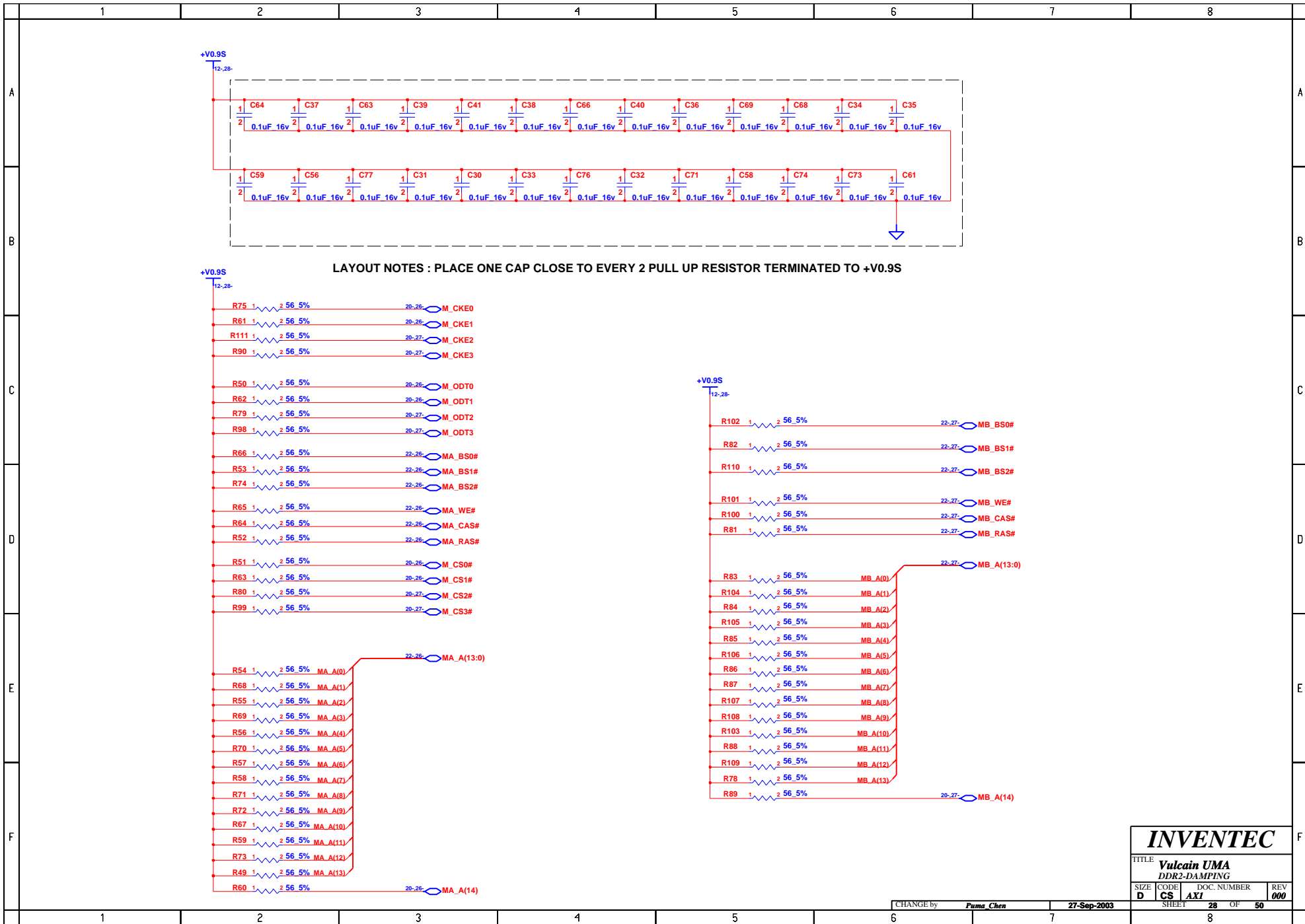

INVENTEC			
TITLE Vulcain UMA			
DDR2-DAMPING			
SIZE	CODE	DOC. NUMBER	REV
D	CS	AXI	000
CHANGE by Puma Chen		27-Sep-2003	
SHEET		28	OF 50
		8	

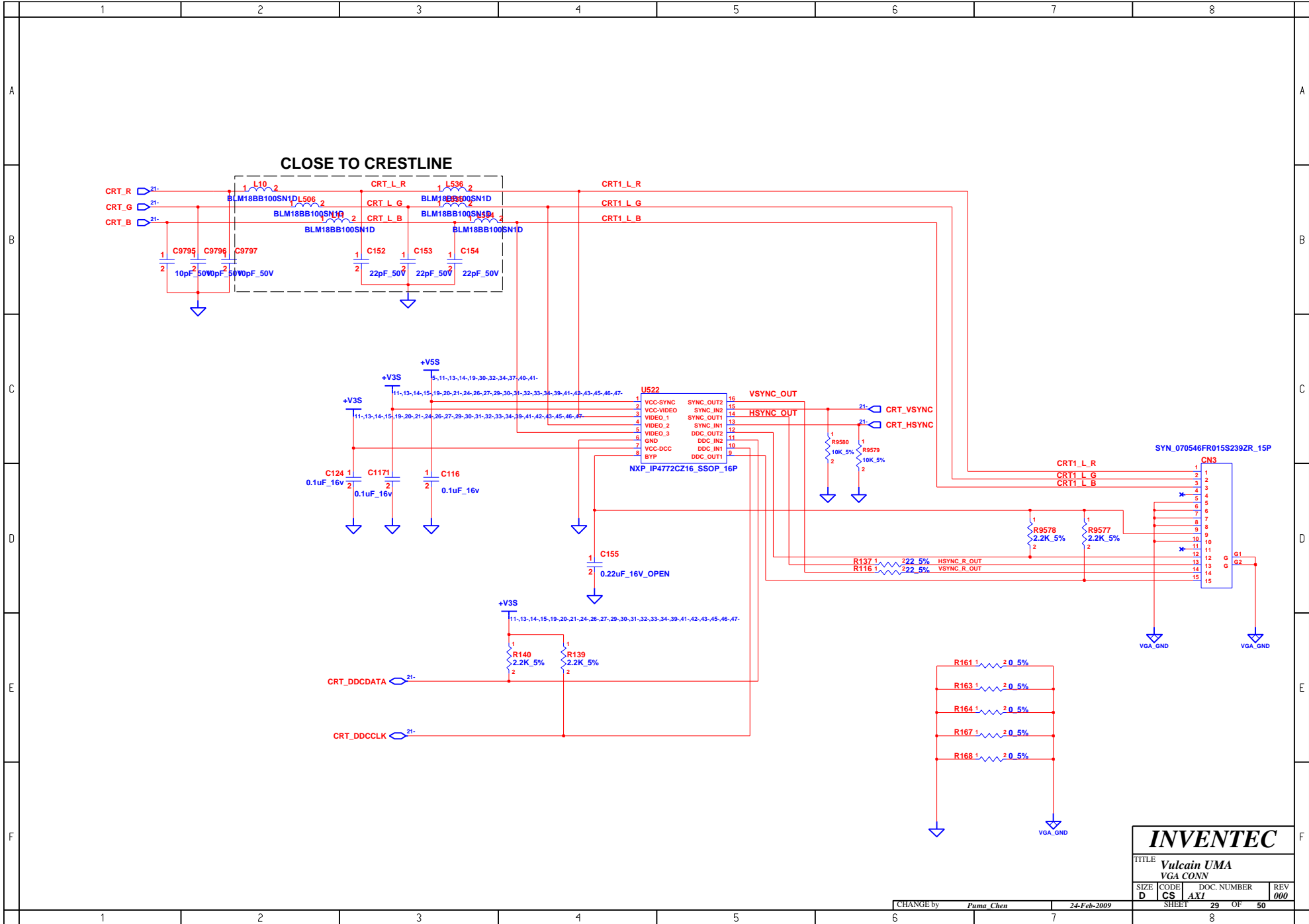

INVENTEC			
TITLE Vulcain UMA VGA CONN			
SIZE D	CODE CS	DOC. NUMBER AXI	REV 000
CHANGE by Puma Chen		24-Feb-2009	
SHEET		29 OF 50	
1		8	

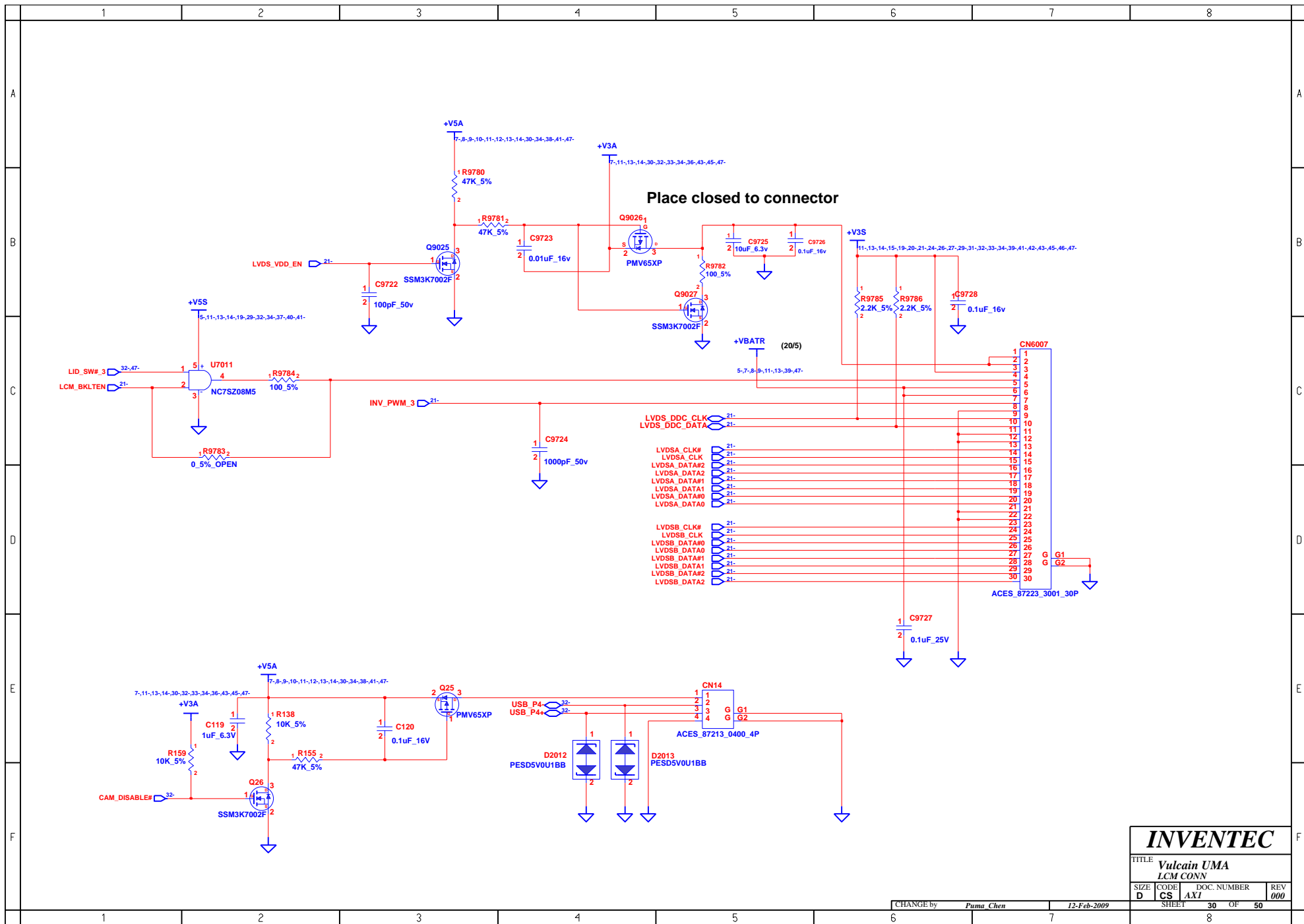

INVENTEC			
TITLE Vulcain UMA LCM CONN			
SIZE D	CODE CS	DOC. NUMBER AX1	REV 000
CHANGE by <i>Puma Chen</i>		12-Feb-2009	
SHEET		30 OF	50
		8	

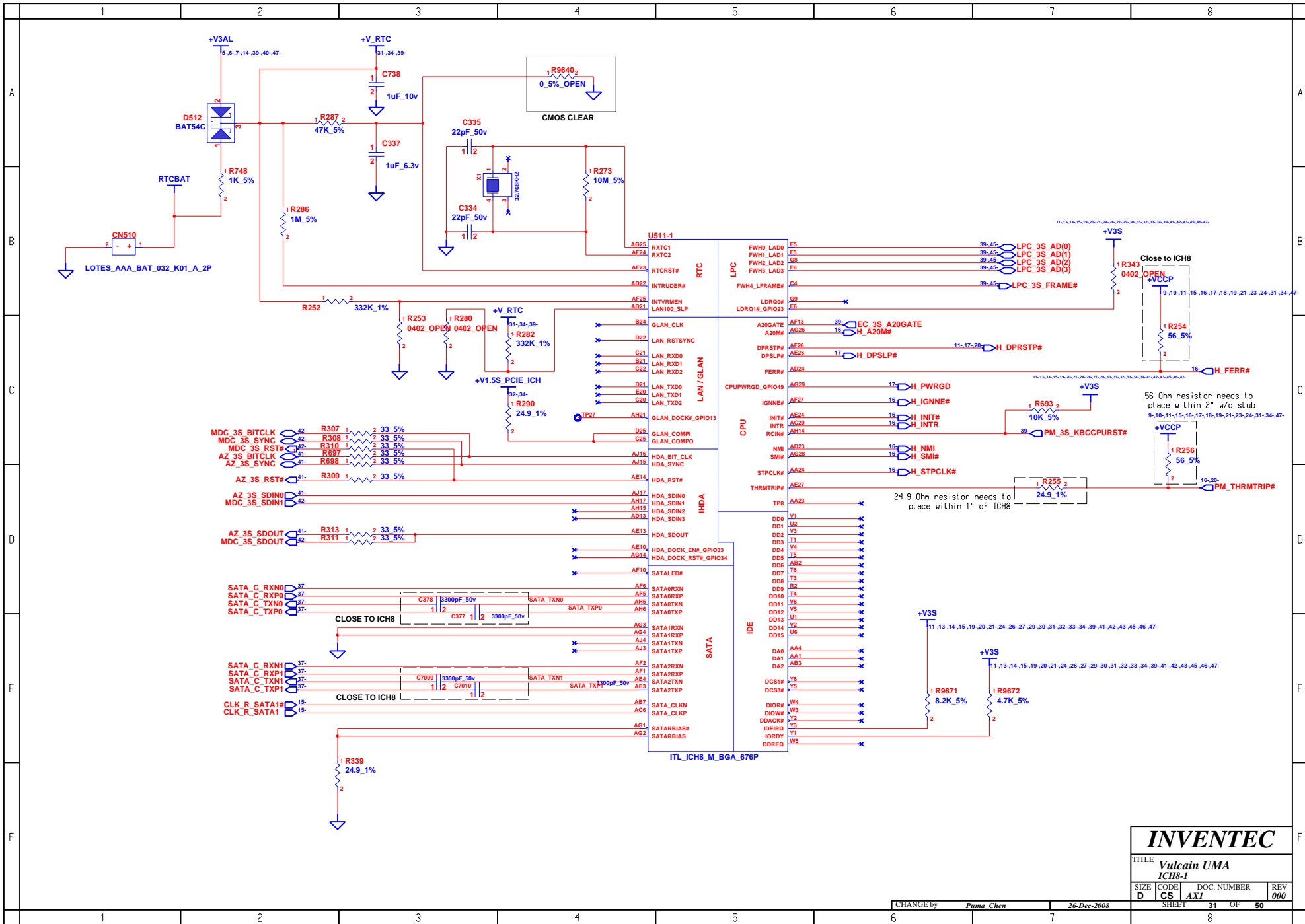

INVENTEC			
TITLE Vulcain UMA ICH8-1			
SIZE D	CODE CS	DOC. NUMBER AXI	REV 000
CHANGE by <i>Puma Chen</i>		26-Dec-2008	
SHEET		31 OF 50	

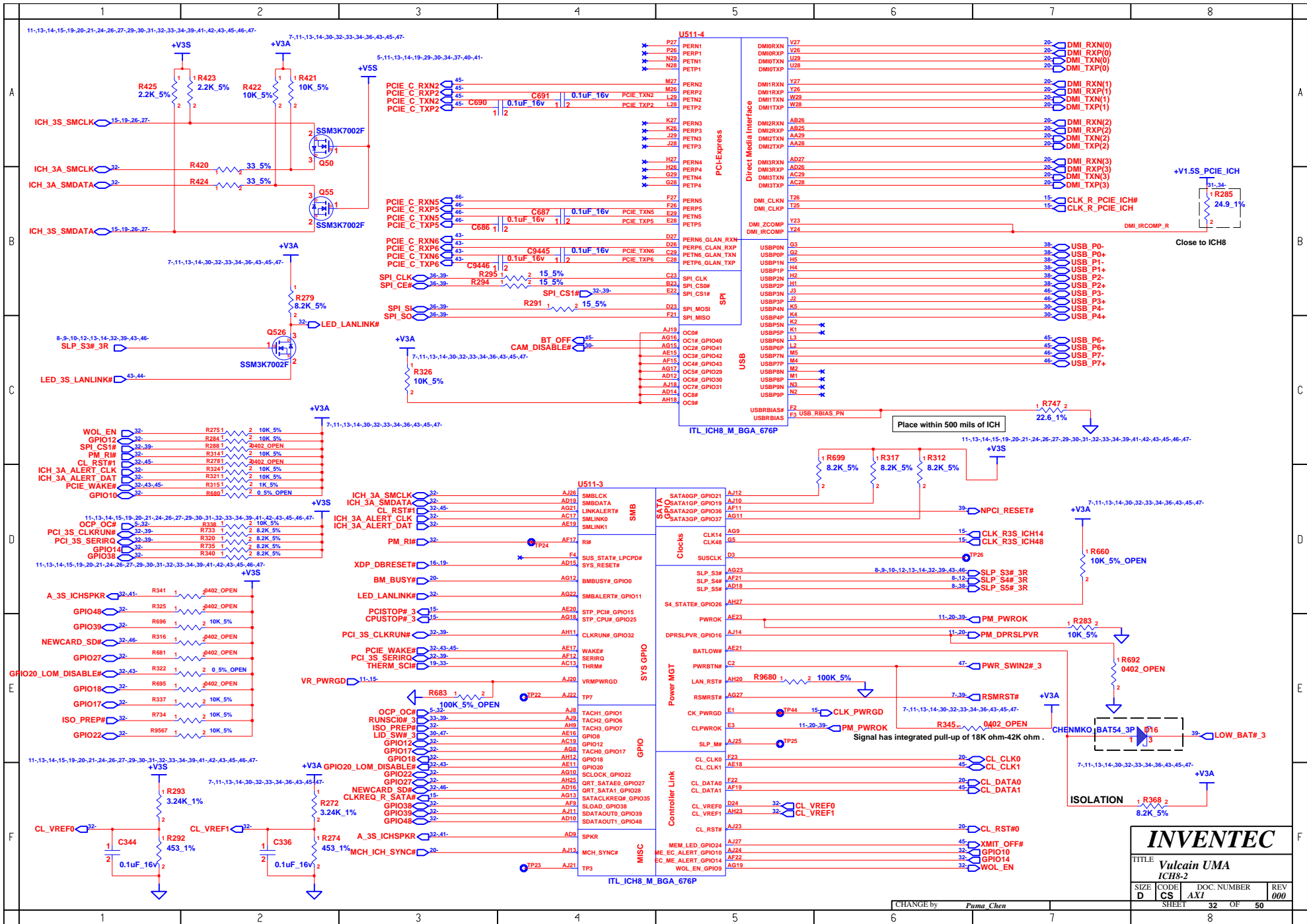

INVENTEC			
TITLE Vulcain UMA ICH8-2			
SIZE D	CODE CS	DOC. NUMBER AX1	REV 000
SHEET		32 OF	50

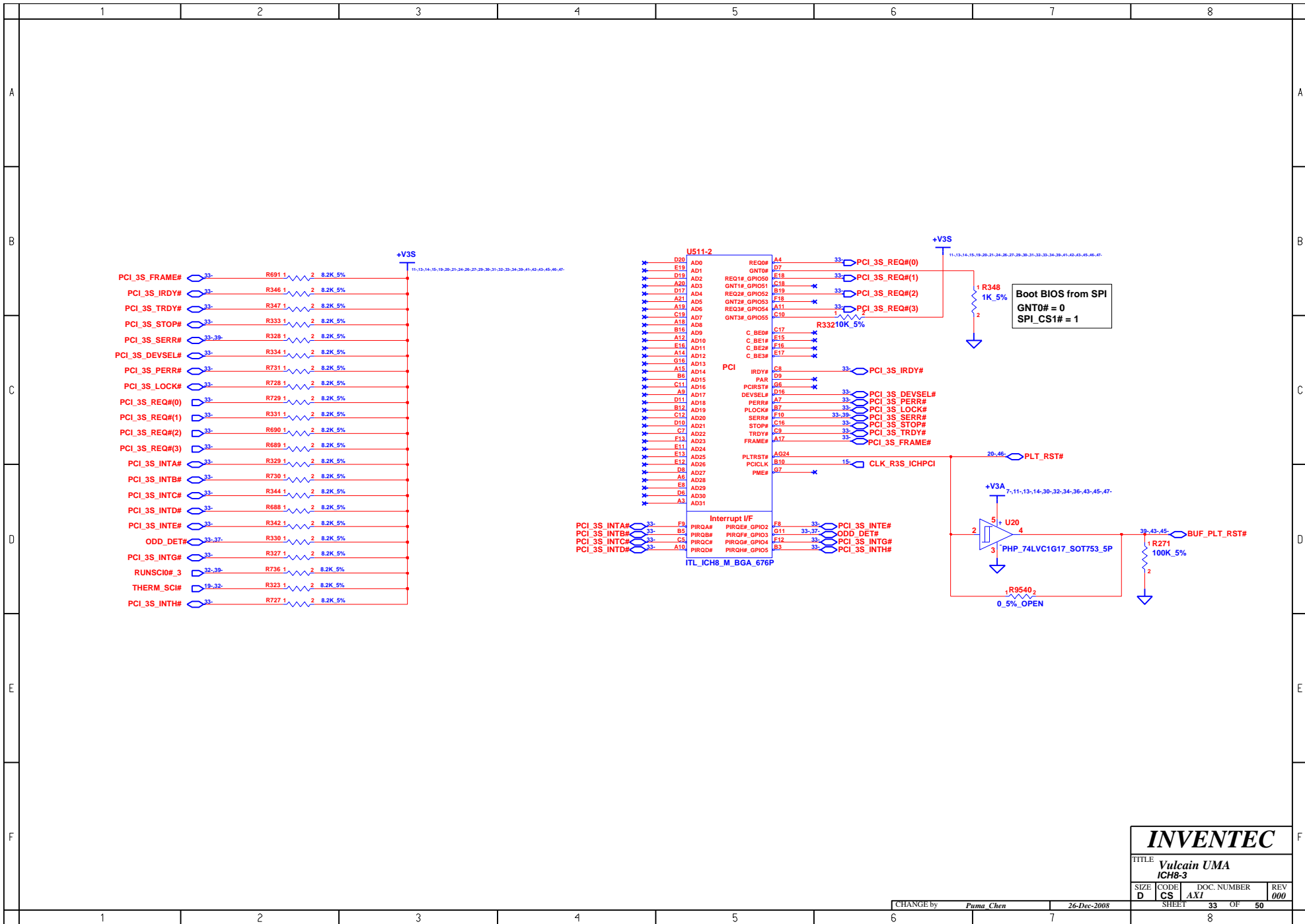

INVENTEC			
TITLE Vulcain UMA ICH8-3			
SIZE D	CODE CS	DOC. NUMBER AX1	REV 000
CHANGE by Puma Chen		26-Dec-2008	
SHEET		33 OF	50

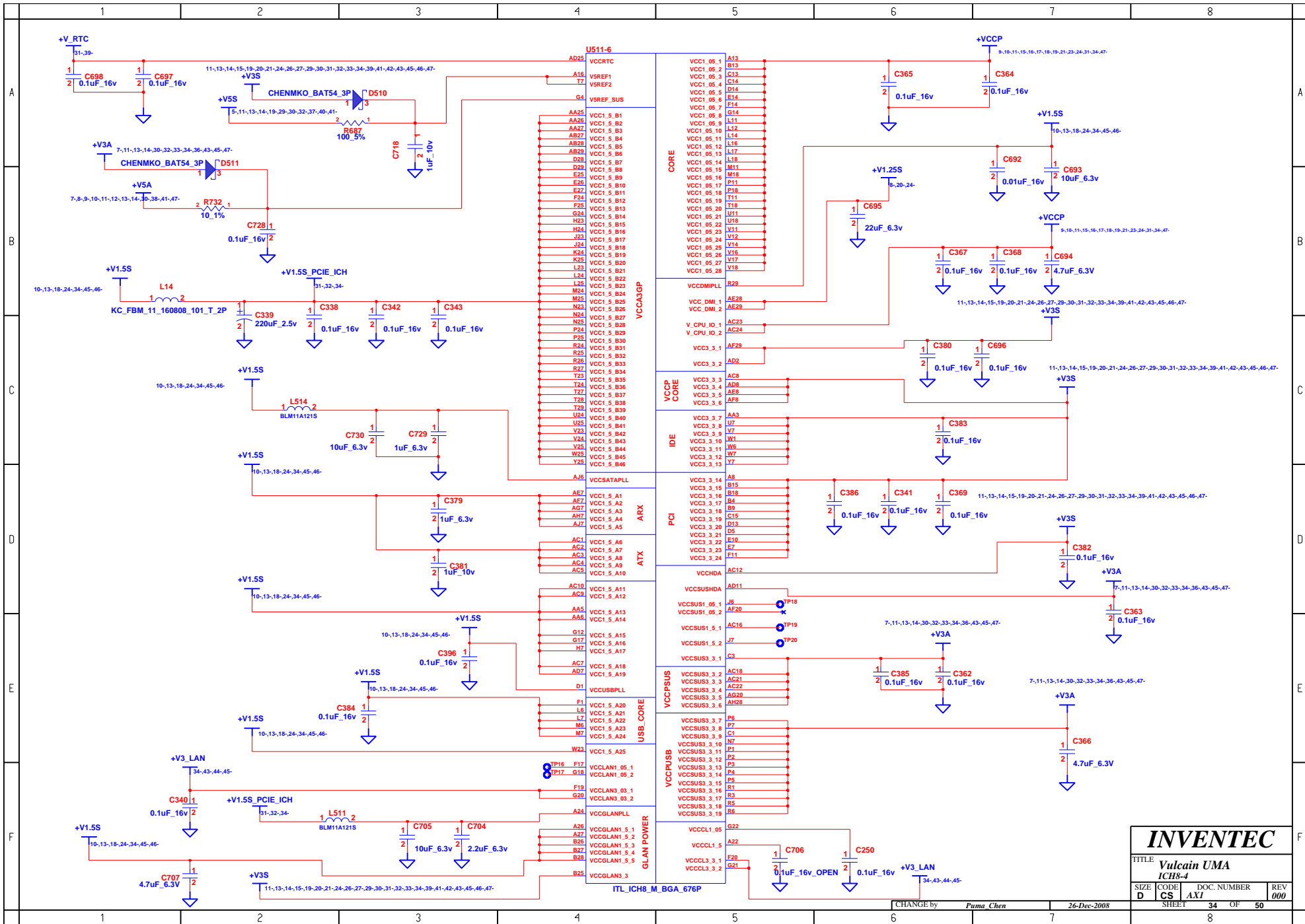

INVENTEC			
TITLE Vulcain UMA			
ICHS-4			
SIZE	CODE	DOC. NUMBER	REV
D	CS	AXI	000
SHEET		34 OF	50

CHANGE by *Puma Chen* 26-Dec-2008

	1	2	3	4	5	6	7	8	
A									A
B									B
C									C
D									D
E									E
F									F

US11-5

A23	VSS001	VSS099	K7
AA	VSS002	VSS100	L1
AA2	VSS003	VSS101	L13
AA7	VSS004	VSS102	L15
AA8	VSS005	VSS103	L26
AB1	VSS006	VSS104	L27
AB24	VSS007	VSS105	L4
AC11	VSS008	VSS106	L9
AC14	VSS009	VSS107	M2
AC25	VSS010	VSS108	M13
AC28	VSS011	VSS109	M14
AC27	VSS012	VSS110	M15
AD17	VSS013	VSS111	M16
AD20	VSS014	VSS112	M17
AD28	VSS015	VSS113	M23
AD29	VSS016	VSS114	M28
AD3	VSS017	VSS115	M29
AD4	VSS018	VSS116	M3
AD6	VSS019	VSS117	N1
AE1	VSS020	VSS118	N11
AE12	VSS021	VSS119	N12
AE2	VSS022	VSS120	N13
AE22	VSS023	VSS121	N14
AD1	VSS024	VSS122	N15
AE26	VSS025	VSS123	N16
AE5	VSS026	VSS124	N17
AE6	VSS027	VSS125	N18
AE9	VSS028	VSS126	N29
AF14	VSS029	VSS127	N27
AF16	VSS030	VSS128	N4
AF18	VSS031	VSS129	N5
AF3	VSS032	VSS130	N6
AF4	VSS033	VSS131	P12
AG5	VSS034	VSS132	P13
AG6	VSS035	VSS133	P14
AH10	VSS036	VSS135	P15
AH13	VSS037	VSS136	P16
AH16	VSS038	VSS136	P17
AH19	VSS039	VSS137	P23
AM2	VSS040	VSS138	P28
AF28	VSS041	VSS139	P29
AH22	VSS042	VSS140	R11
AH24	VSS043	VSS141	R12
AH26	VSS044	VSS142	R13
AH3	VSS045	VSS143	R14
AH4	VSS046	VSS144	R15
AH8	VSS047	VSS145	R16
AJ5	VSS048	VSS146	R17
B11	VSS049	VSS147	R18
B14	VSS050	VSS148	R28
B17	VSS051	VSS149	R4
B2	VSS052	VSS150	T12
B20	VSS053	VSS151	T13
B22	VSS054	VSS152	T14
B6	VSS055	VSS153	T15
C24	VSS056	VSS154	T16
C28	VSS057	VSS155	T17
C27	VSS058	VSS156	T2
C6	VSS059	VSS157	U12
D12	VSS060	VSS158	U13
D15	VSS061	VSS159	U14
D18	VSS062	VSS160	U15
D2	VSS063	VSS161	U16
D4	VSS064	VSS162	U17
E21	VSS065	VSS163	U23
E24	VSS066	VSS164	U26
E4	VSS067	VSS165	U27
E9	VSS068	VSS166	U3
F15	VSS069	VSS167	U5
E24	VSS070	VSS168	V13
F28	VSS071	VSS169	V15
F28	VSS072	VSS170	V28
F7	VSS073	VSS171	V29
G1	VSS074	VSS172	W2
E2	VSS075	VSS173	W26
G10	VSS076	VSS174	W27
G13	VSS077	VSS175	Y28
G19	VSS078	VSS176	Y29
G23	VSS079	VSS177	Y4
G25	VSS080	VSS178	AB4
G26	VSS081	VSS179	AB23
G27	VSS082	VSS180	AB5
H25	VSS083	VSS181	AB6
H28	VSS084	VSS182	AD5
H29	VSS085	VSS183	U4
H3	VSS086	VSS184	W24
H6	VSS087	VSS_NCTF_01	A1
J1	VSS088	VSS_NCTF_02	A2
J26	VSS089	VSS_NCTF_03	A28
J26	VSS090	VSS_NCTF_04	A29
J27	VSS091	VSS_NCTF_05	AH1
J4	VSS092	VSS_NCTF_06	AH29
J5	VSS093	VSS_NCTF_07	AJ1
K23	VSS094	VSS_NCTF_08	AJ2
K28	VSS095	VSS_NCTF_09	AJ28
K29	VSS096	VSS_NCTF_10	AJ29
K3	VSS097	VSS_NCTF_11	B1
K6	VSS098	VSS_NCTF_12	B29

ITL_ICH8_M_BGA_676P

INVENTEC

TITLE **Vulcain UMA**
ICH8-5

SIZE	CODE	DOC. NUMBER	REV
D	CS	AX1	000

SHEET 35 OF 50

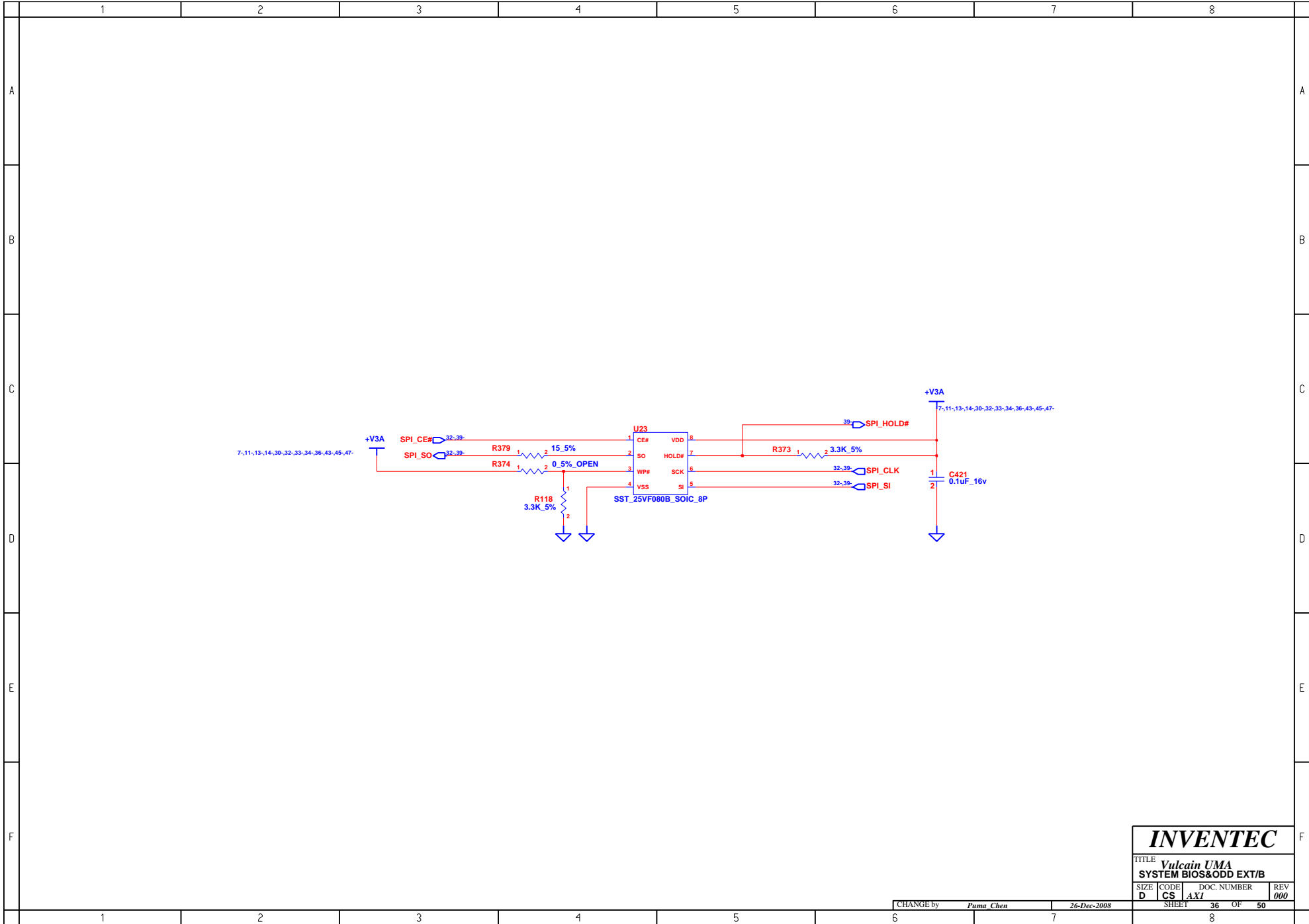

INVENTEC

TITLE **Vulcain UMA**
SYSTEM BIOS&ODD EXT/B

SIZE	CODE	DOC. NUMBER	REV
D	CS	AX1	000

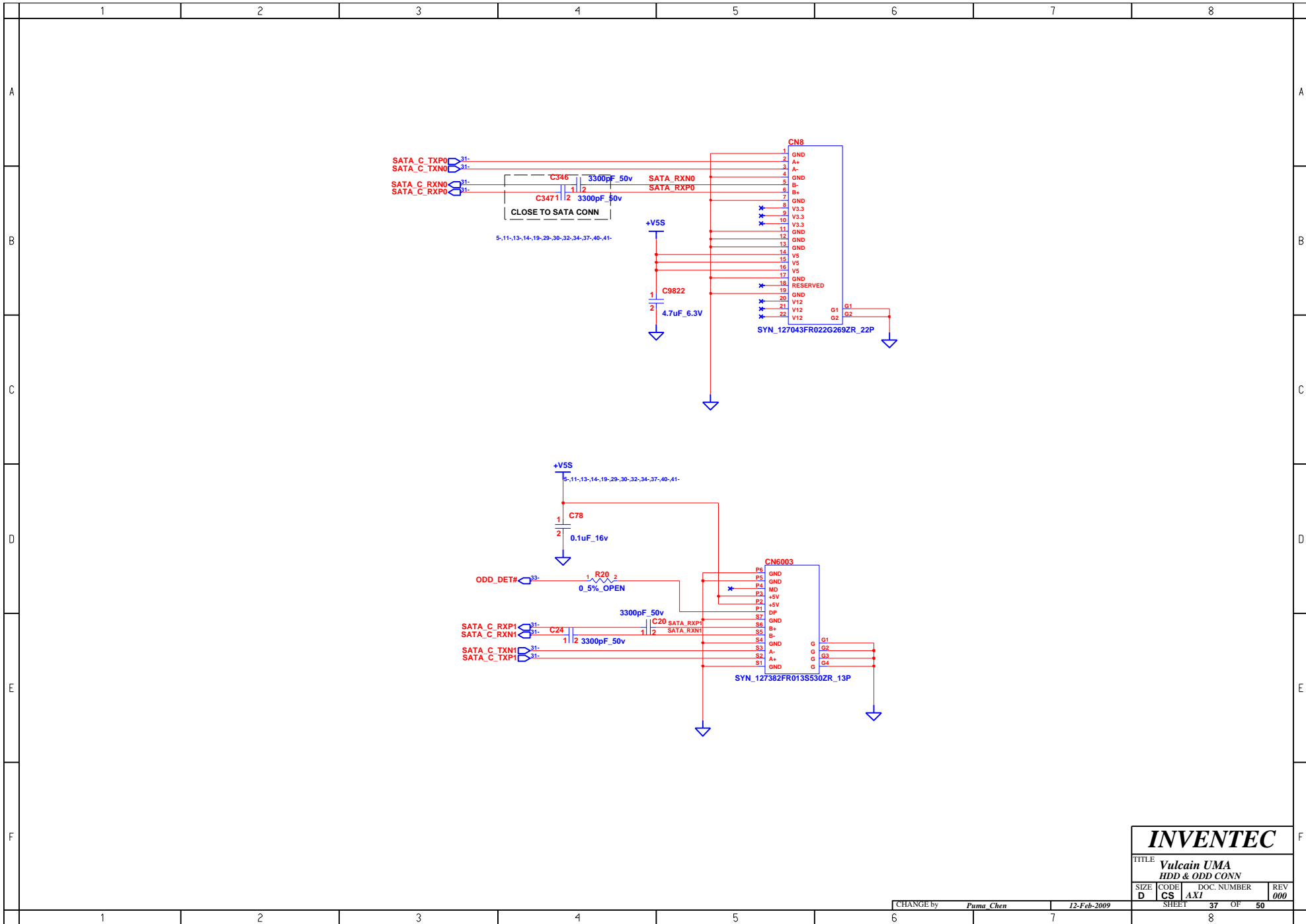

INVENTEC

TITLE
**Vulcain UMA
 HDD & ODD CONN**

SIZE D	CODE CS	DOC. NUMBER AX1	REV 000
------------------	-------------------	---------------------------	-------------------

CHANGE by *Puma Chen* 12-Feb-2009

SHEET	37	OF	50
-------	----	----	----

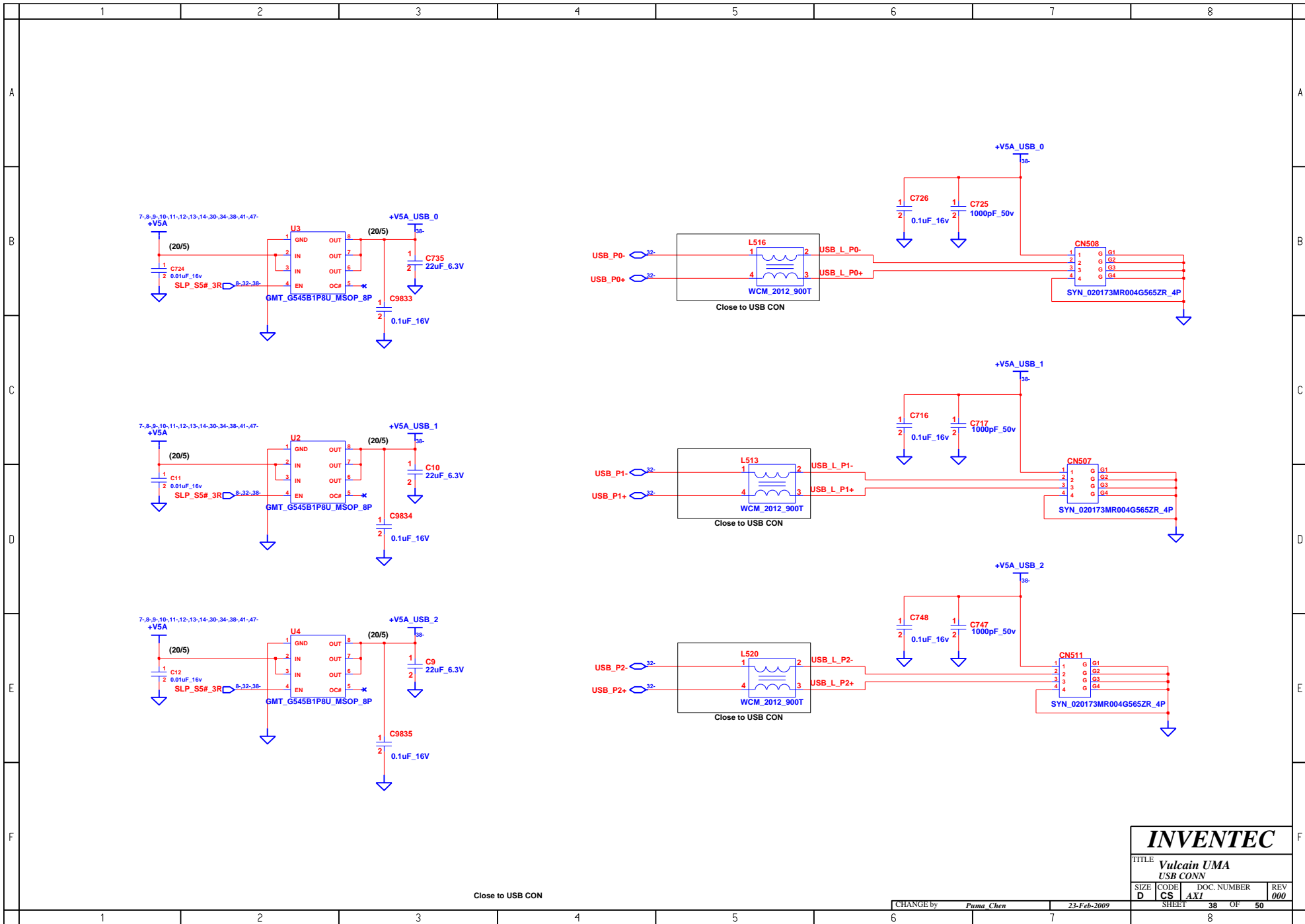

Close to USB CON

INVENTEC			
TITLE Vulcain UMA USB CONN			
SIZE D	CODE CS	DOC. NUMBER AXI	REV 000
CHANGE by <i>Puma Chen</i>		23-Feb-2009	
SHEET		38	OF 50

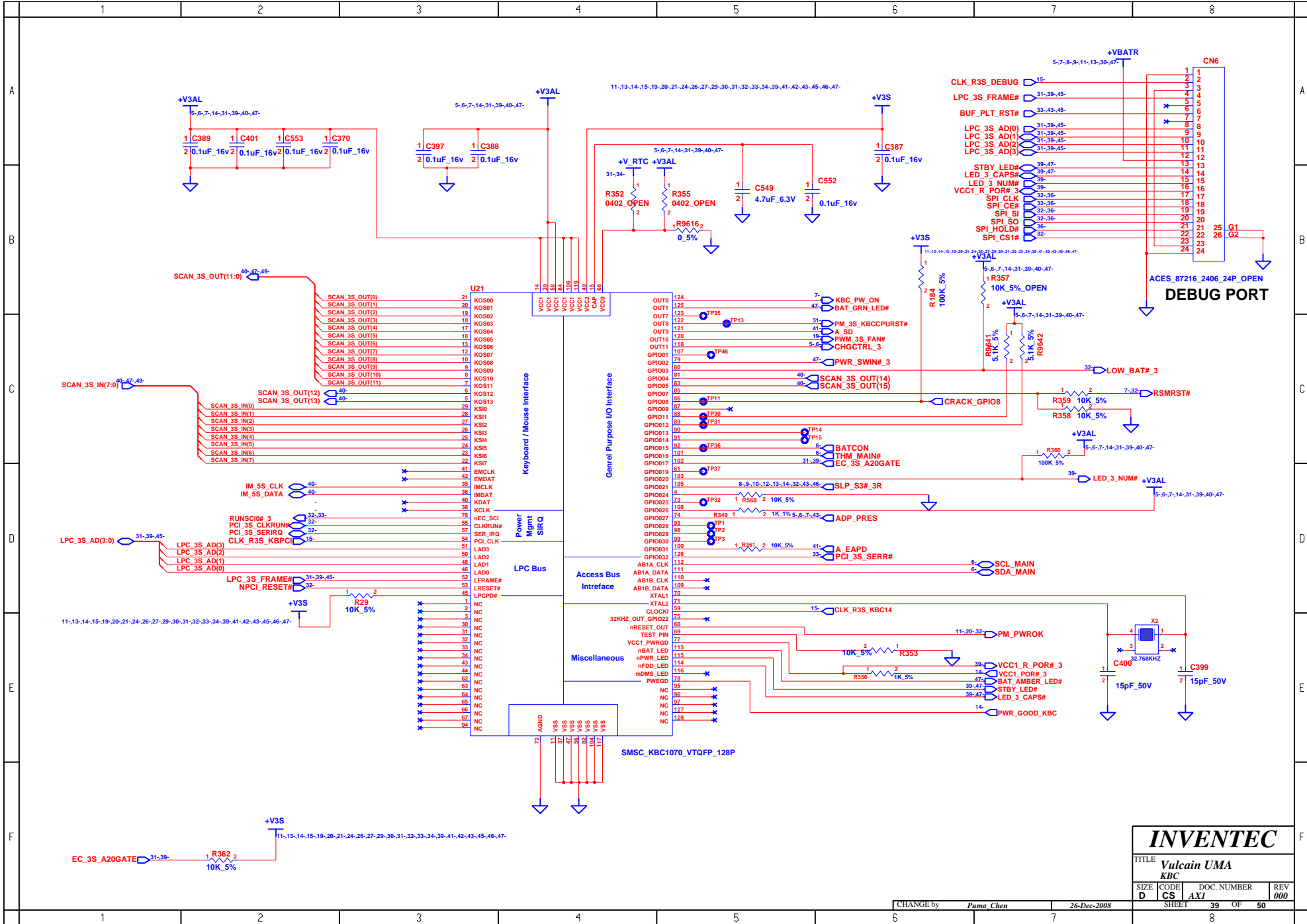

INVENTEC			
TITLE Vulcain UMA			
KBC			
SIZE	CODE	DOC. NUMBER	REV
D	CS	AXI	000
CHANGE by		26-Dec-2008	
Puma Chen		39 OF 50	
SHEET		8	

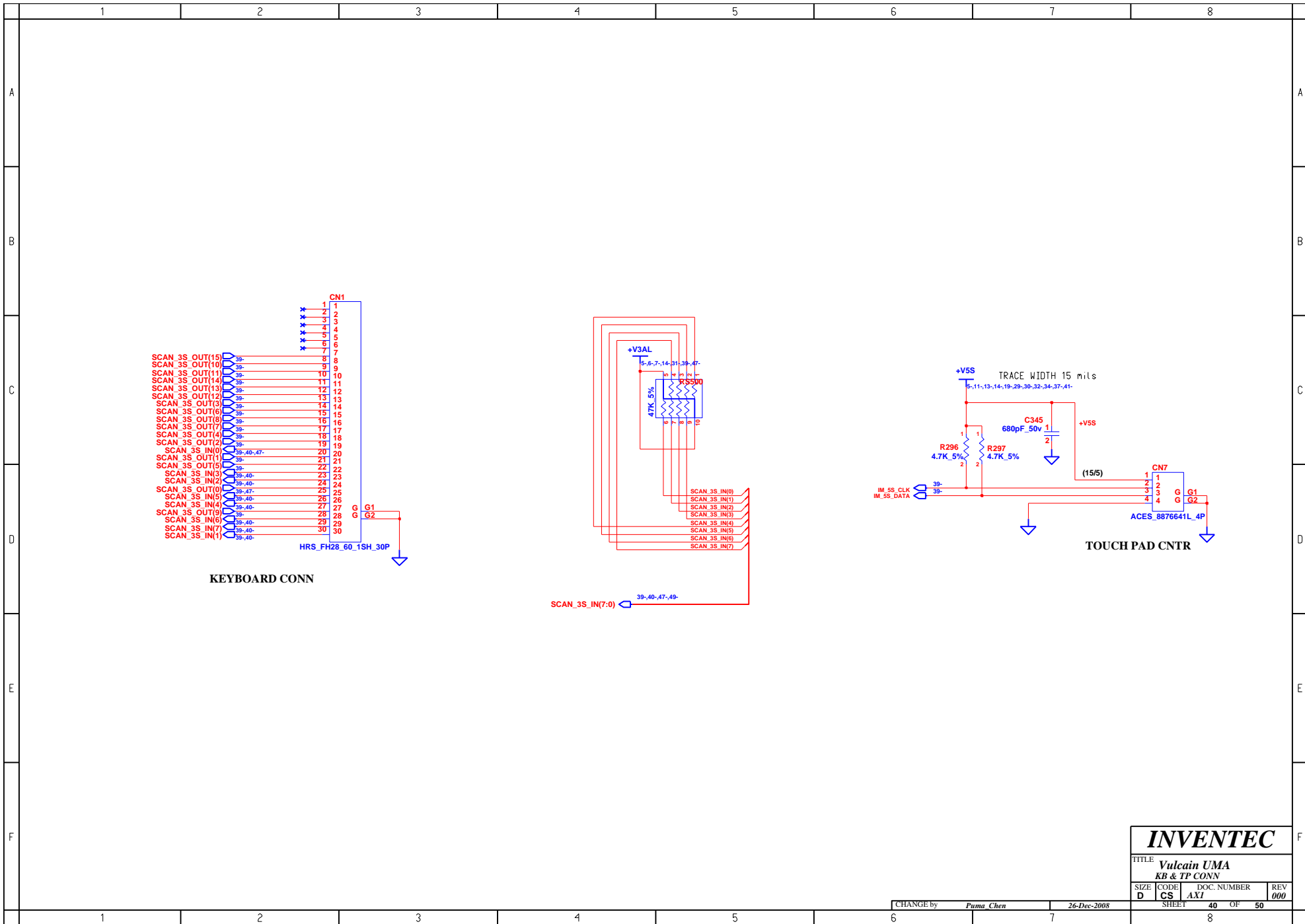

INVENTEC			
TITLE Vulcain UMA			
KB & TP CONN			
SIZE	CODE	DOC. NUMBER	REV
D	CS	AXI	000
CHANGE by <i>Puma Chen</i>		26-Dec-2008	
SHEET		40 OF	50
		8	

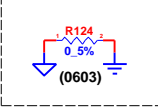
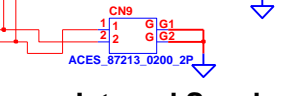
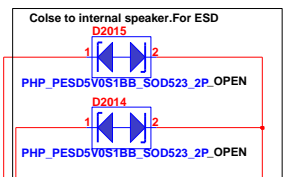
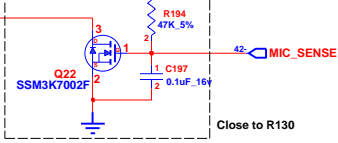
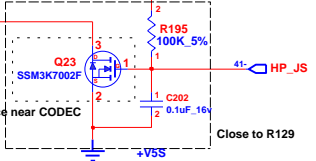
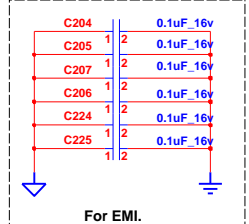
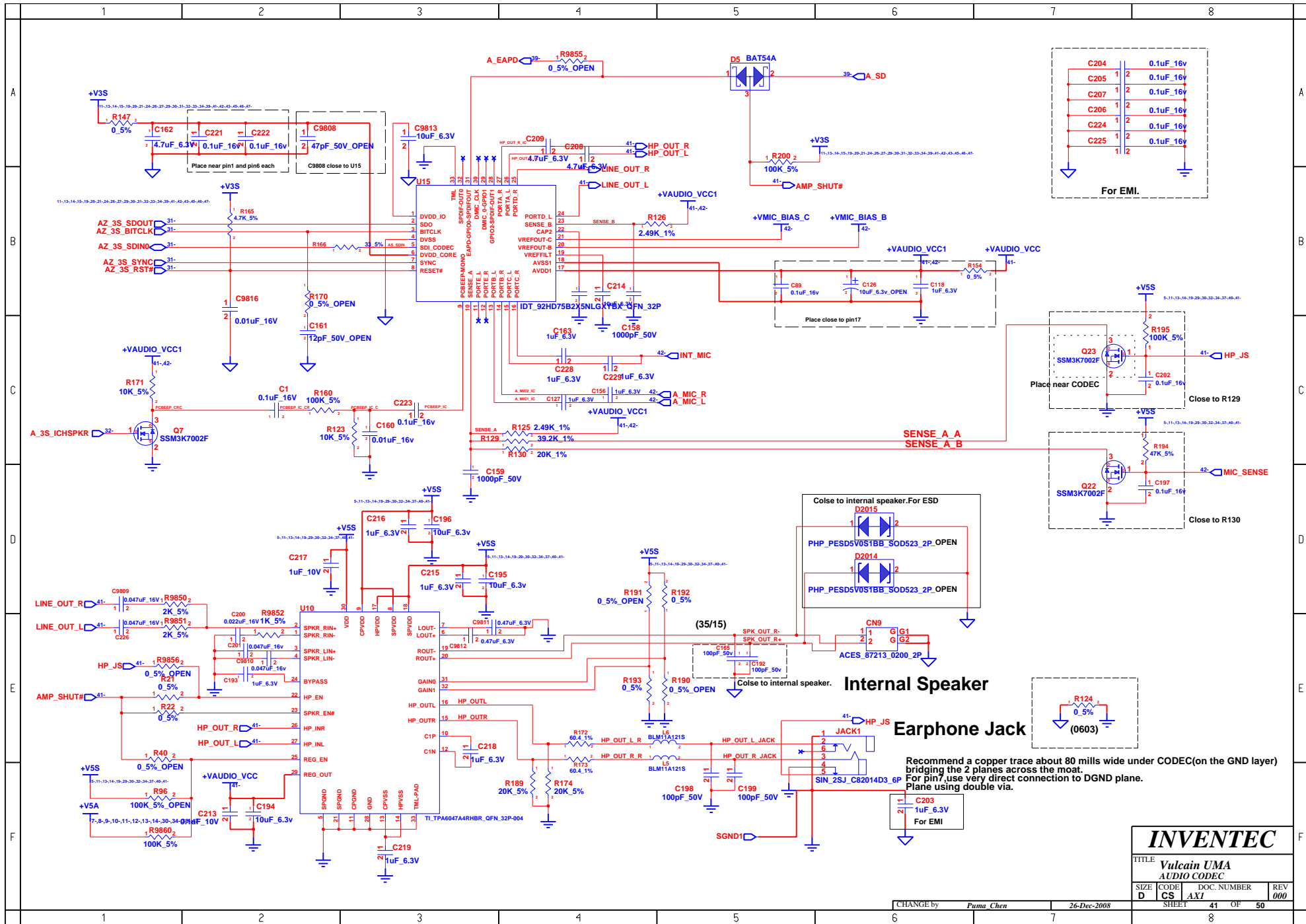

Recommend a copper trace about 80 mills wide under CODEC(on the GND layer) bridging the 2 planes across the moat.
For pin7, use very direct connection to DGND plane.
Plane using double via.

INVENTEC			
TITLE Vulcain UMA AUDIO CODEC			
SIZE D	CODE CS	DOC NUMBER AXI	REV 000
SHEET 41		OF 50	

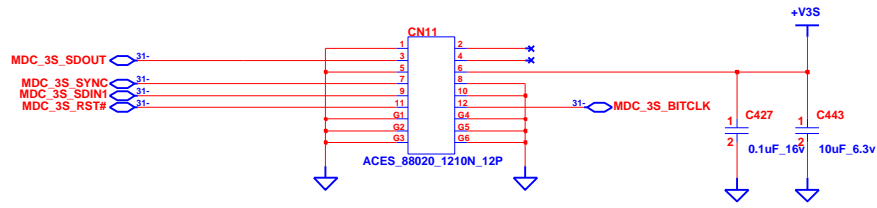
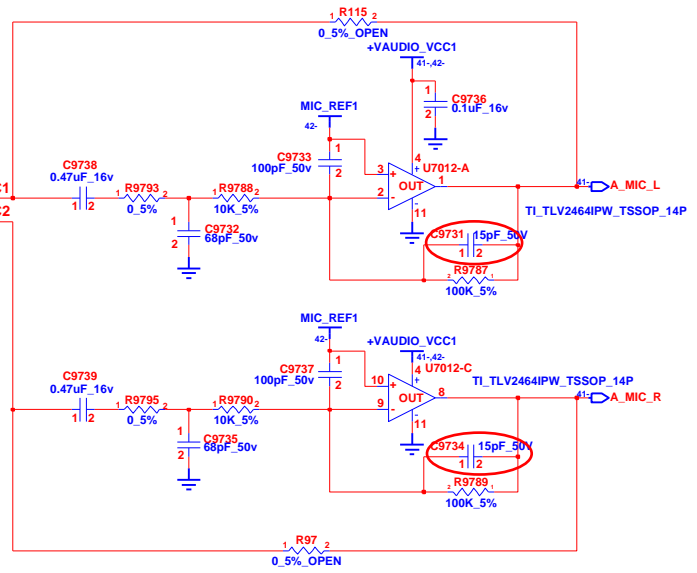
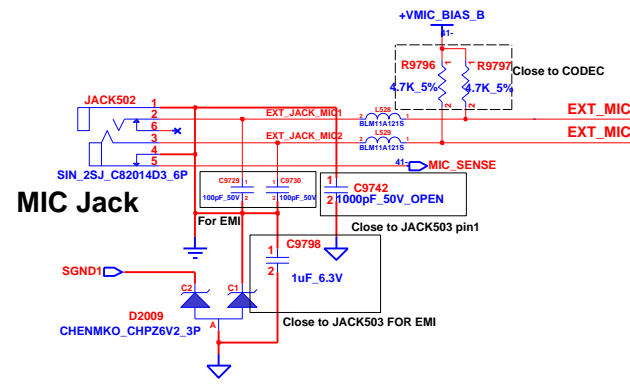
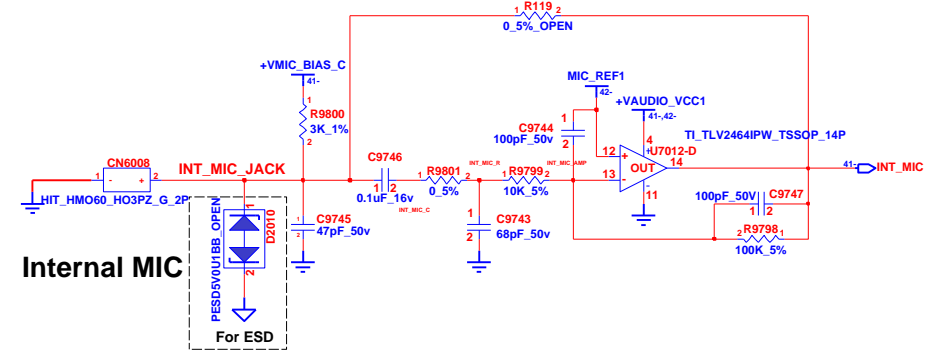
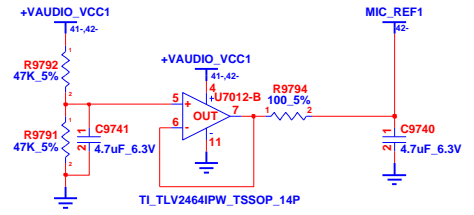

MDC CNTR

INVENTEC			
TITLE Vulcain UMA MDC CNTR			
SIZE D	CODE CS	DOC. NUMBER AXI	REV 000
CHANGE by <i>Puma Chen</i>		26-Dec-2008	
SHEET		42	OF 50

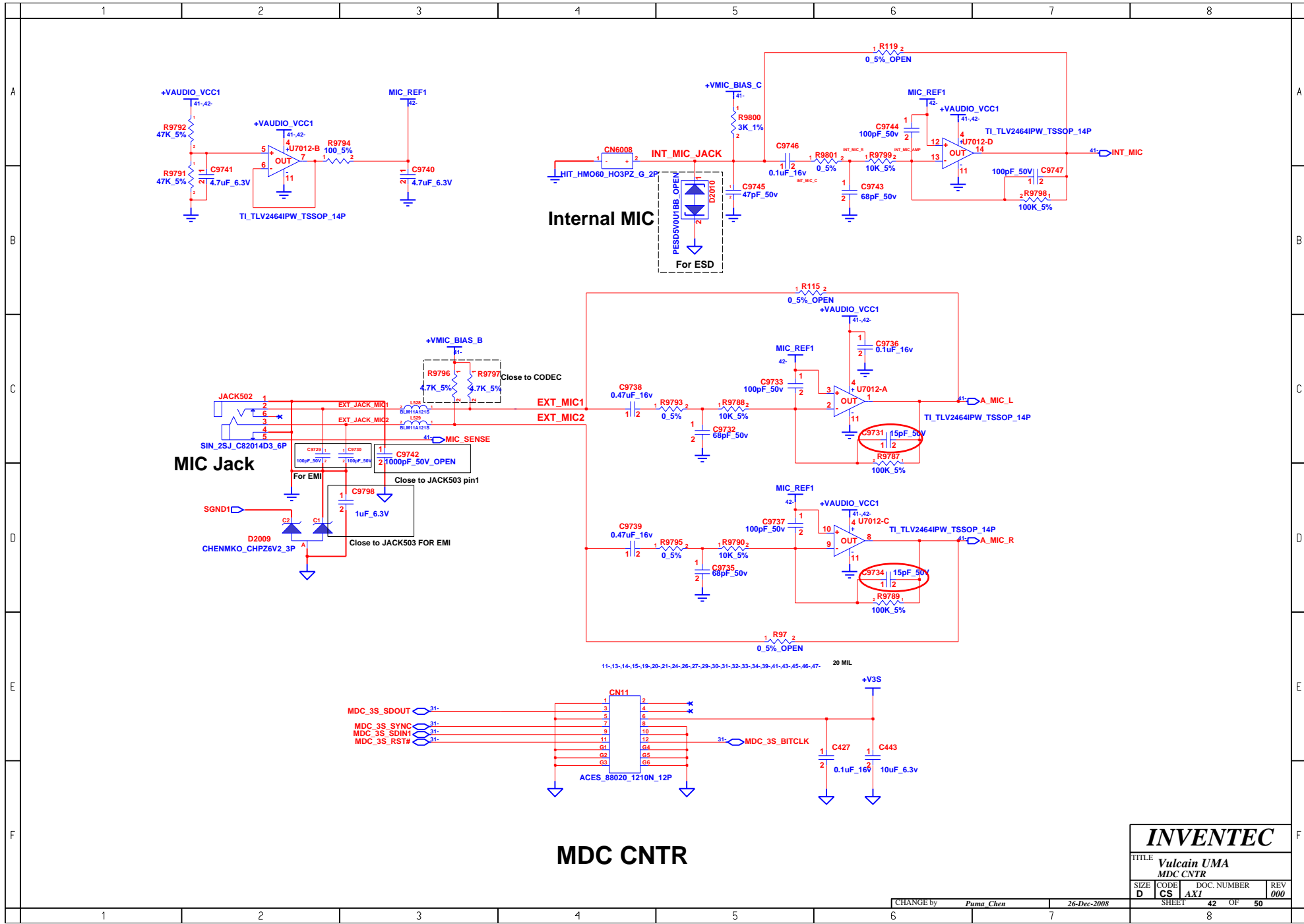

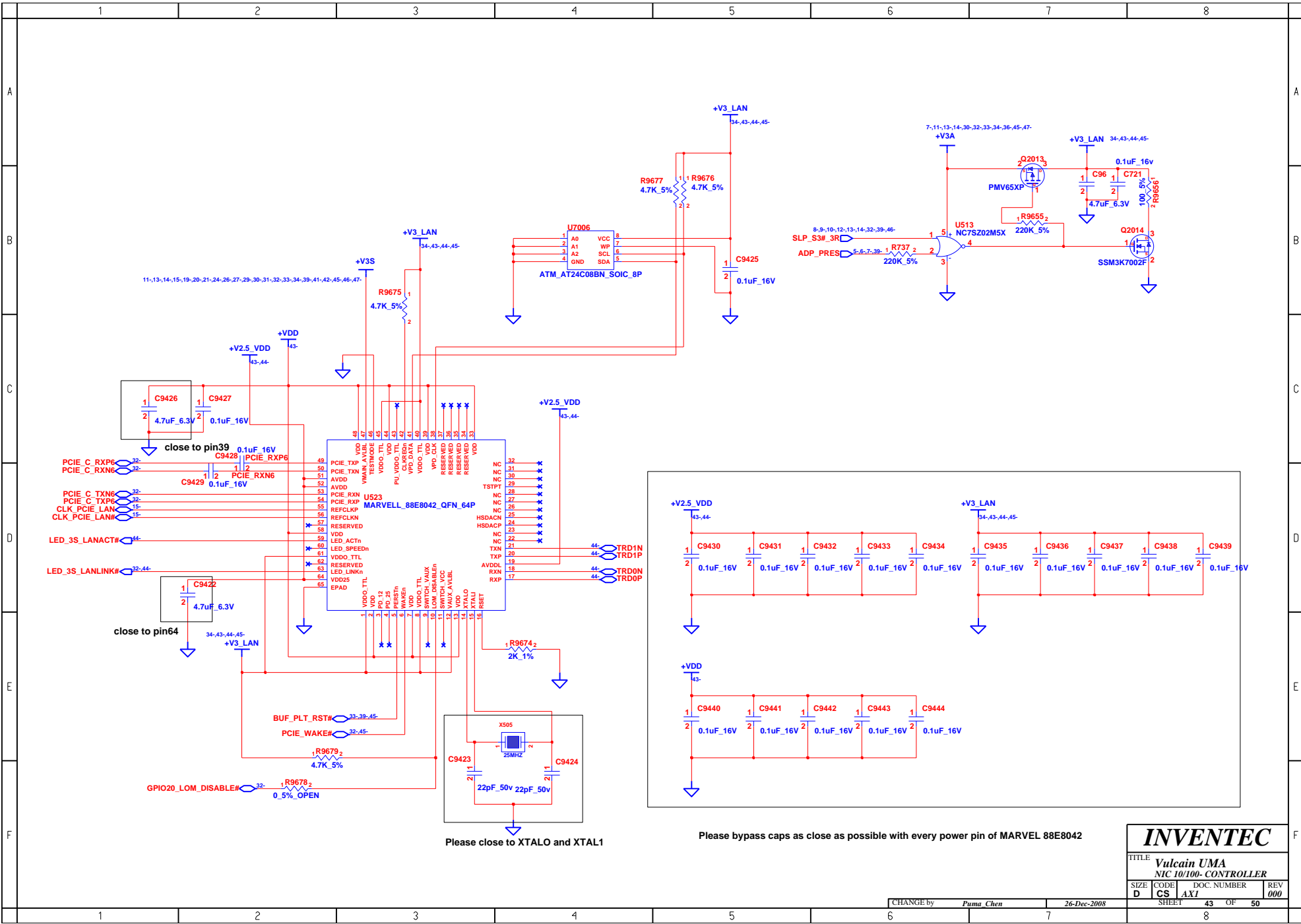

INVENTEC			
TITLE			
Vulcain UMA NIC 10/100- CONTROLLER			
SIZE	CODE	DOC. NUMBER	REV
D	CS	AXI	000
CHANGE by		Puma Chen	26-Dec-2008
SHEET		43	OF 50

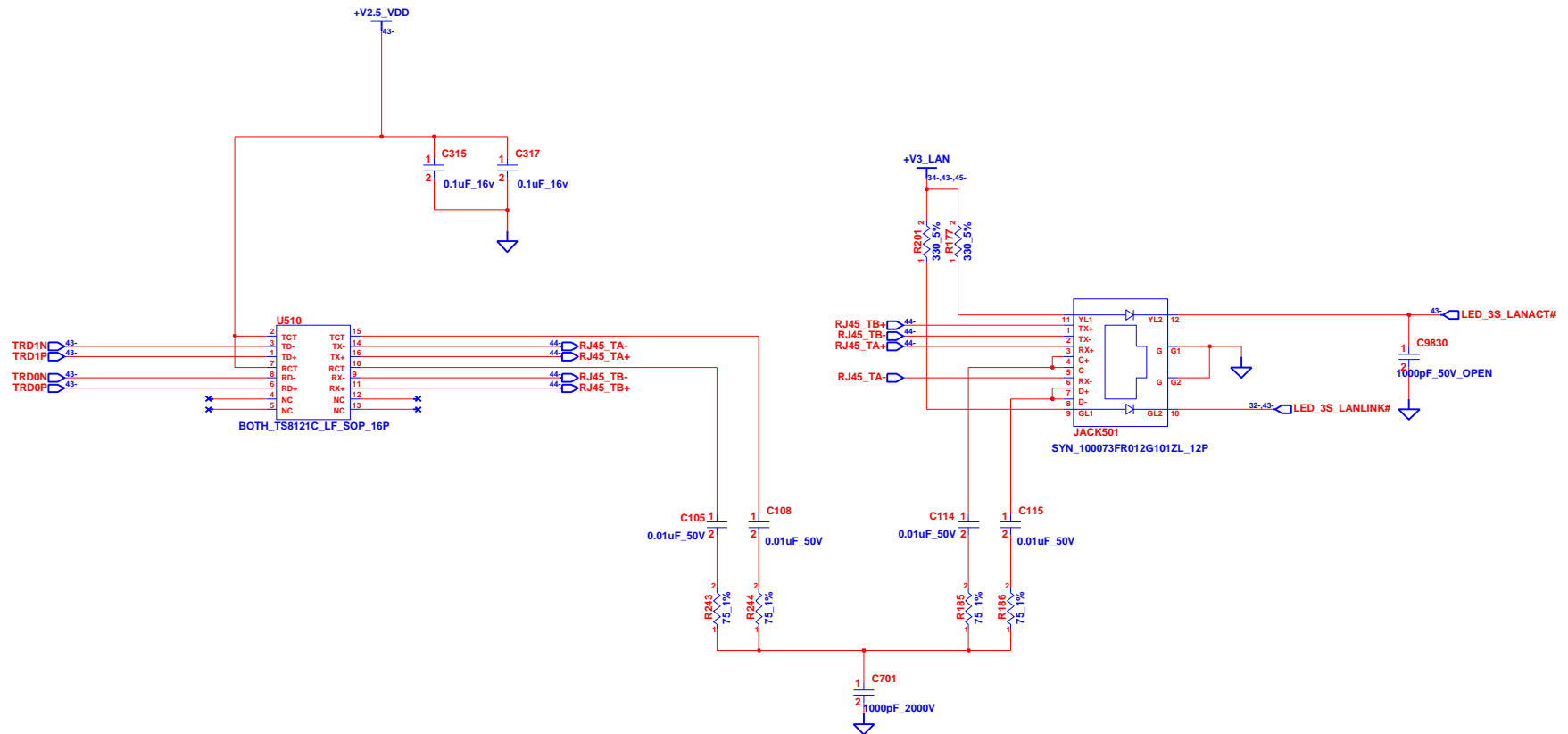

INVENTEC

TITLE			
Vulcan UMA			
NIC 10/100 - RJ45			
SIZE	CODE	DOC. NUMBER	REV
D	CS	AXI	000

CHANGE by Puma Chen 31-Mar-2009

SHEET 44 OF 50

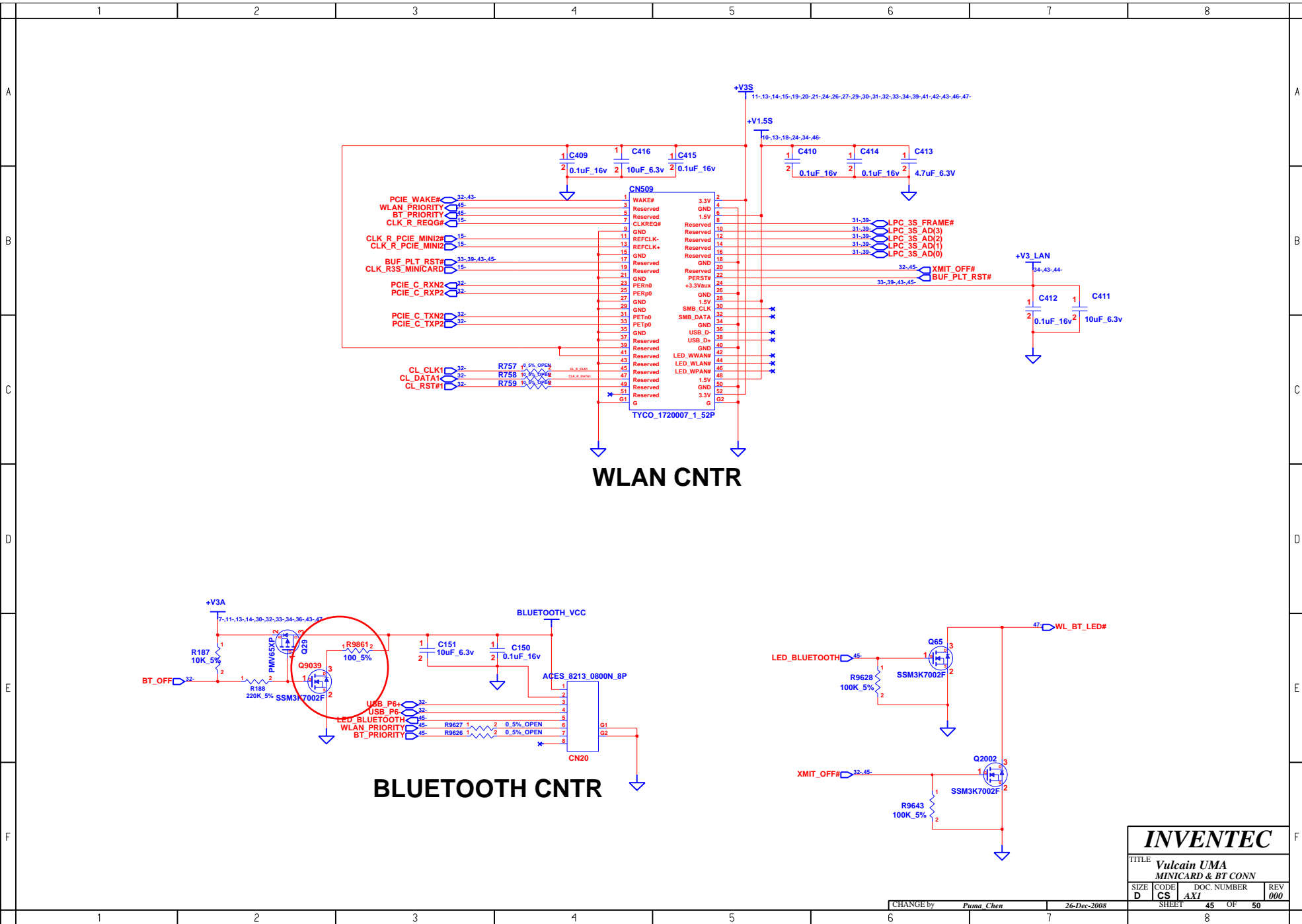

WLAN CNTR

BLUETOOTH CNTR

INVENTEC			
TITLE Vulcain UMA MINICARD & BT CONN			
SIZE D	CODE CS	DOC. NUMBER AX1	REV 000

CHANGE by *Puma Chen* 26-Dec-2008

SHEET 45 OF 50

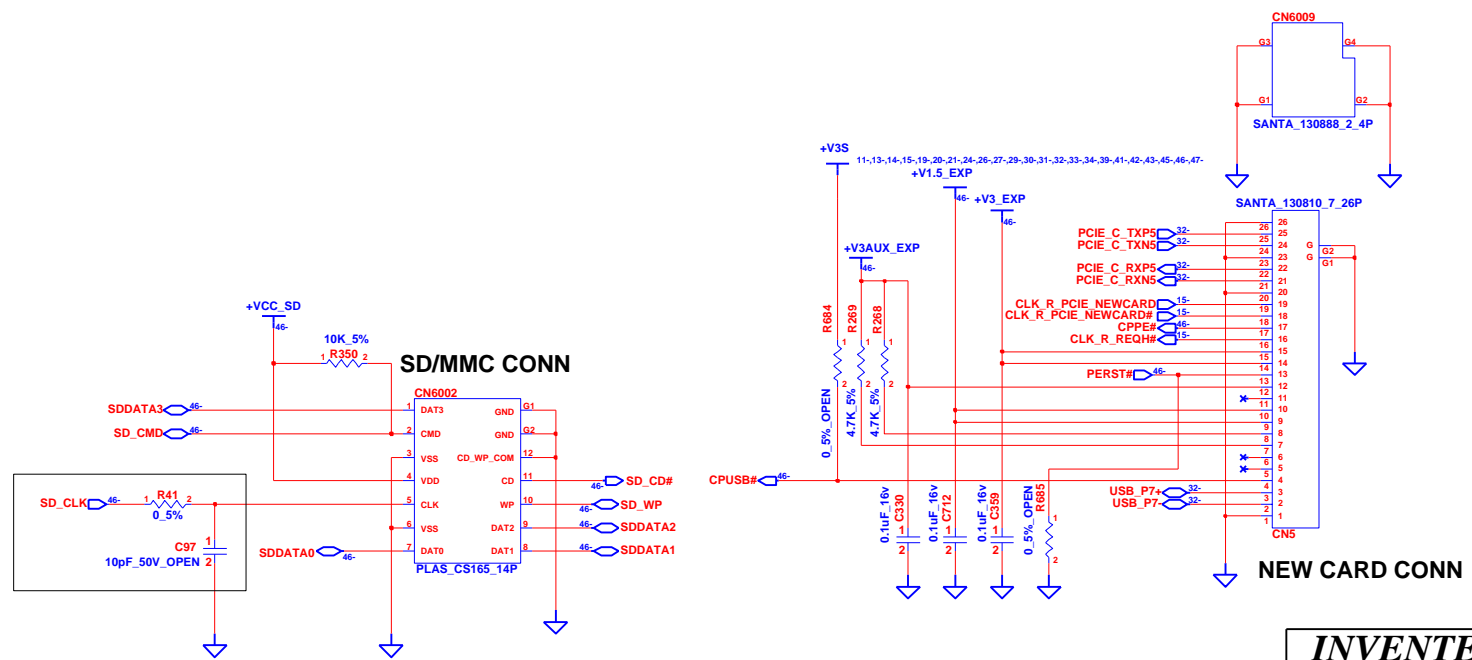
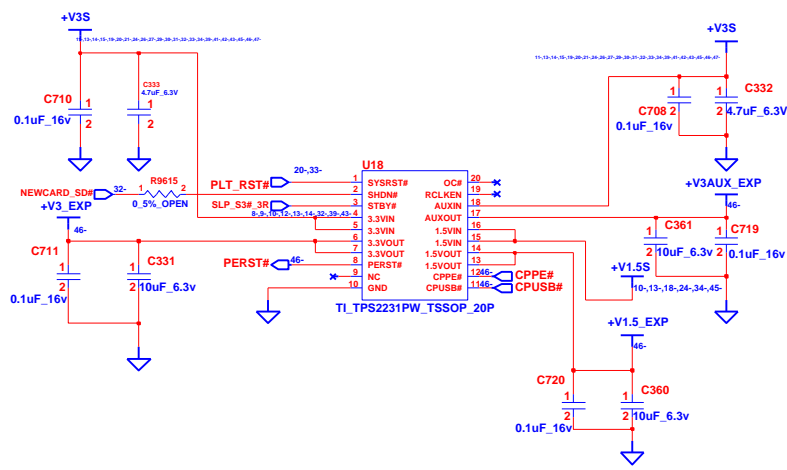
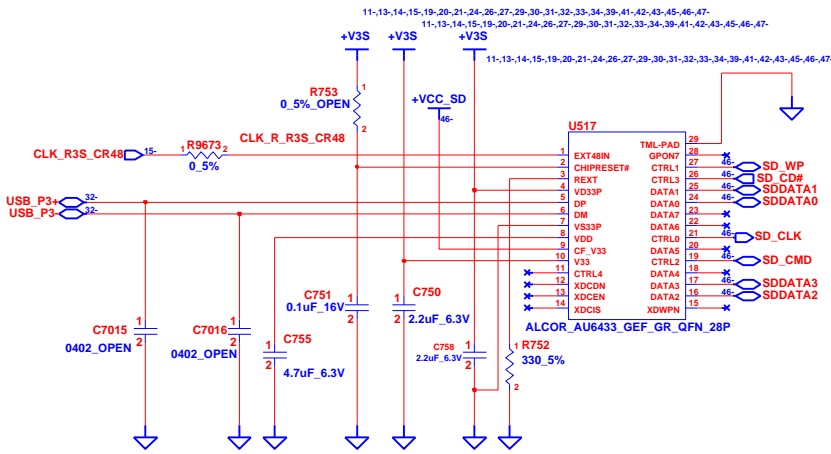

INVENTEC			
TITLE Vulcain UMA NEW CARD & SD/MMC			
SIZE D	CODE CS	DOC. NUMBER AX1	REV 000
CHANGE by <i>Puma Chen</i>		12-Feb-2009	
SHEET		46	OF 50

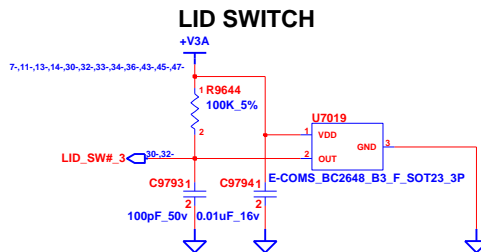
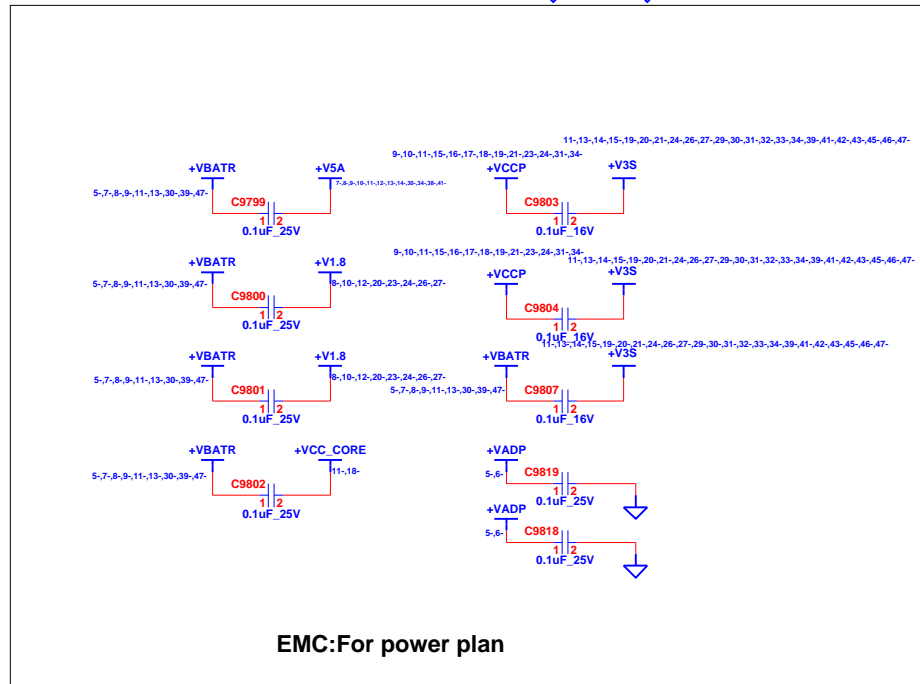
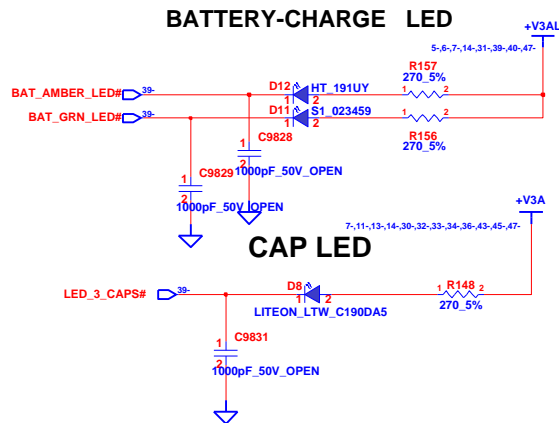
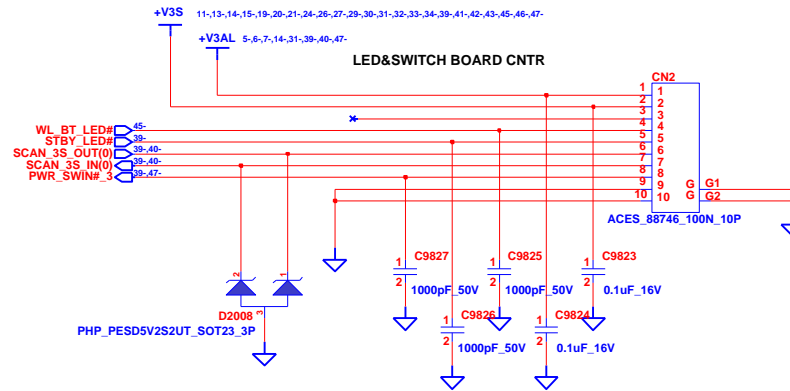
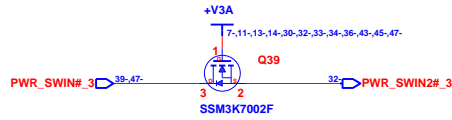

INVENTEC

TITLE			
Vulcain UMA			
BUTTON & LED			
SIZE	CODE	DOC. NUMBER	REV
D	CS	AXI	000

CHANGE by Puma Chen 24-Feb-2009

SHEET 47 OF 50

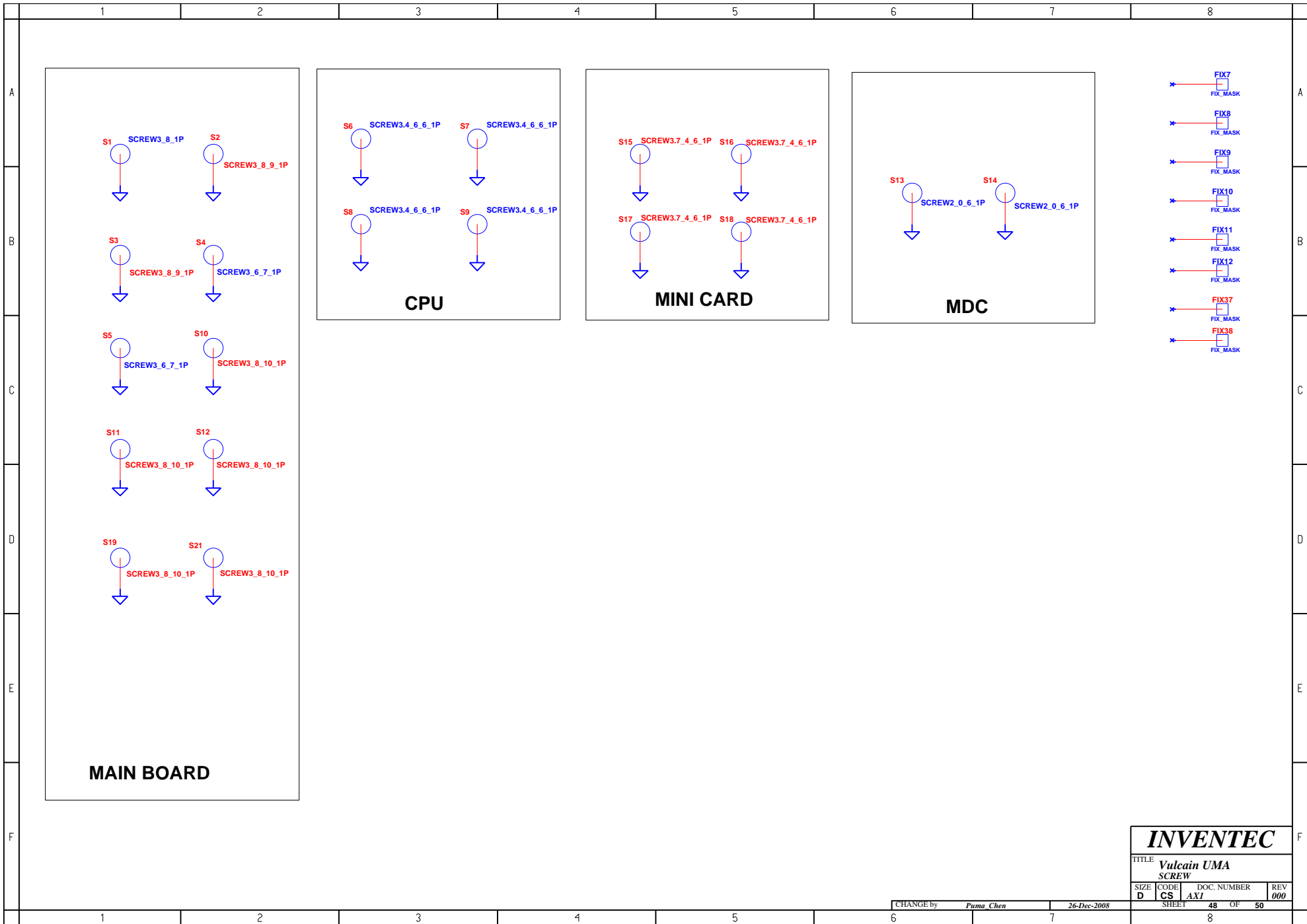

INVENTEC

TITLE			
Vulcain UMA			
SCREW			
SIZE	CODE	DOC. NUMBER	REV
D	CS	AXI	000
CHANGE by		SHEET	
Puma Chen		48 OF 50	
26-Dec-2008		8	

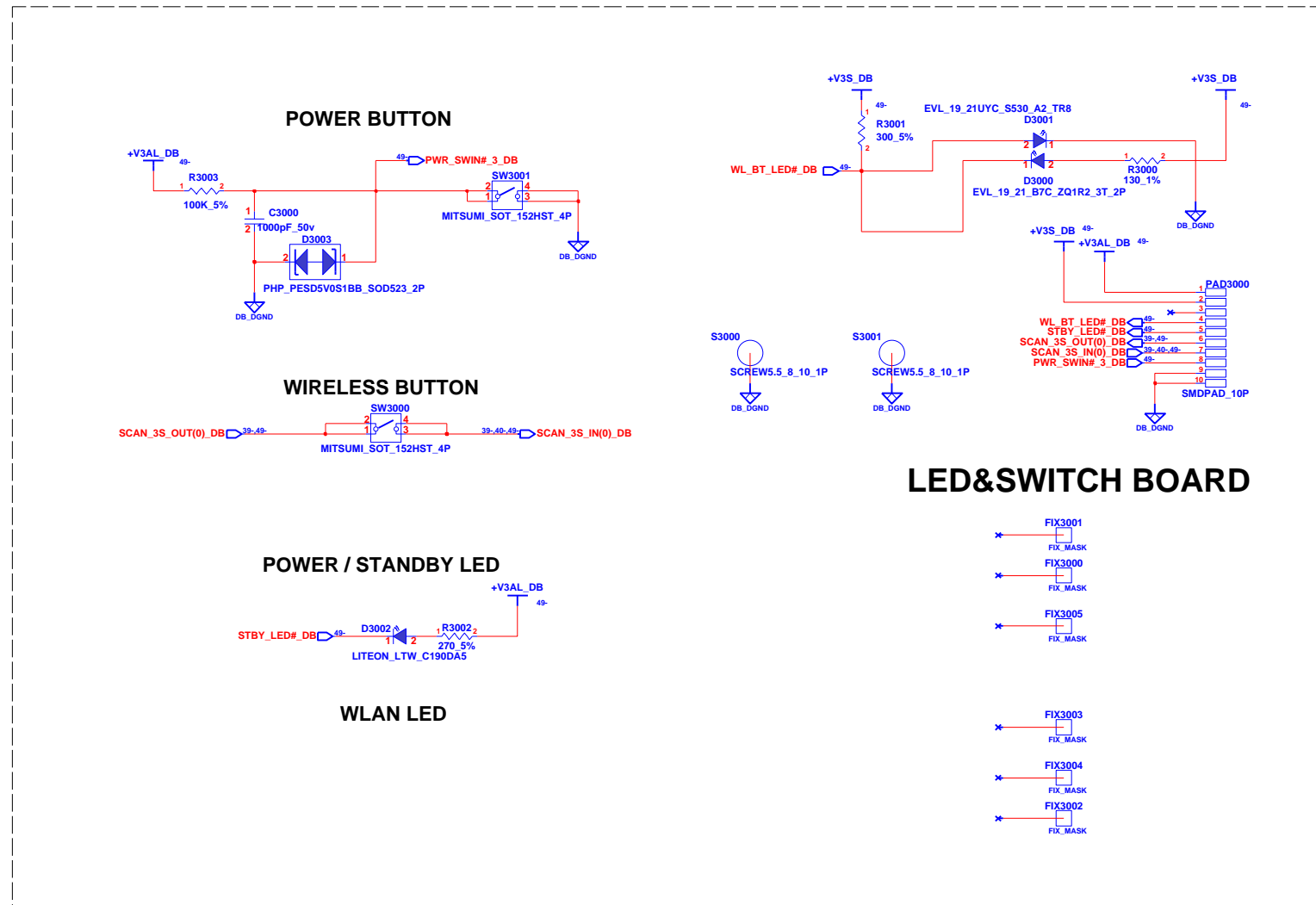

SWITCH DAUGHTER BOARD

INVENTEC			
TITLE Vulcain UMA SWITCH Board			
SIZE D	CODE CS	DOC. NUMBER 1310A22597-0-MTR	REV 000
CHANGE by <i>Puma Chen</i>		26-Dec-2008	
SHEET		49	OF 50

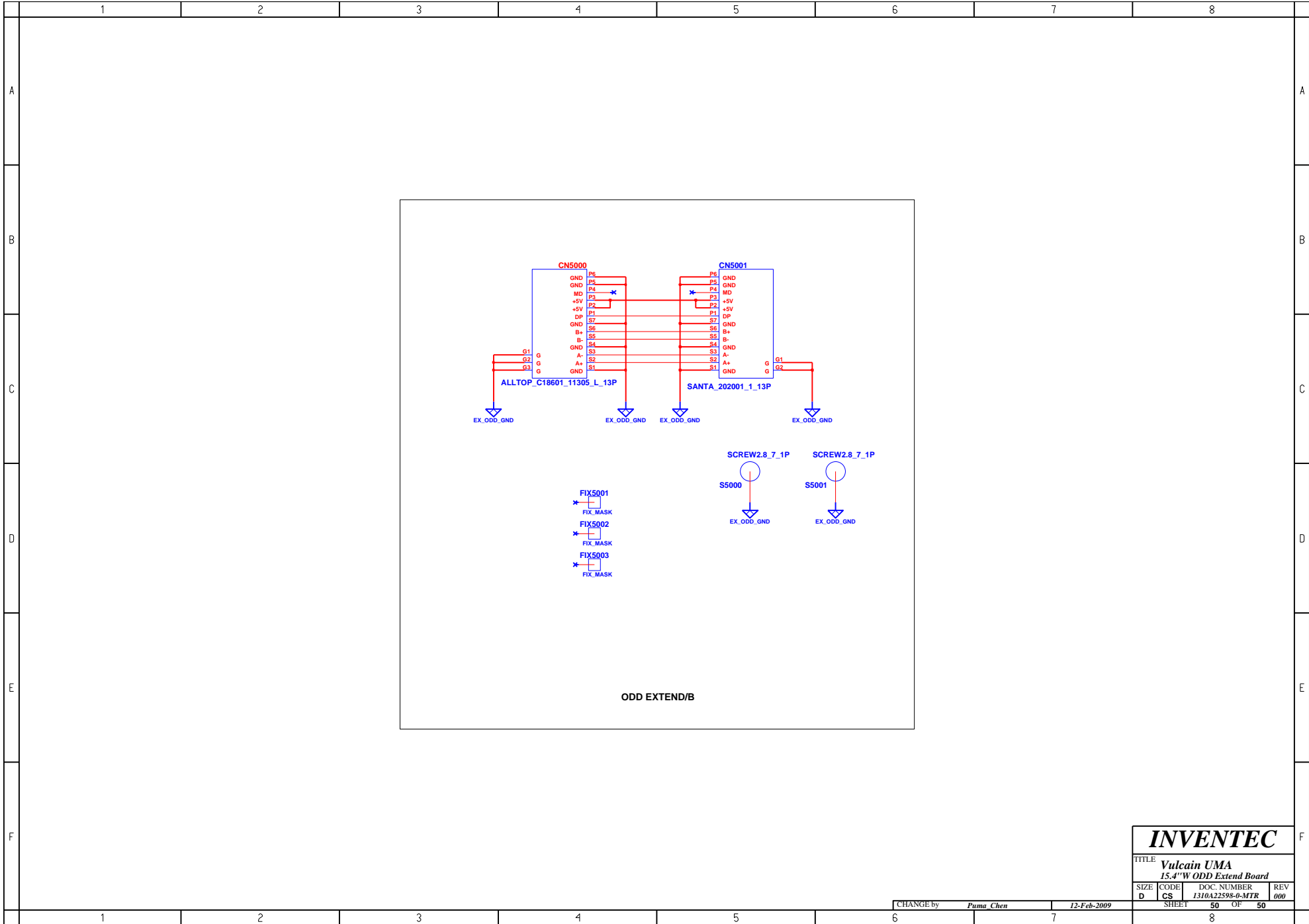

INVENTEC

TITLE **Vulcain UMA**
15.4" W ODD Extend Board

SIZE	CODE	DOC. NUMBER	REV
D	CS	1310a22598-0-MTR	000

CHANGE by *Puma Chen* 12-Feb-2009

SHEET 50 OF 50